

website : <http://www.LGService.com>
e-mail : <http://LGService.com/techsup.html>

WASHING MACHINE SERVICE MANUAL

CAUTION

READ THIS MANUAL CAREFULLY TO DIAGNOSE TROUBLE
CORRECTLY BEFORE OFFERING SERVICE.

MODEL : WD-1015(0~9)S(U)P WD-9015(0~9)S(U)P
 WD-8015(0~9)S(U)P WD-6515(0~9)S(U)P
 WD-1015(0~9)N(U)P WD-9015(0~9)N(U)P
 WD-8015(0~9)N(U)P WD-6515(0~9)N(U)P



LG Electronics Inc.

CONTENTS

1. SPECIFICATION.....	3
2. FEATURES & TECHNICAL EXPLANATION	4
3. PARTS IDENTIFICATION	6
4. INSTALLATION.....	7
5. OPERATION.....	10
6. WIRING DIAGRAM / PROGRAM CHART	12
7. TROUBLESHOOTING.....	13
7-1.BEFORE PERFORMING SERVICE	13
7-2.TEST MODE	13
7-3.HOW TO KNOW THE WATER LEVEL FREQUENCY.....	13
7-4.ERROR DISPLAY	14
8. ERROR DIAGNOSIS AND CHECK LIST	16
8-1. DIAGNOSIS AND ANSWER FOR ABNORMAL OPERATION	16
8-2. FAULT DIAGNOSIS AND TROUBLESHOOTING	19
9. DISASSEMBLY INSTRUCTIONS	25
10. EXPLODED VIEW	32
10-1. THE EXPLODED VIEW OF CABINET ASSEMBLY	32
10-2. THE EXPLODED VIEW OF CONTROL PANEL & DISPENSER ASSEMBLY.....	33
10-3. THE EXPLODED VIEW OF DRUM & TUB ASSEMBLY.....	34
* APPENDIX (Replacement parts list).....	35

1. SPECIFICATION

ITEM		WD-1015(0~9)S(U)P WD-8015(0~9)S(U)P	WD-1015(0~9)N(U)P WD-8015(0~9)N(U)P	WD-8015(0~9)T(U)P WD-6515(0~9)T(U)P	WD-1015(0~9)T(U)P WD-9015(0~9)T(U)P
POWER SUPPLY		220-240V~, 50Hz			
PRODUCT WEIGHT		50kg	55kg	65kg	
ELECTRICITY CONSUMPTION	WASHING	190W			
	SPIN (800rpm)	300W			
	DRAIN MOTOR	32W			
	WASH HEATER	1900W		2000W	2100W
REVOLUTION SPEED	WASH	50rpm			
	SPIN	WD-6515(0~9)S(N)(T)(U)P	400 / 500 / 600 / 650rpm		
		WD-8015(0~9)S(N)(T)(U)P	400 / 500 / 600 / 800rpm		
		WD-9015(0~9)S(N)(T)(U)P	400 / 600 / 800 / 900rpm		
		WD-1015(0~9)S(N)(T)(U)P	400 / 600 / 800 / 1000rpm		
OPERATION WATER PRESSURE		0.3-10kgf / cm ² (30-1000kPa)			
CONTROL TYPE		Electronic			
WASH CAPACITY		Synthetic(1.5), Delicate(1.0) Wool(1.0), Hand Wash(1.0) Quick 30(1.0)	Synthetic(1.7), Delicate(1.5) Wool(1.5), Handwash(1.5) Quick 30(1.5)	Synthetic(2.0), Delicate(2.0) Wool(2.0), Handwash(2.0) Quick 30(2.0)	Synthetic(3.0), Delicate(2.0) Wool(2.0), Handwash(2.0) Quick 30(2.0)
DIMENSION [(W)mm X (D)mm X (H)mm]		600 X 360 X 850	600 X 440 X 850	600 X 550 X 850	600 X 550 X 850
WASH PROGRAM		Cotton, Synthetic, Delicate, Wool, Hand Wash, Quick 30, Rinse+Spin			
OPTION		Bio, Time Save, Rinse +, Pre-Wash, Crease Care, Rinse Hold			
DOOR SWITCH TYPE		Bi-Metal type			
WATER LEVEL		9 steps (by sensor)			
RESERVATION		From 3 hours to 19 hours			
SENSING OF THE LAUNDRY AMOUNT		Adopted			
FUZZY LOGIC		Adopted			
DISPLAY OF THE REMAINING TIME		Adopted			
ERROR DIAGNOSIS		10 items			
POWER AUTO OFF		Adopted			
CHILD LOCK		Adopted			
AUTO RESTART		Adopted			

2. FEATURES & TECHNICAL EXPLANATION

2-1.FEATURES



■ Protection against creases

With the alternate rotation of the drum, creasing in the laundry is minimized.

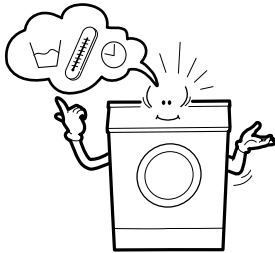

■ More economical by Fuzzy Logic System

FUZZY Logic System detects the amount of load and water temperature, and then determines the optimum water level and washing time to minimize energy and water consumption.

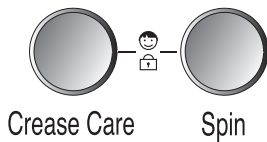

■ Child-Lock

The Child-Lock system has been developed to prevent children from pressing any button (except Power button) to change the programme during operation.

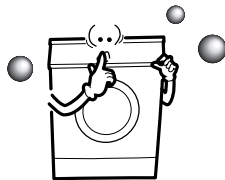

■ Low noise speed control system

By sensing the amount of load and balance, automatical distributes load evenly to minimize the spinning noise level.

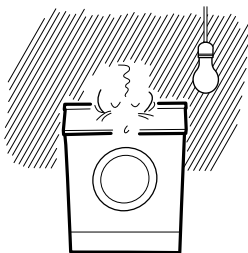

■ Auto Restart

Although the washing machine is turned off by a power failure, it restarts automatically where it stopped when power is supplied again. and it will be the same the machine is unplugged and is plugged in again.

2-2.DETERMINE WASHING TIME BY FUZZY LOGIC

To get the best washing performance optimal time is determined by sensing of water temperature, selected washing temperature and laundry amount.

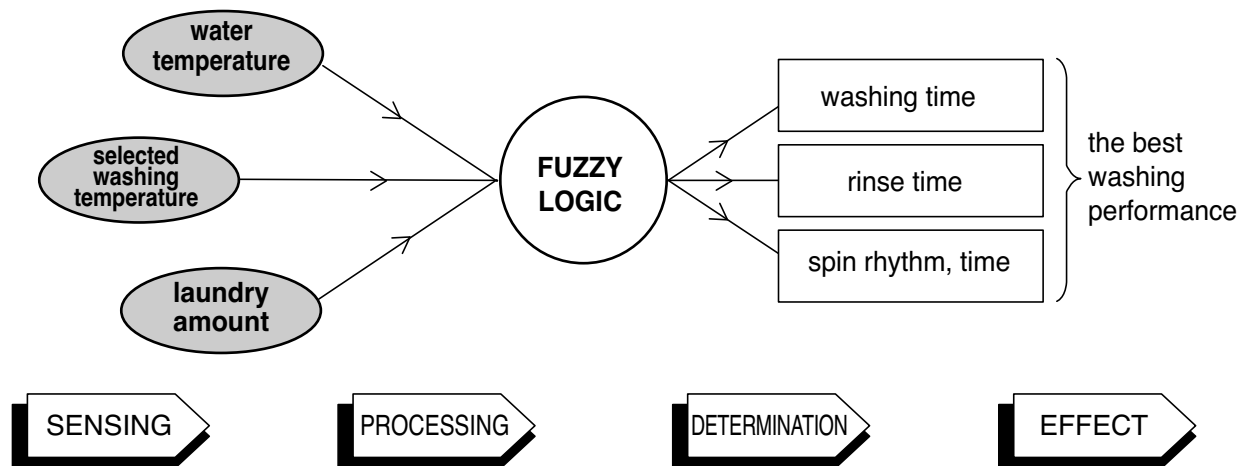

2-3.WATER LEVEL CONTROL

- This model adopts a pressure sensor which can sense the water level in the tub.
- When the water level reaches to the preset level the water supply is stopped, then the washing program proceeds.
- Spinning does not proceed until the water in the tub reduces a certain level.

2-4.THE DOOR CAN NOT BE OPENED

- While program is operating.
- While **Door Lock** light turns on.

3. PARTS IDENTIFICATION

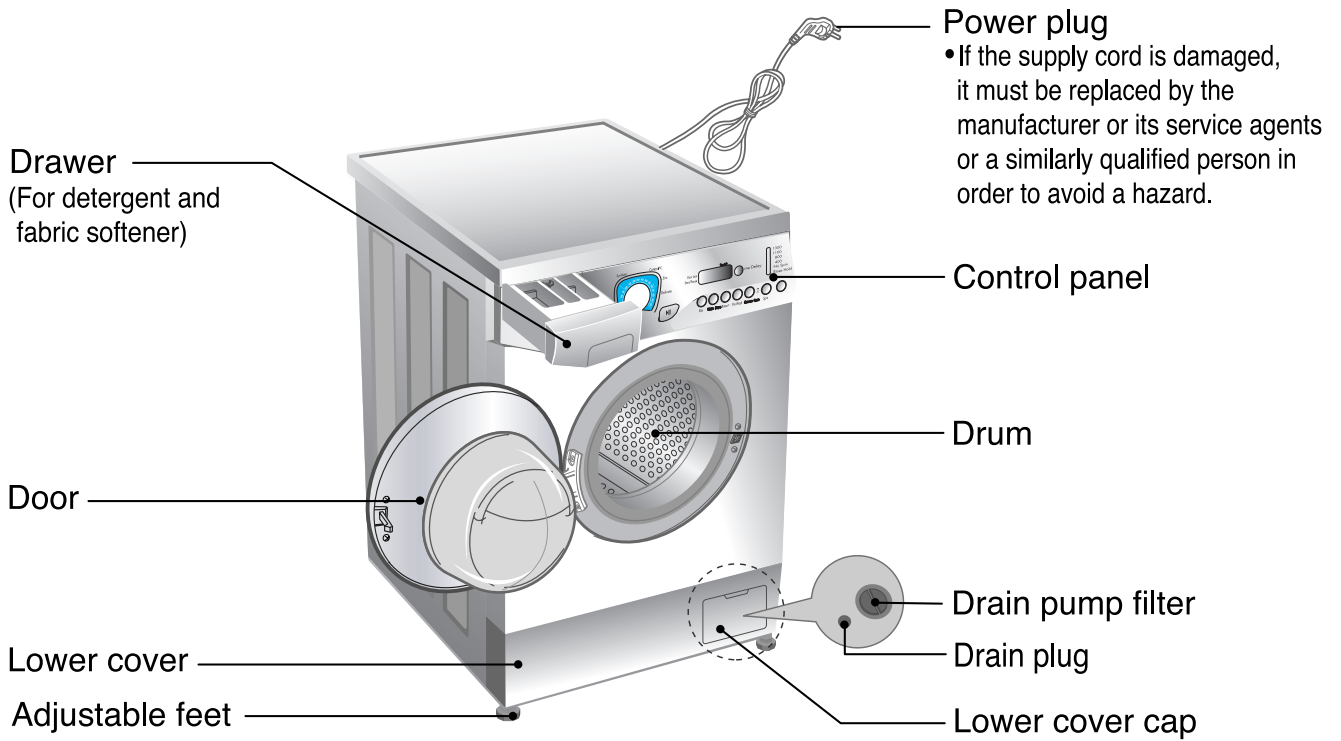

■ ACCESSORIES

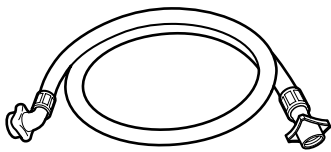

Hot/Cold (2EA)
Cold (1EA)

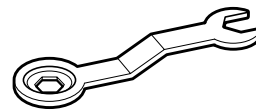

Wrench

4. INSTALLATION

- ① Before servicing ask the customer what the trouble is.
- ② Check the adjustment (power supply is 220-240V, remove the transit bolts....)
- ③ Check the troubles referring to the troubleshooting.
- ④ Decide service steps referring to disassembly instructions.
- ⑤ Then, service and repair.
- ⑥ After servicing, operate the appliance to see whether it works O·K or NOT.

■ STANDARD INSTALLATION

The appliance should be installed as follows.

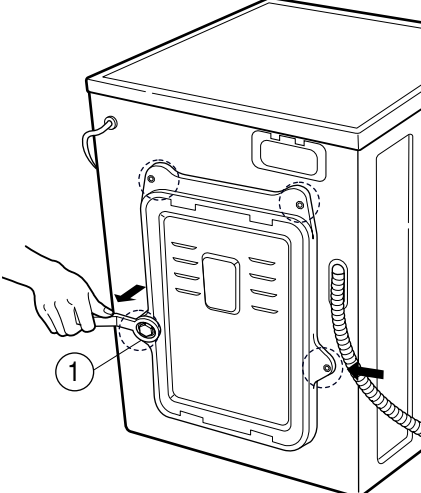
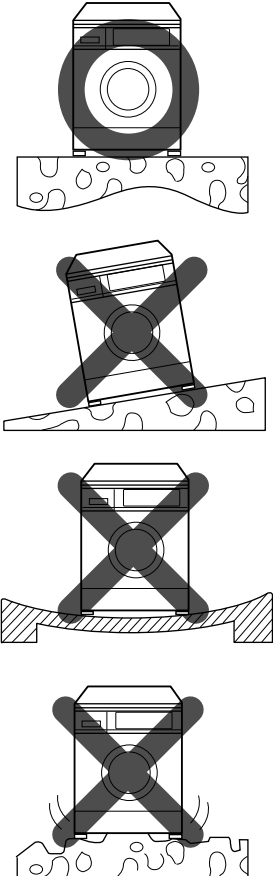
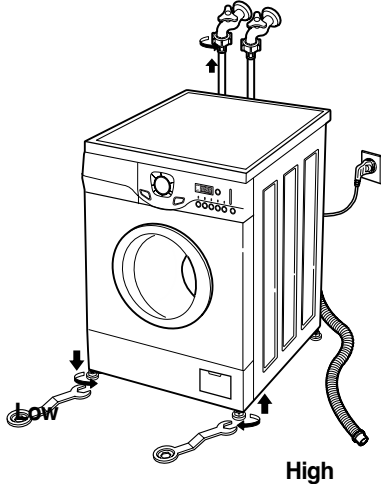
REMOVE THE TRANSIT BOLTS	INSTALL THE APPLIANCE ON FLAT AND FIRM SURFACE	ADJUST THE HORIZONTAL
<ul style="list-style-type: none"> • Remove the transit bolts (4EA:①) with supplied wrench. • Keep the transit bolts and wrench for future use. • Insert the 4 caps provided into the hole. 		<ul style="list-style-type: none"> • Turn the adjustable feet to set the appliance horizontally.  <ul style="list-style-type: none"> • The appliance goes up by rotating the feet clockwise. • The appliance comes down by rotating the feet counter-clockwise.

■ HOW TO CONNECT INLET HOSE

- Check that the rubber washer is inside of the valve connector.
- Connect the inlet hose firmly to prevent leak.

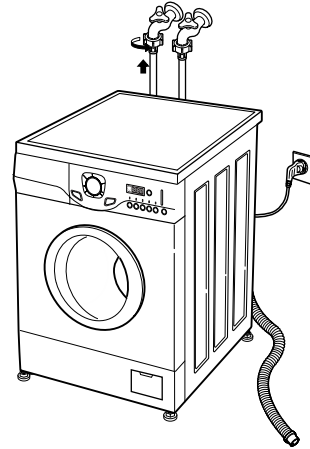

■ CONNECT DRAIN HOSE

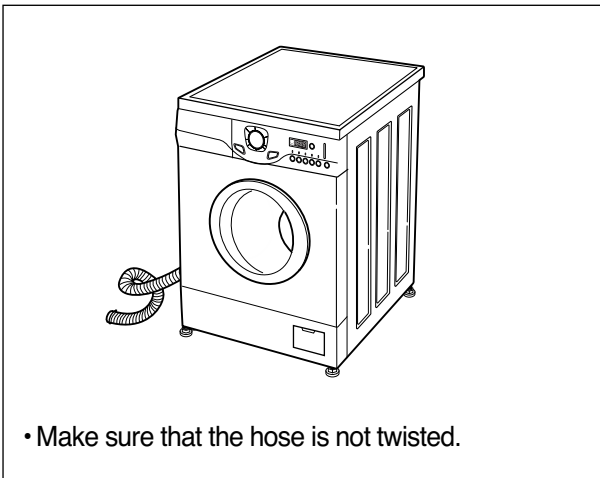

- Make sure that the hose is not twisted.

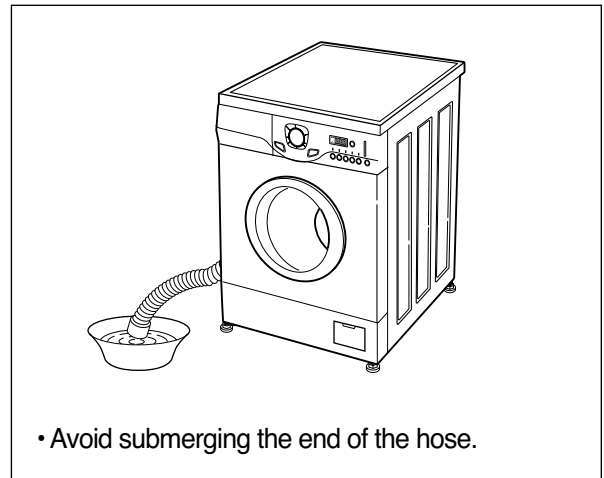

- Avoid submerging the end of the hose.

※ The drain hose should be placed under 100cm from the floor.

■ CONNECT POWER PLUG

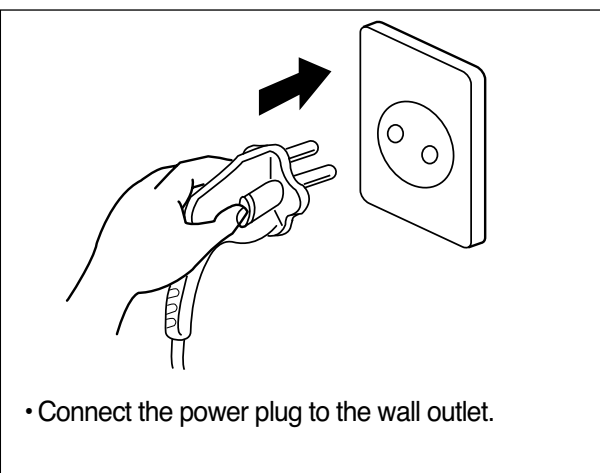

- Connect the power plug to the wall outlet.

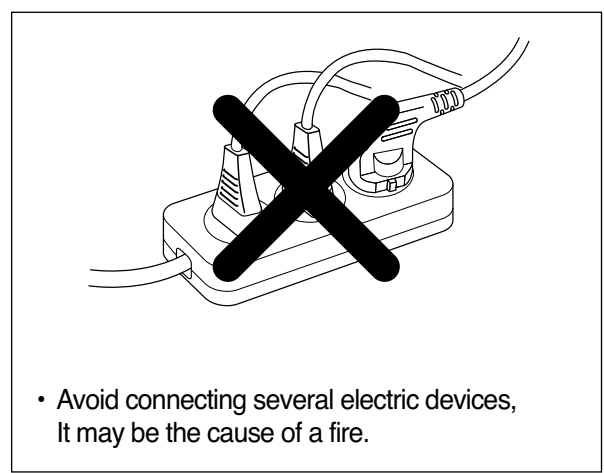

- Avoid connecting several electric devices, It may be the cause of a fire.

7 TEST OPERATION

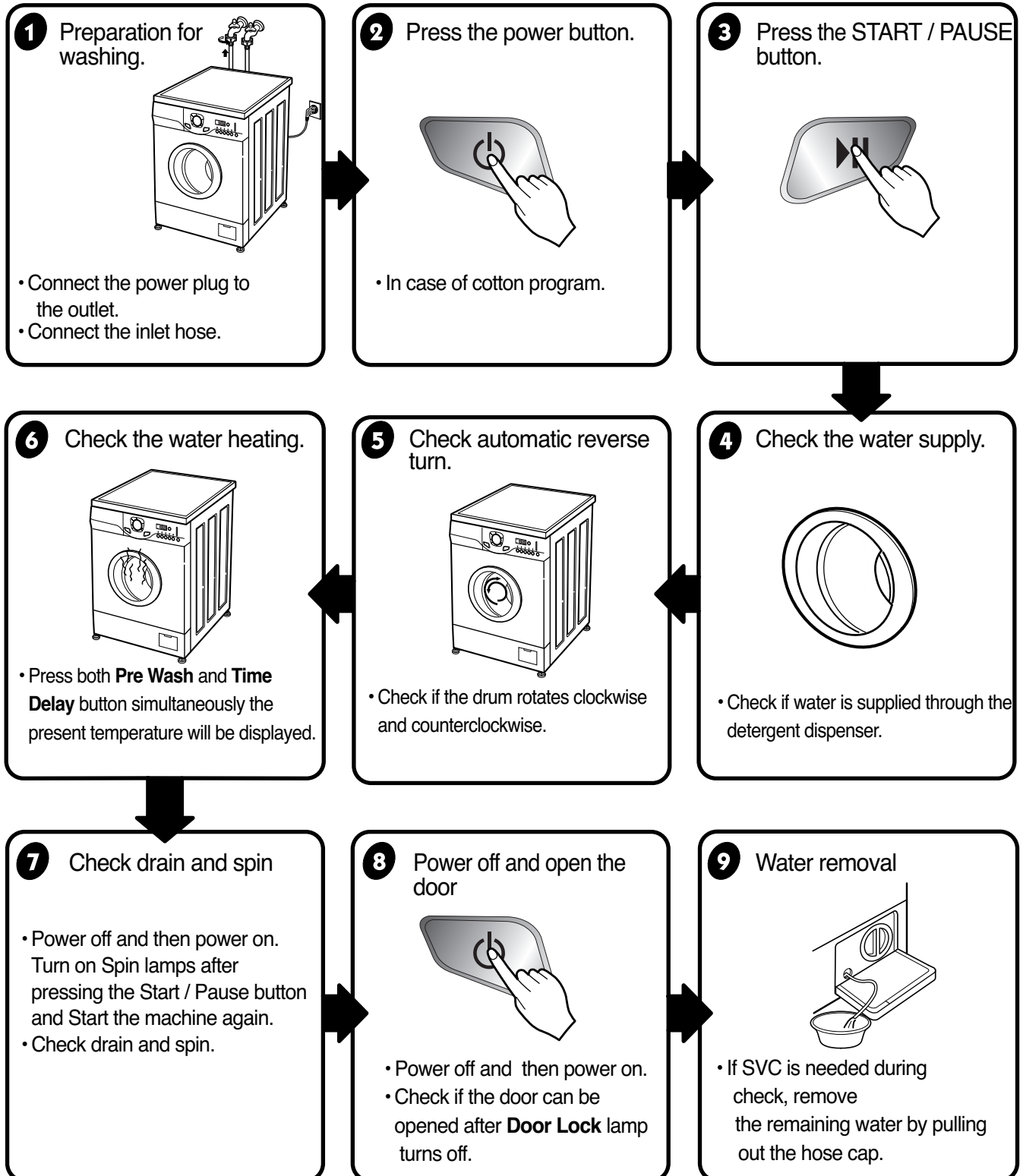

5. OPERATION

Eco

- It is possible in cotton course when 60°C

LED display

- Display the estimated remaining time (Hour : Minute) to finish.
- In case of abnormal operation, error indications are displayed. (IE, OE, UE, dE, tE, FE, PE)
- See troubleshooting guide.

Wash program selector

- 8 program can be set depending on the type of the laundry.
- If the power button is pressed, all lamps are on
- By turning the dial, [Cotton ⇄ Delicate ⇄ Quick 30 ⇄ Rinse + Spin ⇄ Spin ⇄ Hand Wash ⇄ Wool ⇄ Synthetic] can be selected. (The opposite is possible)

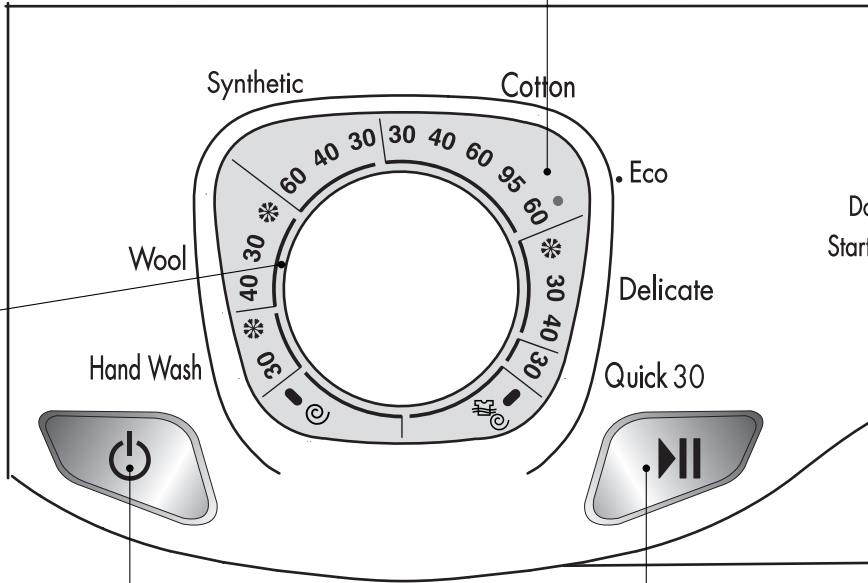

Power button

- Press the button to turn power on and off.
- Press the button to cancel the time delay.

Start / Pause button

- Use the button to start or pause wash cycle.
- The power turns off automatically 4 minutes after the pause button is pressed.

Option

- Bio** : • If you want to eliminate protein stains(milk, blood, chocolate...), you may select Bio by pressing the option button.[You can select Bio when temperature is higher than 60°C in Cotton and Synthetic.]
- Time Save** : • By selecting the Time Save option, the wash time may be reduced, depending on the program selected.
- Rinse+** : • If you wish to rinse more, the Rinse+ option will remove any trace of detergents.
- Pre Wash** : • If the laundry is heavily soiled, "Pre Wash" course is effective.
 - Pre Wash is available in Cotton and Synthetic Program.
- Crease Care** : • If you want to prevent crease, select this button with spin

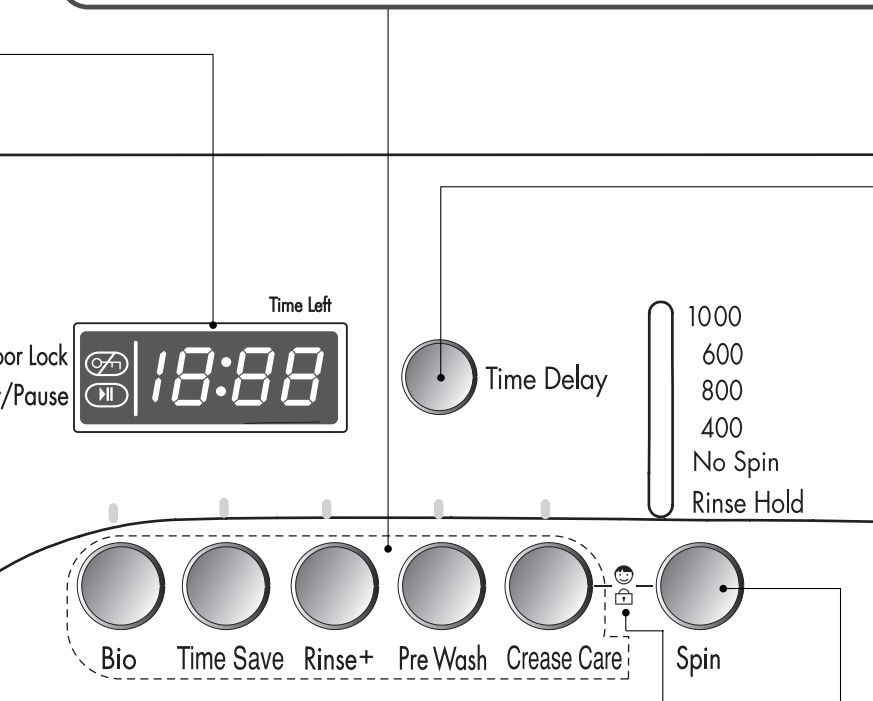

Time Delay

- Press the button when delayed washing is needed.
- When the button is pressed, [3:00] is displayed, maximum delay of [19:00] hours can be set.
- Each press advances time delay by the hour.
- Use [Power] button to cancel [Time Delay]
- [Time Delay] means the time required from the present to the completion of washing.

Child - Lock

- **Child Lock** system can be set and canceled by pressing and holding both [Spin] and [Crease Care] button simultaneously more than 2 seconds.
- Once **Child Lock** is set, all buttons are inoperable.
- **Child Lock** system can be set anytime even during Power-off and operation.
- It is automatically cancelled when an operational error occur.

Spin

- **WD-6515(0~9)S(N)(T)(U)P**
⇒ No spin / 400 / 500 / 600 / 650
- **WD-8015(0~9)S(N)(T)(U)P**
⇒ No spin / 400 / 500 / 600 / 800
- **WD-9015(0~9)S(N)(T)(U)P**
⇒ No spin / 400 / 600 / 800 / 900
- **WD-1015(0~9)S(N)(T)(U)P**
⇒ No spin / 400 / 600 / 800 / 1000

6. WIRING DIAGRAM / PROGRAM CHART

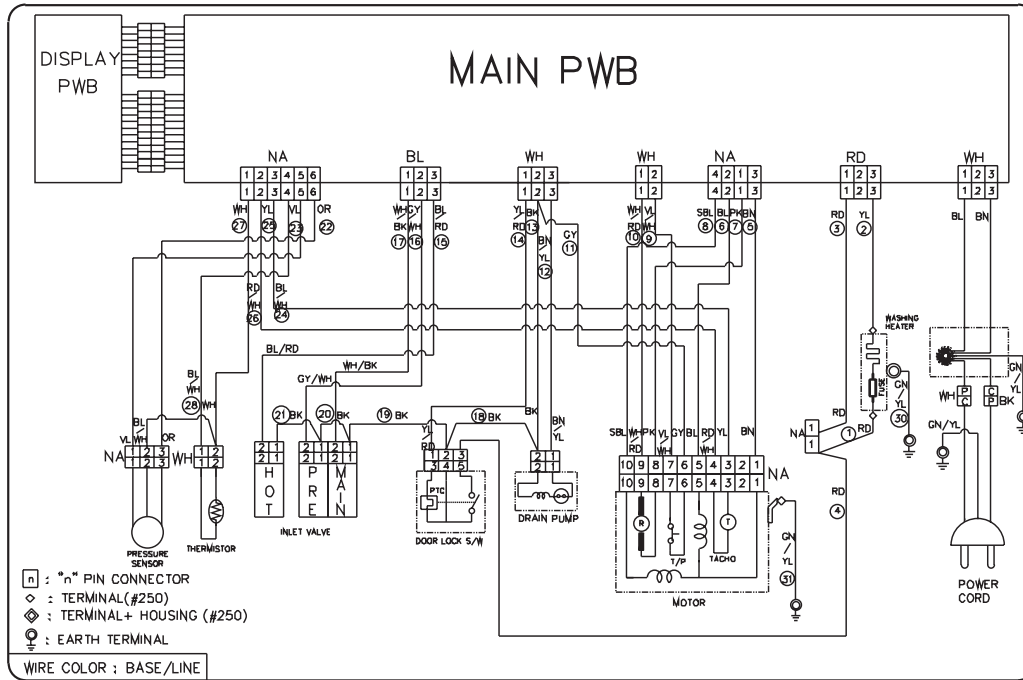

* Water Supply : W·S * Intermittent Spin : I·S * Disentangle : D·T

CYCLE COURSE	Washing				Rinse												Spin			A U T O F F	Normal Working Time (Hour:Minute)											
	Pre		Main		Normal				Rinse +				D·T	Spin	D·T																	
	W·S	Washing	Washing	Staycooling	1		2		3		4																					
	1	2	3	4	5	6	7	8	9	10	11	12	13	14	15	16	17	18	19			20	21	22	23	24	25	26	27	28	29	20
Time (SEC)				MIN				SEC				SEC				SEC																
Cotton	120	60	240	120	42																											2:35
Synthetic					87																										1:22	
Delicate					51																										1:03	
Wool					18																										58	
Hand Wash					4																										57	
Quick 30					24																										30	
Rinse + Spin					11																										20	
Spin																															12	

- * Basic Cycle
- * Optional Cycle
- * Pre-Setting Time : Water Supply - 120 sec.
Drain - 60 sec.
- * ~ Time for varies as the temperature or the amount of laundry
- * Basic time is minute in washing chart
- * The actual program time can be varied with the load amount, water temperature or ambient temperature

- * Pre Wash : If the laundry is heavily soiled, "Pre Wash" course is effective. Pre Wash is available in Cotton and Synthetic Program.
- * Eco : By selecting Eco function, the water temperature is reduced and washing time is lengthened. So you can economize in your consumption of energy.
- * Rinse+ : If you wish to rinse more, the Rinse+ function will remove any trace of detergents.
- * Bio : If you want to eliminate protein stains (milk, blood, chocolate...), you may select Bio function by pressing the option button.
- * Quick 30 : By selecting this function, you may wash a small quantity of colored laundry which is lightly soiled fast.
- * You can select Bio function and Eco function when temperature is higher than 60°C in Cotton and Synthetic. If the function is selected, the beginning water temperature can not be changed.

7. TROUBLESHOOTING

7-1. BEFORE PERFORMING SERVICE

- Be careful of electric shock or disconnecting the parts while trouble shooting.
- Voltage of each terminal in 220-240V and DC while applying an electric current.

7-2. QC TEST MODE.

- ① Pressing **Pre Wash** and **Crease Care** button simultaneously.
- ② Power button ON with pressing upper two button. then buzzer sound twice.
- ③ Press the START / PAUSE button as follows.

[Press the START / PAUSE button more 4 times until stop spinning]

Pressing number of [START / PAUSE] button	Checking Point	Display Status
None	All lamps turn on	
1 time	Clockwise spin (lef)	Motor rpm (About 50)
2 times	Low speed Spin	Motor rpm (About 63~67)
3 times	High speed Spin	Motor rpm (About 79~85) : WD-6515(0~9)T(U)P WD-8015(0~9)S(N)(T)(U)P
		Motor rpm (About 95~106) : WD-9015(0~9)T(U)P WD-1015(0~9)S(N)(T)(U)P
4 times	Inlet valve for pre-wash operation	Water level frequency (225~265)
5 times	Inlet valve for main-wash operation	Water level frequency (225~265)
	Hot inlet valve in case of hot water fill	
6 times	Inlet valve for main-wash operation	Water level frequency (225~265)
7 times	Counterclockwise spin (right)	Motor rpm (About 50)
8 times	A Heater is in operation for 3 sec.	Water Temperature
9 times	Draining pump operation	Water level frequency
10 times	Auto off operation	

7-3. HOW TO KNOW THE WATER LEVEL FREQUENCY

* Press the **Bio** and **Time delay** button simultaneously.

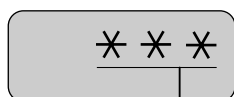







● The digits means water level frequency (10^{-1} kHz)

ex) 241 : Water level frequency = 241×10^{-1} kHz
= 24.1 kHz







7-4.ERROR DISPLAY.



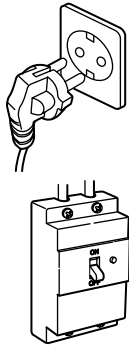

- If you press the [Start / Pause] button any error except PE will disappear and the machine will change into pause status.
- In case of 『 PE 』, 『 LE 』, 『 DE 』, if the error is not resolved within 15 sec. In case of other errors, if the error is not resolved within 4 min. Power will be turned off automatically and the error only will be blinked. But in the case of 『 FE 』, power will not be turned off.

	ERROR	SYMPTOM	CAUSE
1	WATER INLET ERROR		<ul style="list-style-type: none"> ○ Water has not reached to the pre-set level within 4 min. since inlet valve operated, or water has not reached to the normal level within 25 min.
2	IMBALANCE ERROR		<ul style="list-style-type: none"> ○ The appliance is tilted. ○ Laundry is gathered to one side. ○ Non distributable things are put into the drum.
3	DRAIN ERROR		<ul style="list-style-type: none"> ○ Water has not drained enough within 8 min.
4	OVERFLOW ERROR		<ul style="list-style-type: none"> ○ Water is automatically being pumped out because too much water is in the tub.
5	SENSOR PRESSURE S / W ERROR		<ul style="list-style-type: none"> ○ The sensor pressure switch is out of order.
6	DOOR OPEN ERROR		<ul style="list-style-type: none"> ○ The [Start / Pause] button is pressed with the door open. ○ The door switch is out of order.
7	HEATING ERROR		<ul style="list-style-type: none"> ○ The thermistor is out of order.

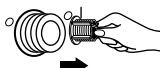
8. ERROR DIAGNOSIS AND CHECK LIST

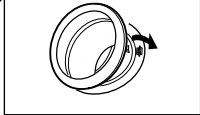
8-1. DIAGNOSIS AND ANSWER FOR ABNORMAL OPERATION

SYMPTOM	GUIDE FOR SERVICE CALL	
<p>NO POWER</p>	<p>Is the power plug connected firmly to 220-240V~ outlet?</p> <p style="text-align: center;">YES</p> <p>Power failure? or Breaker opened? Is the outlet controlled by a switch.</p> <p style="text-align: center;">NO</p> <p style="text-align: center;">Visit to check</p>	
<p>Water inlet trouble</p> 	<p>Is <i>IE</i> displayed?</p> <p style="text-align: center;">YES</p> <p>Is the tap opened?</p> <p style="text-align: center;">YES</p> <p>Is the tap frozen?</p> <p style="text-align: center;">NO</p> <p>Is the water supply shut-off?</p> <p style="text-align: center;">NO</p> <p>Is filter in the inlet valve clogged with foreign material?</p> <p style="text-align: center;">NO</p> <p style="text-align: center;">Visit to check</p>	    <p style="text-align: center;">YES</p> <p>Clean the filter of inlet valve</p> 

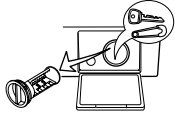
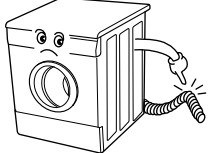
SYMPTOM	GUIDE FOR SERVICE CALL
<p>◦ DOOR OPEN ERROR</p> <p>Refer to 7-4 ERROR DISPLAY</p> 	<div style="display: flex; justify-content: space-between;"> <div style="width: 60%;"> <p>Did you press the Start / Pause button when the door is open?</p> <p style="text-align: center;">NO</p> <p style="text-align: center;">Visit to check</p> <p style="text-align: center;">Check if the door switch is O.K</p> </div> <div style="width: 35%;"> <p>YES</p> <p>Close the door</p>   </div> </div>
<p>◦ Drain Trouble</p> 	<div style="display: flex; justify-content: space-between;"> <div style="width: 60%;"> <p>Is dE displayed?</p> <p style="text-align: center;">YES</p> <p>Is the debris filter clogged with foreign material such as pins, coins, etc.?</p> <p style="text-align: center;">NO</p> <p>Is the drain hose frozen with water, kinked, or crushed?</p> <p style="text-align: center;">NO</p> <p style="text-align: center;">Visit to check</p> </div> <div style="width: 35%;">  <p>YES</p> <p>Clean up the filter.</p>   </div> </div>

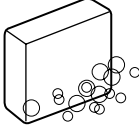
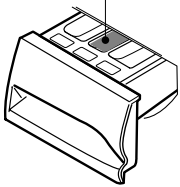
SYMPTOM	GUIDE FOR SERVICE CALL
<p>◦ Suds overflow from the appliance. (In this condition, wash and spin do not operate normally)</p>	<div style="display: flex; justify-content: space-between;"> <div style="width: 65%;"> <p>Is low-sudsing detergent for the drum washing machine used?</p> <p style="text-align: center;">YES</p> <p>Is the proper amount of detergent used as recommended?</p> <p style="text-align: center;">YES</p> <p>Recommend to reduce the amount of detergent.</p> <ul style="list-style-type: none"> * This appliance has the automatic suds sensing function which operates under much suds condition for good rinse and preventing overflow. * When much suds are sensed, the suds removing function such as drain, water input, and pause will operate without rotating the drum. </div> <div style="width: 30%; text-align: center;">  <p>LOW SUDSING DETERGENT</p> </div> </div>
<p>◦ No effect of softener</p>	<div style="display: flex; justify-content: space-between;"> <div style="width: 65%;"> <p>Is softener put in the correct compartment of drawer?</p> <p style="text-align: center;">YES</p> <p>Is the drawer closed during wash?</p> <p style="text-align: center;">YES</p> <p>Is the softener cap clogged?</p> <p style="text-align: center;">YES</p> <p>Explain how to use softener</p> <p>Clean the compartment for softener</p> </div> <div style="width: 30%; text-align: center;"> <p>Compartment for softener</p>  </div> </div>
<div style="display: flex; flex-direction: column; align-items: center; gap: 10px;"> <div style="border: 1px solid black; padding: 2px 10px; font-family: monospace; font-size: 1.2em;">FE</div> <div style="border: 1px solid black; padding: 2px 10px; font-family: monospace; font-size: 1.2em;">PE</div> <div style="border: 1px solid black; padding: 2px 10px; font-family: monospace; font-size: 1.2em;">LE</div> </div>	<p style="text-align: center;">Visit to check</p>

8-2.FAULT DIAGNOSIS AND TROUBLESHOOTING

CAUTION

1. Be careful of electric shock or disconnecting the parts while troubleshooting.
2. First of all, check the connection of each part terminal with wiring diagram.
3. If you replace the PWB assembly (Main), put in the connectors correctly.

NO POWER

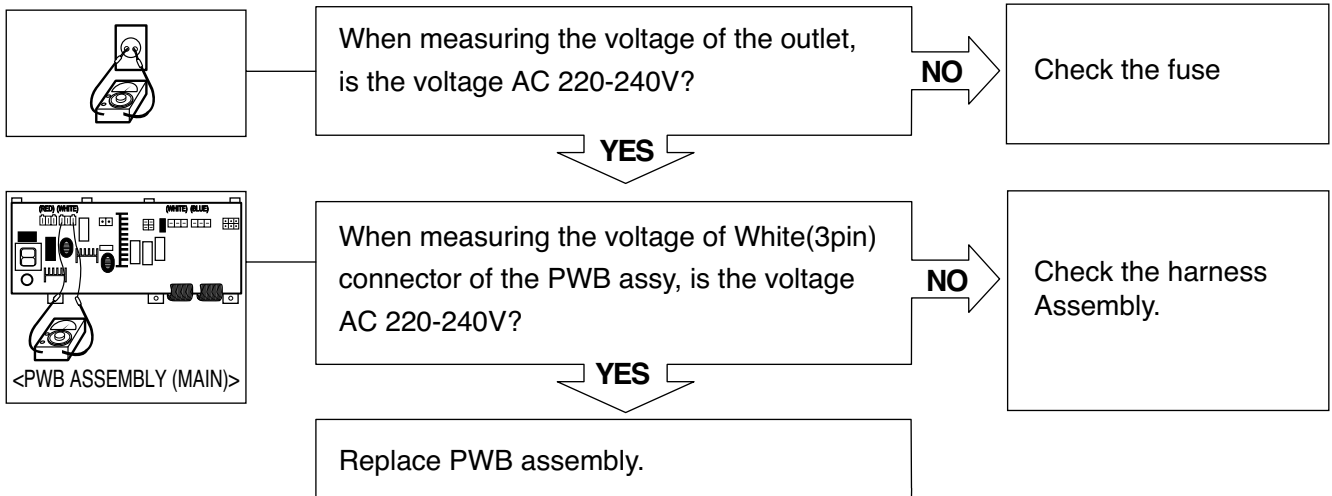

ALL BUTTONS ARE INOPERABLE EXCEPT POWER BUTTON

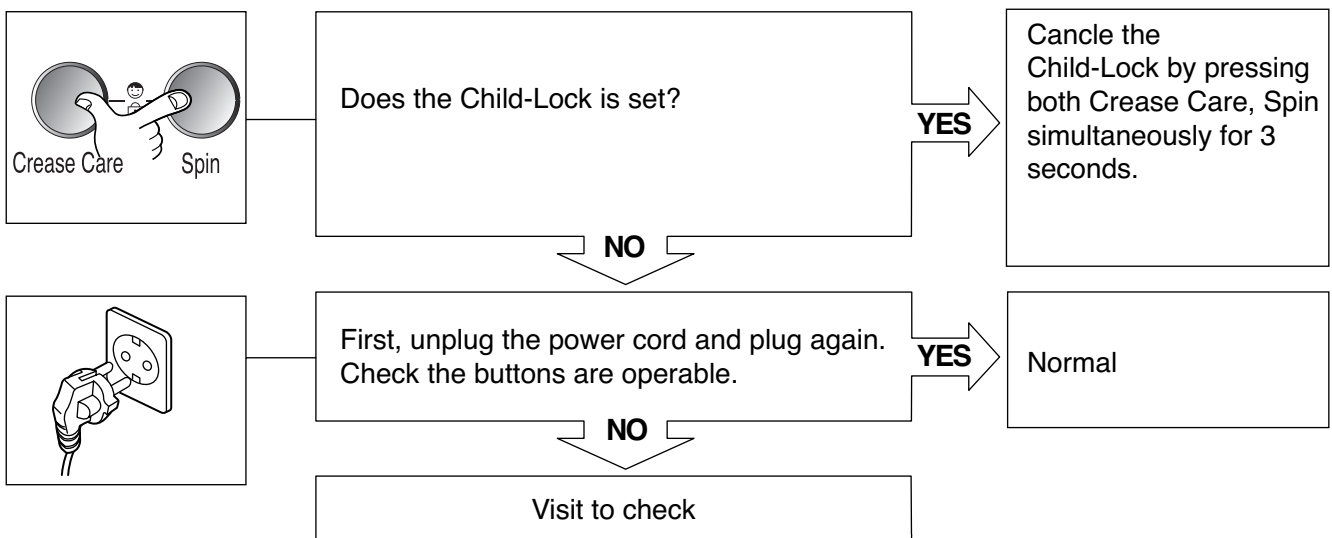

NO WATER SUPPLY

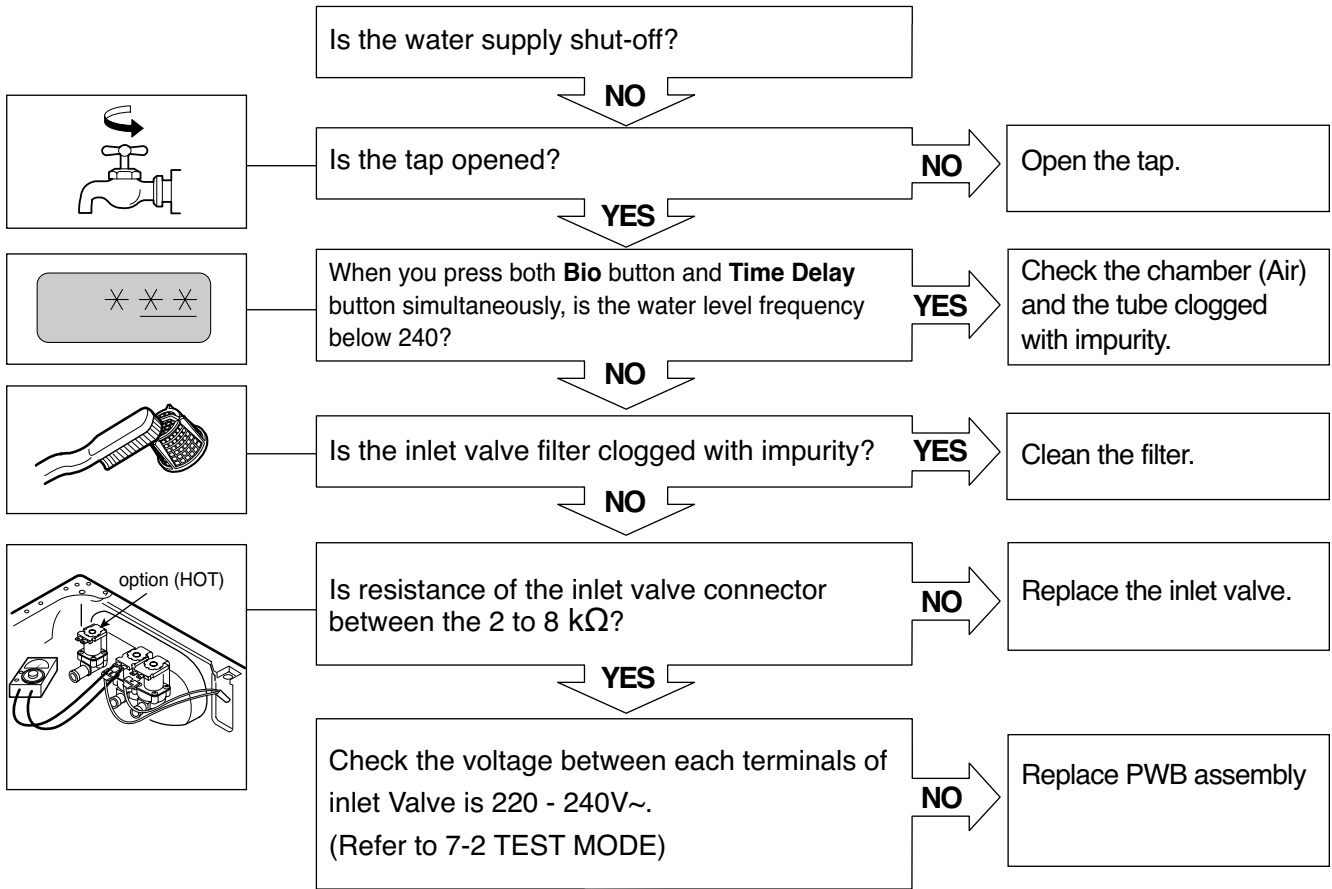

DETERGENT DOES NOT FLOW IN

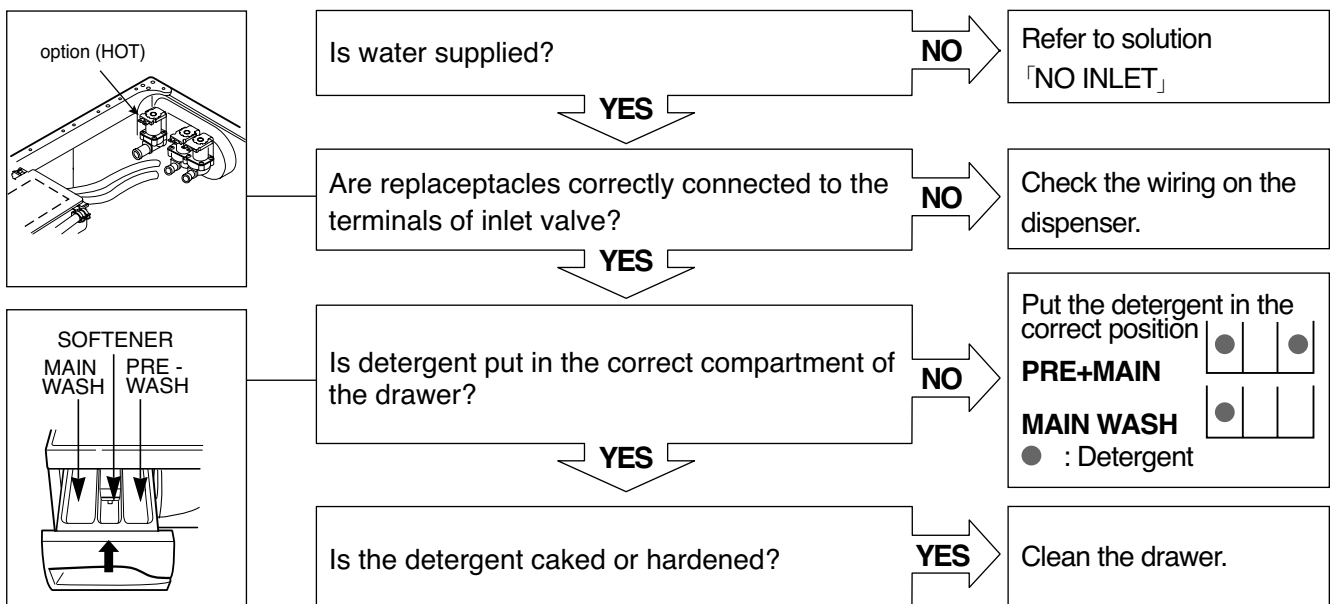

SOFTENER DOES NOT FLOW IN

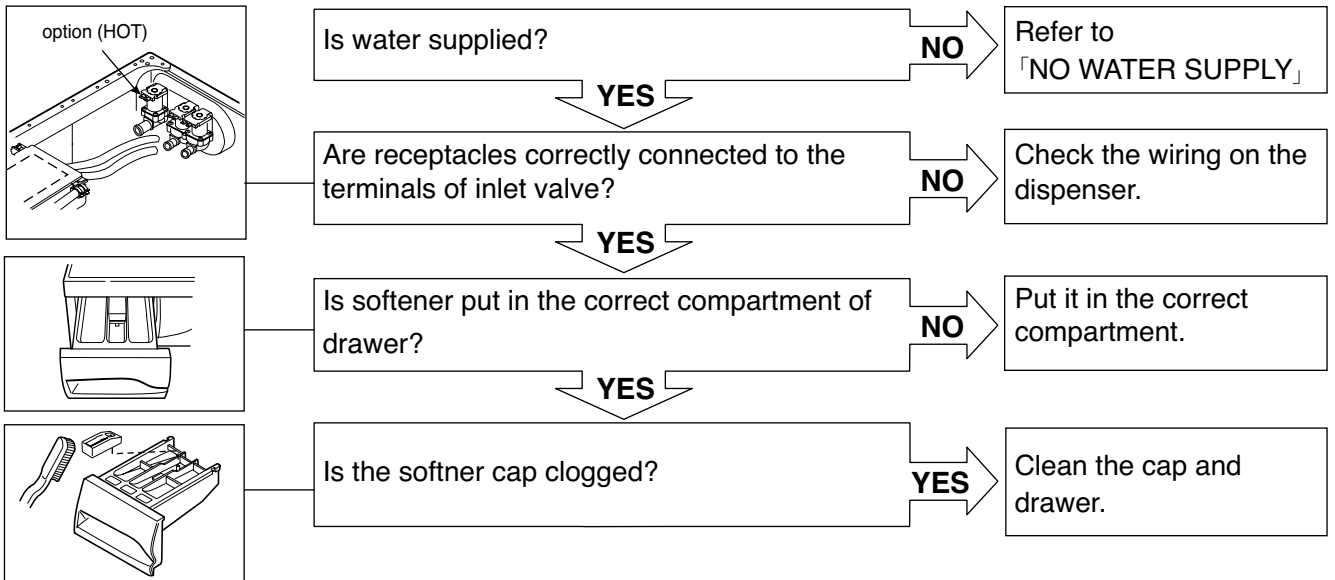

ABNORMAL SOUND

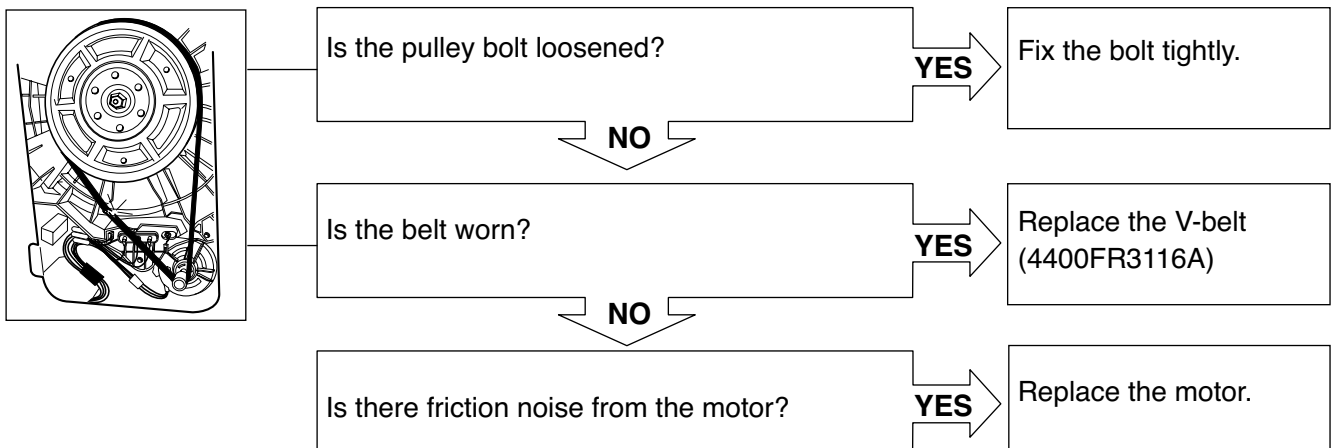

HEATING WITHOUT WATER

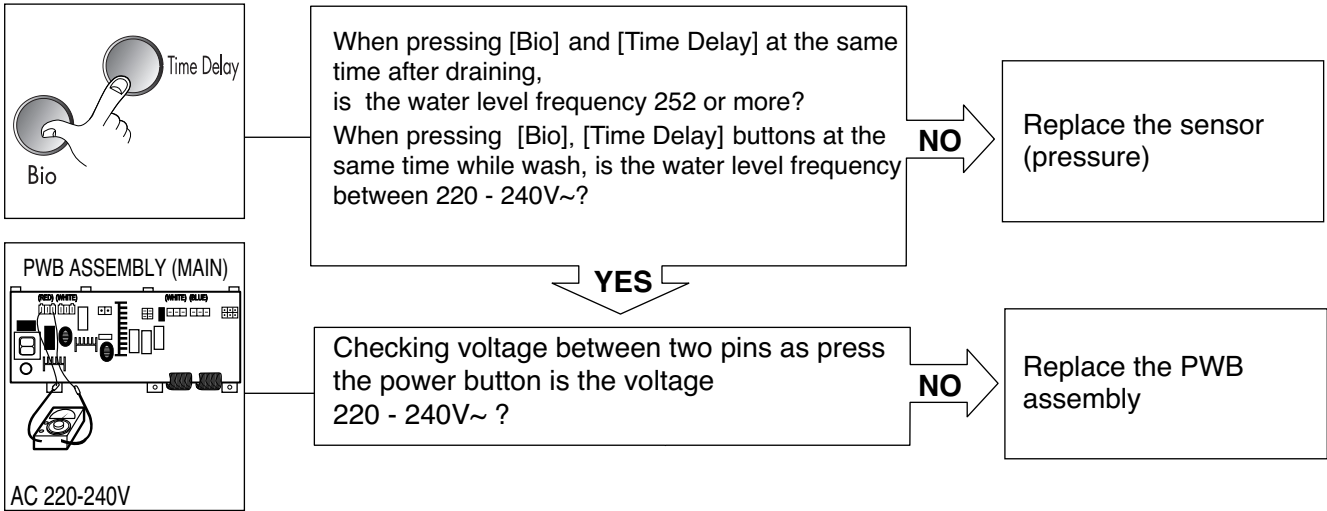

DRAIN MALFUNCTIONING

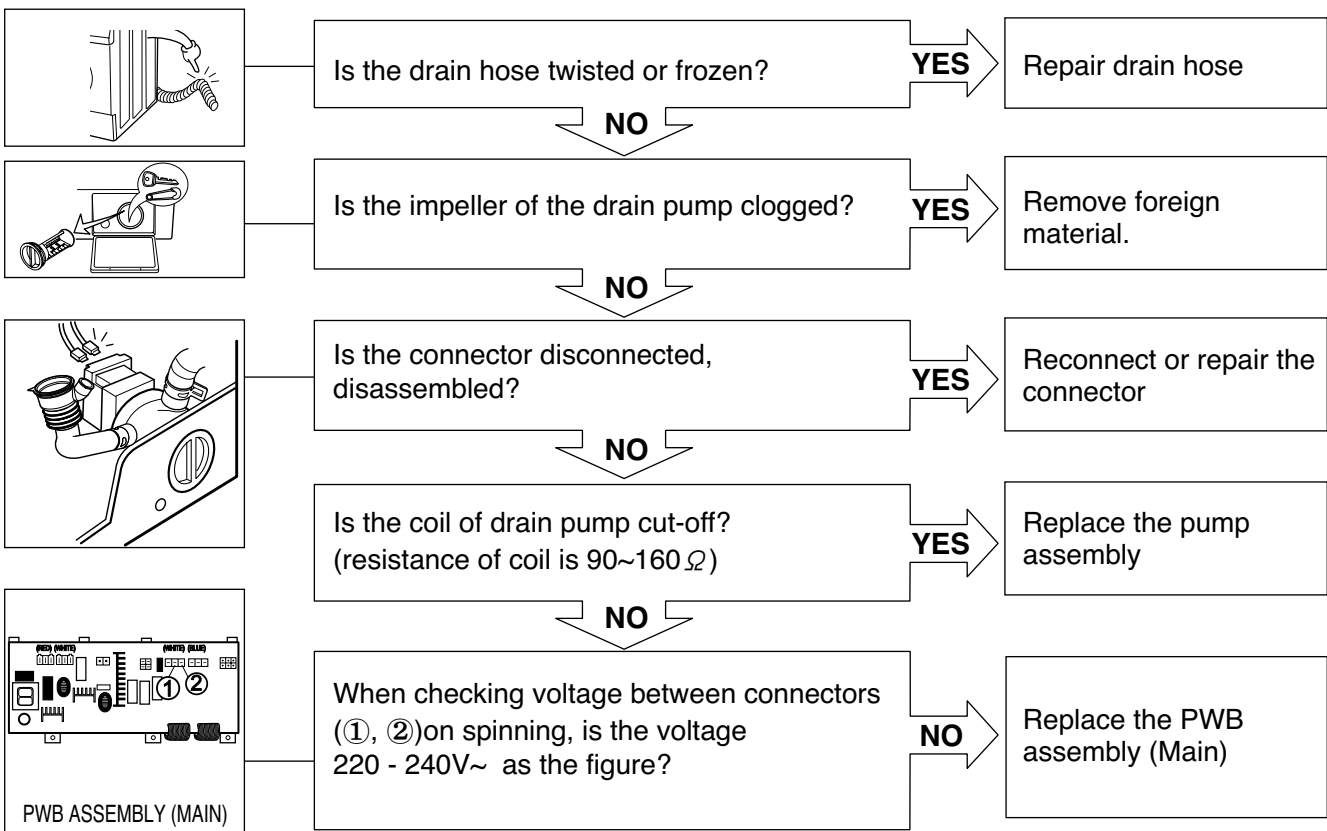

WASH HEATER TROUBLE

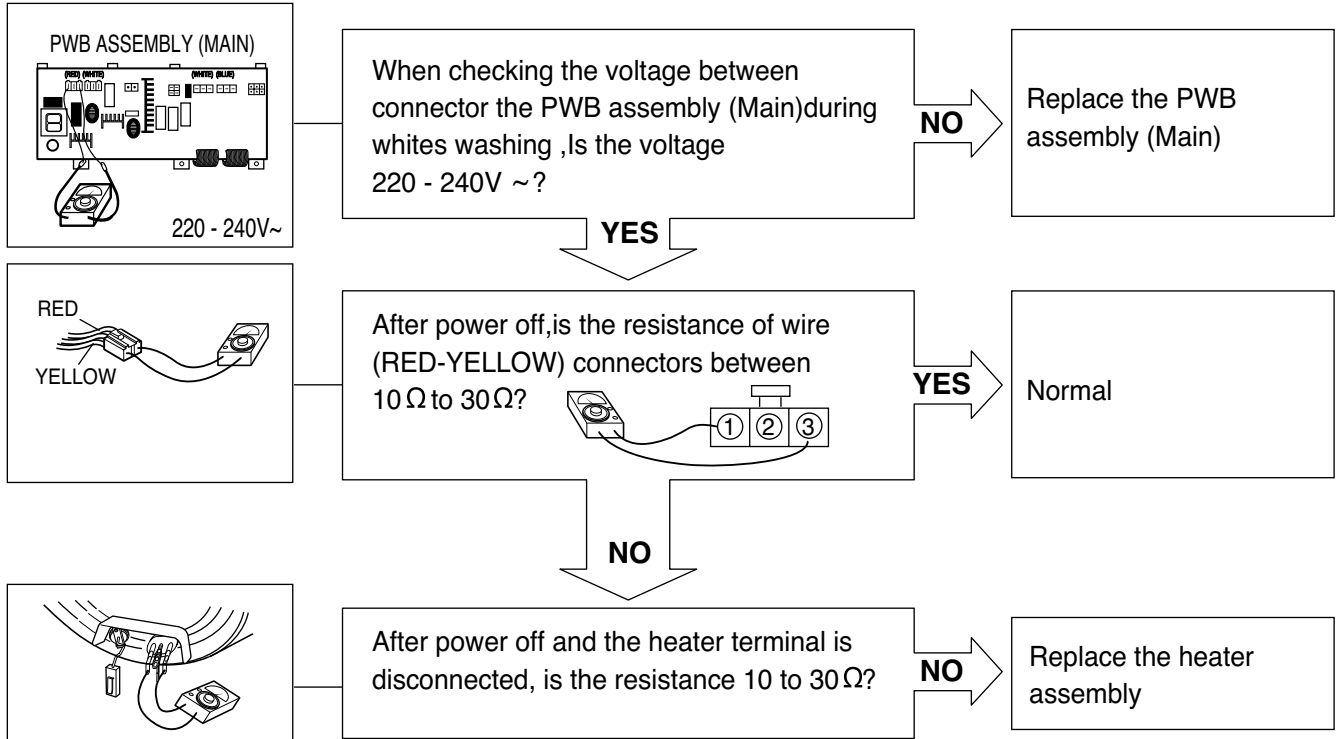

HEATING CONTINUOUSLY ABOVE THE SETTING WATER TEMPERATURE

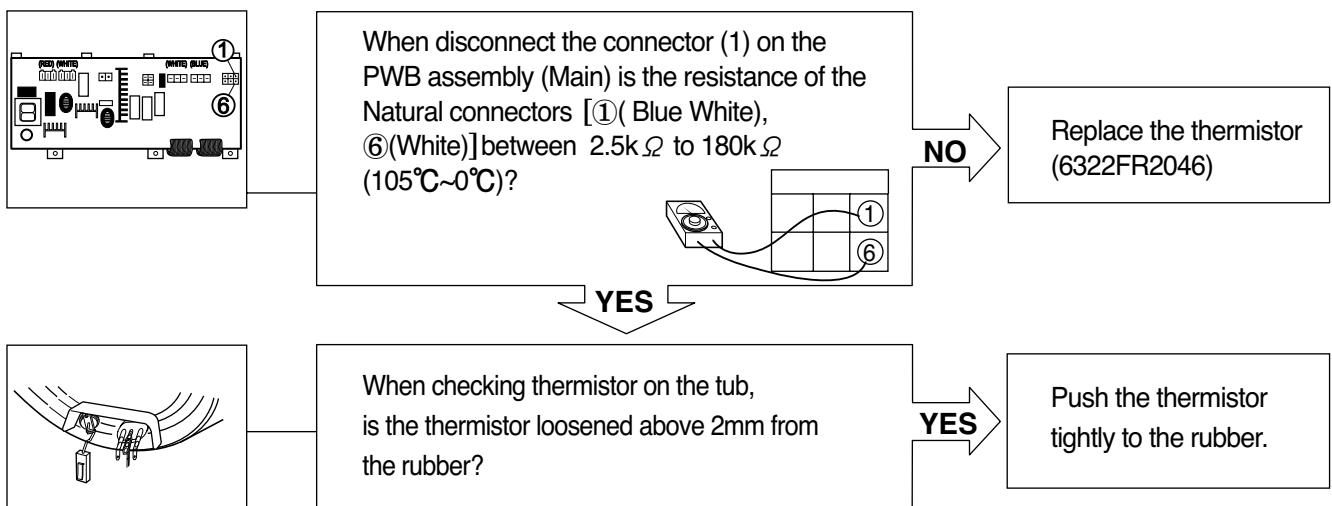

SPIN TROUBLE

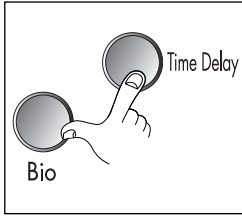

Check on the spinning, is the frequency of the water level 248 or more. The frequency can be checked by pressing the **Bio** and **Time Delay** buttons at the same time on the program.

NO

Check the sensor (Pressure) or hose (Sensor).
If the problem is on the sensor or the hose, replace the sensor or the hose.

YES

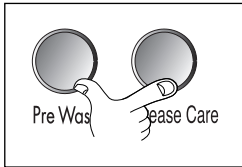

When pressing **Pre Wash** and **Crease Care** buttons at the same time after power off, press the **START / PAUSE** button 2 times, is the drum low speed spin?

YES

Normal

NO

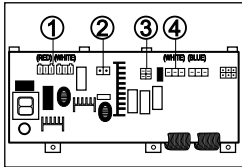

Is it disconnected, or disassembled?
[Red:3pin (①), White : 2pin(②), National:4pin(③), White:3pin(④)]

YES

Correct the connector.

NO

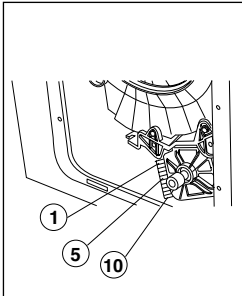

Check the motor connector, Is the resistance between the terminal in figure the same as below?

Resistance between terminals

① ~ ⑤ : 0.5~1.0Ω

⑤ ~ ⑩ : 1.5~2.5Ω

Be sure to unplug the machine before measuring.

MOTOR TERMINAL



NO

Replace the motor assembly.
(4681FR1194A)

YES

Replace the PWB assembly.

9. DISASSEMBLY INSTRUCTIONS

* Be sure to unplug the machine out of the outlet before disassembling and repairing the parts.

CONTROL PANEL

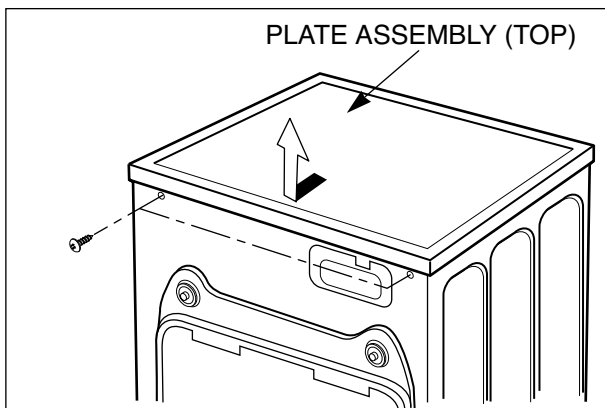

- ① Unscrew 2 screws on the back of the top plate.
- ② Pull the top plate backward and upward as shown.

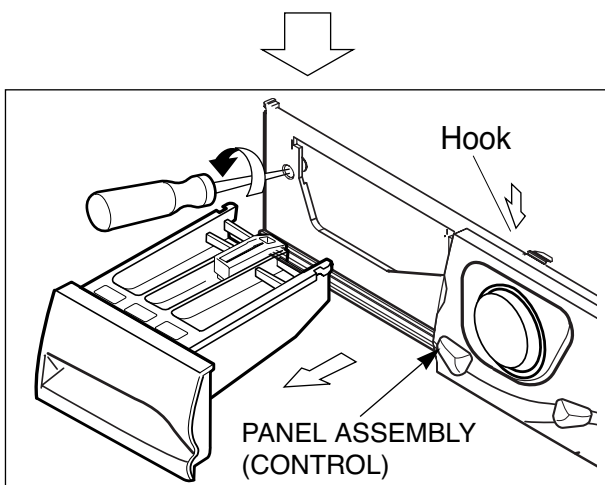

- ① Disconnect the PWB Assembly connector from Main lead wire Assembly.
- ② Pull out the drawer and unscrew 2 screws.
- ③ Push upper hooks down on the top and pull the control panel.

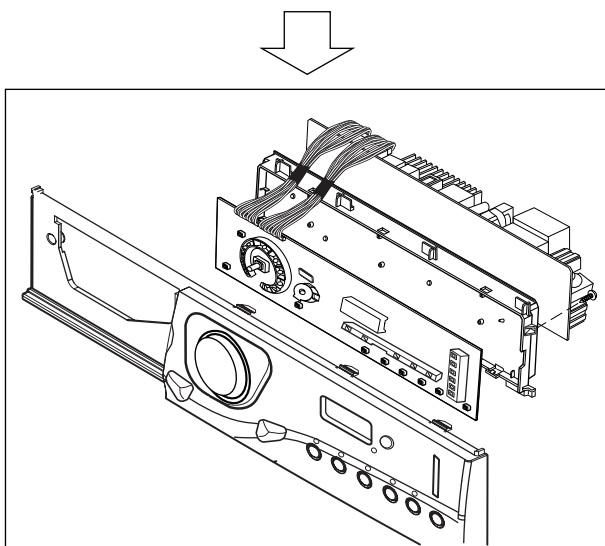

- ① Disconnect the PWB assembly (Main & Display) from the control panel by unscrew 3 screws.

DISPENSER ASSEMBLY

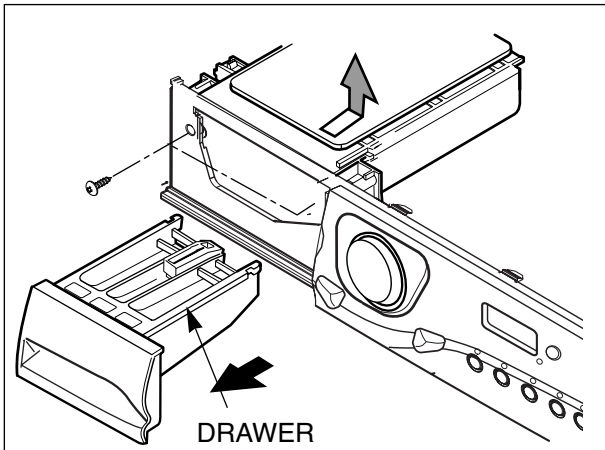

- ① Disassemble the top plate assembly.
- ② Pull out the drawer to arrow direction.
- ③ Unscrew 2 screws.

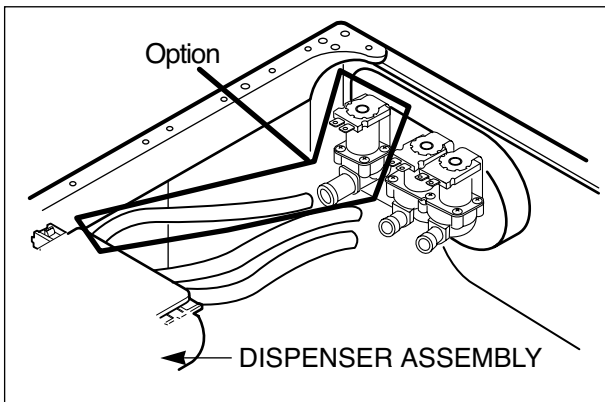

- ① The hose clamps and the hose are disassembled.

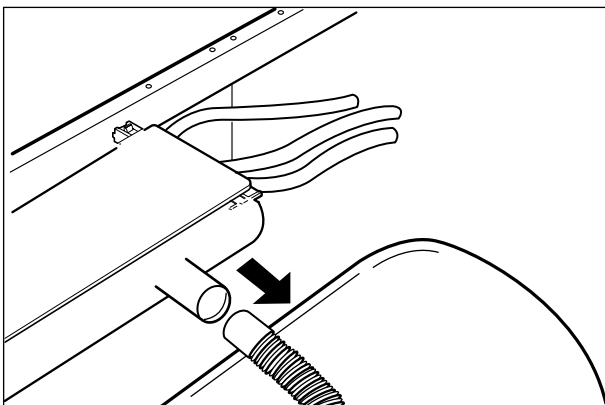

- ① The ventilation bellows and the water inlet bellows are disassembled on the tub.

INLET VALVE

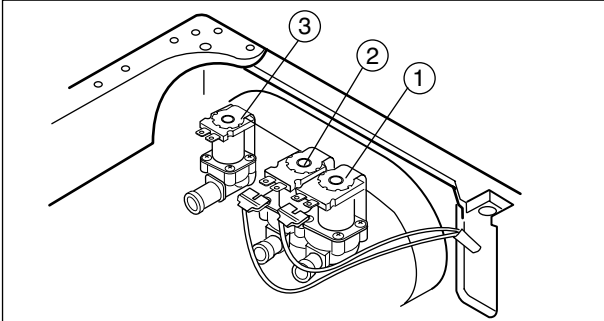

- ① Disconnect the wiring receptacle.
- ② Unscrew 2 screws from the back.
- ※ When reconnecting the connector

VALVE #1 (MAIN)	White / Black-Black
VALVE #2 (PRE)	Gray / White - Black
VALVE #3 (HOT)	Blue / Red - Black

LOWER COVER

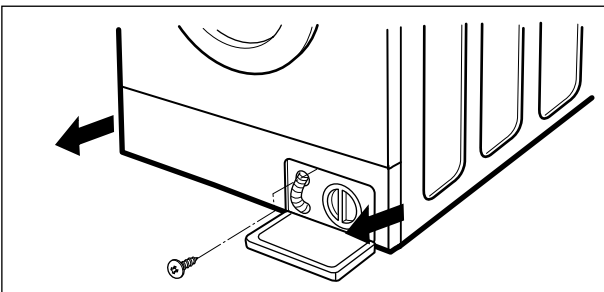

- Open the lower cover cap by using coin and pull out the lower cover in the arrow direction after a screw is unscrewed.

DOOR

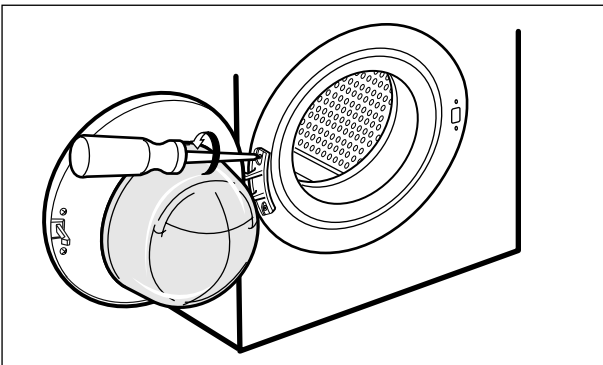

- ① Open the door completely.
- ② Remove the two screws from the hinge.
- ※ When removing the door assembly, it is necessary to hold the bracket that is inner of the cabinet cover.

GASKET ASSEMBLY

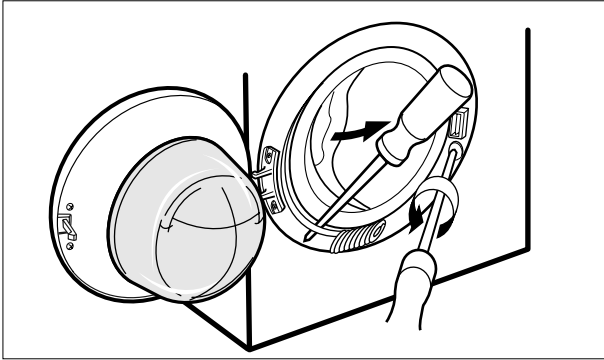

- ① Take apart the cabinet gasket clamp.
- ② Unscrew 2 screws from the cabinet cover.
- ③ Open the lower cover cap and unscrew 1 screw inside.
- ④ Take apart the lower cover.

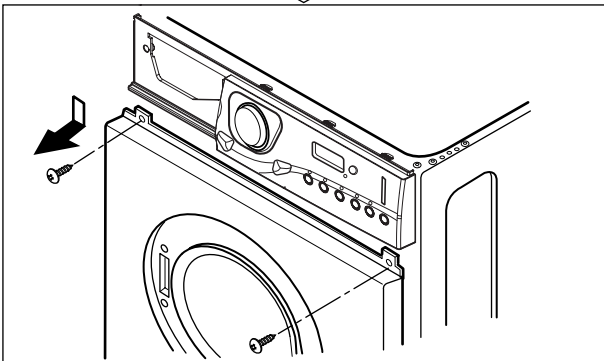

- ① Disassemble the control panel. (refer to the 25page)
- ② Unscrew all the screws on the upper and lower sides of the cabinet cover.

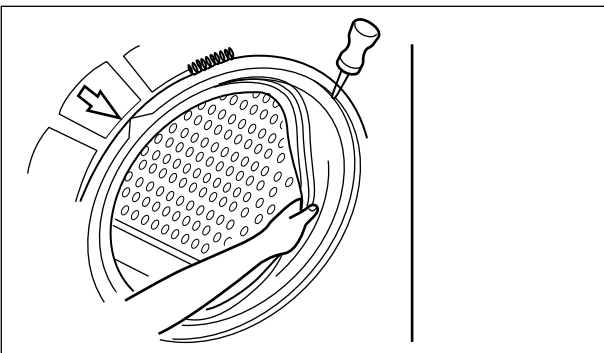

- ① Take apart the tub gasket clamp.
 - ② Make sure that the drain hole of the gasket is put beneath when reassembling the gasket.
- ※ Refer to the arrow mark on the tub cover.

PULLEY, MOTOR, DAMPER

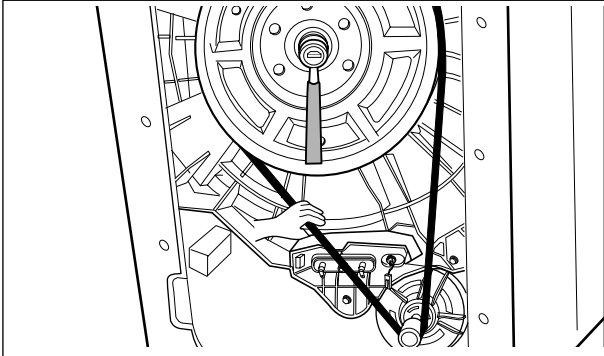

(PULLEY)

- ① Remove the back cover.
- ② Take off the belt turning the pulley.
- ③ Unscrew the bolt to pull out the pulley.

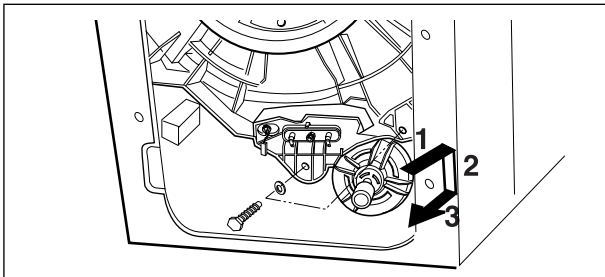

(MOTOR)

- ① Unscrew 2 screws from the bracket.
- ② Push the motor in the arrow direction for disassembling.
- ③ When reassembling the motor, make sure that motor mounting bushings are not taken off from the bracket.

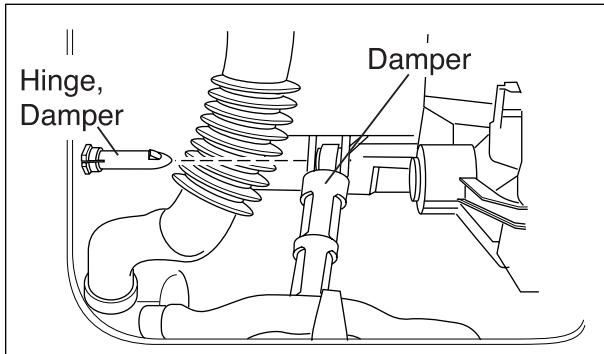

(DAMPER)

- ① Pull out the hinge, pressing its snap.
- ② Do not use the pulled out hinge again. It may be taken off during operation.

■ Clean the drain pump filter

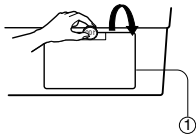

Open the lower cover cap (①) by using a coin. Turn the drain plug (②) to pull out the hose.

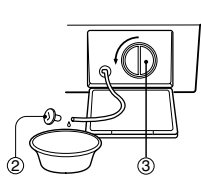

Unplug the drain plug (②), then the water flows out. At this time use a vessel to prevent water flowing on the floor. If the water does not flow any more, turn the pump filter (③) open to the left.

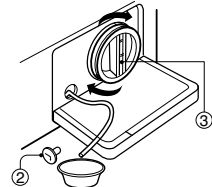

Take out any foreign material from the pump filter (③). After cleaning, turn the pump filter (③) clockwise and insert the drain plug (②) to the original place. Close the lower cover cap.

PUMP

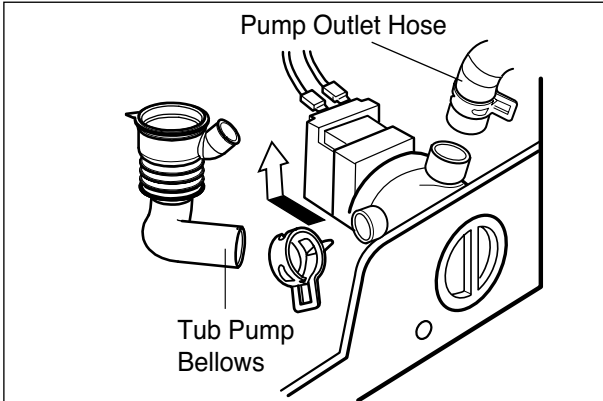

- ① Remove pump outlet hose.
- ② Remove tub pump bellows.
- ③ Remove cap (Remaining Hose.)
- ④ Disconnect the wiring.
- ⑤ Unscrew 2 screws.
- ⑥ Remove the pump.

HEATER

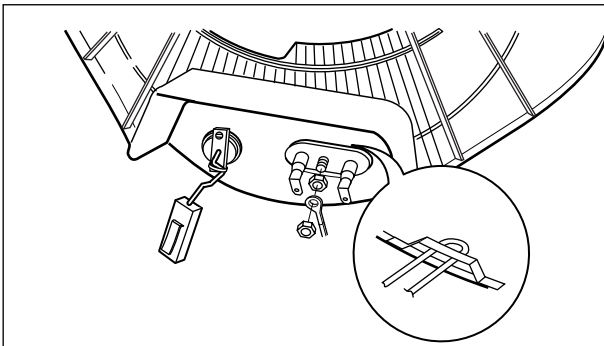

- ① Loosen the M6 heater nut to pull out the heater.

CAUTION

When mounting the heater, be sure to insert the heater into the heater clip on the bottom of the tub.

THERMISTOR

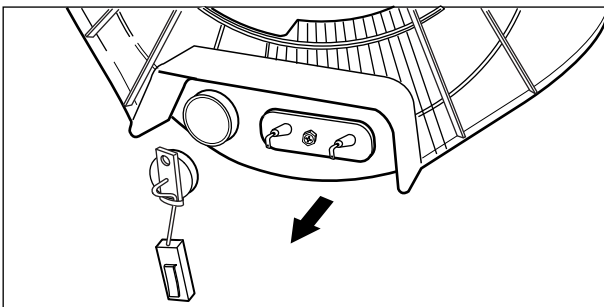

- ① Pull it out by holding the thermistor bracket.
 - * If it is pulled by the wire, it may be broken.
- ② When mounting the thermistor again, make sure that it is got back tight to the bushing.

SWITCH ASSEMBLY, DOOR LOCK

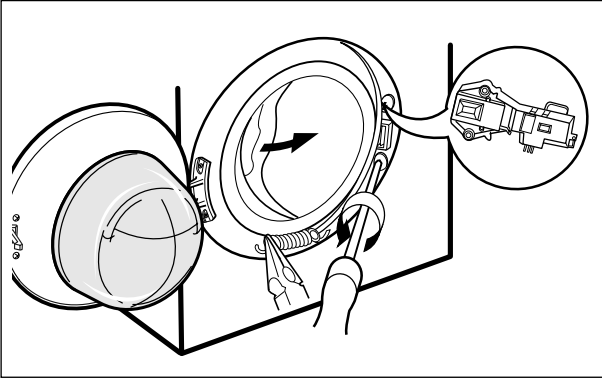

- ① Take apart the cabinet cover clamp and release the gasket.
- ② Unscrew 2 screws holding the door lock.
- ③ Disconnect the door lock from the wiring connector.

WHEN FOREIGN MATERIAL IS STUCK BETWEEN DRUM AND TUB

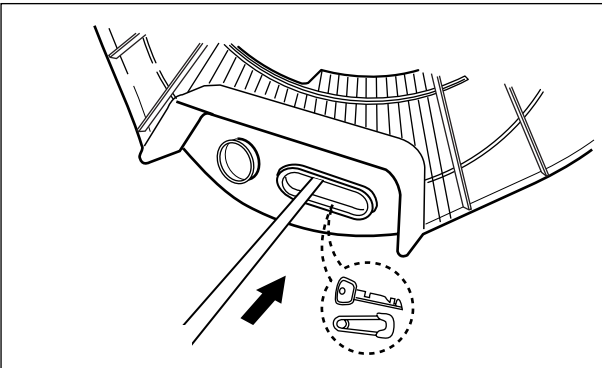

- ① Remove the heater.
- ② Remove the foreign material (wire, coin and others) by inserting a long bar through the hole.

10. EXPLODED VIEW

10-1. THE EXPLODED VIEW OF CABINET ASSEMBLY

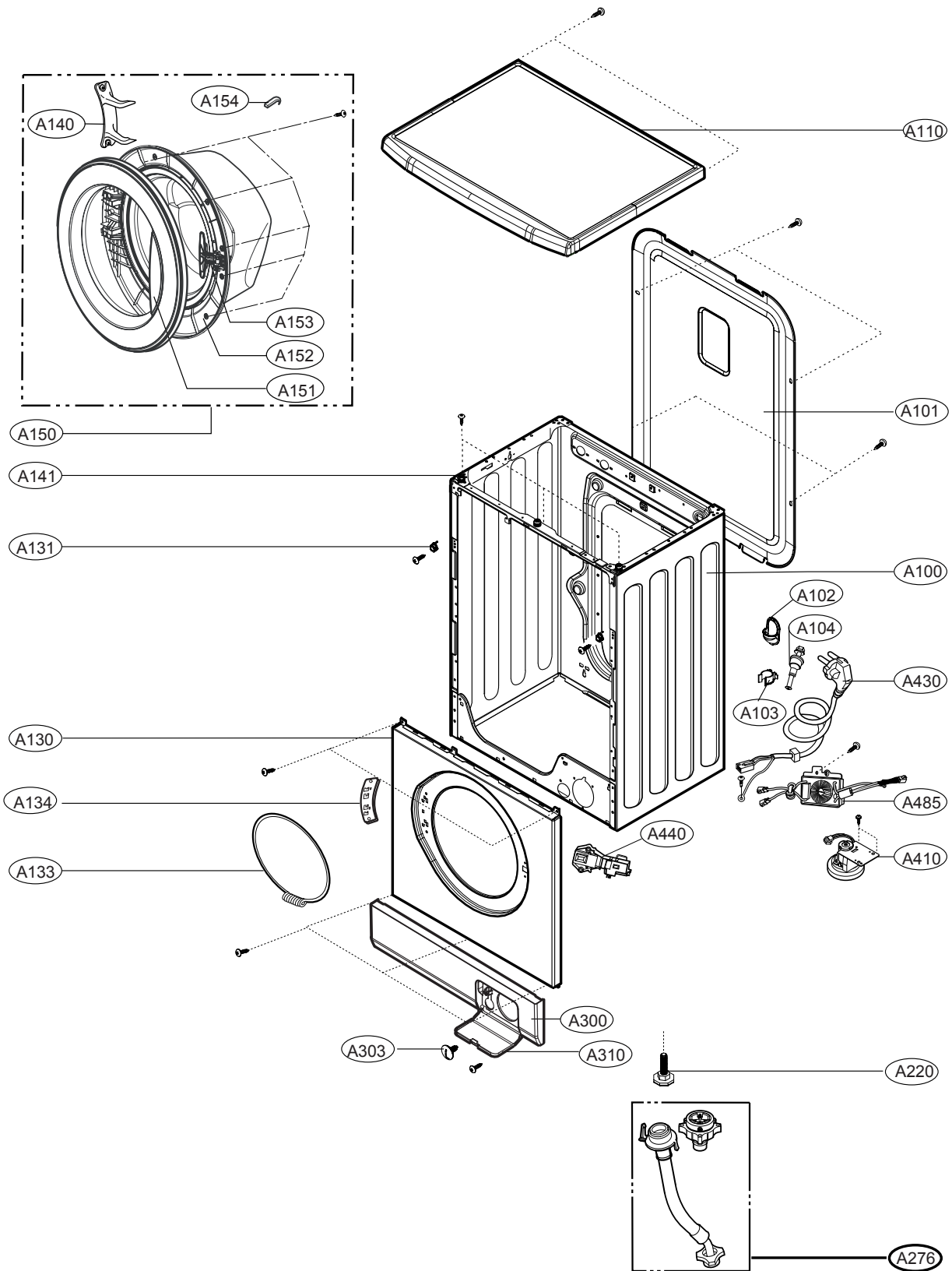

10- 2 THE EXPLODED VIEW OF CONTROL PANEL & DISPENSER ASSEMBLY

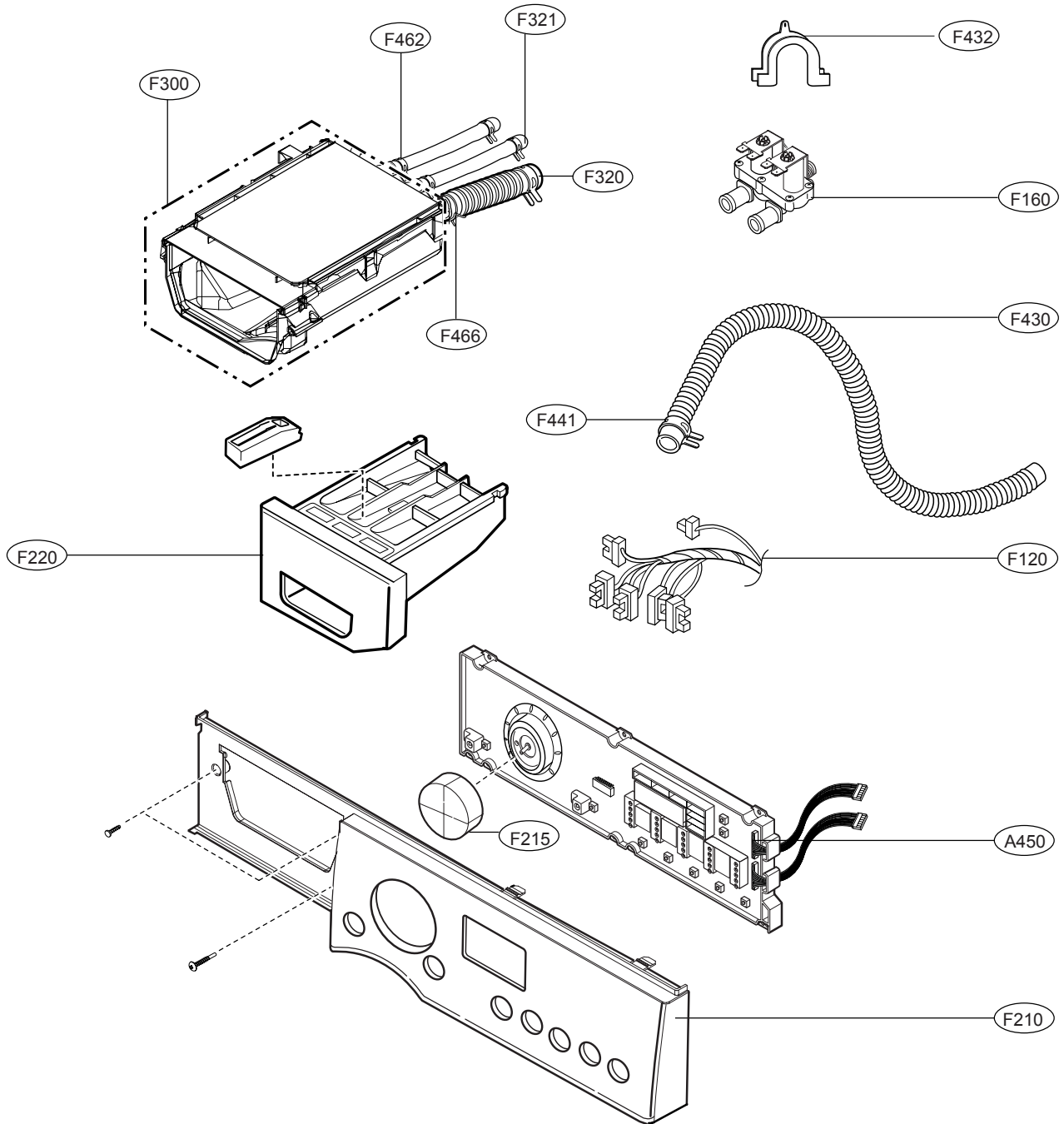

10- 3 THE EXPLODED VIEW OF DRUM & TUB ASSEMBLY

