

G210

Multiscanning Color Monitor

TECHNICAL SERVICE MANUAL



Safety Precaution

WARNING

Service should not be attempted by anyone unfamiliar with the necessary precautions on this monitor. The followings are the necessary precautions to be observed before servicing.

1. Always discharge the high voltage to the CRT conductive coating before handling the CRT.
The picture tube is highly evacuated and if broken, glass fragments will be violently exploded. Use shatter proof goggles and keep picture tube away from the bare body while handling.
2. When replacing a chassis in the cabinet, always be certain that all the protective devices are put back in place, such as nonmetallic control knobs, insulating covers, shields, isolation resistor capacitor network etc.
3. Before returning the monitor to the customer, always perform an AC leakage current check on the exposed metallic parts of the cabinet, such as signal connectors, terminals, screw heads, metal overlays, control shafts etc, to be sure the monitor is safe to operate without danger of electrical shock. Plug the AC line cord directly into a AC outlet (do not use a line isolation transformer during this check.). Use an AC voltmeter having 1500 ohm per volt or more sensitivity in the following manner : Connect ground(water pipe, conduit, etc.) and the exposed metallic parts, one at a time. Measure the AC Voltage across the combination of 1500 ohm resistor and 0.15 μ F capacitor. Reverse the AC plug at the AC outlet and repeat AC voltage measurements for each exposed metallic part. The Voltage must not exceed 0.3 volts RMS. This corresponds to 0.2 milliamp AC. Any value exceeded this limit constitutes a potential shock hazard and must be corrected immediately.

AC VOLTMETER

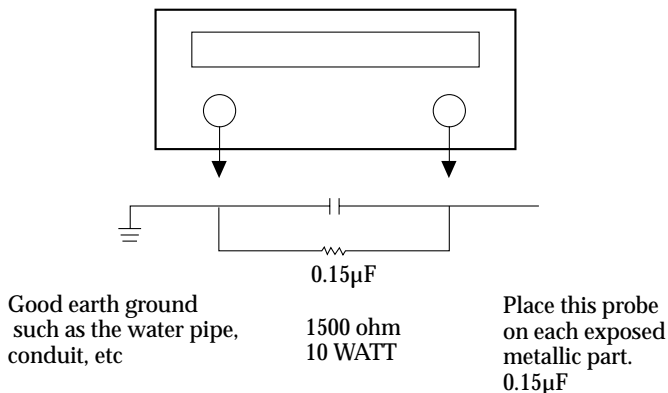

INSTRUCTIONS TO USER

This equipment generates and uses radio frequency energy and if not installed and used properly, that is, in strict accordance with the manufacturer's instruction, may cause interference to radio and television. It has been tested and found to comply with the limits for the specifications in Subpart J of Part 15 FCC Rules, which are designed to provide reasonable protection against such interference in a residential installation. However, there is no guarantee that interference will not occur in a particular installation.

If this equipment does cause interference to radio or television reception, which can be determined by turning the equipment off and on, the user is encouraged to try to correct the interference by one or more of the following measures.

- reorient the receiving antenna
- relocate the computer with respect to the receiver
- plug the computer into a different outlet so that computer and receiver are on different branch circuits.

X-Ray Radiation Precaution

1. Excessive high voltage can produce potentially hazardous X-RAY RADIATION. To avoid such hazards, the high voltage must be under the specified limit. The nominal value of the high voltage of this monitor is $26KV \pm 0.5KV$ at zero beam current (minimum brightness) under a 120V AC power source. The high voltage must not (under any circumstances) exceed 29.5KV. Each time a monitor requires servicing, the high voltage should be checked.
It is recommended the high voltage be recorded as a part of the service record. It is important to use an accurate and reliable high voltage meter.
2. This monitor is equipped with a protection circuit which prevents the monitor from producing excessively high voltage. Each time the monitor is serviced, the protection circuit must be checked to determine that the circuit is properly functioning.
3. The only source of X-RAY RADIATION in this monitor is the picture-tube.
For continued X-RAY RADIATION protection, the replacement tube must be exactly the same type tube as specified in the parts list.
4. Some parts in this monitor have special safety-related characteristics for X-RAY RADIATION protection.
For continued safety, parts replacement should be undertaken only after referring to the product safety notice.

PRODUCT SAFETY NOTICE

Many electrical and mechanical parts in this monitor have special safety-related characteristics. These characteristics are often not evident from visual inspection.

Replacement parts which have these special safety characteristics are identified in this manual; electrical components having such features identified by " \triangle " in the replacement parts list and schematic diagram.

For continued protection, replacement parts must be identical to those used in the original circuit. The use of substitute replacement parts which do not have the same safety characteristics as the factory recommended replacement parts shown in this service manual, may create shock, fire, X-RAY RADIATION or other hazards.

PRODUCT CDRH NOTICE

Electrical potentiometers which is marked as caution " \triangle " in parts list are critical components of safety & CDRH.

Therefore, for continued protection, replacements parts must be used it which is used in original PCB ASS'Y.

General Information

1. Description

This 21"(20" viewable) color display monitor is operated in R, G, B, drive mode input.

2. Operating instructions

2-1. External instructions

2-2. Front

Power LED, Power Switch, menu key, Select Key, UP/Down Key

2-3. Rear

Signal : 15 Pin D-Sub, BNC (Option)

Power : 3-pole receptacle

2-4. Service Instruction(internal controls)

153V, Focus, Screen, H-Center

2-5. OSD Controls

Contrast, Brightness, H/V-Position, Pincushion, Trapezoid, Parallelogram, Pincushion Balance, Pin-Corner Top, Pin-Corner Bottom, Rotation, H/V-Linearity, Color adjust, Language, Information, H/V-Delay, BNC/D-sub(*Option), Degauss, H/V-Moire, Recall, H/V-Convergence, Purity

3. Electrical Characteristics

3-1. 100-240 Volt 60Hz/50Hz for use all over the world.

This power supply is a 120 Watt(TYP.) multi output SMPS for monitor.

3-2. Video

Input : 0.7V p-p analog signal(at 75 ohm terminated)

Bandwidth : 230 MHz(Max. Dot Rate)

Polarity : Positive

3-3. Horizontal Drive

Level : TTL High : 2.4V min . Low : 0.4V max

Polarity : Negative or Positive

Frequency : 30KHz ~ 107 KHz

Sync on Green (Option)

Polarity : Negative

Sync Level : 280 mVmin

3-4. Vertical Drive

Level : TTL High : 2.4V min . Low : 0.4V max

Polarity : Negative or Positive

Frequency : 50Hz~150Hz

4. Model Description.

TCO95/99

CRT Type No: M51QBNXXXXXX

Control Description

Front View

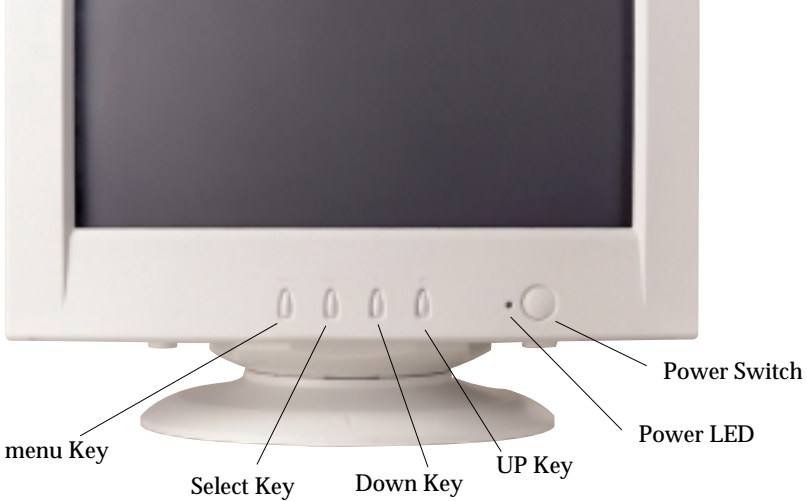

Video Input Signal

Recommended signals are shown below.

- Video Signal
 - Video Level : 0 to 700mV
 - Polarty : Positive
 - Video Input : RGB separated
 - Analog level
 - Sync input : H-Sync ; TTL level
 - V-Sync ; TTL level

- Waveform
 - Video input(R, G, B)

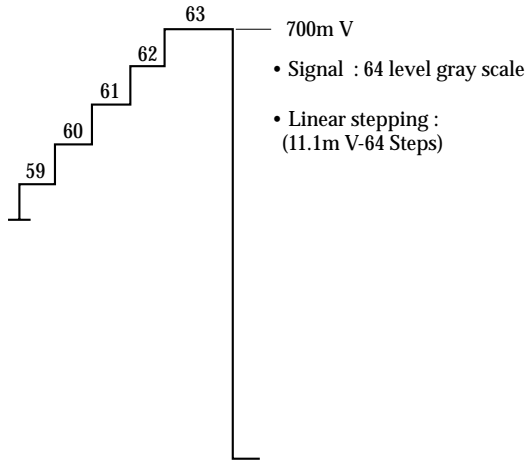
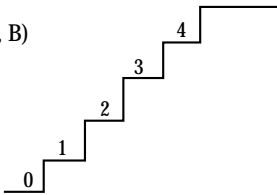

- H-Sync

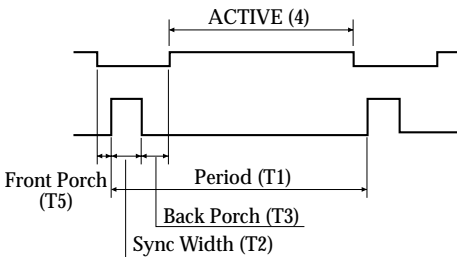

- V-Sync

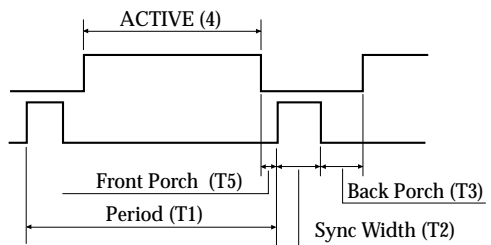

Timing table

Horizontal	Dot	720	640	640	800	1152	1024	1024	1280	1280	1600	1600
Frequency	kHz	31.469	31.469	63.657	53.674	67.500	68.677	81.845	79.976	91.146	93.750	106.25
Period(T1)	μs	31.778	31.778	15.709	18.631	14.815	14.561	12.219	12.504	10.971	10.677	9.412
Sync Width(T2)	μs	3.813	3.813	1.745	1.138	1.185	1.016	1.164	1.067	1.016	0.948	0.837
Back Porch(T3)	μs	1.907	1.907	1.745	2.702	2.370	2.201	1.455	1.837	1.422	1.501	1.325
Active(T4)	μs	25.422	25.422	11.636	14.222	10.667	10.836	9.309	9.481	8.127	7.901	6.972
Front Porch(T5)	μs	0.636	0.636	0.582	0.569	0.593	0.508	0.291	0.119	0.406	0.316	0.279

Vertical	Line	400	480	480	600	864	768	768	1024	1024	1200	1200
Frequency	Hz	70.087	59.940	120.110	85.061	75.000	84.997	100.795	75.025	85.024	75.000	85.000
Period(T1)	ms	14.268	16.683	8.325	11.756	13.333	11.765	9.922	13.329	11.761	13.333	11.765
Sync Width(T2)	ms	0.064	0.064	0.094	0.056	0.044	0.044	0.037	0.038	0.033	0.032	0.028
Back Porch(T3)	ms	1.080	1.048	0.566	0.503	0.474	0.524	0.464	0.475	0.483	0.491	0.433
Active(T4)	ms	12.711	15.253	7.450	11.179	12.800	11.183	9.384	12.804	11.235	12.800	11.294
Front Porch(T5)	ms	0.413	0.318	0.126	0.019	0.015	0.015	0.037	0.013	0.011	0.011	0.009
Interlaced	Y/N	N	N	N	N	N	N	N	N	N	N	N
Sync Polar	H	-	-	-	+	+	+	+	-	+	+	+
	V	+	-	-	+	+	+	+	-	+	+	+
Pixel Clock.	MHz	28.3	25.1	55.0	56.2	108.0	94.5	110.0	135.0	157.5	202.5	229.5

The monitor is compatible with additional modes within the specified frequency ranges provided that they are different at least for one of the following :

Horizontal Freq.: ± 1.2 kHz

Vertical Freq.: ± 1.2 Hz

Note: Even if the monitor detects the input timing as a factory preset mode, the size and position may not be able to be set as desired. Check the input timings are under the specifications and adjust the image as you want.

For better quality of display image, use the timing and polarity shown in the table above. Please see your video card user's guide to ensure compatibility.

Video Input Terminal

A 15 Pin D-sub connector is used as the input signal connector.
Pin and input signals are shown in the table below.

Pin Description

PIN NO. \ SIGNAL	SEPERATE SYNC	COMPOSITE SYNC
1	RED	RED
2	GREEN	GREEN
3	BLUE	BLUE
4	GROUND	GROUND
5	DDC RETURN	DDC RETURN
6	RED GROUND	RED GROUND
7	GREEN GROUND	GREEN GROUND
8	BLUE GROUND	BLUE GROUND
9	N.C	N.C
10	LOGIC GROUND	LOGIC GROUND
11	GROUND	GROUND
12	SDA	SDA
13	H-SYNC	(H+V) SYNC
14	V-SYNC(VCLK)	VCLK
15	SCL	SCL

D-Sub miniature connector

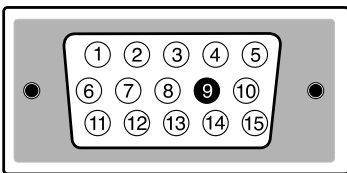

(Option)

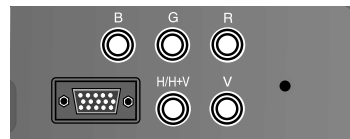

Connecting with External Equipment

Cautions

Be sure to turn off the power of your computer before connecting the monitor.

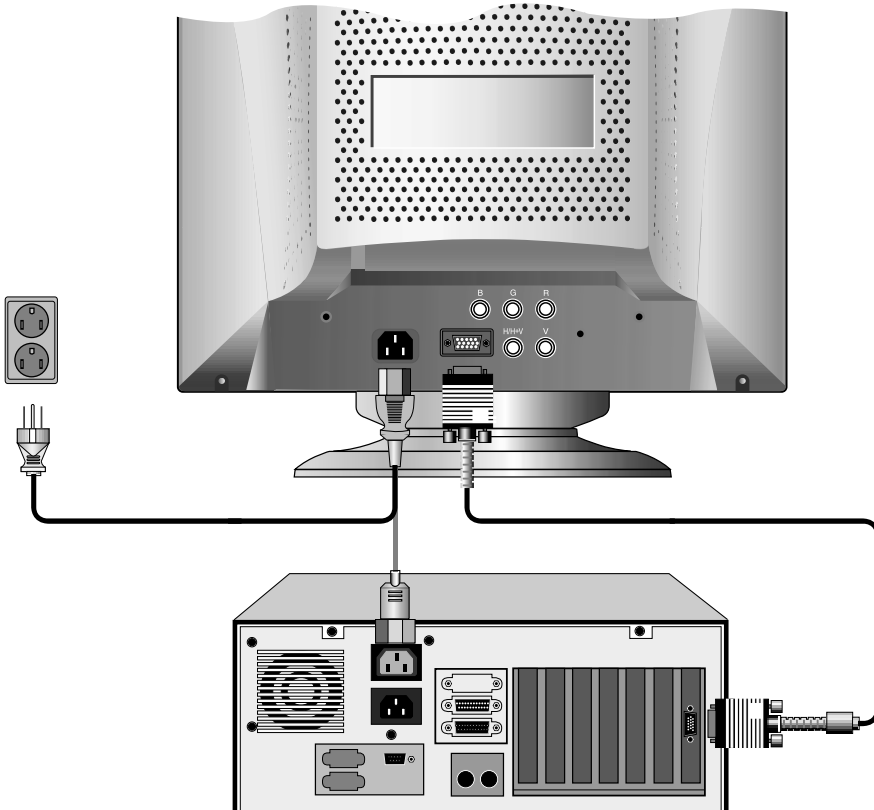

Theory of Operation

1. Power Supply

The AC voltage is from 90 ~ 264Vac.

The conducted noise is filtered by Line filter(LP1), Coil(LP2), X and Y

Capacitor(CP01,CP02,CP03,CP06).

NTC1 reduces the inrush current.

Bridge diode BD1 converts AC to DC.

And this DC voltage is charged CP04.

The STR-F6654 is a hybrid IC with a built in control IC and MOSFET.

The start-up circuit starts and stops the operation of the control IC by detecting the voltage appearing at the VIN (PIN4)

At start-up of the power supply, CP08 is charged through the start-up resistor RP09.

When the VIN(PIN4) voltage reaches 16V, the control circuit starts operation by the function of the start-up circuit.

(In normal state, VIN of ICP01 is supplied by CP08's dc voltage. In OFF MODE, VIN of ICP01 is supplied by CP07's dc voltage.)

The switching frequency is locked to Horizontal scan frequency by horizontal flyback pulse from sync trans transformer(TP02).

The output pulse width is controlled by current of OCP/F.B (PIN1)

The SMPS output has 205V,130V,80V,-12V,6.3V,12VA,12VB

*** Refer to the Schematics in the Page 62 (Schematic Diagram 4-1)**

Theory of Circuit Operation

Micro Controller System

The micro controller system is composed of the MCU, the serial E²PROM, key control circuit.

*** Refer to the Schematics in the Page 63 (Schematic Diagram 4-2)**

The MCU (ICM01, WT62P1) mainly provides the following functions:

- 1) Detect the system input signals and send proper control signals via general purpose I/O pins.
- 2) Output 4 PWM's to adjust the voltage controlled functions such as Brightness, Rotation, H-Linearity, ACL.
- 3) Control the following characteristics of the deflection IC TDA4841 and the video pre-amp KA2506 via I²C bus:
 - a. TDA4841:
 - H-Phase (H-Position), H-Size
 - V-Size, V-Position
 - Pincushion, Pin-Balance
 - Trapezoid, Parallelogram
 - H-Corner Top, Bottom
 - H-PinBal
 - H/V-Moire
 - H-Linearity
 - V-Linearity
 - H-Focus
 - b. KA2506:
 - Contrast
 - R,G,B gain
 - R,G,B cut-off
- 4) Control the OSD IC MTV021 via I²C bus to display the monitor status.
- 5) Detect the input sync characteristics via BNC/DSub input, identify the input timing, read the according settings in the E²PROM and then send proper controls such as CS-switch LEDs display, Contrast, Brightness, H-Size, H-Pos, ..., etc.
- 6) Monitor the level of ADC input ABL and then send the proper contrast setting in KA2506-01 to achieve the beam current limitation .
- 7) Set and detect the key board status and implement the One-Touch-Control function via ADC input KEY and encoder signals.
- 8) Provide the DDC1 /2B interface to PC system.

The serial E²PROMle memory device to reserve the fixed monitor parameters, the factory alignment result, the user adjusting result, the user defined timing characteristics,etc.

DPMS Mode

The power supply supports DPMS function. Its operation is shown in the below table.

MODE	H/V -Sync	205V	130V	-12V	80V	16V	12VA	5V	6.3V	12VB	H MCU 39	V MCU 40
NORMAL	O / O	205V	130V	-12V	80V	16V	12V	5V	6.3V	12V	H	H
STAND-BY	X / O	205V	130V	-12V	80V	16V	0V	5V	3.8V	0V	L	H
SUSPEND	O / X	46V	34V	0V	16V	17V	0V	5V	0V	0V	H	L
OFF	X / X	-	-	0V	16V	17V	0V	5V	0V	0V	L	L

Interface board

ICI01(BA7657S) is analog switching IC.

According to the state of pin16 ICI01 is switching 15 pin D-sub or BNC signal.

The default state is selecting 15 pin D-sub signal.

Microcontroller

CS Control table

H-Freq. [kHz]	CS ₁ QH09 Pin30	CS ₂ QH19 Pin29	CS ₃ QH11 Pin28	CS ₄ QH13 Pin27	CS ₅ QH15 Pin26
31 < 34K	ON	ON	ON	ON	ON
34 < 40K	OFF	ON	OFF	ON	ON
40 < 46K	ON	OFF	ON	ON	ON
46 < 51K	ON	OFF	ON	ON	OFF
51 < 56K	ON	OFF	OFF	OFF	ON
56 < 62K	ON	OFF	OFF	OFF	OFF
62 < 67K	OFF	OFF	ON	ON	ON
67 < 73K	OFF	OFF	ON	OFF	ON
73 < 79K	OFF	OFF	ON	OFF	OFF
79 < 85K	OFF	OFF	OFF	ON	ON
85 < 92K	OFF	OFF	OFF	OFF	ON
92 < 97K	OFF	OFF	OFF	ON	OFF
97 < 110K	OFF	OFF	OFF	OFF	OFF

High Voltage Control Circuit:

High Voltage Control Circuit is working basically by using switching theory with the main component ICF01 (KA3843). Circuit operating theory is explained as following:

* Refer to the Schematics in the Page 65 (Schematic Diagram 4-4)

- 1) When Power ON and the Vcc DC level of pin7 of ICF01 (KA3843) exceeding 8.4V, ICF01 starts to work and the oscillate frequency is decided by RF04, CF04.
- 2) When ICH2 is working normally the output square wave of pin6 will turn on QF01. The ON/OFF cycle of QF01 will make the primary of FBT(pin 1~2) acted like a Switching Power X'FMR.
- 3) AFC signal is differential by CF05, RF06 and connected with CF04 in order to force ICF01 in synchronization. Then, the high voltage will be always synchronized with horizontal deflection.
- 4) Usually loading change will cause unstable condition, so a high voltage feed back system is designed to maintain the stability of the high voltage circuit. This feed back system is started from voltage sensor on the pin12 of the FBT. This sensor voltage compares with voltage of the OP1 via the buffer(OP2) of LM358 and returns to ICF01.

LM358 OP1 is controlled by following factors:

- 1) A feed back reference high voltage circuit that consists of RF21, VRF01 and RF20 to adjust the high voltage.
- 2) During the period the horizontal frequency is changed, for example, H-UnLock will be from low to high (the time frequency changes). H-UnLock is controlled by pin 17 (H-UnLock) of ICH01 TDA4841. After differential circuit that consists of RF17 and RF18, the signal will turn QF03 on when frequency changed and reduce the high voltage by paralleling with RF21, VRF01 and RF20.

X-RAY High Voltage Protection CRT

X-RAY High Voltage Protection CRT is to get a DC level voltage by utilizing the output waveform of FBT's pin4 to pin9(GND) via a rectifier consists of DH18, CH45. This DC level voltage inputs to the pin2 (X-RAY) of ICH01 TDA4841. The preset X-RAY protection voltage is 6.3V. If the high voltage is higher than the preset voltage, the DC level voltage input into the pin2 will also be higher than 6.3V. It also means the HD signal is off, then horizontal deflection is off and the high voltage is also off.

Video-Amplifier/On-Screen-Display

The video amplifier system is consist of the Pre-Amplifier, the Video-Power-Amplifier, and the Cutoff-Voltage-Adjusting circuits.

The functions of the Pre-Amplifier ICC01(KA2506) include:

* Refer to the Schematics in the Page 64 (Schematic Diagram 4-3)

- 1) The small signal video amplifier controlled by MCU via I²C bus for the features of contrast(main gain control), 3 sub cut-off controls(R Cut-off, G Cut-off, B Cut-off), clamping pulse source and the clamping pulse width.
- 2) The OSD mixer processes the OSD-R, OSD-G, OSD-B on Pin13,14,15 and the OSD Blk input on Pin1 and the OSD contrast is controlled by MCU via I²C bus.
- 3) The H-Blanking signal is sent to the pin19 of 01.
To turn off the Horizontal scan Line during horizontal retrace period.

The Video-Power-Amplifier ICC03 is a 3-channel hybrid-IC which functions as a cascade type transistor amplifier to reach the high bandwidth performance.

The Cutoff-Adjusting circuit consist of QC03, QC05, QC07, QC04, QC06 and QC08 is to provide the function of dark /background white-balance control by varying the peak voltages on the CRT cathodes. ICC03(LM2402) serving as the OSD generator outputs the R,G,B,FBKG(FBLK) signals that contain the information by which the MCU shows the monitor's status and the user adjusting indications. The R,G,B,FBKG signals are synchronized by the horizontal and vertical deflection sync input on Pin5 and Pin10. The MCU controls the OSD via the signals,SDA,SCL on Pin 7,8.

Horizontal Deflection B+ Control Circuit

H/V Processing circuit

H/V Processing IC TDA4841 is I2C-autosync deflection controller for PC monitor.

All functions are controllable by I2C-bus.

The TDA4841 provides synchronization processing, horizontal and vertical synchronization with full autosync capability.

HSYNC(Pin15) is the input horizontal synchronization signals, which can be DC-coupled TTL signals and AC-coupled negative-going video sync signals.

The IC generates the drive waveforms for DC-coupled vertical boosters such as TDA4841 and KA2142

The TDA4856 provides extended functions e.g. as a flexible B+ control, an extensive set of geometry control facilities, and an combined output for horizontal and vertical focus signals.

External power components are given a great deal of protection.

The X-ray protection input X-Ray (Pin2) provides a voltage detector with a precise threshold.

In normal state, the pin2 voltage is about 5.3V. If increasing the high voltage, pin2 voltage is increased.

When pin2 voltage exceeds about 6.3V, TDA4856 is forced into protection mode.

In this mode several pins are forced into defined states:

HUNLOCK is flouting

Horizontal output stage (HDRV) is flouting

B+ control driver stage (BDRV) is flouting

CLBL provides a continuous blanking signal

The supply voltage of the IC must be switched off for a certain time, before the IC can be restarted again using the standard power-on procedure.

*** Refer to the Schemathics in the Page 63 (Schematic Diagram 4-2)**

Horizontal Drive /B+ Drive circuit

H/B+ Drive signal (square pulse) is generated from ICH01 pin 8/6.
 The H Drive signal is switching QH05, and H-drive trans amplify QH06's base drive current.
 B+ Drive signal is amplified by push pull (QH02, QH03) amplifier; this amplified signal the switching B+ voltage is supplied horizontal deflection coil through coil (TH02)

*** Refer to the Schematics in the Page 65 (Schematic Diagram 4-4)**

Brightness Blanking Reset Control CRT

*** Refer to the Schematics in the Page 65 (Schematic Diagram 4-4)**

Change the Brightness level by controlling the G1.

- 1) In normal working condition, the G1 waveform is synchronized with the vertical sync. Since the purpose is to blank the vertical flyback scanning line when vertical is flyback, so the Clamp/Blanking pulse of ICH1 pin16 through QF07 is used to control it.
- 2) Brightness control is via the control at pin35 of ICM01(WT62P1) and through the control at QF04 and QF05 to control the DC level of G₁

Focus CRT

*** Refer to the Schematics in the Page 65 (Schematic Diagram 4-4)**

Dynamic Focus is used to get perfect focusing of each dot on the screen. There are H-Focus and V-Focus:

ICH01 Pin 32 outputs a parabolic waveform (H+V Focus).
 QF08, QF09, QF13 amplify this focus signal.

Vertical Deflection CRT

*** Refer to the Schematics in the Page 62 (Schematic Diagram 4-1)**

Vertical deflection Saw-tooth waveform is provided by ICH01 pin12, 13 (VOUT1, 2) and Vout1, Vout2 is input to Vertical Amplified IC(KA2142) Pin 1,10
 This Signal is Amplified by ICV01(KA2142) and output via out pin6 of KA2142

Trouble Shooting

Symptom	Check 1. (OK ↓ NO →)	Check 2. (OK ↓ NO →)	Action
1. No power	1) Check CP04 voltage	1) Check FP01 (short?) 2) Check BDP01 (diode test) 3) Check input voltage	Change Change
	2) Check ICP01 (1) Check #4 (Vcc) (=16V)	1) Check RP09 2) Check DP04,DP09,DP03,DP02	Change Change
	(2) Check #1 wave form	1) Check DP06 (diode test)06 Check ICP06	Change Change
	(3) Check #3 wave form	Change ICP01 (#3 dead)	Change
	(4) Check TP01		
2. No high voltage	1) Check 130V (DP23 anode)	1) Check no power 2) Check 130V line CRT B/D QC03,04,05,06,07,08	Change
	2) Check TH05 #2 voltage (130V)	1) Check LF01,ICF01 open	
	3) Check ICF01 #6 wave form	1) Check ICF01 #7(Vcc 12V) 2) Check ICF01	Check 12Vline Change
	4) Check QF01 gate wave form	1) Check RF08,DF13	Change
	5) Check TH05 #1 wave form	1) Check DF02,DF03,CF09,QF01	Change
	6) Check TH05		
3. No deflection	1) Check QH06 base wave form	1) Check ICH01 #8 wave form	1) Check ICH01
		2) Check QH05 Gate waveform	1) Check QH06 2) Check 12VB line
		3) Check QH05 Drain wave form	1) Check QH06 2) Check16V line
	2) Check QH04 Source wave form	1) Check LH01,RH27	1) Check QH01,02,03
		2) Check QH02 Emitter wave form 3) Check QH04 4) Check DH02, 03	2) Check 12VB line

Symptom	Check 1. (OK ↓ NO →)	Check 2. (OK ↓ NO →)	Action
4. No video	1) Check video input (CRT B/D (CNC2 #1, 3, 5 wave form)	1) Check ICI01 video input (ICI1 #1, 3, 5/#7, 9, 11 wave form)	1) Check signal cable
		2) Check ICI01sync input (ICI01 #12, 24/#13, 23 wave form)	1) Check signal cable
		3) Check ICI01 video output (ICI1 #15,19,21wave form)	1) Check ICI01 dead
		4) Check IC01 sync output (ICI01 #14, 22 wave form)	1) Check ICI01 dead
	2) Check ICC01 video output (ICC1 #21,24,26 wave form)	1) Check ICC01 CLP input (ICC01 #18)	1) Check ICM01 #31(CLP) 2) Check CNM01 cable
		2) Check ICC01 BLK input (ICC01 #19)	1) Check TH03 #7 wave form 2) Check CNM01 cable 3) Check QC01, QC02
		3) Check ICC01 dead	
	3) Check ICC03 video input (ICC3 #8, 9, 11)	1) Check QC09,10,11,RC08,09, 10,26,27,28,50 51,52	
	4) Check ICC03 video output (ICC3 #1, 3, 5)	1) Check ICC03 VCC(#6, #10) 2) Check ICC03 dead	1) Check 12VB,80V Line
	5) Check R, G, B cathode wave form	1) Check QC03-08 2) Check DC07-09 3) Check ICC#15,16,17	
	6) Check heater voltage	Check DP25	Check 6.3v line

Adjustment Method

1. Caution

Extremely high voltage are present in the area around the FBT and the anode high voltage lead. Do not touch QF01 or its heatsink as high voltage is present on these components.

2. Equipment Required

Digital Voltmeter
Frequency Counter : about 40 Hz to 106KHz
Color Analyzer
Video Signal Generator
High Voltmeter : up to 30 KV

3. Before Adjustment

Verify that the video output level is 0.7 Vpp at 75 ohm termination and the video timings are same as standard timing given in specification. Place the AC power switch to the ON position. Allow the monitor to stabilize thermally for 20 minutes at least before any adjustment about the image parameters. The CRT tube and components of system require time of stabilizing.

4. Adjustment Procedure

4-1 Voltage setting

- 1) High Voltage Setting
 - Video Signal : Black pattern in 106kHz, 1600 mode
 - Set the G2 controls to the minimum position.
 - Measuring Point : PF01
 - Adjustment : VRF01, main board
 - Limits : $156.5 \pm 1V$
- 2) Screen Voltage Setting
 - Video Signal : Back raster pattern in 106kHz, 1600 mode
 - Measuring Point : G2 on the CRT board (use High Voltmeter)
 - Adjustment : Screen VR (lower VR or FBT)
 - Limits : $570 \pm 10V$

4-2 Horizontal Raster Center Setting

- Video Signal : Back raster pattern in 106kHz, 1600 mode
- Measuring Point : SWH01, main board
- Place the Raster in Center of the bezel.

4-3 Rotation setting

- Video signal : Cross Hatch pattern in 106kHz, 1600 mode
- Adjust the tilt of screen by using the Menu Key.

4-4 Color setting

Adhere color Analyzer sensor closely to CRT center.

Video mode : 106kHz, 1600 mode.

1. Color Temperature 9300°K setting
 - Select " 9300 " by using the menu key.
 - 1) Cut-off Setting
 - Video signal : Back Raster Pattern
 - Adjust the brightness to $2.0 \pm 0.5 \text{ cd/m}^2$ by using the Up/down key.
 - Press the Up/down key to get the desired R, G or B Cut-off.
 - Press the Up/down key to limit the x and y color coordinate.
 - Limits : $x=0.283 \pm 0.02$, $y=0.297 \pm 0.02$, $Y=2.0 \pm 0.5 \text{ cd/m}^2$
 - 2) Drive Setting
 - Video signal : 2" square white box
 - Select the "9300" by pressing the menu key.
 - Adjust the brightness go to $80 \sim 100 \text{ cd/m}^2$ by using the Up/down key.
 - Press the Up/down key to get the desired R or B drive.
 - Press the Up/down key to limit the x and y color coordinate.
 - Limits : $x=0.283 \pm 0.02$, $y=0.297 \pm 0.02$, $Y=80 \sim 100 \text{ cd/m}^2$
 - 3) Contrast Setting
 - Adjust the brightness of 2" square white box by using the Up/down key in contrast.
 - Limits : $130 \pm 5 \text{ cd/m}^2$
2. Color Temperature 6500K Setting
 - Select " 6500 " by using the menu key and Up/down key.
 - 1) Cut-off Setting
 - Video signal : Back Raster Pattern
 - Select "Cutoff" by pressing the Up/down key
 - Adjust the brightness to $2.0 \pm 0.5 \text{ cd/m}^2$ by using the Up/down key.
 - Press the Up/down key to get the desired R, G or B Cut-off.
 - Press the Up/down key to limit the x and y color coordinate.
 - Limits : $x=0.313 \pm 0.03$, $y=0.329 \pm 0.03$
 - 2) Drive, contrast Setting
 - The method of Adjust is same to 9300°K.
 - The color coordinate is $x=0.313 \pm 0.03$, $y=0.329 \pm 0.03$, $Y=80 \sim 100 \text{ cd/m}^2$
3. ABL Setting
 - Video signal : Full white
 - Select "ABL" by using the menu Key and Up/down key.
 - Adjust the brightness to $100 \sim 105 \text{ cd/m}^2$ by rotating the Adjust dial.

4-5 Focus

Video Signal : Full "H" character pattern in 106kHz.

Adjust H/V Focus VR on the top of the FBT so that the image of whole screen looks clear.

5. X-Ray Protection Test

- In any signal input condition, short RH03 (main board) by using the JIG.
- At this moment, check out whether raster disappears.
- Remove the JIG.
- After the power switch of the set off and on, check out proper working

6. AGING and Self Test Mode

The monitor has an enhanced level of self-diagnostics.

When the signal cable is removed or signal isn't detected, the monitor is operated to OFF-Mode. If Function Button is pushed on OFF-Mode, the system has the ability to generate an R.G.B test pattern and the following OSD image is displayed on screen.

Note

- 1) Until press information Icon in main menu, the monitor is operated burn-in mode(full white pattern)display.

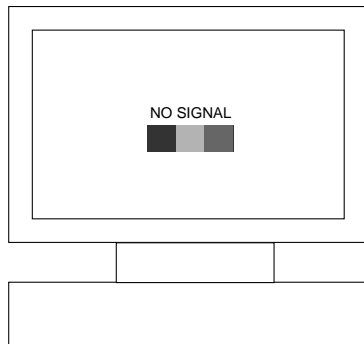

- 2) After press information Icon in main menu, the monitor display random BOX pattern.

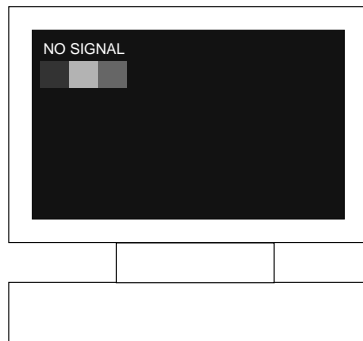

Specification

CRT	SIZE	21"(20" viewable) Diagonal
	Dot Pitch	0.25 mm
	Non-glare	Non-glare, Anti-Static
Input	Signal	R.G.B Analog
	Connector	15 pin D-Type (Basic), BNC (Option)
SYNC	H-F	30KHz ~ 107KHz(Automatic)
	V-F	50 Hz~150 Hz(Automatic)
Video Bandwidth		230 MHz(-3dB)
Display	Area(HXV) Color	380X285 mm (Max. Over Scan)
Resolution		1600X1200 (106kHz/85Hz)
User Controls		H/V Size, H/V Position, Pincushion, Trapezoid, Parallel, Pin Balance, H/V-Moire, Top Corner, Bottom Corner, H/V-Linearity, BNC/D-SUB(Optional), Purity, H/V-Convergence, Language, Rotation, OSD H/V Position, Color Control, Recall, Information, Degauss, Brightness, Contrast
Power Management		As per VESA Standard, Lower than EPA's recommendation
VESA DDC 1/2B		Basic
Compatibility		VESA, 8514/A, XGA, EVGA, MAC II
Power Source		100-240 VAC(Universal Power) 3A 120W(TYP.)
Safety & Regulation	TCO	95,99
	EMC	FCC Class B, CE
	Safety	cULus, CSA, TÜV-GS, DHHS, NEMKO, DEMKO, FIMKO, SEMKO
Temperature	Operating	0 to 40 degree celsius
	Storage	0 to 60 degree celsius
Humidity	Operating	35% to 80% (Non-condensing)
	Storage	5% to 85%
Weight		• Uint : 24.3 Kg • Carton : 29.3Kg
Dimension(WXHXD mm)		500 X 495.3 X 484.5 mm

* Specification is subject to change without notice for performance improvement.

Critical Parts Specification

TDA4841

FEATURES

Concept features

- Full horizontal plus vertical autosync capability
- Extended horizontal frequency range from 15 to 130kHz
- Comprehensive set of I²C-bus driven geometry adjustments and functions, including standby mode
- Very good vertical linearity
- Moire cancellation
- Start-up and switch-off sequence for safe operation of all power components
- X-ray protection
- Power dip recognition
- Flexible switched mode B+ supply function block for feedback and feed forward converter
- Internally stabilized voltage reference
- Drive signal for focus amplifiers with combined horizontal and vertical parabola waveforms
- DC controllable inputs for Extremely High Tension (EHT) compensation
- SDIP 32 package.

Synchronization

- Can handle all sync signals (horizontal, vertical, composite and sync-on-video)
- Output for video clamping (leading/trailing edge selectable by I²C-bus), vertical blanking and protection blanking
- Output for fast unlock status of horizontal synchronization and blanking on grid1 of picture tube.

Horizontal section

- I²C-bus controllable wide range linear picture position, pin unbalance and parallelogram correction via horizontal phase
- Frequency locked loop for smooth catching of horizontal frequency
- Simple frequency preset of f_{min} and f_{max} by external resistors
- Low jitter
- Soft start for horizontal and B+ control drive signals.

Vertical section

- I²C-bus controllable vertical picture size, picture position, linearity (S-correction) and linearity balance
- Output for I²C-bus controllable vertical sawtooth and parabola (for pin unbalance and parallelogram)
- Vertical picture size independent of frequency
- Differential current outputs for DC coupling to vertical booster.
- 50 to 160Hz vertical autosync range.

East-West (EW) section

- I²C-bus controllable output for horizontal pincushion, horizontal size, corner and trapezium correction
- Optional tracking of EW drive waveform with line frequency selectable by I²C-bus.

Focus section

- I²C-bus controllable output for horizontal and vertical parabolas
- Vertical parabola is independent of frequency and tracks with vertical adjustments
- Horizontal parabola independent of frequency
- Adjustable pre-correction of delay in focus output stage.

BLOCK DIAGRAM

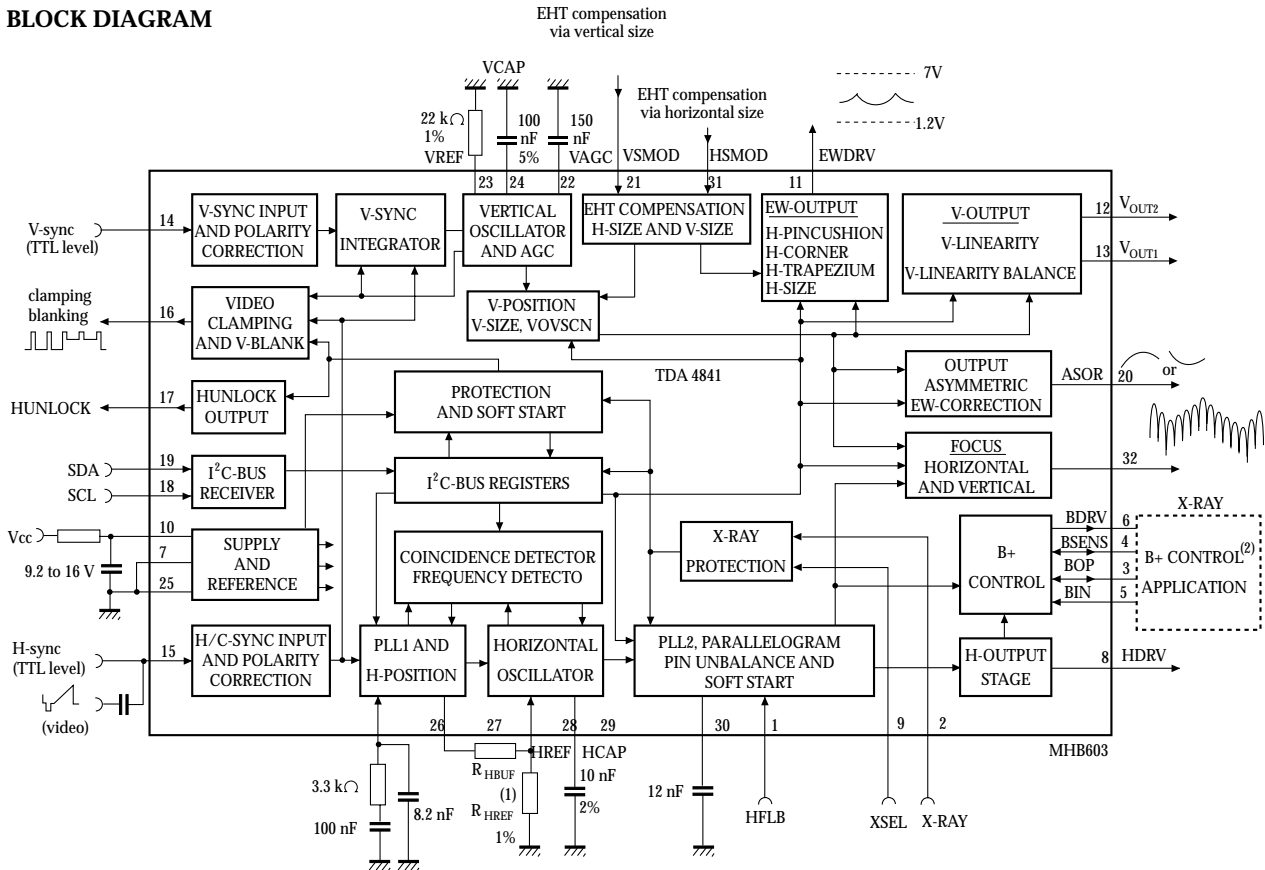

PIN CONFIGURATION

HFLB	□ 1	32	□ FOCUS
XRAY	□ 2	31	□ HSMOD
BOP	□ 3	30	□ HPLL2
BSENS	□ 4	29	□ HCAP
BIN	□ 5	28	□ HREF
BDRV	□ 6	27	□ HBUF
PGND	□ 7	26	□ HPLL1
HDRV	□ 8	25	□ SGND
XSEL	□ 9	24	□ VCAP
Vcc	□ 10	23	□ VREF
EWDRV	□ 11	22	□ VAGC
VOUT2	□ 12	21	□ VSMOD
VOUT1	□ 13	20	□ ASCOR
VSYNC	□ 14	19	□ SDA
HSYNC	□ 15	18	□ SCL
CLBL	□ 16	17	□ HUNLOCK

FUNCTIONAL DESCRIPTION

Horizontal sync separator and polarity correction

HSYNC (pin 15) is the input for horizontal synchronization signals, which can be DC-coupled TTL signals (horizontal or composite sync) and AC-coupled negative-going video sync signals. Video syncs are clamped to 1.28V and sliced at 1.4V. This results in a fixed absolute slicing level of 120mV related to sync top.

For DC-coupled TTL signals the input clamping current is limited. The slicing level for TTL signals is 1.4V.

The separated sync signal (either video or TTL) is integrated on an internal capacitor to detect and normalize the sync polarity.

Normalized horizontal sync pulses are used as input signals for the vertical sync integrator, the PLL1 phase detector and the frequency-locked loop.

Vertical sync integrator.

Normalized composite sync signals from HSYNC are integrated on an internal capacitor in order to extract vertical sync pulses. The integration time is dependent on the horizontal oscillator reference current at HREF (pin 28). The integrator output directly triggers the vertical oscillator.

Vertical sync slicer and polarity correction

Vertical sync signals (TTL) applied to VSYNC (pin 14) are sliced at 1.4V. The output signal of the sync slicer is integrated on an internal capacitor to detect and normalize the sync polarity. The output signals of vertical sync integrator and sync normalizer are disjuncted before they are fed to the vertical oscillator.

Video clamping vertical blanking generator

The video clamping vertical blanking signal at CLBL (pin 16) is a two-level sandcastle pulse which is especially suitable for video ICs such as the TDA488x family, but also for direct applications in video output stages.

The upper level is the video clamping pulse, which is triggered by the horizontal sync pulse. Via I²C-bus Control either the leading or trailing edge can be selected by setting control bit CLAMP. The width of the video clamping pulse is determined by an internal single-shot multivibrator.

The lower level of the sandcastle pulse is the vertical blanking pulse, which is derived directly from the internal oscillator waveform. It is started by the vertical sync and stopped with the start of the vertical scan. This results in optimum vertical blanking. Via I²C-bus Control two different vertical blanking times are accessible by control bit VBLK.

Blanking will be activated continuously, if one of the following conditions is true:

Soft start of horizontal and B+ drive (voltage at HPLL2 (pin 30) pulled down externally or by I²C-bus)

PLL1 is unlocked while frequency-locked loop is in search mode

No horizontal flyback pulses at HFLB (pin 1)

X-Ray protection is activated

Supply voltage at Vcc (pin 10) is low see Fig.22

Via I²C-bus Control horizontal unlock blanking can be switched off by control bit BLKDIS while vertical blanking is maintained.

Frequency-locked loop

The frequency locked loop can lock the horizontal oscillator over a wide frequency range. This is achieved by a combined search and PLL operation. The frequency range is preset by two external resistors and the recommended maximum

$$\text{ratio is } \frac{f_{\max}}{f_{\min}} = \frac{6.5}{1}$$

This can, for instance, be a range from 15.625 to 90kHz with all tolerances included. Without a horizontal sync signal the oscillator will be free-running at f_{mix} . Any change of sync conditions is detected by the internal coincidence detector. A deviation of more than 4% between horizontal sync and oscillator frequency will switch the horizontal section into search mode. This means that PLL1 control currents are switched off immediately. The internal frequency detector then starts tuning the oscillator. Very small DC currents at HPLL1 (pin26) are used to perform this tuning with a well defined change rate. When coincidence between horizontal sync and oscillator frequency is detected, the search mode is first replaced by a soft-lock mode which lasts for the first part of the next vertical period.

The soft-lock mode is then replaced by a normal PLL operation. This operation ensures a smooth tuning and avoids fast changes of horizontal frequency during catching.

In this concept it is not allowed to load HPLL1.

The frequency dependent voltage at this pin is fed internally to HBUF (pin27) via a sample-and-hold and buffer stage. The sample-and-hold stage removes all disturbances caused by horizontal sync or composite vertical sync from the buffered voltage. An external resistor connected between pins HBUF and HREF defines the frequency range.

Out-of-lock indication (pin HUNLOCK)

Pin hunlock is floating during search mode or if a protection condition is true.

All this can be detected by the microcontroller if a pull-up resistor is connected to its own supply voltage.

For an additional fast vertical blanking at grid 1 of the picture tube, a signal referenced to ground is available at this output. Also the continuous protection blanking (see Section "Video clamping/vertical blanking generator") is available at this pin. Via I2c-bus control, the control bit Blkdis can switch off horizontal unlock blanking while vertical blanking is maintained.

Horizontal oscillator

The horizontal oscillator is of the relaxation type and requires a capacitor of 10 nF at HCAP (pin29). For optimum jitter performance the value of 10nF must not be changed.

The minimum oscillator frequency is determined by a resistor connected between pin HREF and ground. A resistor connected between pins HREF and HBUF defines the frequency range.

The reference current at pin HREF also defines the integration time constant the vertical sync integration.

KA2142

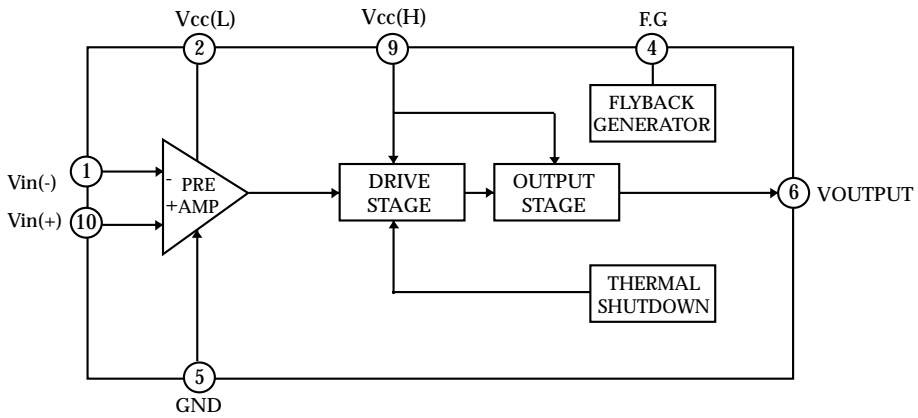
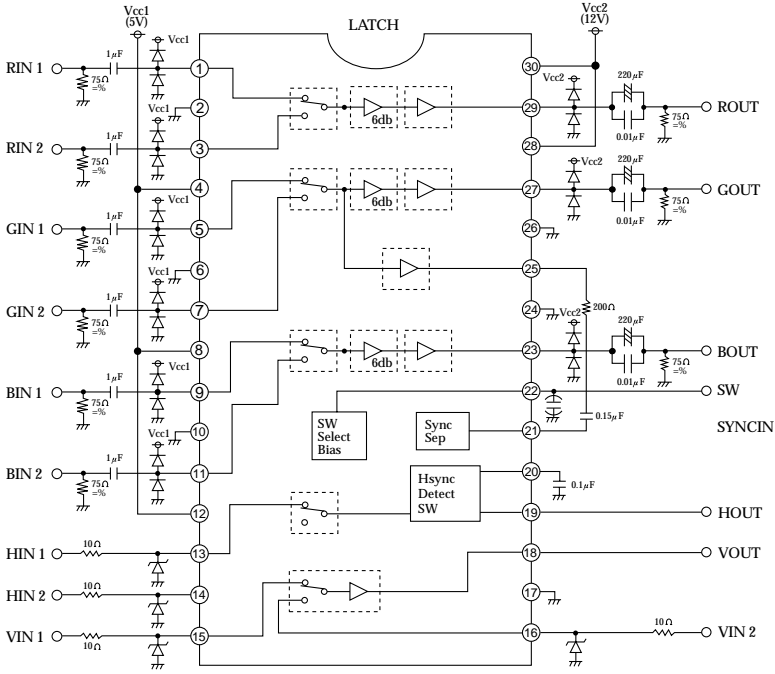

Table1. Pin Configurations

Pin No	Symbol	I / O	Configurations
1	Vin (-)	I	Inverting Input
2	Vcc (L)	I	Supply Voltage
3	-	-	N.C
4	F . G	O	Flyback Generator
5	GND	-	Ground
6	VD	O	Output
7	-	-	N.C
8	-	-	N.C
9	Vcc (H)	I	Output Stage Voltage
10	Vin (+)	I	Non-Inverting Input

BA7657S

BNC (OPTION)-BLOCK DIAGRAM



BLOCK DIAGRAM

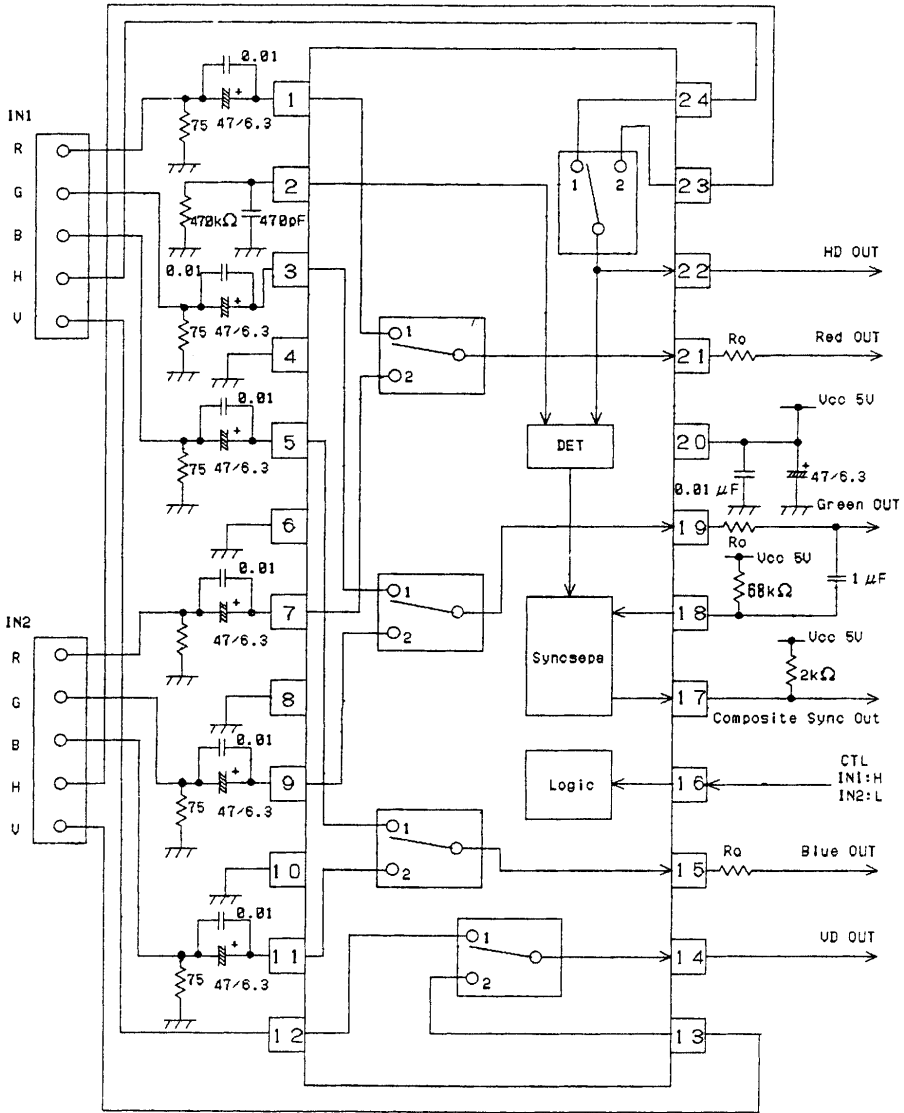

PINNING

No.	DESCRIPTION	No.	DESCRIPTION
1	B Input 1	13	V Input 2
2	GND	14	V Output
3	G Input 1	15	R Output
4	GND	16	BNC/D-SUB
5	R Input 1	17	COMPOSITE SYNC OUTPUT
6	GND	18	SOG
7	B Input 2	19	G Output
8	GND	20	VDD
9	G Input 2	21	B Output
10	GND	22	H Output
11	R Input 2	23	H Input 2
12	V Input 1	24	H Input 1

LM2413

Monolithic Triple 3 nsec CRT Driver

General Description

The LM2413 is an integrated high voltage CRT driver circuit designed for use in high resolution color monitor applications. The IC contains three high input impedance, wide band amplifiers which directly drive the RGB cathodes of a CRT. Each channel has its gain internally set to -14 and can drive CRT capacitive loads as well as resistive loads presented by other applications, limited only by the package's power dissipation. The IC is packaged in an industry standard 11 lead TO-220 molded plastic power package. See thermal considerations on page 6.

SCHEMATIC and CONNECTION DIAGRAMS

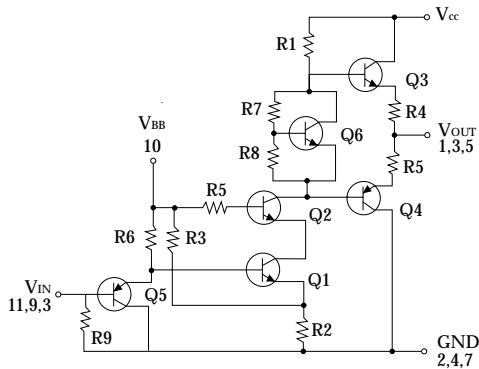

Simplified Schematic Diagram (One Channel)

Features

- Rise/fall times typically 3.0/3.5ns with 8pF load at 40 Vpp
- Well matched with Lm2202 video preamps
- Output swing capability: 50 Vpp for Vcc=80 volts
- 1 to 5V input range
- Stable with 0-20pF capacitive loads and inductive peaking networks
- Convenient TO-220 staggered lead package style
- Standard LM24XX Family pinout which is designed for easy PCB layout

Applications

- CRT driver for color monitors with display resolutions up to 1600x1200
- Pixel clock frequency up to 180MHz

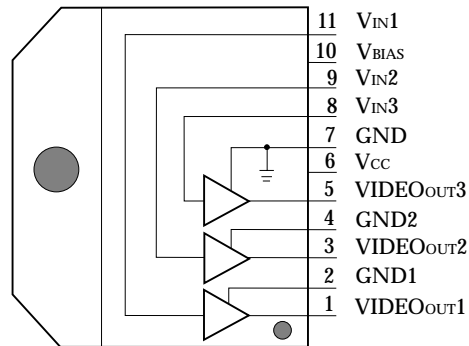

Top View

STR-F6654

BLOCK DIAGRAM

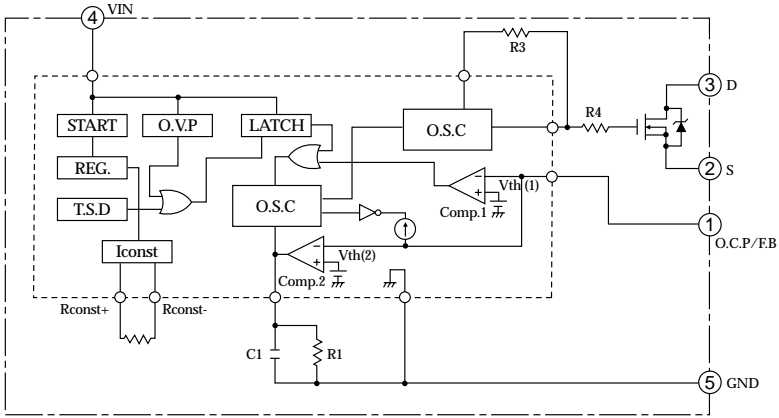

Function of Terminal

Terminal No.	Symbols	Description	Functions
1	O.C.P./F.B	Overcurrent/Feedback terminal	Input of overcurrent detection signal and constant voltage control signal
2	S	Source terminal	MOS FET source
3	D	Drain terminal	MOS FET drain
4	VIN	Power supply terminal	Input of power supply for control circuit
5	GND	Ground terminal	Ground

Other Function

Symbols	Functions
O.V.P	Built-in overvoltage protection circuit
T.S.D	Built-in thermal shutdown circuit

Internal Constants

R1	T _{OFF} Adjustment Trimming Resistor	R4	10 Ω
R2	I _{const} Adjustment Trimming Resistor	C1	4700pF
R3	150 Ω		

WT62PI

PIN CONNECTIONS

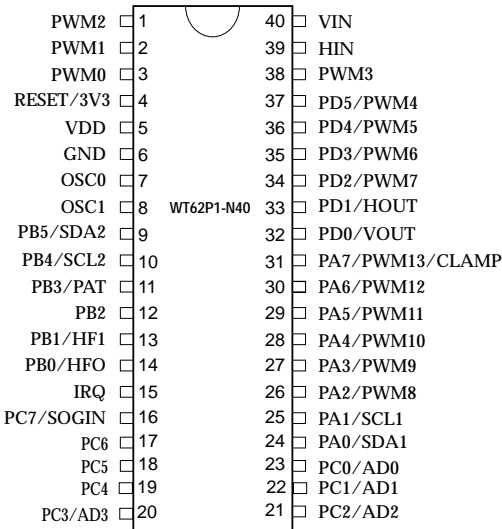

PIN DESCRIPTION

1	PURITY	21	UNLOCK
2	V-CONVERGENCE	22	ABL
3	H-CONVERGENCE	23	Key-in
4	Reset	24	SDA1
5	+5V	25	SCL1
6	GND	26	CS5
7	OSC0	27	CS4
8	OSC1	28	CS3
9	SUS/Stand-by	29	CS2
10	off	30	CS1
11	H-mute	31	Clamp
12	Direction	32	V-out
13	Degauss	33	H-out
14	BNC/D-Sub	34	sub size
15	ENCODER	35	Brt
16	LED1	36	H-Lin
17	LED2	37	TILT
18	-	38	ACL
19	SCL	39	H-Sync
20	SDA	40	V-Sync

24LC08

8K 2.5V CMOS Serial EEPROMs

FEATURES

- Single supply with operation down to 2.5V
- Low power CMOS technology
 - 1 mA active current typical
 - 10µA standby current typical at 5.5V
 - 5 µA standby current typical at 3.0V
- Organized as two or fore blocks of 256 bytes (2X256X8) and (4X256X8)
- Two wire serial interface bus, 1²CTM
- Schmitt tigger, filtered inputs for noise suppression
- Output slope control to eliminate ground bounce
- 100kHz (2.5V) and 400kHz (5V) compatibility
- Self-timed write cycle (including auto-erase)
- Page-write buffer for up to 16 bytes
- 3.5 ms typical write cycle time for page-write
- Hardware write cycle time for page-write
- Can be operated as a serial ROM
- Factory programming (OTP) available
- ESD protection > 3,000V
- 1,000,000 ERASE/WRITE cycles (typical)
- Data retention > 100 years
- 8-pin DIP, 8-lead or 14-lead SOIC packages
- Available for extended temperature ranges
 - Commercial : 0°C to +70°C
 - Industrial : -40°C to +85°C

DESCRIPTION

The Microchip Technology Inc. 24LC04B/08B is a 4K-or 8K-bit Electrically Erasable PROM. The device is organized as two or four blocks of 256x8 bit memory with a two wire serial interface. Low voltage design permits operation down to 2.5 volts with standby and active currents of only 5µA and 1mA respectively. The 24LC04B/08B also has a page-write capability for up to 16 bytes of data. The 24LC04B/08B is available in the standard 8-pin DIP and both 8-lead and 14-lead surface mount SOIC packages.

BLOCK DIAGRAM

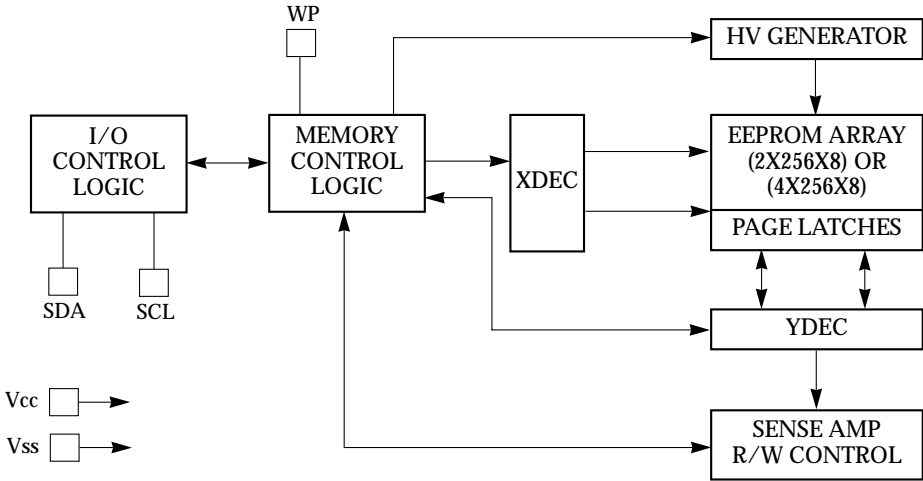

PIN CONFIGURATION

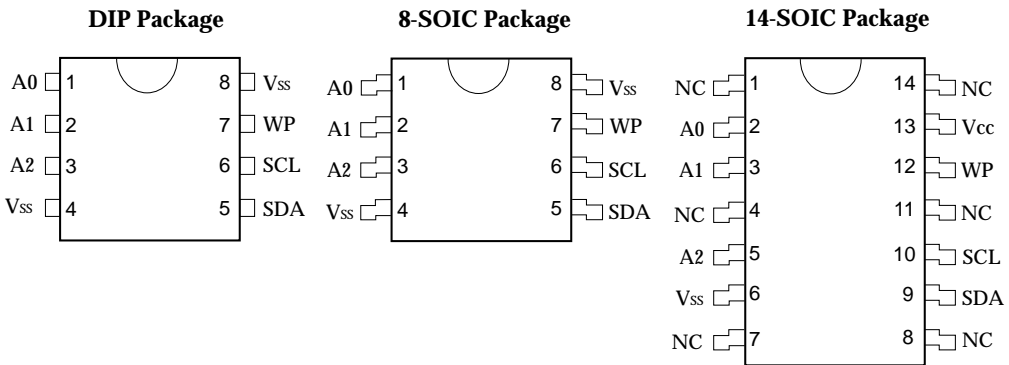

PC is a trademark of Philips Corporation

KA3842B/43B

CURRENT MODE PWM CONTROLLER

- OPTIMIZED FOR OFF-LINE AND DC TO DC CONVERTERS
- LOW START-UP CURRENT (<1mA)
- AUTOMATIC aFEED FORWARD COMPENSATION
- PULSE-BY-PULSE CURRENT LIMITING
- ENHANCED LOAD RESPONSE CHARACTERISTICS
- DOUBLE PULSE SUPPRESSION
- HIGH CURRENT TOTEM POLE OUTPUT
- INTERNALLY TRIMMED BANDGAP REFERENCE
- 500kHz OPERATION
- LOW R_o ERROR AMP

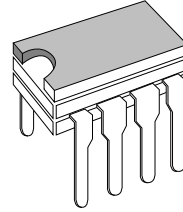

Minidip

PIN CONNECTIONS

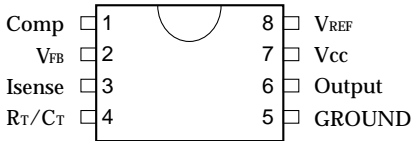

BLOCK DIAGRAM

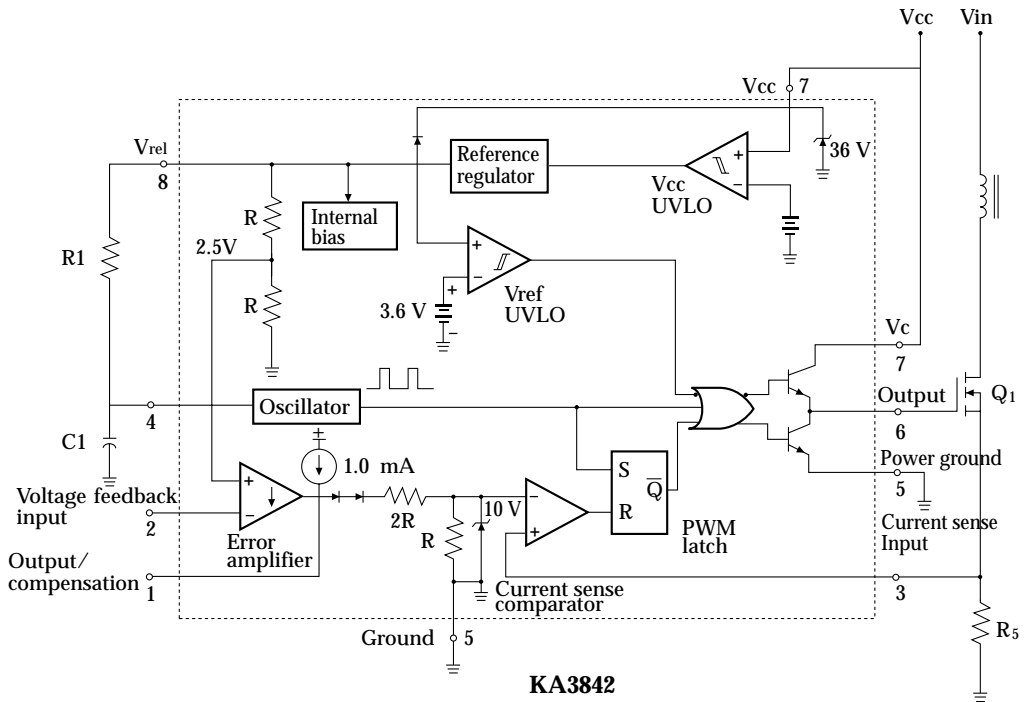

LM358

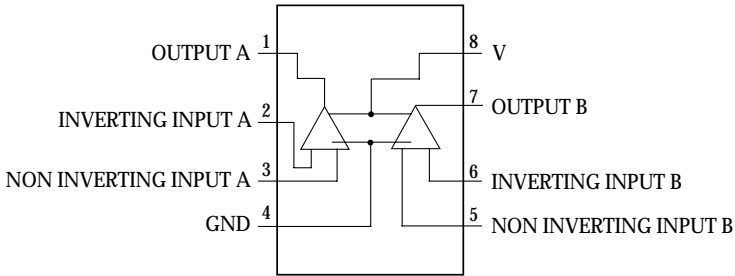

Voltage Regulator ICs

Type No.	Function	Typ Vo(V)	Max.			Package
			Io(A)	Vin(V)	Pd(W)	
KIA7805P/PI	1.0A 3-Terminal Regulator	5	1.0	35	20.8	 TO-220AB
KIA7806P/PI		6				
KIA7808P/PI		8				
KIA7809P/PI		9				
KIA7810P/PI		10				
KIA7812P/PI		12				
KIA7815P/PI		15				
KIA7818P/PI		18				
KIA7820P/PI		20	40			
KIA7824P/PI		24				
						 I C O

MTV021

FEATURES

- Horizontal SYNC input up to 130KHz.
- On-chip PLL circuitry up to 96 MHz.
- Programmable horizontal resolutions up to 1524 dots per display row.
- Full-screen display consists of 15(rows)by 30(columns) characters.
- 12 X 18 dot matrices per character.
- Total of 272 characters and graphic fonts, including 256 standard and 16 multi-color mask ROM Fonts.
- 8 color-selectable maximum per display character.
- 7 color-selectable maximum for character background.
- Double character height and/or width control.
- Programmable positioning for display screen center.
- Row to row spacing register to manipulate the constant display height.
- 4 Programmable background windows with multi-level operation and shadowing on window effect.
- Software clears bit for full-screen erasing.
- Half tone and fast blanking output.
- Fade-in/fade-out effect.
- 8-channel/8-bit PWM D/A converter output.
- Compatible with SPI bus or I2C interface with slave address 7AH(slave address is mask option).
- 16-pin, 20-pin or 24-pin PDIP package.

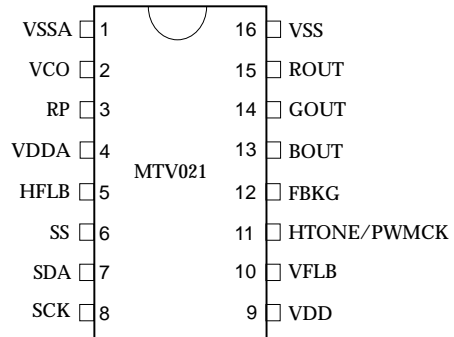

LM431

PROGRAMMABLE PRECISION REFERENCES SILICON MONOLITHIC INTEGRATED CIRCUIT

- Programmable Output Voltage to 36V
- Voltage Reference Tolerance : $\pm 0.4\%$, Typ @ 25°C (TL431B)
- Low Dynamic Output Impedance, 0.22 Typical
- Sink Current Capability of 1.0mA to 100mA
- Equivalent Full-Range Temperature coefficient of 50 ppm/°C Typical
- Temperature Compensated for Operation over full Rated Operating Temperature Range.
- Low Output Noise Voltage.

SYMBOL

FUNCTIONAL BLOCK DIAGRAM

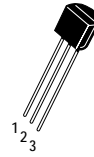
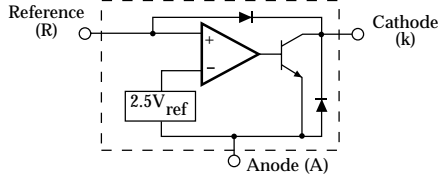
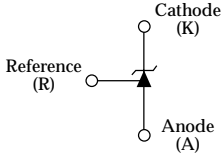

Pin 1. Reference
2. Anode
3. Cathode

INTERNAL SCHEMATIC
Component values are nominal

LP SUFFIX
CASE 29
(TO-92)

Power Transistor

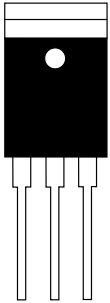

RATING	SYMBOL	2SC5411	UNIT
Base Breakdown Voltage	VCBO	1500	Vdc
Emitter Sustaining Voltage	VCEO(SUS)	600	Vdc
Current-Continuous -Pulsed(1)	IC ICP	14 28	Adc
Current-Continuous	IB	7	Adc

Damper Diode

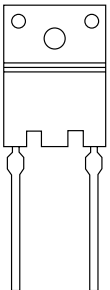

RATING	SYMBOL	DTV32F	UNIT
Drain-Source Voltage	VDSS	1500	
Drain Current	ID	15	A
D-current(pulsed)	IDM	75	A

TRANSISTORS

Type No.	MAX. RATINGS			$V_{CE(SET)}$		Max	No			Package
	V_{CEO} (V)	I_C (mA)	P_C (mW)	(V)	I_C (mA)	I_B (mA)	1	2	3	
KSC945CY	50	150	250	0.15	100	10	E	C	B	TO-92
KS733CY	-50	-150	250	-0.3	-100	-10	E	B	C	TO-92
KSP45	350	300	1.5W	0.5	10	1	E	B	C	TO-92
KSA928AY	-30	-2A	1W	-2.0	-1.5A	-30	E	C	B	TO-92
KTA200Y	-50	-500	625	-0.25	-100	-10-30	E	C	B	TO-92
KSA1013AY	-160	-1A	900	-1.5	-500	-50	E	C	B	TO-92
KSA2328AY	30	2A	1W	2.0	1.5A	3.0	E	C	B	TO-92
KRC102M	50	100	400	-0.3	-100	-0.88	E	C	B	TO-92
KTA1266	-50	-150	625	-0.3	-100	-10	E	C	B	TO-92
KTC3200	120	100	625	0.3	10	1	E	C	B	TO-92
KTC3228Y	160	1A	1W	1.5	500	50	E	B	C	TO-92
KSC5042F	900	100	6W	5	20	4	E	C	B	TO-220
BD135	45	2A	8W	0.5	500	50	E	C	B	TO-92
2N5770	15	50	350	0.4	10	1.0	E	B	C	TO-126
KSP92	-300	-500	625	-0.5		-0.25	E	B	C	TO-92
KSP42	300	500	625	-0.5	20	2	E	B	C	(5011)

FET	V_{DSS} (V)	I_{DSS}	PD	R_{DSS} (ohm)	V_{GS}	1	2	3	PACKAGE
2N7000	60	200mA	400mW	5	$\pm 40V$	S	G	D	TO-92
SFP9644	-250	-8.6A	123W	0.8	-4.0	G	D	S	TO-220
2SK2134	200	13A	70W	0.3	4.0	G	D	S	TO-220
IRF630A	200	9A	72W	0.4	4.0	G	D	S	TO-220
IRFS630A	200	6.5A	38W	0.4	4.0	G	D	S	TO-220

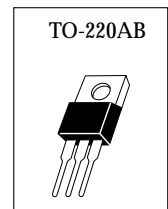
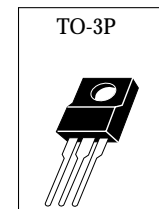
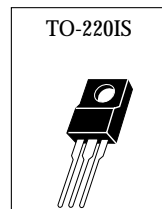
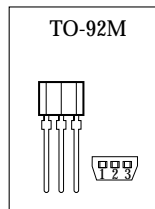
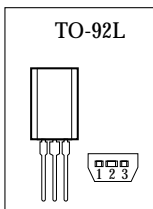
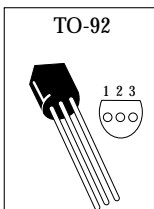

MAIN

NUM.	LOCATION	PART NUMBER	DESCRIPTION	REMARK
1	BD01	3540200058	BD-FER,BFS3550	
2	BDP01	3102000195	DI-BRI,RBV-606 LEAD	
3	BH01	3540200058	BD-FER,BFS3550	
4	BH02	E42019058210	COIL,PEAKING 10 UH AXIAL	
5	BH03	3540200059	BD-FER,BFS3580	
6	BH05	3540200058	BD-FER,BFS3550	
7	BH06	3540200058	BD-FER,BFS3550	
8	BP01	3540200059	BD-FER,BFS3580	
9	BP02	375300002401	WIRE-NS-S43MM TAP. SDA 1/	
10	BP03	3540200059	BD-FER,BFS3580	
11	BP04	3540200058	BD-FER,BFS3550	
12	BP05	3540200059	BD-FER,BFS3580	
13	BP06	3540200058	BD-FER,BFS3550	
14	CCP1	2131040020	CAP-MULT,0.1UF 50V Z AXI	
15	CCP2	CE04BT1C470M	CAP-EL,SMS 16V 47UF M	
16	CCP3	2131040020	CAP-MULT,0.1UF 50V Z AXI	
17	CCP4	CE04BT1C470M	CAP-EL,SMS 16V 47UF M	
18	CCP5	CE04BT1C470M	CAP-EL,SMS 16V 47UF M	
19	CCP6	2131040020	CAP-MULT,0.1UF 50V Z AXI	
20	CF01	CQ92BT2A103J	CAP-PE,100V 0.01UF J	
21	CF02	2171520013	CAP-P-F,1500PF 250V J RAD	
22	CF03	CC45CT1H331J	CAP-CD,50V 330PF J	
23	CF04	CQ92BT2A272J	CAP-PE,100V 0.0027UF J	
24	CF05	2178210005	CAP-P-F,820PF 100V J RAD	
25	CF06	CQ92BT2A472J	CAP-PE,100V 0.0047UF J	
26	CF07	CE04BT1C101M	CAP-EL,SMS 16V 100UF M	
27	CF08	CQ92BT2A332J	CAP-PE,100V 3300PF J	
28	CF09	2178210006	CAP-P-F,820PF 1KV J RAD	
29	CF11	CQ92BT2A473J	CAP-PE,100V 0.047UF J	
30	CF12	CE04BT1C470M	CAP-EL,SMS 16V 47UF M	
31	CF13	CE04BT1C220M	CAP-EL,SMS 16V 22UF M	
32	CF15	2002290042	CAP-AL,2.2UF 50V M 5*11 N	
33	CF16	CQ92BT2A683J	CAP-PE,100V 0.068UF J	
34	CF17	CE04BT1H010M	CAP-EL,SMS 50V 1UF M	
35	CF18	2001090057	CAP-AL,1UF 200V M 6.3*11	
36	CF19	200100007501	CAP-AL,10UF 350V M 10*20	
37	CF20	CQ92BT2A104J	CAP-PE,100V 0.1UF J	
38	CF21	2141040020	CAP-M-P,0.1UF 250V J RAD	
39	CF22	CC45CT1H101J	CAP-CD,50V 100 PF J TAP	
40	CF24	CQ92BT2A104J	CAP-PE,100V 0.1UF J	
41	CF25	CQ92BT2A182J	CAP-PE,100V 1800PF J	
42	CF26	2131040020	CAP-MULT,0.1UF 50V Z AXI	
43	CF27	2102200010	CAP-CER,22PF 500V J COG	

NUM.	LOCATION	PART NUMBER	DESCRIPTION	REMARK
44	CF28	2102200010	CAP-CER,22PF 500V J COG	
45	CF29	CE04BT1H2R2M	CAP-EL,SMS 50V 2.2UF M	
46	CF31	CE04BT1C470M	CAP-EL,SMS 16V 47UF M	
47	CF32	2001010097	CAP-AL,100UF 160V M 13*25	
48	CH01	CE04BT1C101M	CAP-EL,SMS 16V 100UF M	
49	CH02	CE04BT1C100M	CAP-EL,SMS 16V 10UF M TAP	
50	CH03	CK45BT1H681K	CAP-CD,50V 680PF K	
51	CH04	CE04BT1H2R2M	CAP-EL,SMS 50V 2.2UF M	
52	CH05	CQ93PT2A152J	CAP-PP,100V 1500PF J TAP	
53	CH06	CE04BT1C101M	CAP-EL,SMS 16V 100UF M	
54	CH08	CE04BT1C100M	CAP-EL,SMS 16V 10UF M TAP	
55	CH09	CQ92BT2A154J	CAP-PE,100V 0.15UF J	
56	CH10	CQ92BT2A104J	CAP-PE,100V 0.1UF J	
57	CH11	CQ92BT2A822J	CAP-PE,100V 0.0082UF J	
58	CH12	CE04BT1HR47M	CAP-EL,SMS 50V 0.47UF M	
59	CH13	E42007019070	CAP-PP/PE,100V 0.01UF J	
60	CH14	E42007019050	CAP-PP/PE,100V 0.0047UF J	
61	CH15	2143330004	CAP-M-P,0.033UF 250V J PE	
62	CH17	2003300031	CAP-AL,33UF 250V M 12.5*2	
63	CH18	2102210019	CAP-CER,220PF 500V J COG	
64	CH19	2174920003	CAP-P-F,4900PF 2.5KV J FO	
65	CH20	2001010116	CAP-AL,100UF 25V M 10*20	
66	CH21	CE04BT1E100M	CAP-EL,SMS 25V 10UF M	
67	CH22	CE04BT1C470M	CAP-EL,SMS 16V 47UF M	
68	CH26	CF93BT1J224J	CAP-MPE,63V 0.22UF J	
69	CH27	CE04BT1E100M	CAP-EL,SMS 25V 10UF M	
70	CH28	E42007019030	CAP-PP/PE,100V 0.0022UF J	
71	CH29	CQ92BT2A473J	CAP-PE,100V 0.047UF J	
72	CH30	CE04BT1H010M	CAP-EL,SMS 50V 1UF M	
73	CH31	2141550002	CAP-M-P,1.5UF 250V J FOR	
74	CH32	2001000078	CAP-AL,10UF 250V M 13*25	
75	CH33	CE04BT1H010M	CAP-EL,SMS 50V 1UF M	
76	CH34	2148240004	CAP-M-P,0.82UF 250V J PP	
77	CH35	CE04BT1H010M	CAP-EL,SMS 50V 1UF M	
78	CH36	2172740001	CAP-PF,0.27UF 250V J FOR	
79	CH37	CE04BT1H010M	CAP-EL,SMS 50V 1UF M	
80	CH38	214104001703	CAP-M-P,0.1UF 250V J 7.5	
81	CH39	CE04BT1H010M	CAP-EL,SMS 50V 1UF M	
82	CH40	214104001703	CAP-M-P,0.1UF 250V J 7.5	
83	CH41	2172440001	CAP-P-F,0.24UF 250V J RAD	
84	CH44	2102230017	CAP-CER,0.022UF 1KV J Z4U	
85	CH45	CE04IT1E470M	CAP-EL,KME 25V 47UF M	
86	CM02	CE04BT1HR47M	CAP-EL,SMS 50V 0.47UF M	
87	CM03	CE04BT1C470M	CAP-EL,SMS 16V 47UF M	

NUM.	LOCATION	PART NUMBER	DESCRIPTION	REMARK
88	CM04	CC45CT1H220J	CAP-CD,50V 22PF J	
89	CM05	CC45CT1H220J	CAP-CD,50V 22PF J	
90	CM06	CQ92BT2A103J	CAP-PE,100V 0.01UF J	
91	CM07	2131040020	CAP-MULT,0.1UF 50V Z AXI	
92	CM08	2131040020	CAP-MULT,0.1UF 50V Z AXI	
93	CM09	2131040020	CAP-MULT,0.1UF 50V Z AXI	
94	CM10	2131040020	CAP-MULT,0.1UF 50V Z AXI	
95	CM11	CE04BT1HR47M	CAP-EL,SMS 50V 0.47UF M	
96	CNB01	3720101397	CONN-M,SMW250-03 3	
97	CNB02	3720101397	CONN-M,SMW250-03 3	
98	CNB02	3725005176	CONN-A,3P WIRE 300MM F910	
99	CND02	372110115401	CONN-F,LFW250-09	
100	CNH01	372010105301	CONN-M,POST 1P DEGT235 14	
101	CNM01	3720101916	CONN-M,SMW200-14 14	
102	CNM01	372500490701	CONN-A,14P FLAT 350MM G91	
103	CNP01	372010105301	CONN-M,POST 1P DEGT235 14	
104	CNP03	3720101397	CONN-M,SMW250-03 3	
105	CNP03	3725005171	CONN-A,3P CBL 250MM F910	
106	CNR01	3720101467	CONN-M,LEOCO 2421P03V000	
107	CP01	E4200700910A	CAP-X,250VAC 0.33UF M TAP	
108	CP02	E42007027050	CAP-CD,Y2 2200PF M TAP	
109	CP03	E42007027050	CAP-CD,Y2 2200PF M TAP	
110	CP04	2001510008	CAP-AL,150UF 450V M 25.4*	
111	CP05	CK45BF2H103K	CAP-CD,500V 0.01UF K	
112	CP06	210472001501	CAP-CER,Y1 4700PF M NO-CU	
113	CP07	CE04BT2C220M	CAP-EL,SMS 160V 22UF M	
114	CP08	CE04BT1H101M	CAP-EL,SMS 50V 100UF M	
115	CP09	CQ92BT2A104J	CAP-PE,100V 0.1UF J	
116	CP10	E42007019250	CAP-PP/PE,100V 560PF J	
117	CP11	2004700096	CAP-AL,47UF 35V M 6.3*11	
118	CP12	2131040020	CAP-MULT,0.1UF 50V Z AXI	
119	CP13	CE04BT1H2R2M	CAP-EL,SMS 50V 2.2UF M	
120	CP14	E4200700910A	CAP-X,250VAC 0.33UF M TAP	
121	CP51	CK45BT3A101K	CAP-CD,1KV 100PF 10%	
122	CP52	2004700095	CAP-AL,47UF 250V M 13*25	
123	CP53	CE04BT1C102M	CAP-EL,SMS 16V 1000UF M	
124	CP54	CE04BT2A470M	CAP-EL,SMS 100V 47UF M	
125	CP55	CE04BT2C220M	CAP-EL,SMS 160V 22UF M	
126	CP56	CE04BT1E221M	CAP-EL,SMS 25V 220UF M	
127	CP57	2004710043	CAP-AL,470UF 16V M 10*12.	
128	CP58	CE04BT1C221M	CAP-EL,SMS 16V 220UF M	
129	CP59	2004710043	CAP-AL,470UF 16V M 10*12.	
130	CP60	CE04BT1C101M	CAP-EL,SMS 16V 100UF M	
131	CP61	CE04BT1E331M	CAP-EL,SMS 25V 330UF M	

NUM.	LOCATION	PART NUMBER	DESCRIPTION	REMARK
132	CP63	CE04BT1E222M	CAP-EL,SMS 25V 2200UF M	
133	CP64	CQ92BT2A223J	CAP-PE,100V 0.022UF J	
134	CP65	CE04BT1E101M	CAP-EL,SMS 25V 100UF M	
135	CP67	CE04BT1C470M	CAP-EL,SMS 16V 47UF M	
136	CP68	CE04BT1C101M	CAP-EL,SMS 16V 100UF M	
137	CP70	CQ92BT2A473J	CAP-PE,100V 0.047UF J	
138	CR01	CE04BT1E470M	CAP-EL,SMS 25V 47UF M	
139	CV01	CQ92BT2A472J	CAP-PE,100V 0.0047UF J	
140	CV02	CE04BT1C471M	CAP-EL,SMS 16V 470UF M	
141	CV03	2002210091	CAP-AL,220UF 35V M 10*13	
142	CV04	CF93BT1J105J	CAP-MPE,63V 1UF J	
143	CV05	2004710043	CAP-AL,470UF 16V M 10*12.	
144	CV06	CQ92BT2A103J	CAP-PE,100V 0.01UF J	
145	CV07	CQ92BT2A273J	CAP-PE,100V 0.027UF J	
146	DF01	DT1N4148	DIODE,1N4148 TAPING	
147	DF02	3100500181	DI-SW,GUR460L-5703 LEAD	
148	DF03	DTUF4007	DIODE,UF4007	
149	DF04	DT1N4148	DIODE,1N4148 TAPING	
150	DF05	DT1N4148	DIODE,1N4148 TAPING	
151	DF06	DT1N4148	DIODE,1N4148 TAPING	
152	DF07	DT1N4148	DIODE,1N4148 TAPING	
153	DF08	DT1N4148	DIODE,1N4148 TAPING	
154	DF09	DT1N4936	DIODE,400V 1.0A 1N4936	
155	DF10	DT1N4004	DIODE,400V 1.0A TAP	
156	DF11	DT1N4004	DIODE,400V 1.0A TAP	
157	DF12	DT1N4148	DIODE,1N4148 TAPING	
158	DF13	DTUZ-12BSB	DIODE,ZENER UZ-12BSB TAP	
159	DF14	DT1N4148	DIODE,1N4148 TAPING	
160	DF15	DT1N4148	DIODE,1N4148 TAPING	
161	DF16	DT1N4148	DIODE,1N4148 TAPING	
162	DF17	DT1N4148	DIODE,1N4148 TAPING	
163	DF18	DT1N4148	DIODE,1N4148 TAPING	
164	DF19	DTRGP02-16	DIODE, RGP02-16	
165	DF21	DTUZ-6.8BSB	DIODE,ZENER UZ-6.8BSB TAP	
166	DF22	DTRGP02-16	DIODE, RGP02-16	
167	DH01	DT1N4148	DIODE,1N4148 TAPING	
168	DH02	DTUZ-12BSB	DIODE,ZENER UZ-12BSB TAP	
169	DH03	3100500163	DI-SW, RG4 LF-L1(015-206)	
170	DH04	3102000217	DI-REC, DTV32F LEAD	
171	DH05	3104100134	DI-SHOT, SB350L-57 LEAD	
172	DH06	DT1N4148	DIODE,1N4148 TAPING	
173	DH07	DT1N4007	DIODE,1000V 1.0A TAP	
174	DH08	DT1N4007	DIODE,1000V 1.0A TAP	
175	DH09	DT1N4004	DIODE,400V 1.0A TAP	

NUM.	LOCATION	PART NUMBER	DESCRIPTION	REMARK
176	DH10	DTUZ-12BSB	DIODE,ZENER UZ-12BSB TAP	
177	DH11	DT1N4148	DIODE,1N4148 TAPING	
178	DH12	DT1N4148	DIODE,1N4148 TAPING	
179	DH13	DT1N4936	DIODE,400V 1.0A 1N4936	
180	DH14	3101000347	DI-ZN,BZX55-C62 LEAD	
181	DH15	DT1N4936	DIODE,400V 1.0A 1N4936	
182	DH17	DTUF4007	DIODE,UF4007	
183	DH18	DT1N4148	DIODE,1N4148 TAPING	
184	DH19	DTUZ-6.2BSB	DIODE,ZENER UZ-6.2BSB T	
185	DH20	DTUZ-6.2BSB	DIODE,ZENER UZ-6.2BSB T	
186	DP01	DTUF4007	DIODE,UF4007	
187	DP02	DT1N4937	DIODE,1N4937 TAPING	
188	DP03	DT1N4936	DIODE,400V 1.0A 1N4936	
189	DP04	DTUZ-13B	DIODE,ZENER UZ-13B	
190	DP05	DT1N4148	DIODE,1N4148 TAPING	
191	DP06	DT1N4148	DIODE,1N4148 TAPING	
192	DP07	DT1N4148	DIODE,1N4148 TAPING	
193	DP09	DT1N4148	DIODE,1N4148 TAPING	
194	DP10	DT1N4936	DIODE,400V 1.0A 1N4936	
195	DP21	3100500149	DI-SW,RG4C LF-K2(015-202)	
196	DP22	3100500087	DI-SW,S2L60-4004P15 LEAD	
197	DP23	3100500087	DI-SW,S2L60-4004P15 LEAD	
198	DP24	DTUF4004	DIODE,UF4004	
199	DP25	3100500178	DI-SW,UF1G-5705 LEAD	
200	DP26	DT1N4936	DIODE,400V 1.0A 1N4936	
201	DP27	3100500163	DI-SW,RG4 LF-L1(015-206)	
202	DP28	3100500163	DI-SW,RG4 LF-L1(015-206)	
203	DP29	DTISS81	DIODE,SWITCHING ISS81	
204	DP30	DTUZ-13B	DIODE,ZENER UZ-13B	
205	DV01	DTUF4002	DIODE,UF4002	
206	FP01	E42076013010	FUSE CLIP,TAPING	
207	FP01	3628000024	CLP-FUSE,HBC 50CT 250V 4A	
208	HCON	3720101837	CONN-M,BH 2B-PH 2	
209	ICF01	UKA3843	IC,KA3843 DIP CONTROLLER	
210	ICF02	ULM358N	IC,OP-AMP LM358N	
211	ICH01	3200001408	IC-LIN,TDA4841PS SDIP 32P	
212	ICM01	3205001327	IC-U,WT62P1-N40 DIP MTP	
213	ICM02	3203000819	IC-MEMO,S524C80D81-DCB0	
214	ICP01	3200001258	IC-LIN,STRF6654A(LF1352)	
215	ICP01H	6124029211	H-SINK PWR FET A,G210	
216	ICP02	ULM431ACZT	ADJ SHUNT REG LM431 TAP	
217	ICP03	ULM7805CT	IC,VOL REGULATOR,LM7805CT	
218	ICP04	ULM7812CT	IC,VOL REGULATOR,LM7812CT	
219	ICP04H	6124031302	H-SINK TR C,HT-7770C	

NUM.	LOCATION	PART NUMBER	DESCRIPTION	REMARK
220	ICP06	3331100041	P-COUPLER,TLP621(D4,T)	
221	ICV01	3200001409	IC-LIN,KA2142A SIP	
222	ICV01H	6124035601	H-SINK V,P910+	
223	J001	375300002401	WIRE-NS-S43MM TAP. SDA 1/	
224	J002	375300002401	WIRE-NS-S43MM TAP. SDA 1/	
225	J003	375300002401	WIRE-NS-S43MM TAP. SDA 1/	
226	J004	375300002401	WIRE-NS-S43MM TAP. SDA 1/	
227	J005	375300002401	WIRE-NS-S43MM TAP. SDA 1/	
228	J006	375300002401	WIRE-NS-S43MM TAP. SDA 1/	
229	J007	375300002401	WIRE-NS-S43MM TAP. SDA 1/	
230	J008	375300002401	WIRE-NS-S43MM TAP. SDA 1/	
231	J009	375300002401	WIRE-NS-S43MM TAP. SDA 1/	
232	J010	375300002401	WIRE-NS-S43MM TAP. SDA 1/	
233	J013	375300002401	WIRE-NS-S43MM TAP. SDA 1/	
234	J014	375300002401	WIRE-NS-S43MM TAP. SDA 1/	
235	J015	375300002401	WIRE-NS-S43MM TAP. SDA 1/	
236	J016	375300002401	WIRE-NS-S43MM TAP. SDA 1/	
237	J017	375300002401	WIRE-NS-S43MM TAP. SDA 1/	
238	J018	375300002401	WIRE-NS-S43MM TAP. SDA 1/	
239	J019	375300002401	WIRE-NS-S43MM TAP. SDA 1/	
240	J020	375300002401	WIRE-NS-S43MM TAP. SDA 1/	
241	J021	375300002401	WIRE-NS-S43MM TAP. SDA 1/	
242	J022	375300002401	WIRE-NS-S43MM TAP. SDA 1/	
243	J023	375300002401	WIRE-NS-S43MM TAP. SDA 1/	
244	J024	375300002401	WIRE-NS-S43MM TAP. SDA 1/	
245	J025	375300002401	WIRE-NS-S43MM TAP. SDA 1/	
246	J026	375300002401	WIRE-NS-S43MM TAP. SDA 1/	
247	J027	375300002401	WIRE-NS-S43MM TAP. SDA 1/	
248	J028	375300002401	WIRE-NS-S43MM TAP. SDA 1/	
249	J029	375300002401	WIRE-NS-S43MM TAP. SDA 1/	
250	J030	375300002401	WIRE-NS-S43MM TAP. SDA 1/	
251	J031	375300002401	WIRE-NS-S43MM TAP. SDA 1/	
252	J032	375300002401	WIRE-NS-S43MM TAP. SDA 1/	
253	J033	375300002401	WIRE-NS-S43MM TAP. SDA 1/	
254	J034	375300002401	WIRE-NS-S43MM TAP. SDA 1/	
255	J035	375300002401	WIRE-NS-S43MM TAP. SDA 1/	
256	J036	375300002401	WIRE-NS-S43MM TAP. SDA 1/	
257	J037	375300002401	WIRE-NS-S43MM TAP. SDA 1/	
258	J038	375300002401	WIRE-NS-S43MM TAP. SDA 1/	
259	J039	375300002401	WIRE-NS-S43MM TAP. SDA 1/	
260	J040	375300002401	WIRE-NS-S43MM TAP. SDA 1/	
261	J041	375300002401	WIRE-NS-S43MM TAP. SDA 1/	
262	J042	375300002401	WIRE-NS-S43MM TAP. SDA 1/	
263	J043	375300002401	WIRE-NS-S43MM TAP. SDA 1/	

NUM.	LOCATION	PART NUMBER	DESCRIPTION	REMARK
264	J044	375300002401	WIRE-NS-S43MM TAP. SDA 1/	
265	J045	375300002401	WIRE-NS-S43MM TAP. SDA 1/	
266	J046	375300002401	WIRE-NS-S43MM TAP. SDA 1/	
267	J047	375300002401	WIRE-NS-S43MM TAP. SDA 1/	
268	J048	375300002401	WIRE-NS-S43MM TAP. SDA 1/	
269	J049	375300002401	WIRE-NS-S43MM TAP. SDA 1/	
270	J050	375300002401	WIRE-NS-S43MM TAP. SDA 1/	
271	J051	375300002401	WIRE-NS-S43MM TAP. SDA 1/	
272	J052	375300002401	WIRE-NS-S43MM TAP. SDA 1/	
273	J053	375300002401	WIRE-NS-S43MM TAP. SDA 1/	
274	J054	375300002401	WIRE-NS-S43MM TAP. SDA 1/	
275	J055	375300002401	WIRE-NS-S43MM TAP. SDA 1/	
276	J056	375300002401	WIRE-NS-S43MM TAP. SDA 1/	
277	J057	375300002401	WIRE-NS-S43MM TAP. SDA 1/	
278	J058	375300002401	WIRE-NS-S43MM TAP. SDA 1/	
279	J059	375300002401	WIRE-NS-S43MM TAP. SDA 1/	
280	J060	375300002401	WIRE-NS-S43MM TAP. SDA 1/	
281	J061	375300002401	WIRE-NS-S43MM TAP. SDA 1/	
282	J062	375300002401	WIRE-NS-S43MM TAP. SDA 1/	
283	J063	375300002401	WIRE-NS-S43MM TAP. SDA 1/	
284	J064	375300002401	WIRE-NS-S43MM TAP. SDA 1/	
285	J065	375300002401	WIRE-NS-S43MM TAP. SDA 1/	
286	J066	375300002401	WIRE-NS-S43MM TAP. SDA 1/	
287	J067	375300002401	WIRE-NS-S43MM TAP. SDA 1/	
288	J068	375300002401	WIRE-NS-S43MM TAP. SDA 1/	
289	J069	375300002401	WIRE-NS-S43MM TAP. SDA 1/	
290	J070	375300002401	WIRE-NS-S43MM TAP. SDA 1/	
291	J071	375300002401	WIRE-NS-S43MM TAP. SDA 1/	
292	J072	375300002401	WIRE-NS-S43MM TAP. SDA 1/	
293	J073	375300002401	WIRE-NS-S43MM TAP. SDA 1/	
294	J074	375300002401	WIRE-NS-S43MM TAP. SDA 1/	
295	J075	375300002401	WIRE-NS-S43MM TAP. SDA 1/	
296	J076	375300002401	WIRE-NS-S43MM TAP. SDA 1/	
297	J077	375300002401	WIRE-NS-S43MM TAP. SDA 1/	
298	J078	375300002401	WIRE-NS-S43MM TAP. SDA 1/	
299	J079	375300002401	WIRE-NS-S43MM TAP. SDA 1/	
300	J080	375300002401	WIRE-NS-S43MM TAP. SDA 1/	
301	J081	375300002401	WIRE-NS-S43MM TAP. SDA 1/	
302	J082	375300002401	WIRE-NS-S43MM TAP. SDA 1/	
303	J083	375300002401	WIRE-NS-S43MM TAP. SDA 1/	
304	J084	375300002401	WIRE-NS-S43MM TAP. SDA 1/	
305	J085	375300002401	WIRE-NS-S43MM TAP. SDA 1/	
306	J086	375300002401	WIRE-NS-S43MM TAP. SDA 1/	
307	J087	375300002401	WIRE-NS-S43MM TAP. SDA 1/	

NUM.	LOCATION	PART NUMBER	DESCRIPTION	REMARK
308	J088	375300002401	WIRE-NS-S43MM TAP. SDA 1/	
309	J089	375300002401	WIRE-NS-S43MM TAP. SDA 1/	
310	J090	375300002401	WIRE-NS-S43MM TAP. SDA 1/	
311	J091	375300002401	WIRE-NS-S43MM TAP. SDA 1/	
312	J092	375300002401	WIRE-NS-S43MM TAP. SDA 1/	
313	J093	375300002401	WIRE-NS-S43MM TAP. SDA 1/	
314	J094	375300002401	WIRE-NS-S43MM TAP. SDA 1/	
315	J095	375300002401	WIRE-NS-S43MM TAP. SDA 1/	
316	J096	375300002401	WIRE-NS-S43MM TAP. SDA 1/	
317	J097	375300002401	WIRE-NS-S43MM TAP. SDA 1/	
318	J098	375300002401	WIRE-NS-S43MM TAP. SDA 1/	
319	J099	375300002401	WIRE-NS-S43MM TAP. SDA 1/	
320	J100	375300002401	WIRE-NS-S43MM TAP. SDA 1/	
321	J101	375300002401	WIRE-NS-S43MM TAP. SDA 1/	
322	J102	375300002401	WIRE-NS-S43MM TAP. SDA 1/	
323	J103	375300002401	WIRE-NS-S43MM TAP. SDA 1/	
324	J104	375300002401	WIRE-NS-S43MM TAP. SDA 1/	
325	J107	375300002401	WIRE-NS-S43MM TAP. SDA 1/	
326	J108	375300002401	WIRE-NS-S43MM TAP. SDA 1/	
327	J109	375300002401	WIRE-NS-S43MM TAP. SDA 1/	
328	J110	375300002401	WIRE-NS-S43MM TAP. SDA 1/	
329	JCP1	375300002401	WIRE-NS-S43MM TAP. SDA 1/	
330	JCP2	375300002401	WIRE-NS-S43MM TAP. SDA 1/	
331	JCP3	375300002401	WIRE-NS-S43MM TAP. SDA 1/	
332	JCP4	375300002401	WIRE-NS-S43MM TAP. SDA 1/	
333	JCP5	375300002401	WIRE-NS-S43MM TAP. SDA 1/	
334	LD01	3330600441	LED,A1329B/GYC/R2	
335	LF01	3500101071	INDUCT-FIX,CHOKE 10UH DR0	
336	LF03	E42019058250	COIL,PEAKING 22 UH AXIAL	
337	LH01	3500100493	INDUCT-FIX,AL04TB101K K A	
338	LP01	3520200192	FLT-LC,SQE2828 0.65P 75T	
339	LP02	352020017301	FLT-LC,SQE2115 2MH MIN	
340	NTC1	E4207708409A	THERMISTOR 180HM 13PAI TA	
341	PCON	3720101397	CONN-M,SMW250-03 3	
342	PF01	372010105301	CONN-M,POST 1P DEGT235 14	
343	PTC1	3411300012	POSISTOR,J502972D070Q270	
344	QCP1	TTKSC945CY	TR,KSC945C-Y	
345	QCP2	TTKTC200Y	TR,KTC200Y TAP	
346	QCP3	TTKTA200Y	TR,KTA200Y TAP	
347	QCP4	TTKSC945CY	TR,KSC945C-Y	
348	QCP5	TTKTC200Y	TR,KTC200Y TAP	
349	QCP6	TTKTA200Y	TR,KTA200Y TAP	
350	QCP7	TTKSC945CY	TR,KSC945C-Y	
351	QCP8	TTKTC200Y	TR,KTC200Y TAP	

NUM.	LOCATION	PART NUMBER	DESCRIPTION	REMARK
352	QCP9	TTKTA200Y	TR,KTA200Y TAP	
353	QF01	3114000158	FET,2SK2761-01MR-F130-S07	
354	QF02	TTKSA733CY	TR,KSA733C-Y	
355	QF03	TTKSC945CY	TR,KSC945C-Y	
356	QF04	TTKSC945CY	TR,KSC945C-Y	
357	QF05	3110100689	TR-GEN,KSA1013Y LEAD	
358	QF06	TTKSP45	TR,KSP45	
359	QF07	TTKSC945CY	TR,KSC945C-Y	
360	QF08	3110100641	TR-GEN,KSC5042F LEAD	
361	QF08H	6124035400	H-SINK F,G910	
362	QF09	3110100641	TR-GEN,KSC5042F LEAD	
363	QF09H	6124035400	H-SINK F,G910	
364	QF13	TTKSC945CY	TR,KSC945C-Y	
365	QF14	TTKSA733CY	TR,KSA733C-Y	
366	QH01	TTKSC945CY	TR,KSC945C-Y	
367	QH02	TTKSC945CY	TR,KSC945C-Y	
368	QH03	TTKSA733CY	TR,KSA733C-Y	
369	QH04	3114000152	FET,SFP9644 LEAD	
370	QH04H	B4212501005A	HEAT SINK PWR(N)ANODIZE 4	
371	QH05	TT2N7000	TR,2N7000	
372	QH06	3110100704	TR-GEN,2SC5411(AS) LEAD	
373	QH06H	6124029601	H-SINK H.O.T,G910	
374	QH07	TTKSC945CY	TR,KSC945C-Y	
375	QH08	TTKSC945CY	TR,KSC945C-Y	
376	QH09	3114000178	FET,IRFS640A LEAD	
377	QH09H	6124035500	H-SINK CS,G910	
378	QH10	TTKSC945CY	TR,KSC945C-Y	
379	QH11	3114000171	FET,IRFS630A LEAD	
380	QH12	TTKSC945CY	TR,KSC945C-Y	
381	QH13	3114000124	FET,IRF630A LEAD	
382	QH14	TTKSC945CY	TR,KSC945C-Y	
383	QH15	3114000124	FET,IRF630A LEAD	
384	QH16	3110100680	TR-GEN,BD135 LEAD	
385	QH19	3114000080	FET,2SK2134-S12 LEAD	
386	QH20	TTKTA1015Y	TR,KTA1266Y	
387	QP02	3110100681	TR-GEN,KTC3228Y LEAD	
388	QP03	3110100705	TR-GEN,KRC105M LEAD	
389	QP21	3110100689	TR-GEN,KSA1013Y LEAD	
390	QP22	TTKTC3200BL	TR,LOW NOISE KTC3200BL	
391	QP23	TTKRC102M	TR,SWITCHING KRC102M	
392	QP24	3110100687	TR-GEN,KSA928AY LEAD	
393	QP25	TTKRC102M	TR,SWITCHING KRC102M	
394	QR01	TTKTC200Y	TR,KTC200Y TAP	
395	QR02	TTKTA200Y	TR,KTA200Y TAP	

NUM.	LOCATION	PART NUMBER	DESCRIPTION	REMARK
396	QR03	TTKSC945CY	TR,KSC945C-Y	
397	RCP1	RD-8POT0154J	RES-CF,RD 1/8W 150K OHM J	
398	RCP10	RD-8POT0472J	RES-CF,RD 1/8W 4.7K OHM J	
399	RCP11	RD-4POT0332J	RES-CF,RD 1/4W 3.3K OHM J	
400	RCP12	RD-4POT0330J	RES-CF,RD 1/4W 33 OHM J	
401	RCP13	RD-8POT0472J	RES-CF,RD 1/8W 4.7K OHM J	
402	RCP14	RD-8POT0472J	RES-CF,RD 1/8W 4.7K OHM J	
403	RCP15	RD-8POT0472J	RES-CF,RD 1/8W 4.7K OHM J	
404	RCP2	RD-8POT0472J	RES-CF,RD 1/8W 4.7K OHM J	
405	RCP3	RD-4POT0332J	RES-CF,RD 1/4W 3.3K OHM J	
406	RCP4	RD-4POT0330J	RES-CF,RD 1/4W 33 OHM J	
407	RCP5	RD-8POT0154J	RES-CF,RD 1/8W 150K OHM J	
408	RCP6	RD-8POT0472J	RES-CF,RD 1/8W 4.7K OHM J	
409	RCP7	RD-4POT0332J	RES-CF,RD 1/4W 3.3K OHM J	
410	RCP8	RD-4POT0100J	RES-CF,RD 1/4W 10 OHM J	
411	RCP9	RD-8POT0154J	RES-CF,RD 1/8W 150K OHM J	
412	RF01	2561000007	RES-CEM,100 7W J U	
413	RF02	RD-8POT0273J	RES-CF,RD 1/8W 27K OHM J	
414	RF03	RD-8POT0822J	RES-CF,RD 1/8W 8.2K OHM J	
415	RF04	RD-8POT0273J	RES-CF,RD 1/8W 27K OHM J	
416	RF06	RD-8POT0103J	RES-CF,RD 1/8W 10KOHM J	
417	RF07	RD-8POT0333J	RES-CF,RD 1/8W 33K OHM J	
418	RF08	RD-8POT0100J	RES-CF,RD 1/8W 10 OHM J	
419	RF09	RD-8POT0472J	RES-CF,RD 1/8W 4.7K OHM J	
420	RF10	RD-4POT0331J	RES-CF,RD 1/4W 330 OHM J	
421	RF11	RD-8POT0472J	RES-CF,RD 1/8W 4.7K OHM J	
422	RF12	RD-4POT0102J	RES-CF,RD 1/4W 1K OHM J	
423	RF13	RD-8POT0472J	RES-CF,RD 1/8W 4.7K OHM J	
424	RF14	RD-8POT0513J	RES-CF,RD 1/8W 51K OHM J	
425	RF15	RD-8POT0624J	RES-CF,RD 1/8W 620K OHM J	
426	RF16	RD-8POT0153J	RES-CF,RD 1/8W 15K OHM J	
427	RF17	RD-8POT0103J	RES-CF,RD 1/8W 10KOHM J	
428	RF18	RD-8POT0472J	RES-CF,RD 1/8W 4.7K OHM J	
429	RF19	RD-8POT0101J	RES-CF,RD 1/8W 100 OHM J	
430	RF20	RD-8POT0562J	RES-CF,RD 1/8W 5.6K OHM J	⚠
431	RF21	RD-8POT0103J	RES-CF,RD 1/8W 10KOHM J	⚠
432	RF22	RD-8POT0433J	RES-CF,RD 1/8W 43K OHM J	
433	RF23	RN-4POT1303F	RES-MF,RN 1/4W 130KOHM F	⚠
434	RF25	RD-8POT0123J	RES-CF,RD 1/8W 12KOHM J	
435	RF26	2404300002	RES-CF,430 0.5W J M	
436	RF27	RD-8POT0394J	RES-CF,RD 1/8W 390K OHM J	
437	RF28	RD-8POT0124J	RES-CF,RD 1/8W 120K OHM J	
438	RF29	RD-8POT0103J	RES-CF,RD 1/8W 10KOHM J	
439	RF30	RD-8POT0105J	RES-CF,RD 1/8W 1M OHM J	

NUM.	LOCATION	PART NUMBER	DESCRIPTION	REMARK
440	RF31	RD-8POT0244J	RES-CF,RD 1/8W 240KOHM J	
441	RF33	RD-8POT0222J	RES-CF,RD 1/8W 2.2K OHM J	
442	RF34	RD-8POT0682J	RES-CF,RD 1/8W 6.8K OHM J	
443	RF35	2404700007	RES-CF,470 0.5W J M	
444	RF36	RD-8POT0102J	RES-CF,RD 1/8W 1K OHM J	
445	RF37	RD-8POT0564J	RES-CF,RD 1/8W 560K OHM J	
446	RF38	RD-8POT0513J	RES-CF,RD 1/8W 51K OHM J	
447	RF39	RD-8POT0103J	RES-CF,RD 1/8W 10KOHM J	
448	RF40	RD-8POT0474J	RES-CF,RD 1/8W 470KOHM J	
449	RF41	RD-8POT0242J	RES-CF,RD 1/8W 2.4K OHM J	
450	RF42	RD-8POT0242J	RES-CF,RD 1/8W 2.4K OHM J	
451	RF43	2461000007	RES-MOF,100 1W J M	
452	RF44	246820200301	RES-MOF,82K 2W J R-FORM	
453	RF45	246820200301	RES-MOF,82K 2W J R-FORM	
454	RF46	RD-8POT0153J	RES-CF,RD 1/8W 15K OHM J	
455	RF47	RD-8POT0681J	RES-CF,RD 1/8W 680 OHM J	
456	RF48	2401001010	RES-CF,1K 0.5W J M	
457	RF49	RD-8POT0101J	RES-CF,RD 1/8W 100 OHM J	
458	RF50	RD-8POT0101J	RES-CF,RD 1/8W 100 OHM J	
459	RF51	RD-8POT0103J	RES-CF,RD 1/8W 10KOHM J	
460	RF54	2403300008	RES-CF,330 0.5W J M	
461	RF57	RD-4POT0155J	RES-CF,RD 1/4W 1.5M OHM J	
462	RF58	RD-4POT0155J	RES-CF,RD 1/4W 1.5M OHM J	
463	RF59	RD-8POT0103J	RES-CF,RD 1/8W 10KOHM J	
464	RF60	2401603002	RES-CF,160K 0.125W J A	
465	RF64	RD-8POT0102J	RES-CF,RD 1/8W 1K OHM J	
466	RH01	RN-8POT1502F	RES-MF,RN 1/8W 15K OHM F	⚠
467	RH02	RN-8POT2202F	RES-MF,RN 1/8W 22K OHM F	⚠
468	RH03	RN-8POT1502F	RES-MF,RN 1/8W 15K OHM F	⚠
469	RH04	RD-8POT0102J	RES-CF,RD 1/8W 1K OHM J	
470	RH05	2441452001	RES-MF,14.5K 0.125W F A	
471	RH06	RD-8POT0102J	RES-CF,RD 1/8W 1K OHM J	
472	RH07	RD-8POT0472J	RES-CF,RD 1/8W 4.7K OHM J	
473	RH08	RD-4POT0562J	RES-CF,RD 1/4W 5.6K OHM J	
474	RH09	RN-4POT2702F	RES-MF,RN 1/4W 27K OHM F	
475	RH10	RD-8POT0104J	RES-CF,RD 1/8W 100K OHM J	
476	RH11	RD-8POT0223J	RES-CF,RD 1/8W 22K OHM J	
477	RH12	RD-8POT0101J	RES-CF,RD 1/8W 100 OHM J	
478	RH13	RD-8POT0101J	RES-CF,RD 1/8W 100 OHM J	
479	RH14	RD-8POT0101J	RES-CF,RD 1/8W 100 OHM J	
480	RH15	RD-8POT0101J	RES-CF,RD 1/8W 100 OHM J	
481	RH16	RD-8POT0272J	RES-CF,RD 1/8W 2.7K OHM J	
482	RH17	RD-8POT0101J	RES-CF,RD 1/8W 100 OHM J	
483	RH18	RD-8POT0101J	RES-CF,RD 1/8W 100 OHM J	

NUM.	LOCATION	PART NUMBER	DESCRIPTION	REMARK
484	RH19	RD-8POT0223J	RES-CF,RD 1/8W 22K OHM J	
485	RH20	RD-8POT0332J	RES-CF,RD 1/8W 3.3K OHM J	
486	RH21	2446490001	RES-MF,649 0.25W F A	
487	RH22	RN-4POT2701F	RES-MF,RN 1/4W 2.7KOHM F	
488	RH23	2404700007	RES-CF,470 0.5W J M	
489	RH24	RD-8POT0331J	RES-CF,RD 1/8W 330 OHM J	
490	RH25	RD-4POT0470J	RES-CF,RD 1/4W 47 OHM J	
491	RH26	RD-4POT0510J	RES-CF,RD 1/4W 51 OHM J	
492	RH27	RD-8POT0822J	RES-CF,RD 1/8W 8.2K OHM J	
493	RH28	RD-8POT0331J	RES-CF,RD 1/8W 330 OHM J	
494	RH29	2542208002	RES-FUS,2.2 1W J A	
495	RH30	240270800101	RES-CF,2.7 0.5W J M	
496	RH31	RS03POF0181J	RES-MOF,RS 3W 180 OHM J	
497	RH32	2441201005	RES-MF,1.2K 0.125W F A	
498	RH33	RD-8POT0331J	RES-CF,RD 1/8W 330 OHM J	
499	RH34	2463909004	RES-MOF,39 2W J M	
500	RH35	RD-4POT0681J	RES-CF,RD 1/4W 680 OHM J	
501	RH36	2462009004	RES-MOF,20 2W J M	
502	RH37	RD-8POT0101J	RES-CF,RD 1/8W 100 OHM J	
503	RH38	RD-8POT0103J	RES-CF,RD 1/8W 10KOHM J	
504	RH39	2465600004	RES-MOF,560 1W J M	
505	RH40	2462009004	RES-MOF,20 2W J M	
506	RH41	2462009004	RES-MOF,20 2W J M	
507	RH42	RD-8POT0221J	RES-CF,RD 1/8W 220 OHM J	
508	RH44	240270800101	RES-CF,2.7 0.5W J M	
509	RH45	2460758003	RES-MOF,0.75 3W J M	
510	RH46	RD-8POT0472J	RES-CF,RD 1/8W 4.7K OHM J	
511	RH47	2461201006	RES-MOF,1.2K 2W J M	
512	RH48	240100200901	RES-CF,10K 0.5W J M	
513	RH49	RD-4POT0683J	RES-CF,RD 1/4W 68K OHM J	
514	RH50	RD-8POT0472J	RES-CF,RD 1/8W 4.7K OHM J	
515	RH51	RD-8POT0225J	RES-CF,RD 1/8W 2.2M OHM J	
516	RH52	RD-8POT0472J	RES-CF,RD 1/8W 4.7K OHM J	
517	RH53	RD-8POT0225J	RES-CF,RD 1/8W 2.2M OHM J	
518	RH54	RD-8POT0472J	RES-CF,RD 1/8W 4.7K OHM J	
519	RH55	RD-8POT0224J	RES-CF,RD 1/8W 220KOHM J	
520	RH56	RD-8POT0472J	RES-CF,RD 1/8W 4.7K OHM J	
521	RH57	RD-8POT0224J	RES-CF,RD 1/8W 220KOHM J	
522	RH63	RD-8POT0225J	RES-CF,RD 1/8W 2.2M OHM J	
523	RH64	RD-8POT0472J	RES-CF,RD 1/8W 4.7K OHM J	
524	RH65	RD-8POT0472J	RES-CF,RD 1/8W 4.7K OHM J	
525	RH66	RD-8POT0472J	RES-CF,RD 1/8W 4.7K OHM J	
526	RH67	RD-8POT0472J	RES-CF,RD 1/8W 4.7K OHM J	
527	RH68	RD-8POT0472J	RES-CF,RD 1/8W 4.7K OHM J	

NUM.	LOCATION	PART NUMBER	DESCRIPTION	REMARK
528	RH69	RD-8POT0681J	RES-CF,RD 1/8W 680 OHM J	
529	RH70	RD-4POT04R7J	RES-CF,RD 1/4W 4.7 OHM J	
530	RH72	2462209007	RES-MOF,22 1W J M	
531	RLP01	3710100085	RELAY,DY3M-DC12V 5A 250V	
532	RM01	RD-8POT0103J	RES-CF,RD 1/8W 10KOHM J	
533	RM03	RD-8POT0105J	RES-CF,RD 1/8W 1M OHM J	
534	RM05	RD-8POT0103J	RES-CF,RD 1/8W 10KOHM J	
535	RM06	RD-8POT0103J	RES-CF,RD 1/8W 10KOHM J	
536	RM09	RD-4POT0331J	RES-CF,RD 1/4W 330 OHM J	
537	RM10	RD-4POT0331J	RES-CF,RD 1/4W 330 OHM J	
538	RM12	RD-8POT0101J	RES-CF,RD 1/8W 100 OHM J	
539	RM13	RD-8POT0101J	RES-CF,RD 1/8W 100 OHM J	
540	RM14	RD-8POT0101J	RES-CF,RD 1/8W 100 OHM J	
541	RM15	RD-8POT0101J	RES-CF,RD 1/8W 100 OHM J	
542	RM16	RD-8POT0101J	RES-CF,RD 1/8W 100 OHM J	
543	RM17	RD-8POT0101J	RES-CF,RD 1/8W 100 OHM J	
544	RM18	RD-8POT0472J	RES-CF,RD 1/8W 4.7K OHM J	
545	RM19	RD-8POT0103J	RES-CF,RD 1/8W 10KOHM J	
546	RM20	RD-8POT0472J	RES-CF,RD 1/8W 4.7K OHM J	
547	RM21	RD-8POT0472J	RES-CF,RD 1/8W 4.7K OHM J	
548	RM22	RD-8POT0154J	RES-CF,RD 1/8W 150K OHM J	
549	RM23	RD-8POT0302J	RES-CF,RD 1/8W 3K OHM J	
550	RM24	RD-8POT0472J	RES-CF,RD 1/8W 4.7K OHM J	
551	RM25	RD-8POT0302J	RES-CF,RD 1/8W 3K OHM J	
552	RM29	RD-8POT0153J	RES-CF,RD 1/8W 15K OHM J	
553	RM30	RD-8POT0153J	RES-CF,RD 1/8W 15K OHM J	
554	RM31	RD-8POT0101J	RES-CF,RD 1/8W 100 OHM J	
555	RM32	RD-8POT0101J	RES-CF,RD 1/8W 100 OHM J	
556	RM33	RD-8POT0472J	RES-CF,RD 1/8W 4.7K OHM J	
557	RM34	RD-8POT0472J	RES-CF,RD 1/8W 4.7K OHM J	
558	RM35	RD-8POT0103J	RES-CF,RD 1/8W 10KOHM J	
559	RM37	RD-8POT0752J	RES-CF,RD 1/8W 7.5K OHM J	
560	RM38	RN-4POT1742F	RES-MF,RN 1/4W 17.4KOHM F	
561	RM39	RD-8POT0103J	RES-CF,RD 1/8W 10KOHM J	
562	RM40	RD-8POT0332J	RES-CF,RD 1/8W 3.3K OHM J	
563	RM41	RD-8POT0103J	RES-CF,RD 1/8W 10KOHM J	
564	RP01	2401004008	RES-CF,1M 0.5W J M	
565	RP02	2465602003	RES-MOF,56K 3W J V	
566	RP04	RD-4POT0470J	RES-CF,RD 1/4W 47 OHM J	
567	RP05	2464702006	RES-MOF,47K 1W J M	
568	RP06	RD-8POT0472J	RES-CF,RD 1/8W 4.7K OHM J	
569	RP07	RD-8POT0511J	RES-CF,RD 1/8W 510 OHM J	
570	RP08	246020800201	RES-MOF,0.2 1W J M R-FORM	
571	RP09	2461003006	RES-MOF,100K 1W J M	

NUM.	LOCATION	PART NUMBER	DESCRIPTION	REMARK
572	RP10	RD-4POT0241J	RES-CF,RD 1/4W 240 OHM J	
573	RP11	RD-4POT0301J	RES-CF,RD 1/4W 300 OHM J	
574	RP12	246020800201	RES-MOF,0.2 1W J M R-FORM	
575	RP14	RD-4POT04R7J	RES-CF,RD 1/4W 4.7 OHM J	
576	RP15	RD-8POT0472J	RES-CF,RD 1/8W 4.7K OHM J	
577	RP20	2461203004	RES-MOF,120K 1W J M	
578	RP26	RD-4POT01R0J	RES-CF,RD 1/4W 1 OHM J	
579	RP50	2468202003	RES-MOF,82K 2W J M	
580	RP51	2441783003	RES-MF,178K 0.5W F A	
581	RP52	RN-4POT2201F	RES-MF,RN 1/4W 2.2KOHM F	
582	RP53	RD-8POT0224J	RES-CF,RD 1/8W 220KOHM J	
583	RP54	RD-4POT0102J	RES-CF,RD 1/4W 1K OHM J	
584	RP55	RD-4POT0121J	RES-CF,RD 1/4W 120 OHM J	
585	RP56	2462208007	RES-MOF,2.2 1W J M	
586	RP57	RD-4POT0681J	RES-CF,RD 1/4W 680 OHM J	
587	RP59	2402208006	RES-CF,2.2 0.5W J M	
588	RP60	2464309002	RES-MOF,43 3W J M	
589	RP61	2401001010	RES-CF,1K 0.5W J M	
590	RP62	2464308002	RES-MOF,4.3 1W J M	
591	RP63	RD-4POT0221J	RES-CF,RD 1/4W 220 OHM J	
592	RP64	RD-8POT0823J	RES-CF,RD 1/8W 82K OHM J	
593	RP65	2404702010	RES-CF,47K 0.5W J M	
594	RP66	RS02P0F0680J	RES-MOF,2W 68 OHM J	
595	RR01	RD-4POT0100J	RES-CF,RD 1/4W 10 OHM J	
596	RR02	RD-8POT0272J	RES-CF,RD 1/8W 2.7K OHM J	
597	RR03	RD-8POT0472J	RES-CF,RD 1/8W 4.7K OHM J	
598	RV01	RD-8POT0752J	RES-CF,RD 1/8W 7.5K OHM J	
599	RV02	RD-8POT0682J	RES-CF,RD 1/8W 6.8K OHM J	
600	RV03	2400478002	RES-CF,0.47 0.5W J M	
601	RV04	2400478002	RES-CF,0.47 0.5W J M	
602	RV05	2401008007	RES-CF,1 0.5W J M	
603	RV06	RD-4POT0562J	RES-CF,RD 1/4W 5.6K OHM J	
604	RV07	2461208006	RES-MOF,1.2 1W J M	
605	RV08	RD-8POT0562J	RES-CF,RD 1/8W 5.6K OHM J	
606	RV09	RD-8POT0752J	RES-CF,RD 1/8W 7.5K OHM J	
607	RV10	RN-4POT6801F	RES-MF,RN 1/4W 6.8KOHM F	
608	RV11	RD-4POT0102J	RES-CF,RD 1/4W 1K OHM J	
609	RV12	RD-4POT0222J	RES-CF,RD 1/4W 2.2K OHM J	
610	SWB01	3700800117	SW-PUSH,CPS-1202 30V 0.3A	
611	SWH01	E42027014010	LEVER SWITCH,30'C 3P	
612	SWM02	E42027039010	SWITCH TACT,5MM 160GF VER	
613	SWM03	E42027039010	SWITCH TACT,5MM 160GF VER	
614	SWM04	E42027039010	SWITCH TACT,5MM 160GF VER	
615	SWM05	E42027039010	SWITCH TACT,5MM 160GF VER	

NUM.	LOCATION	PART NUMBER	DESCRIPTION	REMARK
616	TH01	3510300160	TRAN-SW,HDT EI1916 G910	
617	TH02	3510300161	TRAN-SW,EI3026 PULSE G910	
618	TH03	3510300162	TRAN-SW,EI1916 AFC G910	
619	TH04	3500101850	INDUCT-FIX,LIN 20.5T K IH	
620	TH05	3510500081	FBT,G210	⚠
621	TP01	351020011903	TRAN-PW,MAIN EER4042 G210	
622	TP02	E4203109004A	TRANS SYNC,UU1116 TUBE	
623	VCON	3720101837	CONN-M,BH 2B-PH 2	
624	VRF01	3410300275	VR-S-FIX,RH0614C 10K 10K	⚠
625	WP01	372010121702	CONN-M,AC INNET DSC-14S2	
626	XM01	3530200581	VIB-QUARTZ,12MHZ 22PF ATS	
627		E4208518403	PCBA MA(I1*),G210/BNC PFC	
628		E4208818403	PCBA MA(I2*),G210/BNC PFC	
629		E4208918403	PCBA MA(I3*),G210/BNC PFC	
630		E4208418463	PCBA MA(A6*),G210/BNC PFC	
631		E4208418453	PCBA MA(A5*),G210/BNC PFC	
632		E4208418443	PCBA MA(A4*),G210/BNC PFC	
633		304010087101	PCB-SINGLE,P910+ /HMO PFC/	
634		372500517201	CONN-A,4P CBL PFC	

CRT

NUM.	LOCATION	PART NUMBER	DESCRIPTION	REMARK
1	BC01	3540200059	BD-FER,BFS3580	
2	BC02	3540200058	BD-FER,BFS3550	
3	BC03	3540200058	BD-FER,BFS3550	
4	BC04	3540200059	BD-FER,BFS3580	
5	BC05	3540200059	BD-FER,BFS3580	
6	BC06	3540200059	BD-FER,BFS3580	
7	CC01	2131040020	CAP-MULT,0.1UF 50V Z AXI	
8	CC02	2131040020	CAP-MULT,0.1UF 50V Z AXI	
9	CC03	2131040020	CAP-MULT,0.1UF 50V Z AXI	
10	CC04	CE04BT1C331M	CAP-EL,SMS 16V 330UF M	
11	CC05	2131040020	CAP-MULT,0.1UF 50V Z AXI	
12	CC06	2131040020	CAP-MULT,0.1UF 50V Z AXI	
13	CC08	2131040020	CAP-MULT,0.1UF 50V Z AXI	
14	CC09	2131040020	CAP-MULT,0.1UF 50V Z AXI	
15	CC10	2131040020	CAP-MULT,0.1UF 50V Z AXI	
16	CC11	2178210005	CAP-P-F,820PF 100V J RAD	
17	CC12	CE04BT1HR47M	CAP-EL,SMS 50V 0.47UF M	
18	CC13	CE04BT1C101M	CAP-EL,SMS 16V 100UF M	
19	CC14	2131040020	CAP-MULT,0.1UF 50V Z AXI	
20	CC15	CE04BT1C101M	CAP-EL,SMS 16V 100UF M	
21	CC16	CE04BT1C101M	CAP-EL,SMS 16V 100UF M	
22	CC17	2131040020	CAP-MULT,0.1UF 50V Z AXI	
23	CC18	CQ92BT2A103J	CAP-PE,100V 0.01UF J	
24	CC19	CQ92BT2A103J	CAP-PE,100V 0.01UF J	
25	CC20	CE04BT1C221M	CAP-EL,SMS 16V 220UF M	
26	CC21	2131040020	CAP-MULT,0.1UF 50V Z AXI	
27	CC22	CE04BT2A101M	CAP-EL,SMS 100V 100UF M	
28	CC23	CQ92BT2A104J	CAP-PE,100V 0.1UF J	
29	CC24	2001090053	CAP-AL,1UF 100V M 5*11 NP	
30	CC25	2001090053	CAP-AL,1UF 100V M 5*11 NP	
31	CC26	2001090053	CAP-AL,1UF 100V M 5*11 NP	
32	CC27	2002280012	CAP-AL,0.22UF 160V M 5*11	
33	CC28	2002280012	CAP-AL,0.22UF 160V M 5*11	
34	CC29	2002280012	CAP-AL,0.22UF 160V M 5*11	
35	CC30	CE04BT1C101M	CAP-EL,SMS 16V 100UF M	
36	CC31	CE04BT1C470M	CAP-EL,SMS 16V 47UF M	
37	CC32	CK45BN2H472K	CAP-CD,500V 4700PF K	
38	CC33	2102230017	CAP-CER,0.022UF 1KV J Z4U	
39	CC34	CE04BT2C100M	CAP-EL,SMS 160V 10UF M	
40	CC36	2102230017	CAP-CER,0.022UF 1KV J Z4U	
41	CC37	2178210005	CAP-P-F,820PF 100V J RAD	
42	CC39	2003300042	CAP-AL,33UF 100V M 8*11.5	
43	CC40	CQ92BT2A104J	CAP-PE,100V 0.1UF J	
44	CC41	CC45CT1H221J	CAP-CD,50V 220PF J NPO	
45	CC43	2133900001	CAP-MULT,39PF 50V J AXI	

NUM.	LOCATION	PART NUMBER	DESCRIPTION	REMARK
46	CNC01	372010191601	CONN-M,SMAW200-14	
47	CNC02	372010136201	CONN-M,SMAW250-06 6	
48	CNC02	372500497102	CONN-A,RGB CABLE P910+	
49	CNC03	3721101187	CONN-F,CRT SKT ISDW01S P9	
50	DC01	DTISS81	DIODE,SWITCHING ISS81	
51	DC02	DTISS81	DIODE,SWITCHING ISS81	
52	DC03	DTISS81	DIODE,SWITCHING ISS81	
53	DC04	DTISS81	DIODE,SWITCHING ISS81	
54	DC05	DTISS81	DIODE,SWITCHING ISS81	
55	DC06	DTISS81	DIODE,SWITCHING ISS81	
56	DC07	DTISS81	DIODE,SWITCHING ISS81	
57	DC08	DTISS81	DIODE,SWITCHING ISS81	
58	DC09	DTISS81	DIODE,SWITCHING ISS81	
59	FC01	E42029026410	FILTER,EMI 50V 0.1UF M	
60	FC02	E42029012020	NOISE FILTER,TH28123MA	
61	ICC01	3200001434	IC-LIN,S1D2506A01-D0B1	
62	ICC01H	6124035300	H-SINK IC,G910	
63	ICC02	3204000577	IC-INT,MTV021 9LANGUAGE D	
64	ICC03	3200001490	IC-LIN,LM2413T TO2	
65	ICC03H	6124035700	H-SINK VIDEO,G910	
66	JC01	375300002401	WIRE-NS-S43MM TAP. SDA 1/	
67	JC02	375300002401	WIRE-NS-S43MM TAP. SDA 1/	
68	JC03	375300002401	WIRE-NS-S43MM TAP. SDA 1/	
69	JC04	375300002401	WIRE-NS-S43MM TAP. SDA 1/	
70	JC05	375300002401	WIRE-NS-S43MM TAP. SDA 1/	
71	JC06	375300002401	WIRE-NS-S43MM TAP. SDA 1/	
72	JC07	3540200057	BD-FER,BFS2550	
73	JC08	3540200057	BD-FER,BFS2550	
74	JC09	3540200057	BD-FER,BFS2550	
75	JC10	375300002401	WIRE-NS-S43MM TAP. SDA 1/	
76	JC11	375300002401	WIRE-NS-S43MM TAP. SDA 1/	
77	JC12	375300002401	WIRE-NS-S43MM TAP. SDA 1/	
78	JC13	375300002401	WIRE-NS-S43MM TAP. SDA 1/	
79	JC14	375300002401	WIRE-NS-S43MM TAP. SDA 1/	
80	LC01	3500100636	INDUCT-FIX,AL04TBR22M M A	
81	LC02	3500100636	INDUCT-FIX,AL04TBR22M M A	
82	LC03	3500100636	INDUCT-FIX,AL04TBR22M M A	
83	PCGW	372010105301	CONN-M,POST 1P DEGT235 14	
84	PG2	3720101316	CONN-M,DPP-150 1	
85	QC01	TTKTA1015Y	TR,KTA1266Y	
86	QC02	TTKTA1015Y	TR,KTA1266Y	
87	QC03	TTKSP92	TR,KSP92	
88	QC04	TTKSP42	TR,KSP42	
89	QC05	TTKSP92	TR,KSP92	
90	QC06	TTKSP42	TR,KSP42	
91	QC07	TTKSP92	TR,KSP92	

NUM.	LOCATION	PART NUMBER	DESCRIPTION	REMARK
92	QC08	TTKSP42	TR,KSP42	
93	QC12	TTKSC945CY	TR,KSC945C-Y	
94	RC01	RD-8POT0103J	RES-CF,RD 1/8W 10KOHM J	
95	RC02	RD-8POT0122J	RES-CF,RD 1/8W 1.2K OHM J	
96	RC03	RD-8POT0101J	RES-CF,RD 1/8W 100 OHM J	
97	RC04	RD-8POT0303J	RES-CF,RD 1/8W 30K OHM J	
98	RC05	RD-8POT0103J	RES-CF,RD 1/8W 10KOHM J	
99	RC06	RD-8POT0102J	RES-CF,RD 1/8W 1K OHM J	
100	RC07	RD-8POT0102J	RES-CF,RD 1/8W 1K OHM J	
101	RC08	RD-8POT0431J	RES-CF,RD 1/8W 430 OHM J	
102	RC09	RD-8POT0431J	RES-CF,RD 1/8W 430 OHM J	
103	RC10	RD-8POT0431J	RES-CF,RD 1/8W 430 OHM J	
104	RC11	RD-8POT0101J	RES-CF,RD 1/8W 100 OHM J	
105	RC12	RD-8POT0101J	RES-CF,RD 1/8W 100 OHM J	
106	RC13	RD-8POT0331J	RES-CF,RD 1/8W 330 OHM J	
107	RC14	RD-8POT0331J	RES-CF,RD 1/8W 330 OHM J	
108	RC15	RD-8POT0331J	RES-CF,RD 1/8W 330 OHM J	
109	RC16	RD-8POT0331J	RES-CF,RD 1/8W 330 OHM J	
110	RC18	RD-8POT0102J	RES-CF,RD 1/8W 1K OHM J	
111	RC19	RD-8POT0331J	RES-CF,RD 1/8W 330 OHM J	
112	RC20	RD-8POT0331J	RES-CF,RD 1/8W 330 OHM J	
113	RC21	RD-8POT0151J	RES-CF,RD 1/8W 150 OHM J	
114	RC22	RD-8POT0105J	RES-CF,RD 1/8W 1M OHM J	
115	RC23	RD-8POT0562J	RES-CF,RD 1/8W 5.6K OHM J	
116	RC24	RD-8POT0622J	RES-CF,RD 1/8W 6.2K OHM J	
117	RC25	RD-8POT0562J	RES-CF,RD 1/8W 5.6K OHM J	
118	RC26	RD-4POT0330J	RES-CF,RD 1/4W 33 OHM J	
119	RC27	RD-4POT0330J	RES-CF,RD 1/4W 33 OHM J	
120	RC28	RD-4POT0330J	RES-CF,RD 1/4W 33 OHM J	
121	RC29	2461200007	RES-MOF,120 1W J M	
122	RC30	2461200007	RES-MOF,120 1W J M	
123	RC31	2461000007	RES-MOF,100 1W J M	
124	RC32	2403309005	RES-CF,33 0.5W J M	
125	RC33	2403309005	RES-CF,33 0.5W J M	
126	RC34	2403309005	RES-CF,33 0.5W J M	
127	RC35	2401000008	RES-CF,100 0.5W J M	
128	RC36	2401000008	RES-CF,100 0.5W J M	
129	RC37	RD-8POT0623J	RES-CF,RD 1/8W 62K OHM J	
130	RC38	RD-8POT0623J	RES-CF,RD 1/8W 62K OHM J	
131	RC39	RD-8POT0623J	RES-CF,RD 1/8W 62K OHM J	
132	RC40	RD-8POT0104J	RES-CF,RD 1/8W 100K OHM J	
133	RC41	RD-8POT0104J	RES-CF,RD 1/8W 100K OHM J	
134	RC42	RD-8POT0104J	RES-CF,RD 1/8W 100K OHM J	
135	RC43	RD-4POT0101J	RES-CF,RD 1/4W 100 OHM J	
136	RC44	RD-4POT0101J	RES-CF,RD 1/4W 100 OHM J	
137	RC45	RD-4POT0101J	RES-CF,RD 1/4W 100 OHM J	

NUM.	LOCATION	PART NUMBER	DESCRIPTION	REMARK
138	RC53	RD-8P0T0103J	RES-CF,RD 1/8W 10KOHM J	
139	RC54	RD-8P0T0822J	RES-CF,RD 1/8W 8.2K OHM J	
140	RC55	RD-8P0T0561J	RES-CF,RD 1/8W 560 OHM J	
141	RC56	RD-4P0T0104J	RES-CF,RD 1/4W 100K OHM J	
142	SGC01	3411100083	VARISTOR,SURGE ABSORBER R	
143	SGC02	3411100083	VARISTOR,SURGE ABSORBER R	
144	SGC03	3411100083	VARISTOR,SURGE ABSORBER R	
145	SGC04	3411100084	VARISTOR,SURGE ABSORBER R	
146	SGC05	3411100043	VARISTOR,S23 1500V 1500V	
147		E4208618402	PCBA CRT(T1*),G210	
148		E4208518402	PCBA CRT(I1*),G210	
149		E4208918402	PCBA CRT(I3*),G210	
150		E4208417162	PCBA CRT(A6*),P910+ BNC	
151		E4208417152	PCBA CRT(A5*),P910+ BNC	
152		E4208417142	PCBA CRT(A4*),P910+ BNC	
153		304010085303	PCB-SINGLE,P910+ CRT FR1	

BNC

NUM.	LOCATION	PART NUMBER	DESCRIPTION	REMARK
1	CI01	200470009702	CAP-AL,47UF 16V M 6.3*5 P	
2	CI02	200470009702	CAP-AL,47UF 16V M 6.3*5 P	
3	CI03	200470009702	CAP-AL,47UF 16V M 6.3*5 P	
4	CI04	200470009702	CAP-AL,47UF 16V M 6.3*5 P	
5	CI05	200470009702	CAP-AL,47UF 16V M 6.3*5 P	
6	CI06	200470009702	CAP-AL,47UF 16V M 6.3*5 P	
7	CI07	CQ92BT2A103J	CAP-PE,100V 0.01UF J	
8	CI08	CQ92BT2A103J	CAP-PE,100V 0.01UF J	
9	CI09	2131040020	CAP-MULT,0.1UF 50V Z AXI	
10	CI10	CE04HT1H010M	CAP-EL,NHPF 50V 1UF M TAP	
11	CI11	CQ92PT2A471J	CAP-PP,100V 470PF J	
12	CI12	2002210087	CAP-AL,220UF 10V M 8*5 P	
13	CI13	2001010121	CAP-AL,100UF 16V M 8*5 P	
14	CNI01	3720101917	CONN-M,YBH254-09 9	
15	CNI02	3720101362	CONN-M,SMW250-06 6	
16	DD01	DT1N4148	DIODE,1N4148 TAPING	
17	DD02	DT1N4148	DIODE,1N4148 TAPING	
18	DD03	DT1N4148	DIODE,1N4148 TAPING	
19	DD04	DT1N4148	DIODE,1N4148 TAPING	
20	DD05	DT1N4148	DIODE,1N4148 TAPING	
21	DD06	DT1N4148	DIODE,1N4148 TAPING	
22	DD07	DTUZ-6.2BSB	DIODE,ZENER UZ-6.2BSB T	
23	DD08	DTUZ-6.2BSB	DIODE,ZENER UZ-6.2BSB T	
24	DI01	DT1N4148	DIODE,1N4148 TAPING	
25	DI02	DT1N4148	DIODE,1N4148 TAPING	
26	DI03	DT1N4148	DIODE,1N4148 TAPING	
27	DI04	DT1N4148	DIODE,1N4148 TAPING	
28	DI05	DT1N4148	DIODE,1N4148 TAPING	
29	DI06	DT1N4148	DIODE,1N4148 TAPING	
30	DI07	DTUZ-6.2BSB	DIODE,ZENER UZ-6.2BSB T	
31	DI08	DTUZ-6.2BSB	DIODE,ZENER UZ-6.2BSB T	
32	DSI01	372110091801	CONN-F,BNC(5)+ DSUB(15P) A	
33	ICI01	3200001420	IC-LIN,BA7657S SDIP	
34	JI01	375300002401	WIRE-NS-S43MM TAP. SDA 1/	
35	JI02	375300002401	WIRE-NS-S43MM TAP. SDA 1/	
36	JI03	375300002401	WIRE-NS-S43MM TAP. SDA 1/	
37	JI04	375300002401	WIRE-NS-S43MM TAP. SDA 1/	
38	JI05	375300002401	WIRE-NS-S43MM TAP. SDA 1/	
39	JI06	375300002401	WIRE-NS-S43MM TAP. SDA 1/	
40	LI01	3500100493	INDUCT-FIX,AL04TB101K K A	
41	QI01	TT2N7000	TR,2N7000	
42	QI02	TTKSC945CY	TR,KSC945C-Y	
43	RD01	RD-8P0T0750J	RES-CF,RD 1/8W 75 OHM J	
44	RD02	RD-8P0T0750J	RES-CF,RD 1/8W 75 OHM J	
45	RD03	RD-8P0T0750J	RES-CF,RD 1/8W 75 OHM J	

NUM.	LOCATION	PART NUMBER	DESCRIPTION	REMARK
46	RI01	RD-8P0T0750J	RES-CF,RD 1/8W 75 OHM J	
47	RI02	RD-8P0T0750J	RES-CF,RD 1/8W 75 OHM J	
48	RI03	RD-8P0T0750J	RES-CF,RD 1/8W 75 OHM J	
49	RI04	RD-8P0T0474J	RES-CF,RD 1/8W 470KOHM J	
50	RI05	RD-8P0T0101J	RES-CF,RD 1/8W 100 OHM J	
51	RI06	RD-8P0T0101J	RES-CF,RD 1/8W 100 OHM J	
52	RI07	RD-8P0T0300J	RES-CF,RD 1/8W 30 OHM J	
53	RI08	RD-8P0T0102J	RES-CF,RD 1/8W 1K OHM J	
54	RI09	RD-8P0T0623J	RES-CF,RD 1/8W 62K OHM J	
55	RI10	RD-8P0T0101J	RES-CF,RD 1/8W 100 OHM J	
56	RI11	RD-8P0T0101J	RES-CF,RD 1/8W 100 OHM J	
57	RI12	RD-8P0T0101J	RES-CF,RD 1/8W 100 OHM J	
58	RI13	RD-8P0T0472J	RES-CF,RD 1/8W 4.7K OHM J	
59	RI14	RD-8P0T0101J	RES-CF,RD 1/8W 100 OHM J	
60	RI15	RD-8P0T0101J	RES-CF,RD 1/8W 100 OHM J	
61		E4208617103	PCBA BNC(T1*),P910+	
62		E4208517103	PCBA BNC(I1*),P910+	
63		E4208417153	PCBA BNC(A5*),P910+	
64		E4208417143	PCBA BNC(A4*),P910+	
65		304010085402	PCB-SINGLE,G910 BNC F1 1	

PFC

NUM.	LOCATION	PART NUMBER	DESCRIPTION	REMARK
1	CF01	214854000101	CAP-M-P,400V 854J 20.0 T	
2	CF02	CE04BT1C100M	CAP-EL,SMS 16V 10UF M TAP	
3	CF03	CQ92BT2A102J	CAP-PE,100V 0.001UF J	
4	CF04	CF93BT1J224J	CAP-MPE,63V 0.22UF J	
5	CF05	CC45CT1H221J	CAP-CD,50V 220PF J NPO	
6	CF06	2102210019	CAP-CER,220PF 500V J COG	
7	CF07	214104002701	CAP-M-P,104J 630V 7.5 T	
8	CONF01	3720101397	CONN-M,SMW250-03 3	
9	CONF02	3720101302	CONN-M,YW396-03V(2ND P DE	
10	CONF03	3720101302	CONN-M,YW396-03V(2ND P DE	
11	DF01	3100500181	DI-SW,GUR460L-5703 LEAD	
12	DF02	DTUZ-13B	DIODE,ZENER UZ-13B	
13	ICF01	3200001502	IC-LIN,MC33260 DIP	
14	QF01	B4212501010A	HEAT SINK PWR,26MM NON-AN	
15	QF01	3114000183	FET,FQPF9N50 LEAD	
16	QF02	TTKSC945CY	TR,KSC945C-Y	
17	RF01	RD-4P0T0271J	RES-CF,RD 1/4W 270 OHM J	
18	RF02	RD-8P0T0100J	RES-CF,RD 1/8W 10 OHM J	
19	RF03	RD-8P0T0103J	RES-CF,RD 1/8W 10KOHM J	
20	RF04	2402004002	RES-CF,2M 0.5W J M	
21	RF05	RD-4P0T0223J	RES-CF,RD 1/4W 22K OHM J	
22	RF06	RD-4P0T0153J	RES-CF,RD 1/4W 15K OHM J	
23	RF07	2460228005	RES-MOF,0.22 3W J V	
24	RF08	RD-8P0T0223J	RES-CF,RD 1/8W 22K OHM J	
25	RF09	RS03P0F0220J	RES-MOF,3W 22 OHM J	
26	RF10	RD-4P0T0153J	RES-CF,RD 1/4W 15K OHM J	
27	RF11	RD-4P0T0332J	RES-CF,RD 1/4W 3.3K OHM J	
28	RF12	RD-8P0T0472J	RES-CF,RD 1/8W 4.7K OHM J	
29	TF01	3510300178	TRAN-SW,PFC TRANS EE2821	
30		E4208618202	PCBA PFC(T1*),F910	
31		E4208518203	PCBA PFC(I1*),B790+	
32		E4208918203	PCBA PFC(I3*),B790+	
33		E4208418262	PCBA PFC(A6*),B790+	
34		E4208418252	PCBA PFC(A5*),B790+	
35		E4208418242	PCBA PFC(A4*),B790+	
36		304010087002	PCB-SINGLE,PFC ASSY F1	

NUM.	LOCATION	PART NUMBER	DESCRIPTION	REMARK
1		3010100134	CRT,M51QBN291X112 21" 0.2	⚠
2		3500101851	INDUCT-FIX,D-COIL,G210 0.	
3		3500101852	INDUCT-FIX,PURITY COIL 0.	
4		3540400020	MAG-FER,SN20 OP18.4*28-9.	
5		3755000902	WIRE-ASS'Y,CRT GND WIRE G	
6		3758000200	CBL-PWR,MW WALL 1.8MT EUR	
7		3758500421	CBL-SGN,7PAI 1.5M 1C MW S	
8		5003000045	SCREW,TRS+ MC 5*28 SM ZPC	
9		5004000187	SCR-TT2,BIN(+) MC 4*14	
10		5004000204	SCR-TT,BIN + MC 3*8	
11		6101199403	CHASSIS MAIN,P910+	
12		6101207202	CHASSIS MAIN ASSY,P910+	
13		6101217000	CHASSIS LEFT,G210	
14		6101217100	CHASSIS RIGHT,G210	
15		6101217500	CHASSIS LEFT ASSY,G210	
16		6101217600	CHASSIS RIGHT ASSY,G210	
17		6110256000	BKT H/S,G910	
18		6110256100	BKT REAR ASSY,G910	
19		6110260700	BKT PFC,P910+	
20		6120026001	GND-PL,GROUND FINGER G910	
21		6120030100	GND-PL,SRTING T5870C	
22		6120030100	GND-PL,SRTING T5870C	
23		6120042600	CRT SPRING,V770	
24		6120042800	SHIELD GROUND SPRING,V770	
25		6120044100	SHLD-PL,BKT BNC COVER G91	
26		6120045500	SHLD-CASE,CRT P910+	
27		6120045600	SHLD-CASE,CRT COVER P910+	
28		6120048500	SHLD-CASE COVER,G210	
29		6120048600	SHLD-PL,G910/P911 MCU COV	
30		6120048900	SHLD-CASE COVER ASSY,G210	
31		6124029211	H-SINK PWR FET A,G210	
32		6124029601	H-SINK H.O.T,G910	
33		6124031302	H-SINK TR C,HT-7770C	
34		6124035300	H-SINK IC,G910	
35		6124035400	H-SINK F,G910	
36		6124035500	H-SINK CS,G910	
37		6124035601	H-SINK V,P910+	
38		6124035700	H-SINK VIDEO,G910	
39		6129027600	SPECIAL,T.T/W(+) 3*8 MSZP	
40		6130023000	PEM,P790(PAI 7.0) SUM24L	
41		6201281100	SWIVEL UPPER,G910	
42		6201281200	SWIVEL BASE,G910	
43		6201283100	SWIVEL ASSY,G910	
44		6201291900	COVER FRONT,G210	
45		6201292000	COVER REAR,G210	

NUM.	LOCATION	PART NUMBER	DESCRIPTION	REMARK
46		6201292100	COVER CAP,G210	
47		6201292700	HOUSING,COVER F.ASSY,G210	
48		6215235600	KNOB TACT A,G210 ABS(HB)	
49		6215235700	KNOB TACT B,G210 ABS(HB)	
50		6215235800	KNOB POWER,G210 ABS(HB)	
51		6220084300	LENS LED POWER,G210	
52		6223077000	SUPPORT,P910+ TWIST LOCK	
53		6223077500	BKT MOLD,G210	
54		6223077600	SUPPORT,G210 WIRE SADDLE	
55		6225032801	INSULATION ANODE,G210 NEW	
56		6253063407	PAD SPONGE,T=15 G210	
57		6253112200	CUSHION TOP,G210	
58		6253112300	CUSHION BOTTOM,G210	
59		6261022102	RUBBER PCB(NEW),ALL MODEL	
60		6262004001	RUBBER FOOT	
61		6301189900	BOX CTN,DW-2 G210 EXP	
62		6316345101	STICKER CABINET,TCO '99	
63		6316345214	LABEL BACK,F770D HEI(EXP)	
64		351020011903	TRAN-PW,MAIN EER4042 G210	
65		372500517201	CONN-A,4P CBL PFC	
66		375400001605	WIRE-NS-M,1.0T<-TBC->0.3T	
67		632023020701	USER-GUIDE,CD L50A EXP	
68		632703520101	SHEET,INSTALLING GUIDE,V*	
69		B4008500100A	CABLE TIE	
70		B4008500100A	CABLE TIE	
71		B4204505100C	LABEL,X-RAY WARNING	
72		B4204513264B	LABEL,B/CODE 82KHZ(DIC547	
73		B4204665001	KIT LABEL,G210+/99 HED	
74		B4210326101	PCAKING ASSY,G210 CD	
75		B4210326201	KIT COVER,G210 ABS-HB	
76		B4212501005A	HEAT SINK PWR(N)ANODIZE 4	
77		B4212501010A	HEAT SINK PWR,26MM NON-AN	
78		B4214000301A	SPRING COMPRESSION	
79		B4218500201C	RETAINER COIL	
80		B4218501101A	RING INSULATOR	
81		B4219510402A	BAG PE(SET)	
82		E42027014010	LEVER SWITCH,30'C 3P	
83		E4203109004A	TRANS SYNC,UU1116 TUBE	
84		E4205016202	MAIN ASSY,G210/BNC PFC EX	
85		M11143008012	SCREW,BIN(+) M3*8 MSZPC	
86		M11143010012	SCREW,BIN(+) 3X10 MSZPC	
87		M13443006012	SCREW,ST2BIN(+)3*6 MSZPC	
88		M14443008012	SCREW,TT2 BIN(+)3*8 MSZPC	
89		M31100030012	NUT HEX,6N1-3 MSZPC	
90		M31100030012	NUT HEX,6N1-3 MSZPC	

MODEL: G210
CHASSIS NO: C-2105

MODEL TYPE NO: C21R05110

PCB REV. 01

PCB REV. 01

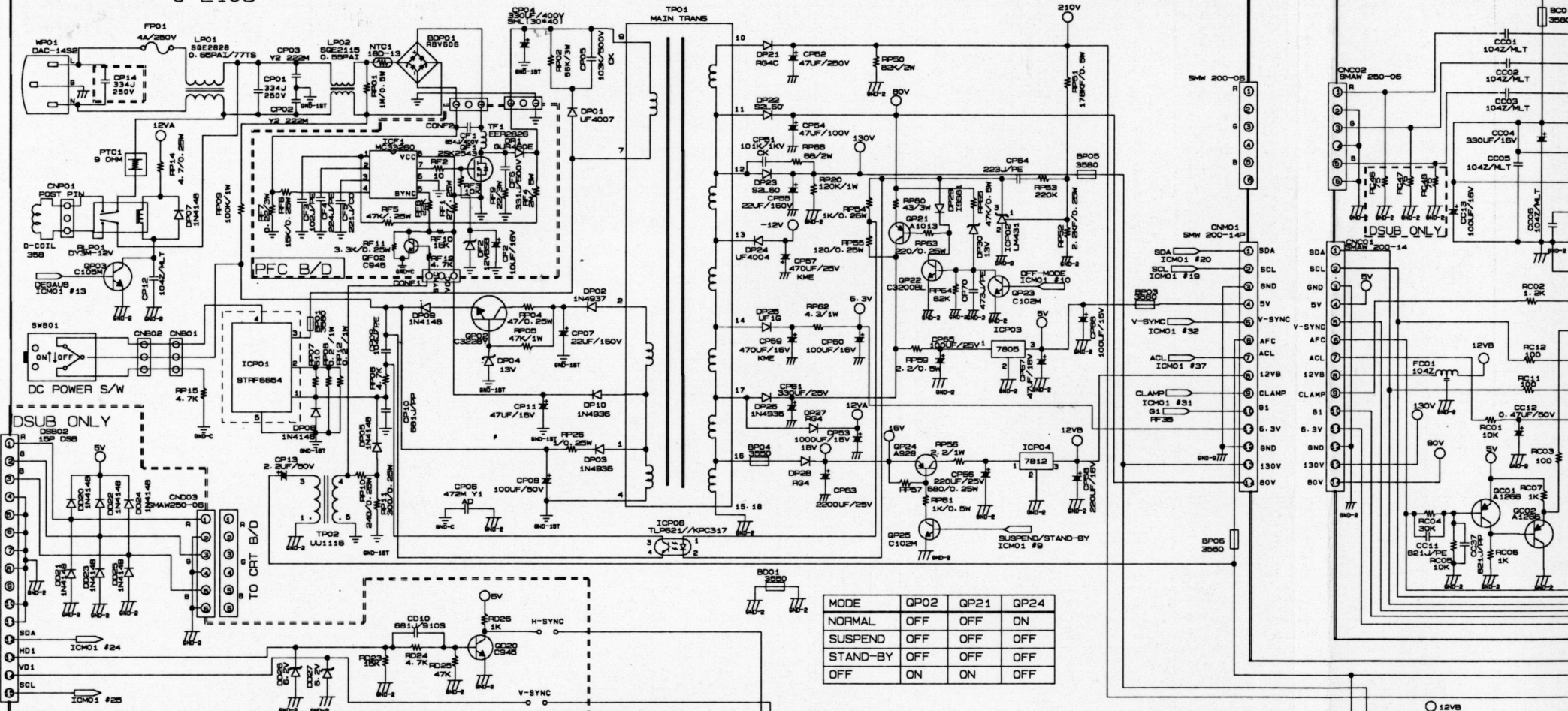

MODE	QP02	QP21	QP24
NORMAL	OFF	OFF	ON
SUSPEND	OFF	OFF	OFF
STAND-BY	OFF	OFF	OFF
OFF	ON	ON	OFF

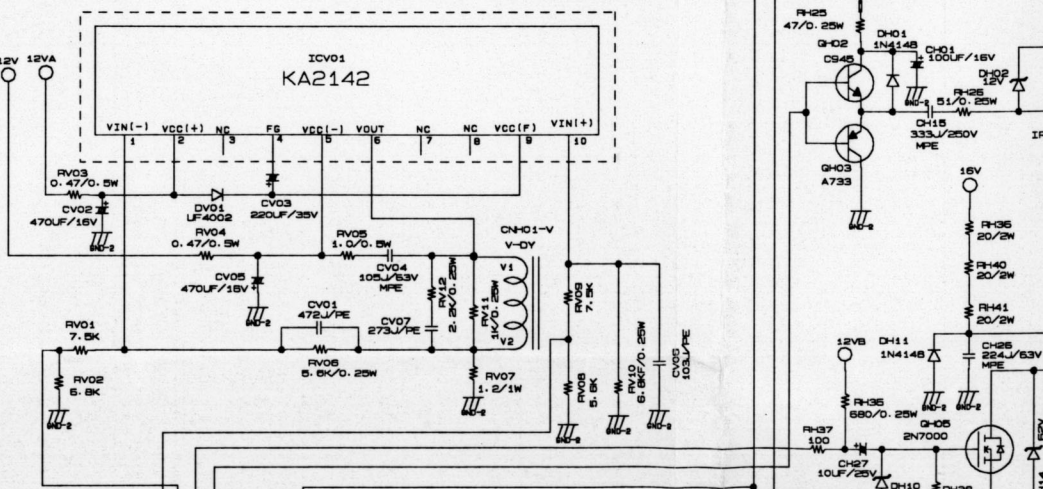
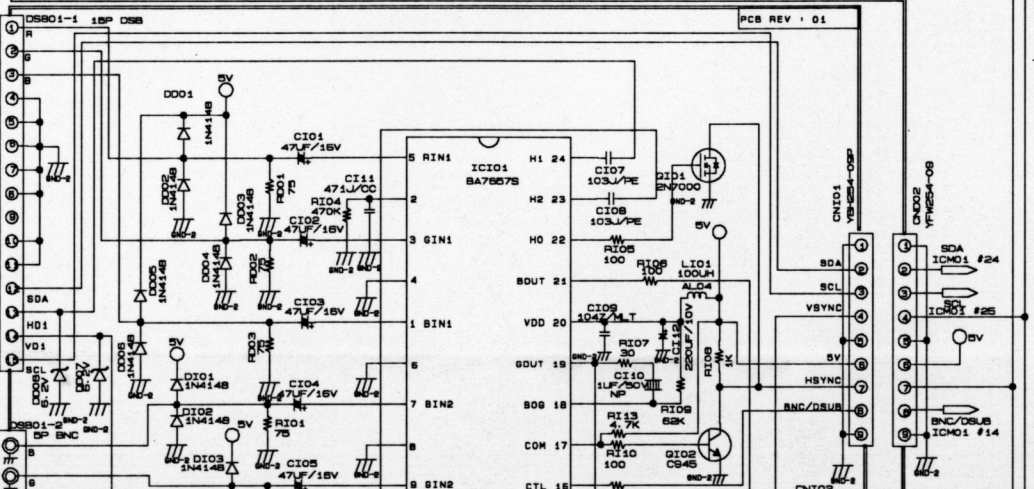

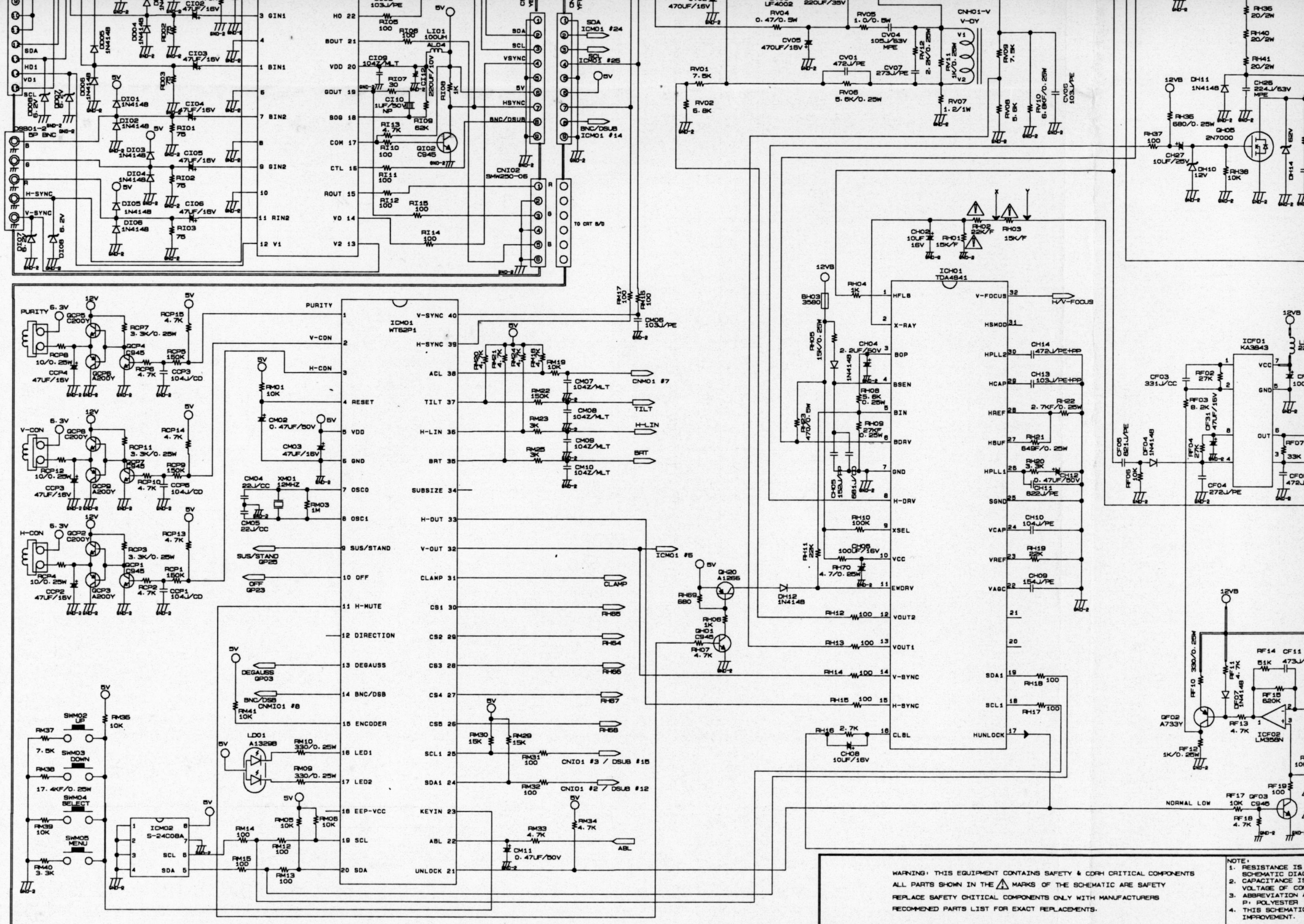

WARNING: THIS EQUIPMENT CONTAINS SAFETY & CORN CRITICAL COMPONENTS
 ALL PARTS SHOWN IN THE Δ MARKS OF THE SCHEMATIC ARE SAFETY
 REPLACE SAFETY CRITICAL COMPONENTS ONLY WITH MANUFACTURERS
 RECOMMENDED PARTS LIST FOR EXACT REPLACEMENTS.

NOTE:
 1. RESISTANCE IS SCHEMATIC DIAG
 2. CAPACITANCE IS VOLTAGE OF CON
 3. ABBREVIATION A P, POLYESTER
 4. THIS SCHEMATIC IMPROVEMENT.

ICM01(MCU) PIN 33

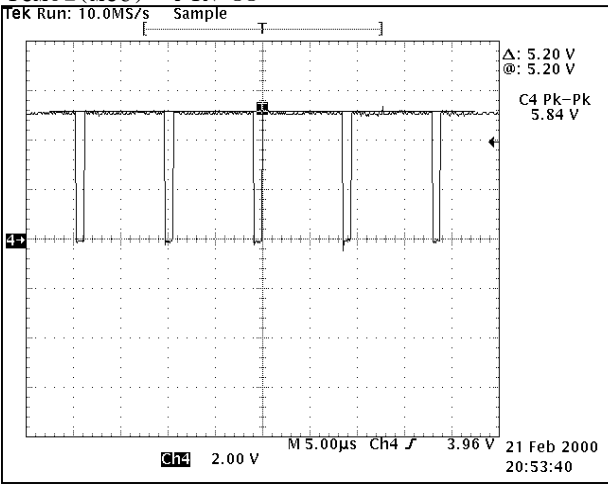

ICM01(MCU) PIN 32

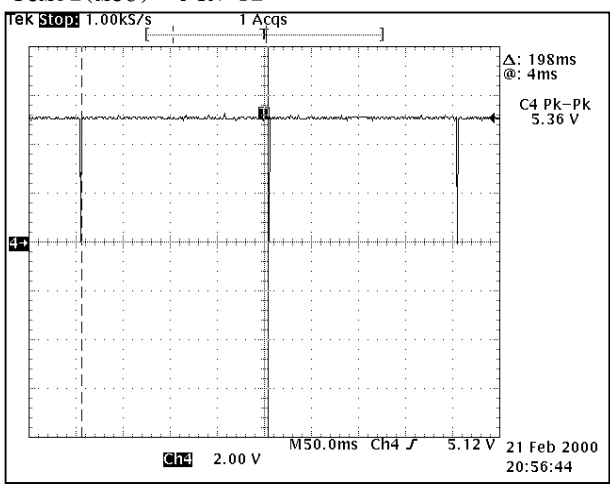

ICH01 PIN 6

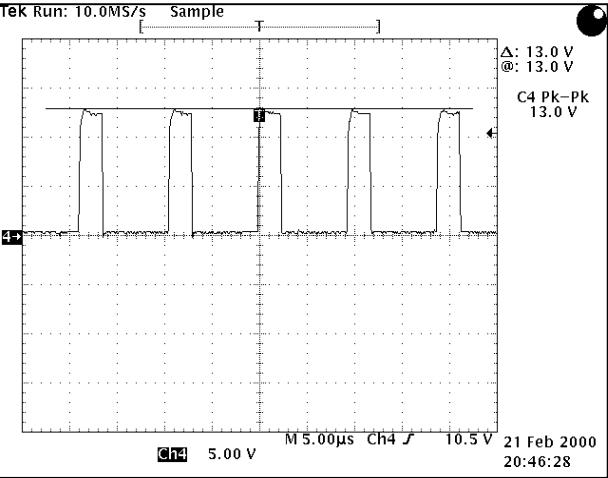

ICH01 PIN 8

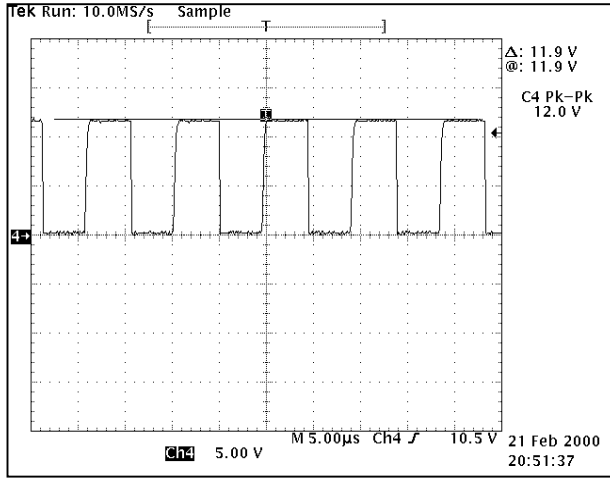

ICH01 PIN 12

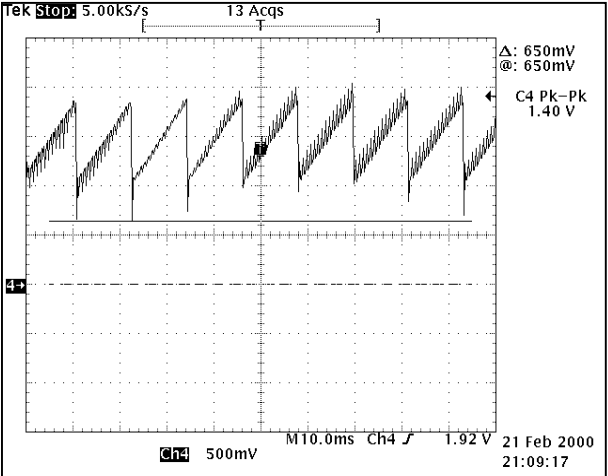

ICH01 PIN 13

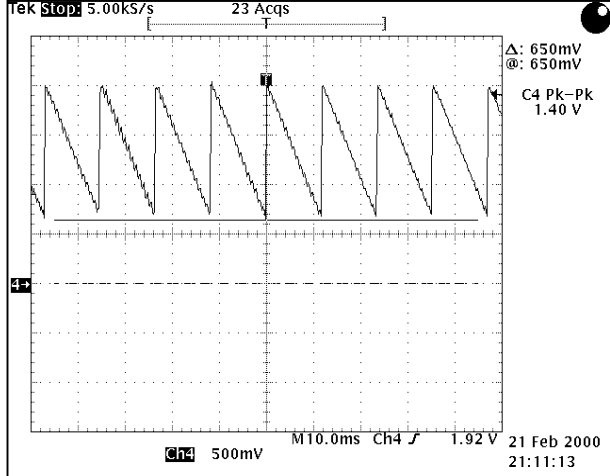

ICH01 PIN 30

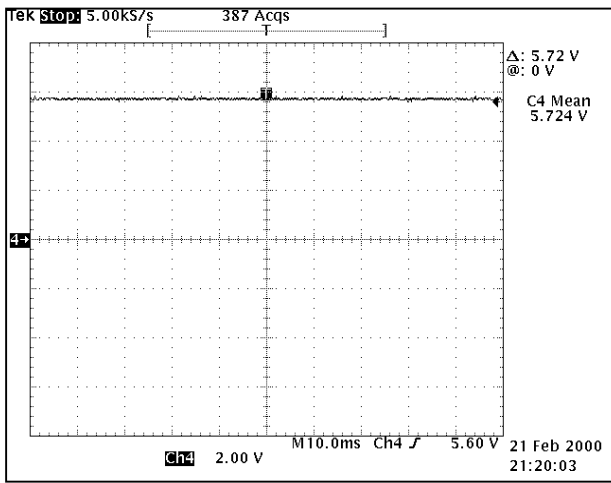

ICH01 PIN 29

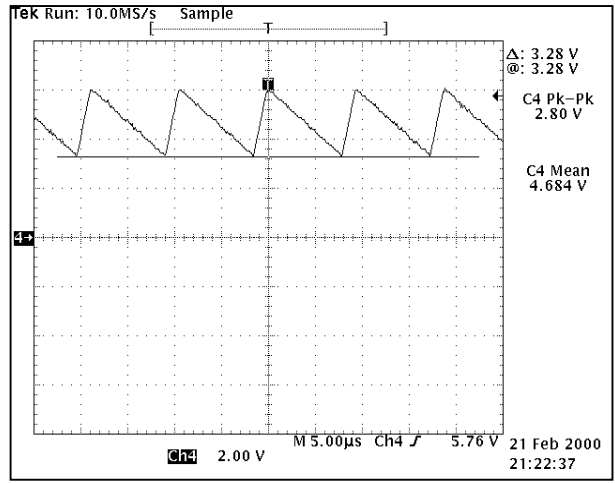

ICV01 PIN 6

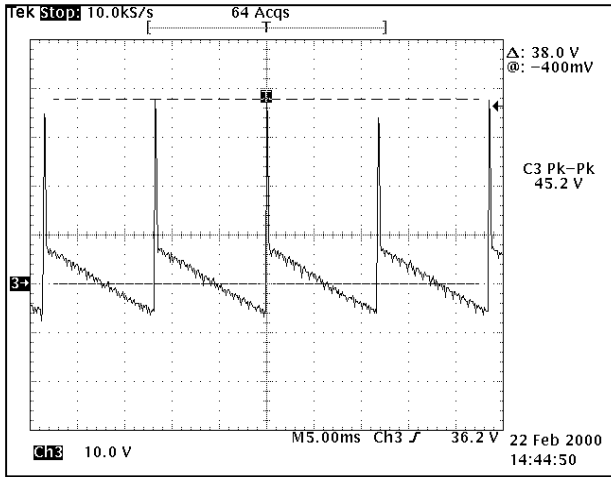

QH04 GATE

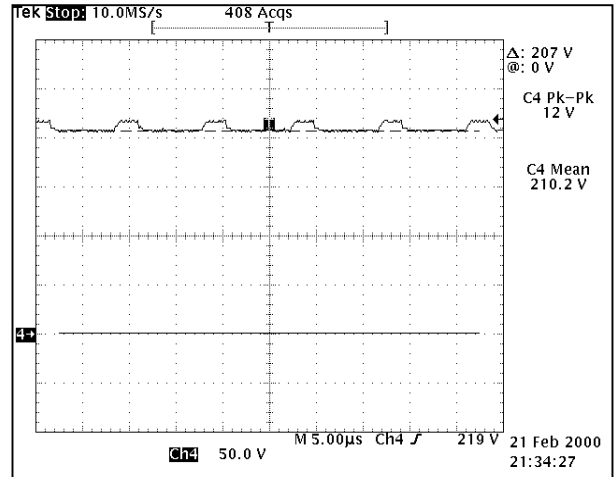

GH04 SOURCE

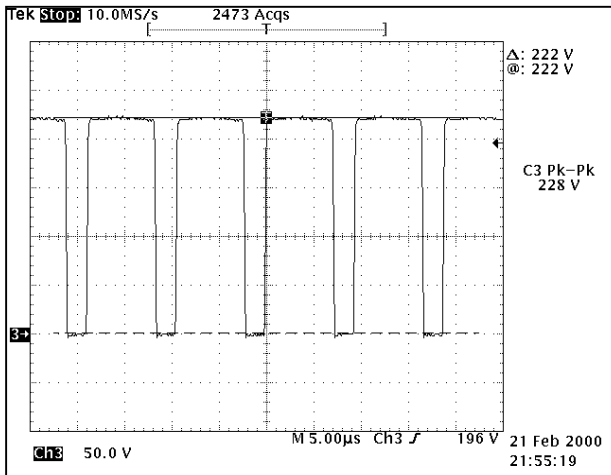

QH05 DRAIN

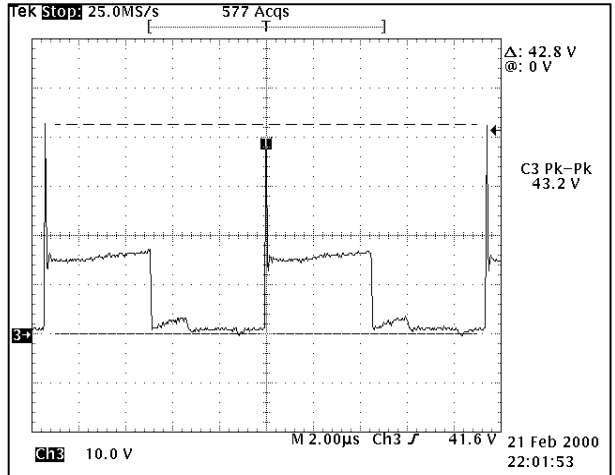

QH06 BASE

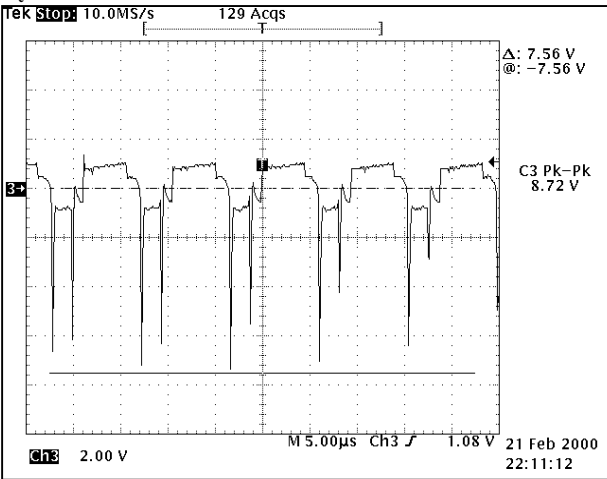

TH02 PIN5 H - DY

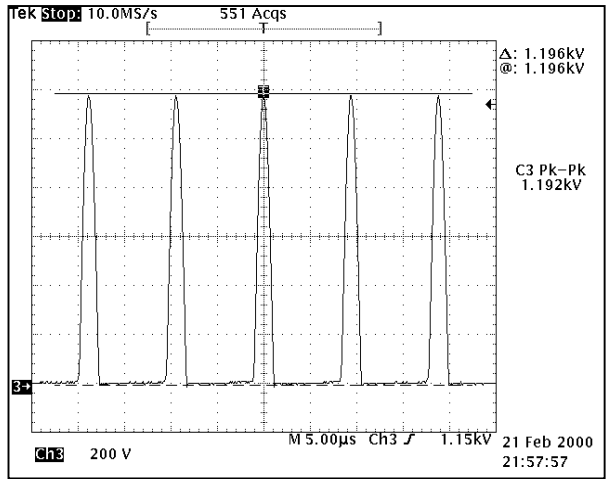

TH03 PIN7 AFC

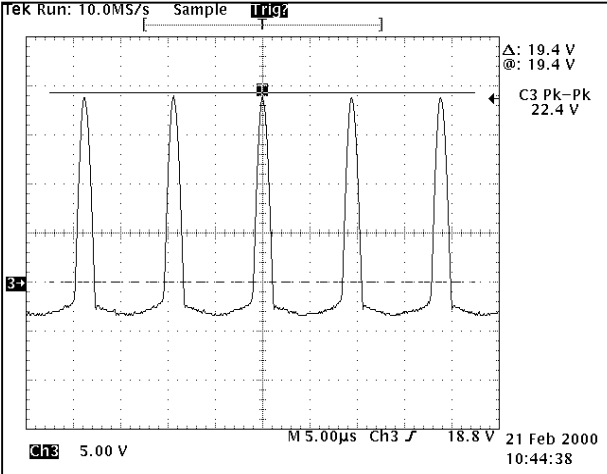

ICF01 PIN6

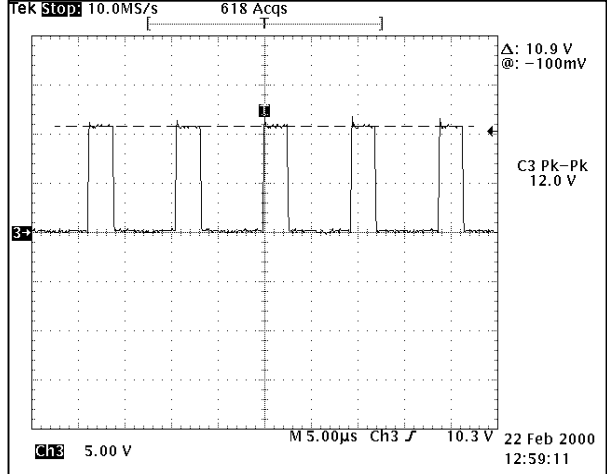

QF01 DRAIN

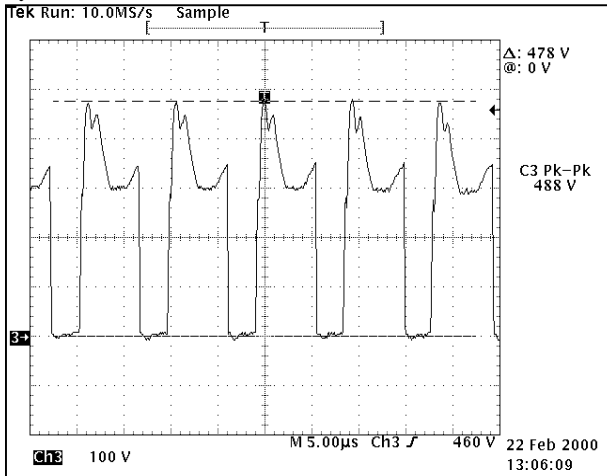

QF06 COLLECTOR

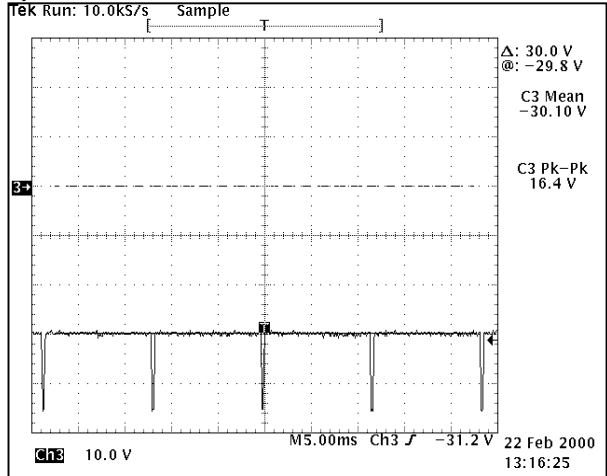

FBT PIN 13

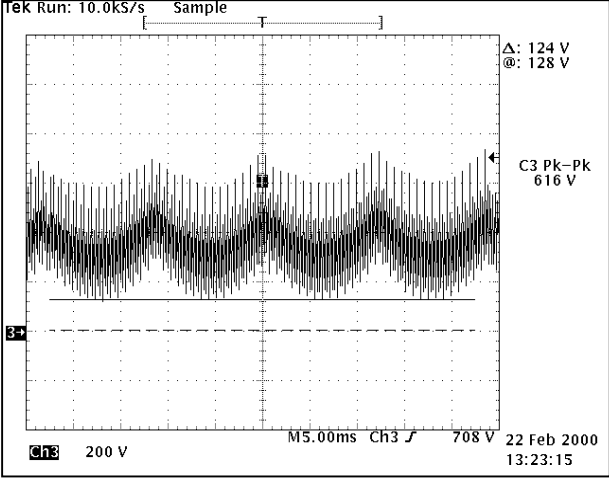

ICP01 PIN 1

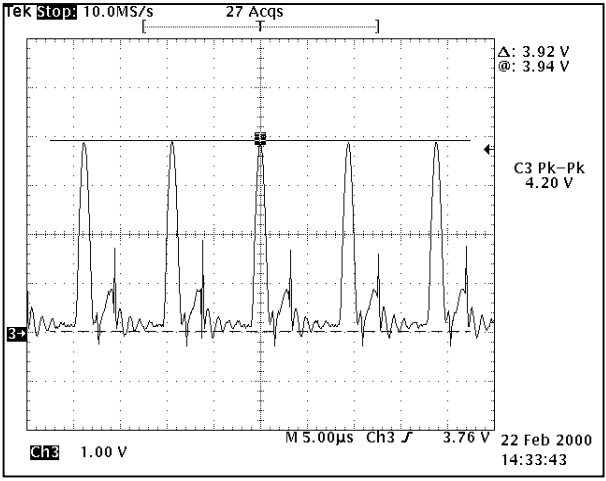

ICP01 PIN 3

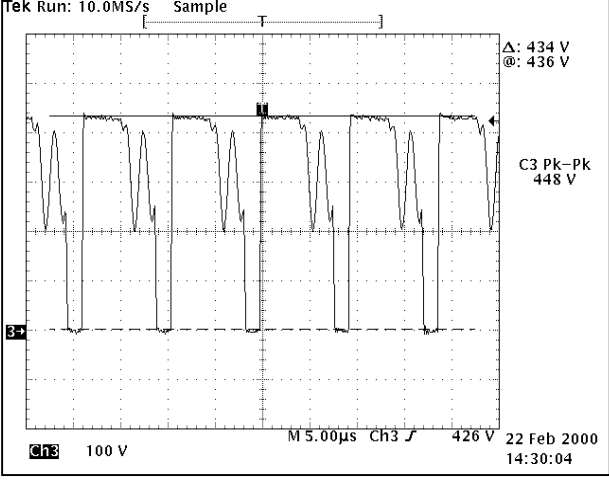

CC01 PIN19 (CH3:Blanking,CH4:cathode)

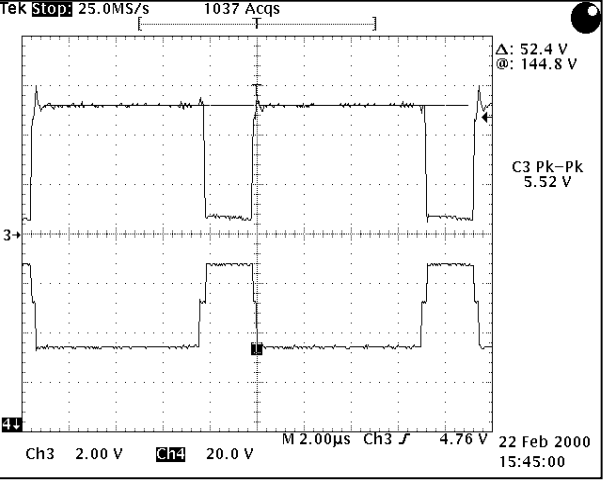

ICC02 PIN 5

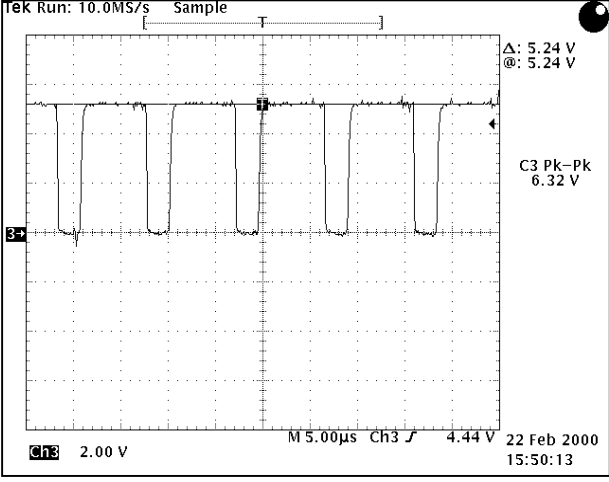

ICC01 PIN18 (CH3:CLAMP,CH4:cathode)

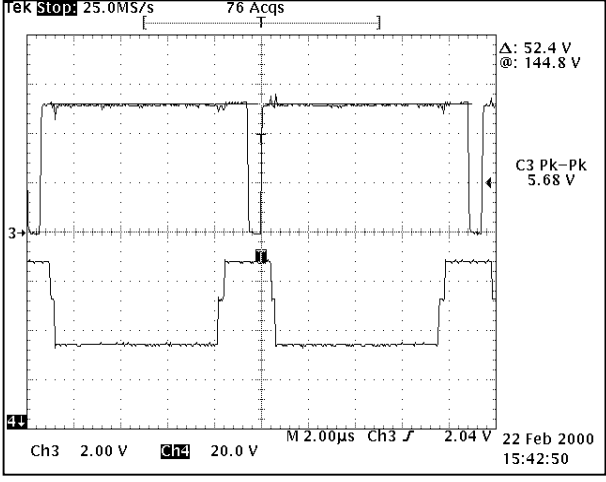

ICCO1 PIN 5,8,10

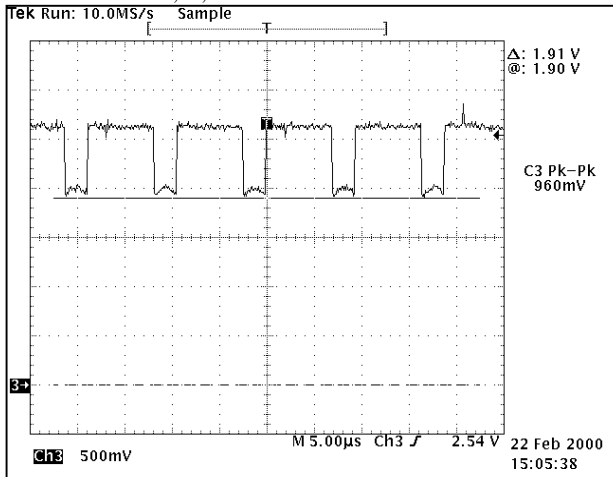

ICCO1 PIN 21,24,26

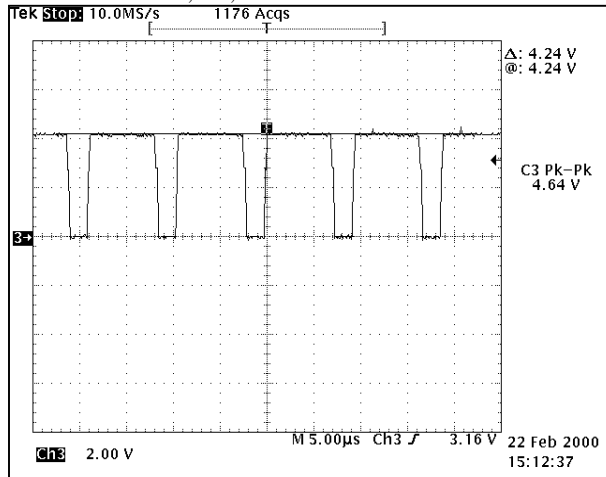

ICCO3 PIN 1,3,5

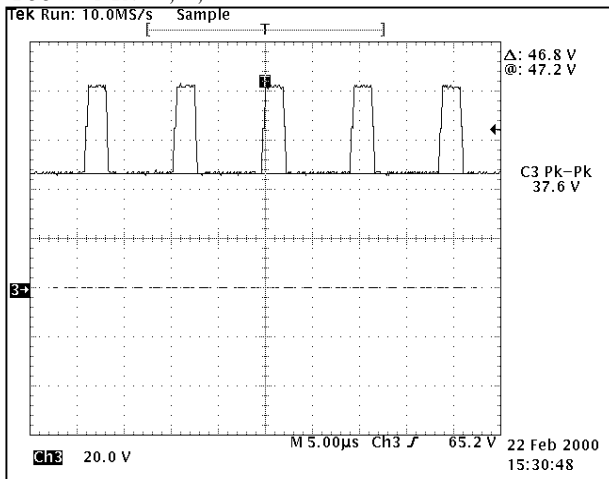

CNC03 R,G,B

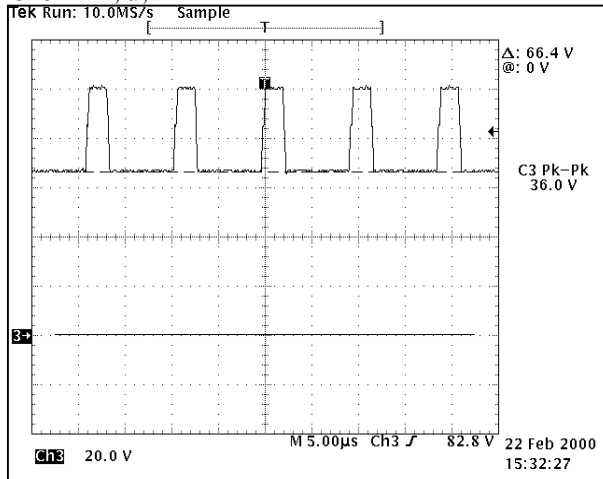

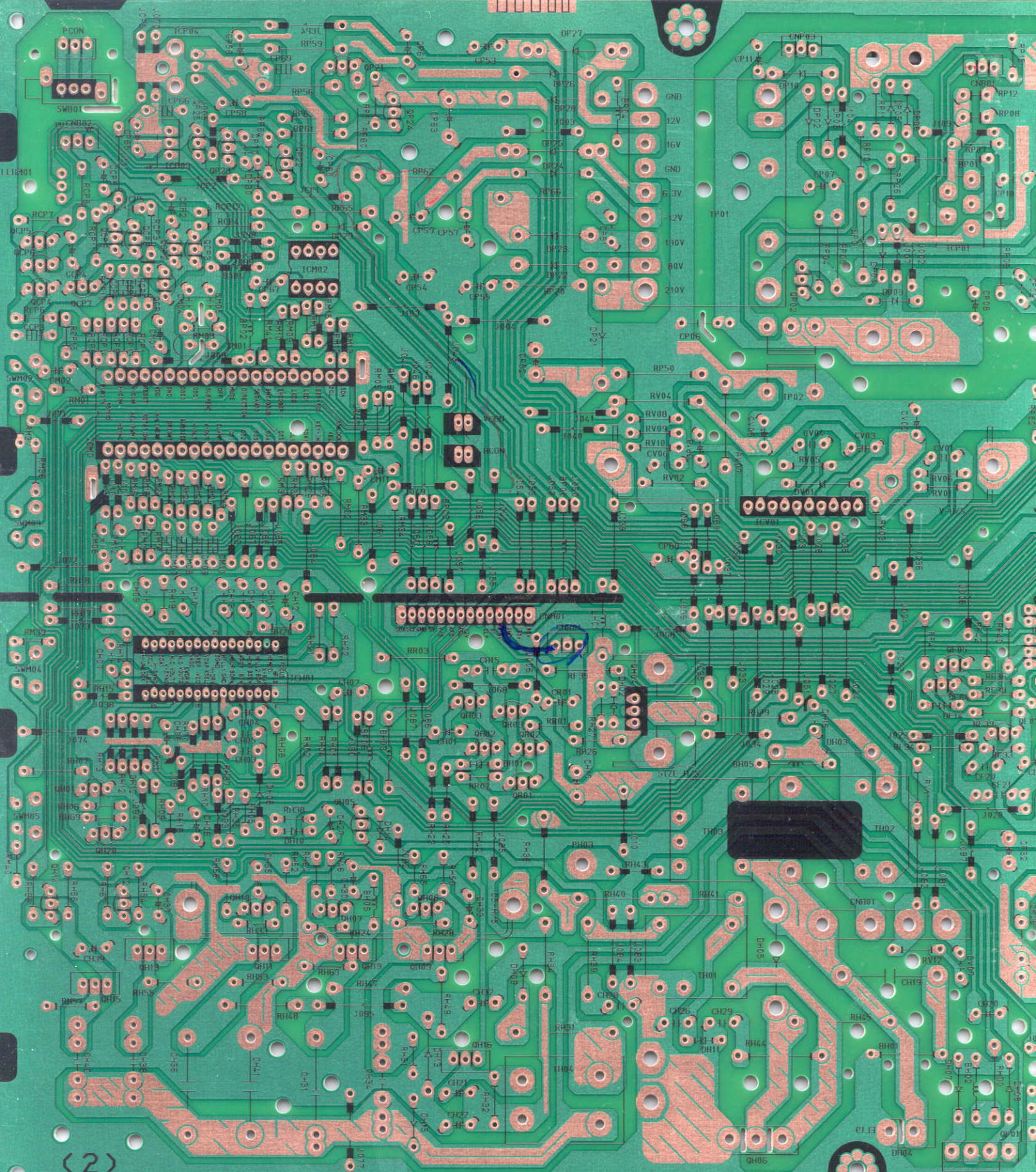

(2)

3040100871 REV:02



SWM5

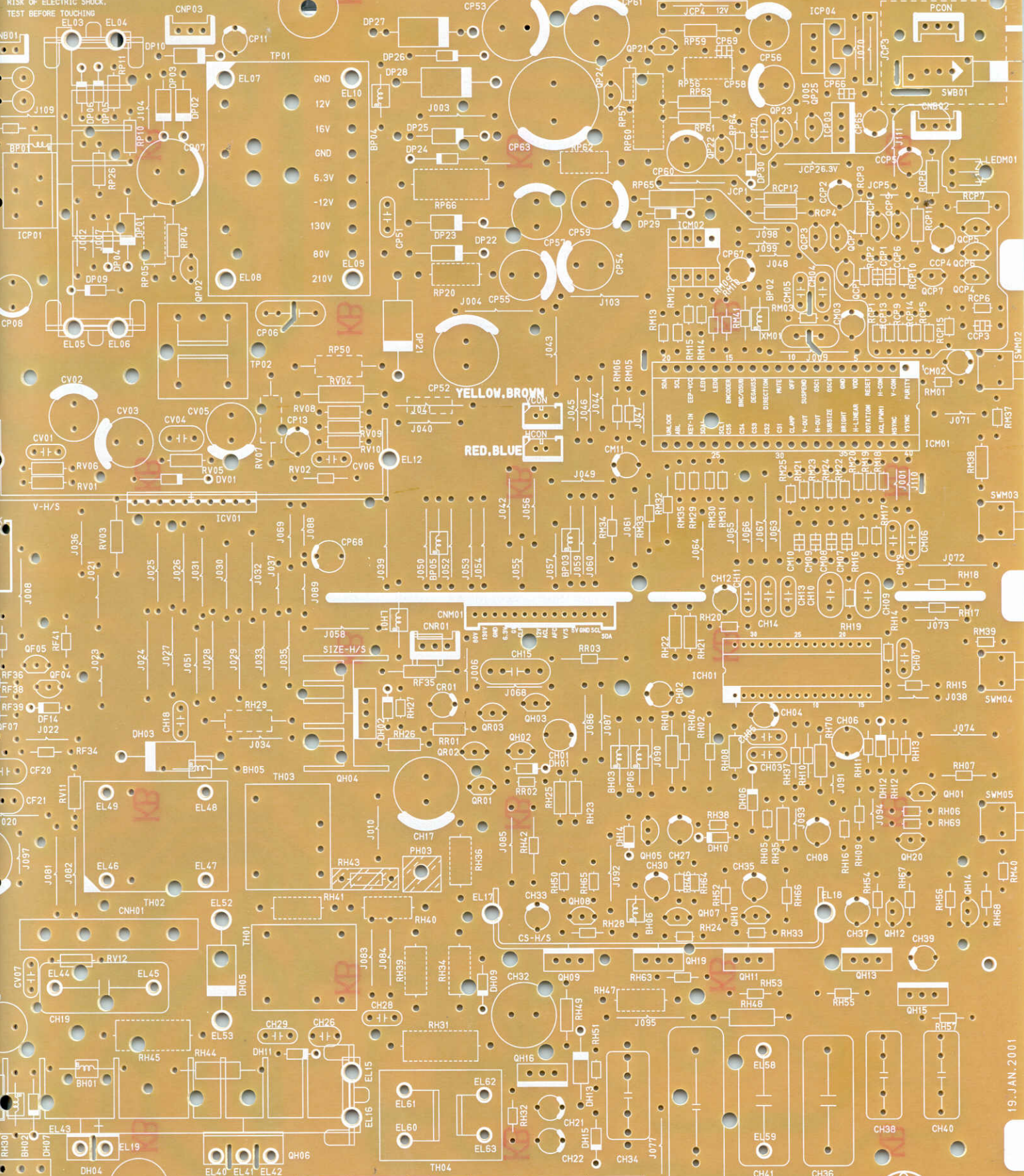

YELLOW, BROWN

RED, BLUE

MODEL	P910+	P990+	F910	G210	OPTION	BNC	DSUB	PUR&CON	PFC
-------	-------	-------	------	------	--------	-----	------	---------	-----

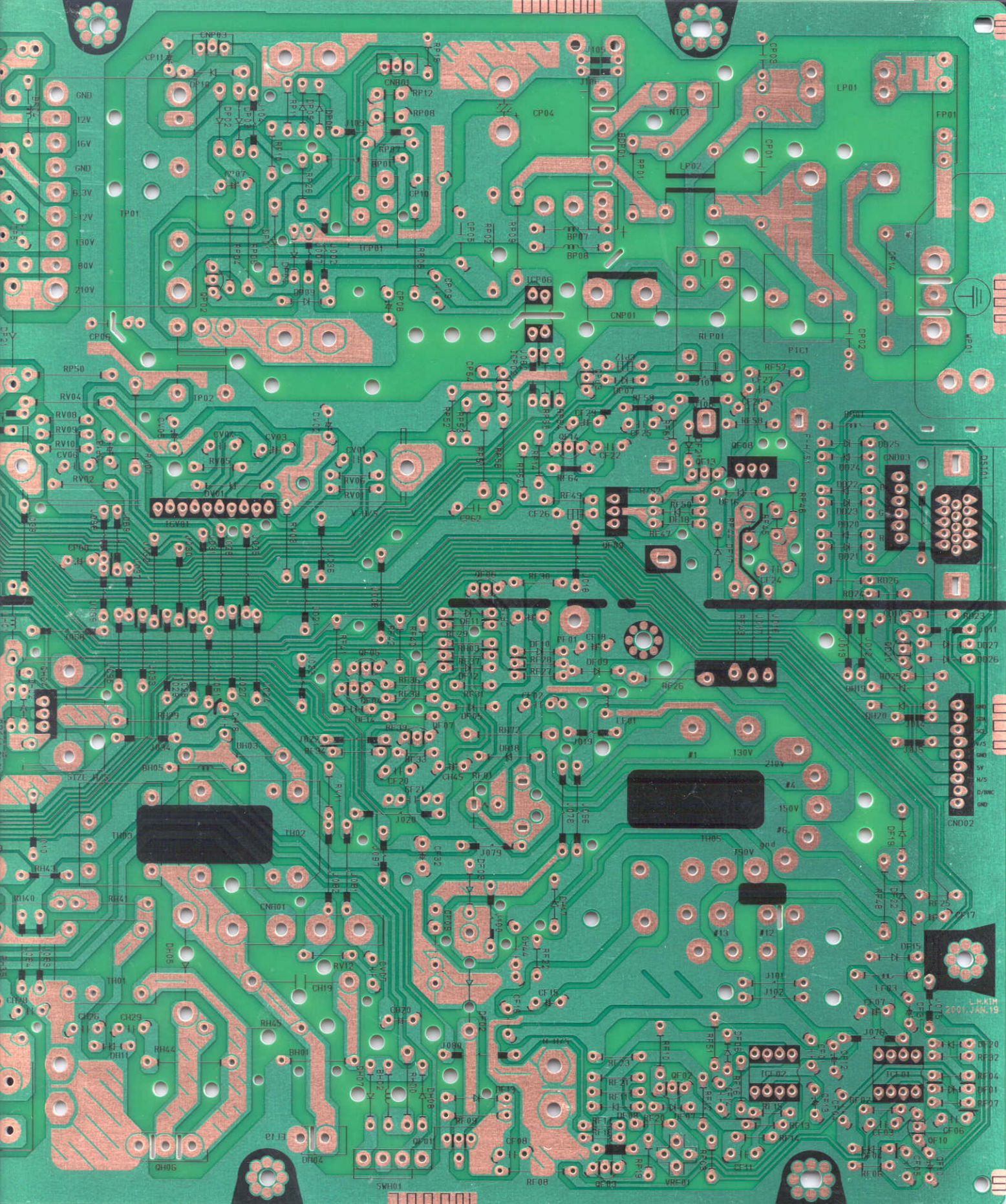

L.H.KIM
2001.JAN.19

R105
R106
R109
R115
R107

CNT02

G
B
G
G
R
G
R

3040100854
REV102

GND
5DA
5CL
V-5
GND
5V
H-5
GND

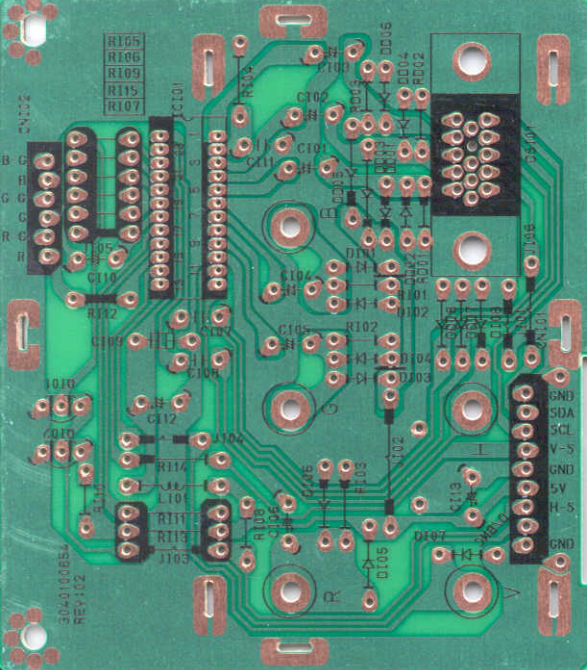

CN102

9
8
7
6
5
4
3
2
1

RT05
RT06
RT09
RI15
RI07

IC101

23 21 19 17 15 13
1 3 5 7 9 11

J105

CI10
RT12

CI07

CI09

CI08

CI12

Q101

Q102

E4208417143
P910+ DSUB & BNC
90K79 FR-1
REV:02

RI10

J103



RT04

CI11

B

CI04

CI05

G

CI06

RI08

R

CI03

RD03

DD06

DD04

DD02

DD01

DD03

DI01

DI02

DI04

DI03

DI08

DI07

DI09

DI10

DI11

DI05

DI06

DI07

J102

RI03

RI02

RI01

RI04

RI05



DS101

J106

1
2
3
4
5
6
7
8
9
10
11

H

CI13

DI10

V

GND
SDA
SCL
V-5
GND
5V
I-5
D/BNC
GND

CN101

J108

J101

DD08

DD07

DD09

DD06

DD05

DD04

DD03

DD02

DD01

DD00

DD09

DD08

DD07

DD06

DD05

DD04

DD03

DD02

DD01

DD00

DD09

DD08

DD07

DD06

DD05

DD04

DD03

DD02

DD01

DD00

DD09

DD08

DD07

DD06

DD05

DD04

DD03

DD02

DD01

DD00

DD09

DD08

DD07

DD06

DD05

DD04

DD03

DD02

DD01

DD00

DD09

DD08

DD07

DD06

DD05

DD04

DD03

DD02

DD01

DD00

DD09

DD08

DD07

DD06

DD05

DD04

DD03

DD02

DD01

DD00

DD09

DD08

DD07

DD06

DD05

DD04

DD03

DD02

DD01

DD00

DD09

DD08

DD07

DD06

DD05

DD04

DD03

DD02

DD01

DD00

DD09

DD08

DD07

DD06

DD05

DD04

DD03

DD02

DD01

DD00

DD09

DD08

DD07

DD06

DD05

DD04

DD03

DD02

DD01

DD00

DD09

DD08

DD07

DD06

DD05

DD04

DD03

DD02

DD01

DD00

DD09

DD08

DD07

DD06

DD05

DD04

DD03

DD02

DD01

DD00

DD09

DD08

DD07

DD06

DD05

DD04

DD03

DD02

DD01

DD00

DD09

DD08

DD07

DD06

DD05

DD04

DD03

DD02

DD01

DD00

DD09

DD08

DD07

DD06

DD05

DD04

DD03

DD02

DD01

DD00

DD09

DD08

DD07

DD06

DD05

DD04

DD03

DD02

DD01

DD00

DD09

DD08

DD07

DD06

DD05

DD04

DD03

DD02

DD01

DD00

DD09

DD08

DD07

DD06

DD05

DD04

DD03

DD02

DD01

DD00

DD09

DD08

DD07

DD06

DD05

DD04

DD03

DD02

DD01

DD00

DD09

DD08

DD07

DD06

DD05

DD04

DD03

DD02

DD01

DD00

DD09

DD08

DD07

DD06

DD05

DD04

DD03

DD02

DD01

DD00

DD09

DD08

DD07

DD06

DD05

DD04

DD03

DD02

DD01

DD00

DD09

DD08

DD07

DD06

DD05

DD04

DD03

DD02

DD01

DD00

DD09

DD08

DD07

DD06

DD05

DD04

DD03

DD02

DD01

DD00

DD09

DD08

DD07

HYUNDAI REG CIRCUIT

QF1

H/S

DF1

RF9

TF1

CONF2

3040100870
REV:02

RF4

CF7

CONF3

RF3

RF2

RF5

ICF1

CF3

CF4

CF5

RF6

CF1

230

DF2

RF1

RF8

TF10

TF11

CF02

RF12

CONF1

RF7

+

+

YUNDAI PFC CIRCUIT CONF3+

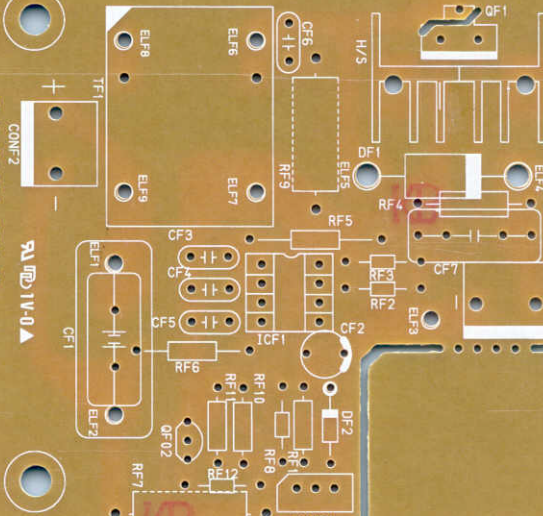

3040100870 REV:02 75X81.5

9A 1V-0

VP

Exploded View

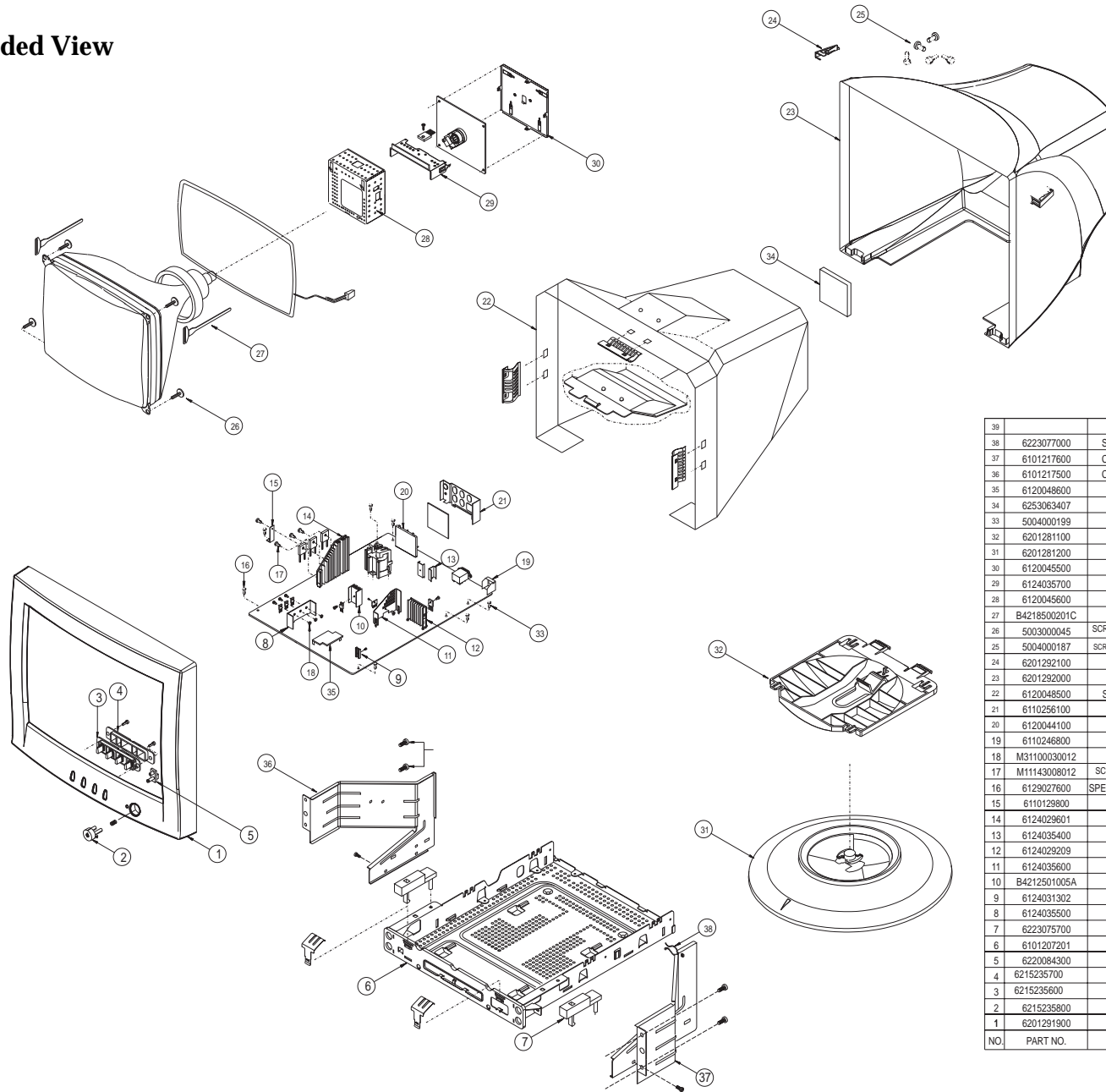

39	6223077000	SUPPORT TWIST LOCK	NYLON	1	
38	6101217600	CHASSIS RIGHT ASSY	SPTT T=1.0	1	
37	6101217500	CHASSIS LEFT ASSY	SPTT T=1.0	1	
36	6120048600	MCU COVER	ET T=0.3	1	
35	6253063407	PAD.SPONGE(T=15.0)	SOFT POLYURETHANE FOAM	1	
34	5004000199	SCR.T.T.WAL 3*8	MSZPC	1	
33	6201281100	SWIVEL UPPER	HIPS	1	
32	6201281200	SWIVEL BASE	HIPS	1	
31	6120045500	SHLD-PL. FENCE CRT	SPTT T=0.3	1	
30	6124035700	H-SINK VIDEO	AI050P T=1.2	1	
29	6120045600	FENCE SHIELD CRT COVER	SPTT T=0.3	1	
28	B4218500201C	RETAINER COIL		2	
27	5003000045	SCREW.TR3(BIN(+)) 5x28 MSZPC	MSZPC	4	
26	5004000187	SCREW.TT2(BIN(+)) 4x14 MSZPC	MSZPC	11	
25	6201292100	CAP COVER L/R	ABS	1	
24	6201292000	COVER REAR	ABS	1	
23	6120048500	SHLD-CASE COVER ASSY	AI050P T=0.3	1	
22	6110256100	BRK REAR ASSY	SECC T=1.0	1	
21	6120044100	BRKT BNC COVER	SPTT T=0.5	1	
20	6110246800	BRKT POWER	SPTT T=0.5	1	
19	M31100030012	NUT HEX, 6N1-3	MSZPC	6	
18	M11143008012	SCREW.BIN(H) 3x6 MSZPC		8	
17	6129027600	SPECIAL.T.T.W(+)) 3*8	MSZPC	10	
16	6110129800	BRKT HS	SECC T=1.0	1	
15	6124029601	HEAT SINK H.O.T	A6063S	1	
14	6124035400	HEAT SINK F	SECC T=1.0	2	
13	6124029209	HEAT/S POWER FET A	A6063S	1	
12	6124035600	HEAT SINK V	AI050P T=1.2	1	
11	B4212501005A	HEAT SINK POWER	A6063S	1	
10	6124031302	HEAT SINK TR C	A6063S	1	
9	6124035500	HEAT SINK CS	AI050P T=1.2	2	
8	6223075700	BRKT MOLD	ABS	2	
7	6101207201	CHASSIS MAIN ASSY	SECC T=1.0	2	
6	6220084300	LENS LED POWER	LUCKY PMMA IF 850	1	
5	6215235700	KNOB TACT B	ABS 94 HB	1	
4	6215235800	KNOB TACT A	ABS 94 HB	1	
3	6215235800	KNOB POWER	ABS 94 HB	1	
2	6201291900	COVER FRONT	ABS	1	
1					
NO.	PART NO.	PART NAME	DESCRIPTION	QTY	품 명