

# NEC

**MODELS**    **MultiSync V720**  
                  **MultiSync V721**  
                  **Diamond Scan 71**  
**(Model No. N0701 Series)**

COLOR MONITOR

## **SERVICE MANUAL**

---

---

**Better Service**  
**Better Reputation**  
**Better Profit**

---

---



## WARNING

The SERVICE PERSONNEL should have the appropriate technical training knowledge and experience necessary to :

- Be familiar with specialized test equipment, and
- Be careful to follow all safety procedures associated with high voltage CRT circuit designs to minimize danger to themselves and their coworkers.

To avoid electrical chocks, this equipment should be used with an appropriate power cord and be connected only to a properly grounded AC outlet

This equipment utilized a micro-gap power switch. Turn off the monitor by first pushing the front panel power switch. Next, remove the power cord from the AC outlet.

To prevent fire or shock hazards, do not expose this unit to rain or moisture



This symbol warns the personnel that un-insulated voltage within the unit may have sufficient magnitude to cause electric shock.



This symbol alerts the personnel that important literature concerning the operation and maintenance of this unit has been included. Therefore, it should be read carefully in order to avoid any problems.



## PRODUCT SAFETY CAUTION

1. When parts replacement is required for servicing, always use the manufacturer's specified replacement.
2. Comply with all caution and safety-related notes on the product display chassis and picture tube.
3. When replacing the component, always be certain that all the components are put back in the place.
4. When servicing display monitor unit, it is required that the provided lead dress is used in the high voltage circuit area.
5. It is also recommended that shatter proof goggles are worn, when removing, installing and handling the picture tube. People not equipped with the proper precautionary measures mentioned should keep the picture tube away from body while handling.
6. As for a connector, pick and extract housing with fingers properly since a disconnection and improper contacts may occur, when wires of the connector are led.
7. Use a proper screwdriver. If you use screwdriver that does not fit, you may damage the screws.

# CONTENTS

	<b>Page No.</b>
PRECAUTIONS .....	1
SPECIFICATIONS .....	3
PIN ADJUSTMENT TABLE .....	4
CONTROLS .....	5
ON-SCREEN MANAGER(OSM) .....	7
SERIAL NUMBER INFORMATION .....	12
DISASSEMBLY .....	13
ADJUSTMENT PROCEDURES .....	16
WRITE AND INSPECTION FOR PLUG AND PLAY COMMUNICATION .....	28
TROUBLE SHOOTING .....	31
CIRCUIT DESCRIPTION .....	39
REPLACEMENT PARTS LIST .....	73
1) MultiSync V720 Parts List .....	73
2) MultiSync V721 Different List .....	94
3) Diamond Scan 71 Different List .....	96
BLOCK DIAGRAMS .....	98
SCHEMATIC DIAGRAMS .....	99
1) Video Board .....	99
2) Main Board .....	100

# 1 Precautions

Follow these safety and servicing precautions to prevent damage and to protect against potential hazards such as electrical shock and X-rays.

## 1.1 Safety Precautions

### 1-1-1 Warnings

1. For safety purpose, do not attempt to modify the circuit board, and always disconnect the AC power before performing servicing on the monitor.
2. Operation of the monitor outside its cabinet or with the cover removed involves the risk of shock hazard. Repair work on the monitor should only be attempted by service personnel who are thoroughly familiar with all necessary safety precautions and procedures for working on high voltage equipment.
3. Do not lift the CRT by the neck. After completely discharging the high voltage anode, handle the CRT only when wearing shatterproof goggles. Try to keep the CRT away from the body during handling.
4. High voltage should always be kept at the rated value, no higher. Only when high voltage is excessive are X-rays capable of penetrating the shell of the CRT. Operation at high voltages may also cause failure of the CRT or high voltage circuitry.
5. The CRT is especially constructed to limit X-ray emission to 0.5mR/HR at 300 microamperes anode current. To ensure continued X-ray protection, replace the CRT with only the same or equivalent type as the original, and adjust the anode's voltage to the designated maximum rating, never to exceed.

### 1-1-2 Safety Checks

Before returning the monitor to the user, perform the following safety checks:

1. Inspect to make certain that each lead dress is not pinched or that hardware is not lodged between the chassis and other metal parts in the monitor.
2. Inspect all protective devices such as nonmetallic control knobs, insulating materials, cabinet backs, adjustment and compartment covers or shields, isolation resistor-capacitor networks, mechanical insulators, etc.
3. AC Leakage Current Check

Always perform the AC Leakage Current Check on the exposed metal parts, including metal cabinets, screwheads and control shafts, as follows:

- a) Plug the AC line cord directly into a rated AC outlet. Do not use an isolation transformer during the check.
- b) Use an AC voltmeter with at least 5000 ohms per volt sensitivity as follows:  
Connect a 1500 ohms, 10 watt resistor paralleled by a 0.15uF AC capacitor in series with all exposed metal cabinet parts and a known earth ground, such as electrical conduct or electrical ground connected to earth ground, as shown in the Figure 1-1. Measure the AC voltage across the combination of resistor and capacitor.

Figure 1-1. Set Up For AC Leakage Current Check

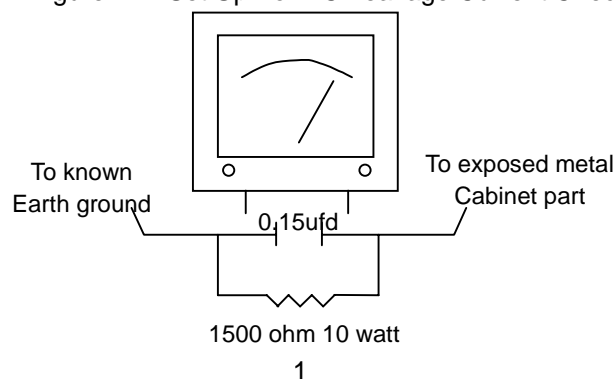

- c) Reverse the AC plug at the AC outlet and repeat the steps for AC voltage measurements for each exposed metal part.
- d) Voltage reading must not exceed 0.3 volts RMS, equivalent to 0.2 milliampere AC. Any value exceeding this limits ill constitute a potential shock hazard and must be corrected immediately

### **1-1-3 Product Safety Notices**

Many electrical and mechanical parts in this chassis have special safety-related characteristics which are often not evident from visual inspection. The protection afforded by them may not be obtained by replacing them with components rated for higher voltage, wattage, etc. Before replacing any of these components, consult the Recommended Spare Parts List given at the end of this manual. Any of the replacements that do not provide the same safety characteristics may result in shock, fire, X-ray emission or other hazards.

### **1.2 Servicing Precautions**

**Warning:** An electrolytic capacitor installed with the wrong polarity might explode.

**Caution:** Before performing servicing covered by this service manual, read and follow the Safety Precautions section of this manual.

**Note:** If unforeseen conflict between the following servicing precautions and of the safety precautions, always follow the safety precautions

1. Follow closely the servicing precautions printed on the monitor cabinet and chassis.
2. Always unplug the AC power cord from the AC power source before removing or installing any component or assembly, disconnection PCB plugs or connectors and connecting a test component in parallel with a capacitor.
3. When replacing parts or circuit boards, clamp the lead wires around the unit before soldering.
4. When replacing a high wattage resistor (>0.5W metal oxide film resistor) in the circuit board, keep the resistor about 1 cm (1/2 inch) away from the circuit board.
5. Keep wires away from the high voltage or high temperature components.
6. Keep wires in their original positions so as to minimize interference.
7. Always connect a test instrument's ground lead to the instrument chassis ground before connecting the positive lead; always remove the instrument's ground lead last.

## SPECIFICATION

Monitor Specifications	N0701 Monitor	Notes
Picture Tube	Diagonal: 43cm(17inch) Viewable Image Size: 40.6cm(16.0inch) Radius: 1210mm	90° deflection, 0.28mm grille pitch, medium short persistence phosphor, aperture grille CRT, multi-layered, anti- static screen coating, dark screen.
Input Signal	Video: ANALOG 0.7Vp-p/75 Ohms Sync: Separate sync. TTL Level Horizontal sync. Positive/ Negative Vertical sync. Positive/Negative	
Display Colors	Analog input: Unlimited number of Colors	Depends on display card used.
Synchronization Range	Horizontal: 31 kHz to 70 kHz Vertical: 55 Hz to 120 Hz	Automatically Automatically
Resolutions Supported Resolution based on horizontal and vertical frequencies only	640 × 480 @ 60 to 120 Hz 800 × 600 @ 55 to 110 Hz 832 × 624 @ 55 to 106 Hz 1024 × 768 @ 55 to 87 Hz ..... 1152 × 870 @ 55 to 77 Hz 1280 × 1024 @ 55 to 66 Hz	Some systems may not support all modes listed. NEC cites recommended resolution at 85 Hz for optimal display performance.
Active Display Area (Factory Setting)	Horizontal: 310mm Vertical: 232mm	Dependent upon signal timing used, and does not include border area.
Active Display Area (Full Scan)	325mm 243mm	Dependent upon signal timing used, and does not include border area.
Power Supply	AC 100 - 240V, 50 - 60Hz	
Current Rating	1.5A @ 100 - 240V	
Dimensions	403(W) × 420(H) × 418(D) mm	
Weight (Net)	15.5 kg	
Environmental Considerations		
	Operating Temperature: 0° C to + 35° C Humidity: 30% to 80% Altitude: 0 to 3000 m	
	Storage Temperature: -20° C to + 60° C Humidity: 10% to 90% Altitude: 0 to 13700 m	

NOTE: Technical specifications are subject to change without notice.

# PIN ASSIGNMENT

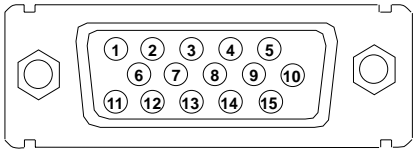

PIN NO.	Mini D-SUB-15P
1	RED
2	GREEN
3	BLUE
4	GROUND
5	GROUND
6	RED GROUND
7	GREEN GROUND
8	BLUE GROUND
9	NO PIN
10	GROUND
11	GROUND
12	SDA
13	H.SYNC.
14	V.SYNC.
15	SCL

## CONTROLS

- ① "SELECT": To display OSM windows, mode changes, or activate the degaussing or OSM window color selection.
- ② CONTROL BUTTON (-,+): Without OSM — Adjust the contrast.  
With OSM — Select icon and adjust.
- ③ "RESET": Return the adjustment item to the factory setting.
- ④ Power indicator LED: The LED indicate Power management state.
- ⑤ POWER SWITCH: Push/push to turn the monitor on and off.
- ⑥ Power input: To connect with the power cord.
- ⑦ Signal input with the captive cable: To connect with personal computers' analogue RGB output.

### MultiSync V720

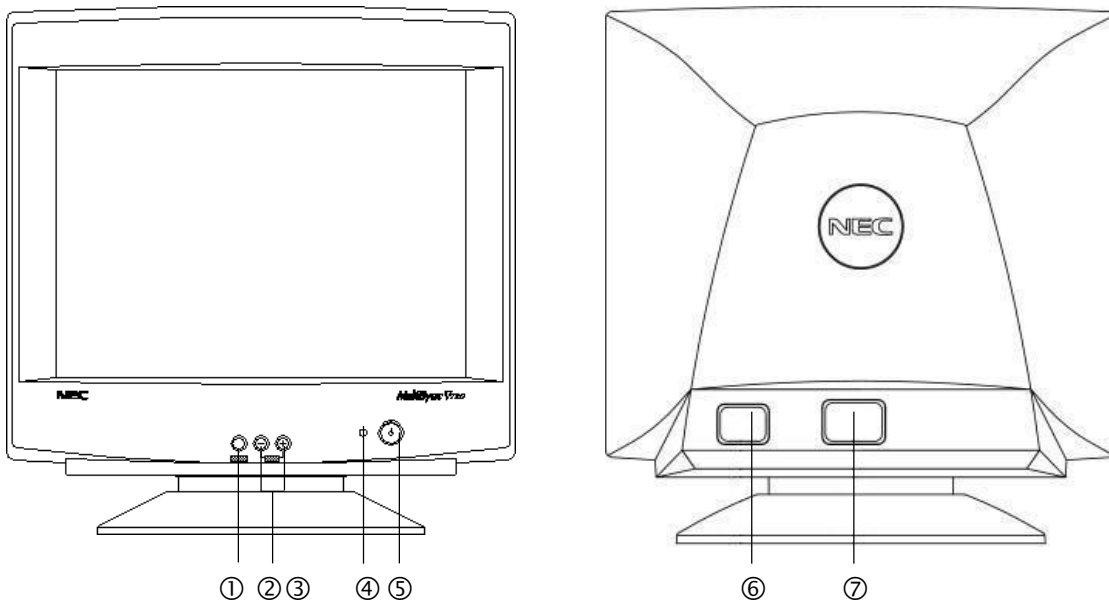

### MultiSync V721

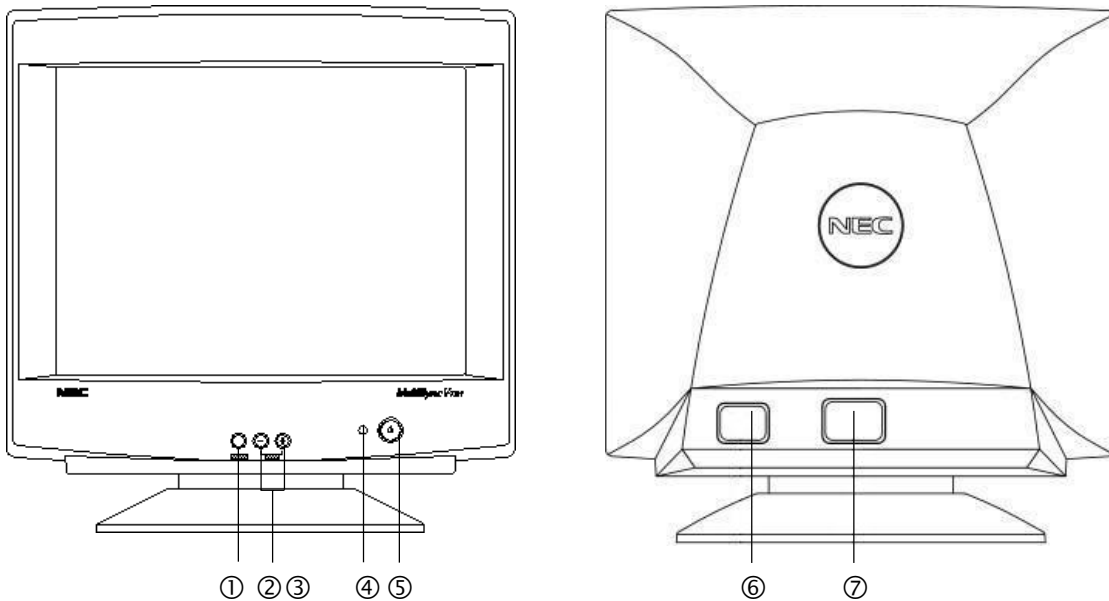



**Diamand Scan 71**

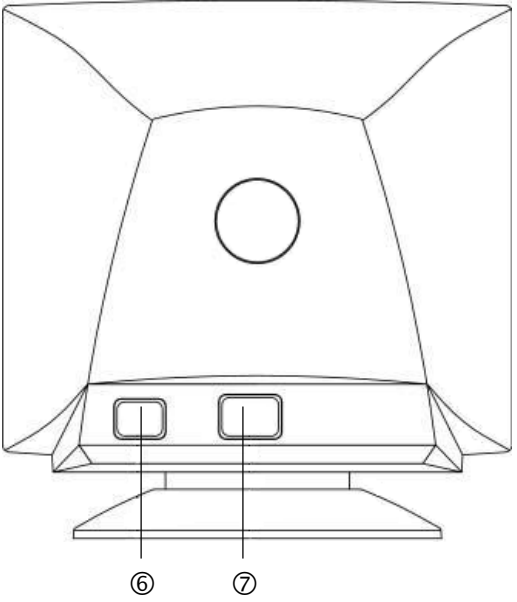
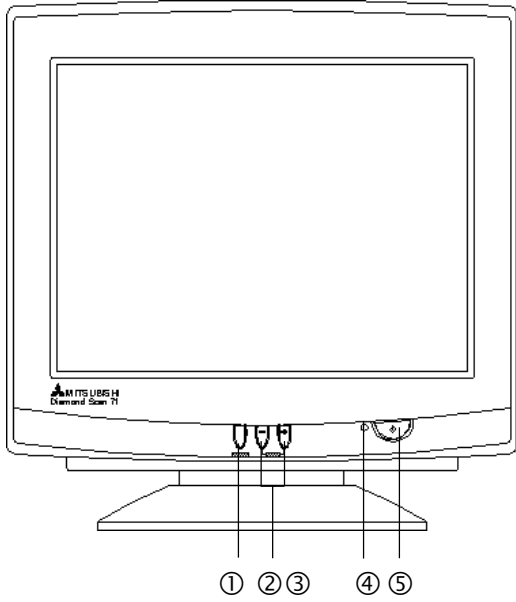

## OSD OPERATION

### FUNCTION VALUE ADJUSTMENT

If OSD off, press UP key to increase Contrast value,  
press DOWN key to decrease Contrast value.  
press SELECT key to display OSD and Brightness icon is active (Fig. 1)



Fig. 1

Press UP key or DOWN key to select icon right or left and the selected icon display red color  
If selected icon is DAC out, press SELECT key will display DAC value bar (fig 2)



Fig. 2

User can press UP key or DOWN key to adjust DAC value.  
Press SELECT key to close DAV value bar and UP key or DOWN key to select the other icon.

### SPECIAL FUNCTION OPERATION

#### 1. Degauss Active

If selected icon is degauss icon, press SELECT key to activate degauss (Fig. 3).



Fig. 3

## 2. Color Temperature Select

If selected icon is 9300/7500/6500/user color icon, press SELECT key to select Color Temperature for 9300, 7500, 6500 or user defined (Fig 4 – 7).



Fig. 4



Fig. 5



Fig. 6



Fig. 7

## 3. OSD Color Select

If OSD icon is selected, press SELECT key to change OSD color, there are three kinds of OSD color can be selected (Fig. 8 – 10).



Fig. 8



Fig.9



Fig. 10

Background	white
Action icon	red
Normal icon	black
Value bar	blue

Background	blue
Action icon	red
Normal icon	white
Value bar	yellow

Background	black
Action icon	red
Normal icon	white
Value bar	green

#### 4. SYNC OSD Display

If EXIT icon is selected, press SELECT key to close OSD menu and then display sync information for 2 sec. This sync information will not be close until release SELECT key (Fig. 11).



Fig. 11

#### 5. Factory mode

Press SELECT key + UP key and power on, system enter factory mode.

OSD will display "FA" to indicate in factory mode (Fig. 12 – 13).

Operation of factory mode is same as normal mode except below 2 condition:

- a. adjustment value is saved to user and factory area.
- b. R, G, B value are saved to current color temperature.



Fig. 12



Fig. 13

#### 6. OSD Move Mode

Press DOWN key and power on, system enter OSD move mode, user can move OSD display position in this mode.

Press SELECT key then OSD display following figure (Fig. 14) and only 3 icons OSD H-position / OSD V-position / ESC can be selected.



Fig. 14

## Function explanation



Brightness: Adjusts the overall image and background screen brightness.



Contrast: Adjusts the image brightness in relation to the background.

(Contrast control is also effective with “-, +” button even through OSM window is not existing.)

**R**

**Red Color Control:** Adjust the red contrast of the display.

**G**

**Green Color Control:** Adjust the green contrast of the display.

**B**

**Blue Color Control:** Adjust the blue contrast of the display.



Horizontal position: Moves the image horizontally left or right.



Vertical position: Moves the image vertically up or down.



Horizontal size: Increases or decreases the horizontal size of the image.



Vertical size: Increases or decreases the vertical size of the image.



Pincushion/Barrel: Increases or decreases the curvature of the sides either inward or outward.



Trapezoid: Increases or decreases the bottom of the screen to be the same as the top.



Parallelogram: Increases or decreases the tilt of the sides either to the left or right.



Bow (Pincushion Balance): Increases or decreases the curvature of the sides either left or right.



Rotation: Rotate the image.



**Degauss:** Select the degauss icon on “Icon select window” and push “SELECT”

button. It will eliminate the stray magnetic field and correct the scan the electron beam, and will affect the purity, focus, convergence.

Caution: Allow a minimum interval of 20 minutes to elapse between uses of the degauss function.

**9300K** Color Temperature: Select the Color Temperature icon on “Icon Select Window” and push “SELECT” button.

It can be switched the different color Temperature.



**OSD:** There are 3 background colors (Blue, Black, and white).

These can be selected by “SELECT” button after the selection of “OSD” on “Icon select window”.

**exit EXIT:** To exit the OSM window. Select EXIT on “Icon select window”. Then push “SELECT” button to exit OSM window.

**Note:** If you do not push buttons over 10 seconds in OSM condition, the window will automatically disappear.

# SERIAL NUMBER INFORMATION

Refer to the serial number information shown below.

Ex.) SERIAL NUMBER LABEL

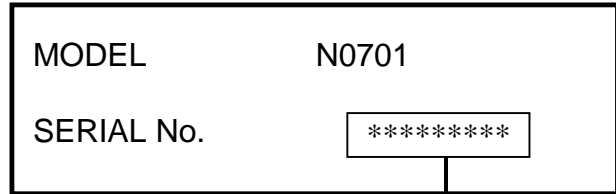

0 Y 0 0 0 0 1 Y □

Manufactured Year : \_\_\_\_\_  
( Last digit )

Manufactured Month : \_\_\_\_\_  
January to September 1 to 9  
October X  
November Y  
December Z

00001 ~ on ward  
(Start from 00001 ~ when  
month is changed.)

Factory mark : \_\_\_\_\_

NPG CHINA "Y"

Control Code ... E  
Control Code ... A ( only  
DiamondScan 71)

## DISASSEMBLY

### Tilt / swivel base fixing, removing

#### Fixing

This product consists of the MultiSync monitor and the tilt / swivel base.

When fixing the tilt / swivel base to the MultiSync monitor, please follow the steps below.

- Push the six hooks of the tilt / swivel base into the six holes at the bottom of the MultiSync monitor.
- Then slide the tilt / swivel base forward.
- Then the latch above the tilt / swivel base engages it is secure.

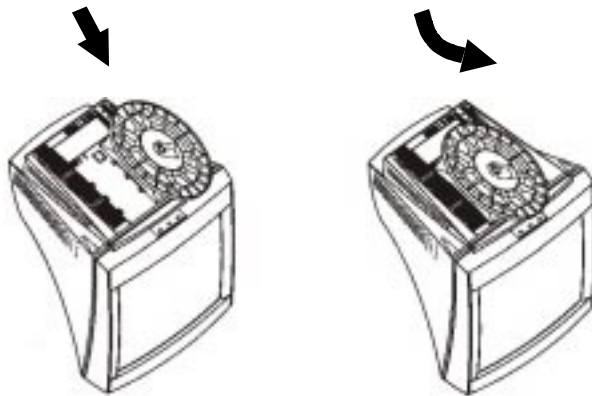

#### Removing

Please removing the tilt / swivel base when transporting for repair.

- Push down the latch of the MultiSync monitor and pull out the tilt / swivel base.
- Slide backward the tilt / swivel base from the front of the MultiSync monitor.
- Pull out the tilt / swivel base from the holes of the MultiSync monitor.

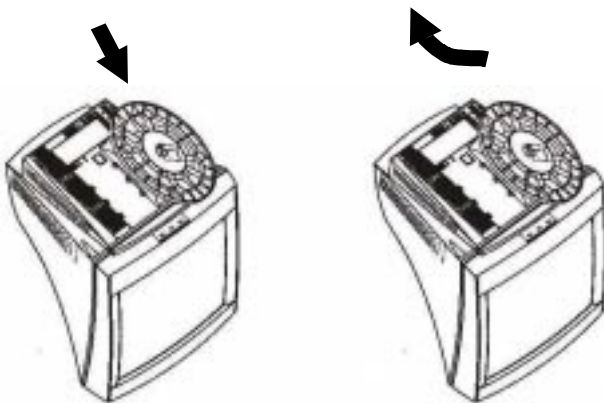



**Cabinet Back**



- 1. Turn the monitor CRT face down on a clean static free surface to prevent scratching CRT face.
- 2. Remove the screw "b".
- 3. Raise the signal cable vicinity of a cabinet back and lightly hit part (figure 1 reference) of a top of the cabinet back and remove the cabinet back.

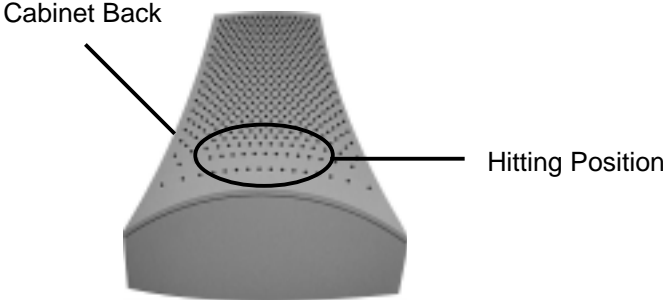
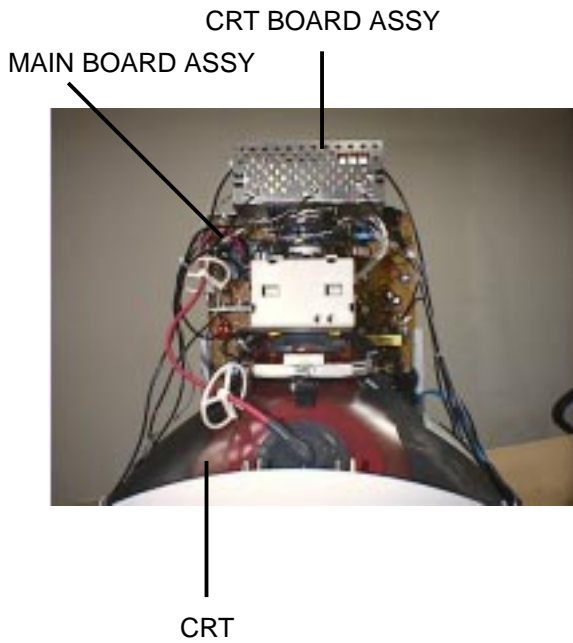

Fig. 1

## MAIN BOARD and CRT BOARD



1. Unsolder the GND wire from MAIN BOARD ASSY
2. Disconnect the connector "P201", "P202", "S204" and "S205" from the CRT BOARD ASSY.
3. Disconnect the CRT BOARD ASSY from the CRT
4. Disconnect the connector "S301" and "P102" from the MAIN BOARD ASSY.
5. Remove the Anode Cap from the CRT.

**NOTE:**

- Carefully discharge the CRT anode by shorting it to ground before removing Anode Cap.
6. Lift up the MAIN BOARD ASSY from the Cabinet Front ASSY.

# ADJUSTMENT SPECIFICATIONS

## TABLE OF CONTENTS

### Page

(1) Adjustment & Inspection Tools .....	17
(2) Timing Table .....	17
(3) Definition for Normal Condition .....	17
(4) Hot Key Operation .....	17
(5) B+ Adjustment .....	18
(6) X-ray Test .....	18
(7) H. V. Adjustment .....	18
(8) H-Raster Center Adjustment .....	18
(9) Pre-Adjustment .....	18
(10) White Balance Adjustment .....	18
(A) Setting .....	18
(B) Cut Off Adjustment .....	18
(C) White Balance Adjustment (Factory Auto Adjustment) .....	19
(D) Maximum Brightness Adjustment .....	19
(11) Focus Adjustment .....	19
(12) Convergence Adjust .....	19
(13) Power Saving Function Inspection .....	20
(14) Geometry Adjustment .....	20
(15) DCC 1/2B Writing and Inspection .....	20
(16) Shipping Condition .....	20
(17) Adjustment Magnetic Field .....	20
(18) Timing Sheet .....	21

### Reference

Distortion Adjustment .....	25
Inspection of PnP communication and Writing EDID to EEPROM and inspection of PnP communication .....	28

## N0701 Adjustment Specifications

Ver. 1.1  
2000,10,27

(1) Adjustment & Inspection Tools:

- |                                   |                                   |
|-----------------------------------|-----------------------------------|
| (A) Color Analyzer                | (B) Signal Generator CHAROMA 2135 |
| (C) Multi Meter                   | (D) Hi-Voltage Probe              |
| (E) Convergence Meter             | (F) Demagnetizer                  |
| (G) Power Meter                   | (H) Automatic Alignment System    |
| (I) DDC write & inspection system |                                   |

(2) TIMING TABLE(Factory Mode -20 MODES)

MODE	RESOLUTION	H-SYNC EREQ.	V-SYNC FREQ	H . POLARITY	V . POLARITY
1	VGA350	31.5KHz	70Hz	+	-
2	VGA400	31.5kHz	70Hz	-	+
3	VGA480	31.5KHz	60Hz	-	-
4	MAC 35K	35.0KHz	66Hz	-	-
5	800*600(56)	35.2KHz	56Hz	+	+
6	8514A	35.5KHz	87Hz	+	+
7	640*480(75)	37.5KHz	75Hz	-	-
8	EVGA400	37.8KHz	84Hz	-	+
9	800*600(60)	37.8KHz	60Hz	+	+
10	640*480	43.3KHz	85Hz	-	-
11	800*600(75)	46.8KHz	75Hz	+	+
12	1024*768(60)	48.3KHz	60Hz	-	-
13	MAC 49K	49.7KHz	74Hz	-	-
14	800*600(85)	53.6KHz	85Hz	+	+
15	1024*768(70)	56.4KHz	70Hz	-	-
16	1024*768(75)	60.0KHz	75Hz	+	+
17	640*480(120)	63.7KHz	120Hz	-	-
18	1280*1024(60)	64.0KHz	60Hz	+	+
19	800*600(100)	64.0KHz	100Hz	+	+
20	1024*768(85)	68.6KHz	85Hz	+	+

(3) Definition for Normal Condition

- (A) Input AC Voltage 110V/60HZ.
- (B) Warm up time 30 minutes.
- (C) Crosshatch Reverse Pattern.
- (D) ALL VR's Adjust Center Position.
- (E) Color temperature setting: 9300K
- (F) OSD I-CON [R], [G], [B] gain control bar center position in Factory Mode

(4) Hot Key Operation

- (A) Factory Mode: SELECT Key + UP (+) Key if pressed when the power SW on.
- (B) OSD Position Control Mode: DOWN (-) Key if pressed when the power SW on.

(5) B+ Adjustment

- (A) MODE: No. 12.
- (B) Pattern: Full white. (Brightness just cut off)
- (C) Adjust VR101 to make the cathode of D112 has 13.6V.
- (D) Check other power source should be 78  $\pm$ 0.2V, 6.2V  $\pm$ 0.3V, 53.5V  $\pm$ 1.5V, -11.5V  $\pm$ 0.5V.

(6) X-RAY Test

- (A) Mode: No.12
- (B) Pattern: Normal Crosshatch (Brightness just cut off)
- (C) Test
  1. Use Hi-Voltage probe
  2. Adjust VR102 until X-RAY protector is operated, then check the protection voltage should be 29.5KV or less.
  3. After X-RAY protection test, turn back the VR102 position to center.

(7) H. V. Adjustment

- (A) Mode: No. 12
- (B) Pattern: Full White(Brightness just cut off)
- (C) Adjust VR102 to make the cathode of D114 has 117V (LG CRT), 118V (Samsung CRT), 103V (TOSHIBA CRT), 117V (Matsushita CRT).
- (D) Check the high voltage is 25.8kV  $\pm$ 1kV.

(8) H-Raster Center Adjustment

- (A) Mode: No. 18
- (B) Pattern: Crosshatch Reverse
- (C) Adjust the Brightness Control that the background can be visible.
- (D) Change SW301 position to make the mostly near center background position.

(9) Mode 12 Pre-Adjustment

- (A) Mode: No. 12
- (B) Pattern: Crosshatch
- (C) Enter to Factory mode. Adjust H-phase, V-center, H-size, V-size, Pincushion, Trapezoid, Bow, Parallelogram, and rotation to make Picture Position Center and Picture Size 310\*232mm.

(10) White Balance Adjustment

- (A) Setting
  - Enter Factory Mode,
  - Mode: No. 12, Pattern: Full White.
  - Warm up 30 min.
  - Make External Degauss.
- (B) Cut Off Adjustment
  1. Select the color Mode 9300K
  2. Cut Off Adjustment: Video Signal Off (0.vp-p), Bright Control set to Mex., Adjust VR301 (VR307 for Toshiba CRT), at the Brightness 1~1.5FL. (3.4~5.1 cd/m<sup>2</sup>)

3. Adjust VR210, VR230 and VR250 to make X=283, Y=297, with readjusting VR301 (VR307 for Toshiba CRT) to keep the brightness between 1~1.5FL (3.4~5.1 cd/m<sup>2</sup>).

(C) White Balance Adjustment (Factory Auto Adjustment)

1.9300K (Select the color Mode 9300K)

- 1) 50\*50mm Green block Pattern, Brightness Control set to Max, Contrast Control set to Max, Adjust [G] gain control to Y=45FL. (154 cd/m<sup>2</sup>)
- 2) Change Pattern to Full White, Brightness control set to Min.
- 3) Adjust [R] gain control, [B] gain control to X=283, Y=297 at the contrast control is adjusted 15FL (52cd/m<sup>2</sup>).
- 4) Check the color tracking shall be X=283  $\pm$ 15, Y=297  $\pm$ 15 between Y=5~25FT-L (17~86cd/m<sup>2</sup>) condition.

2.7500K (Select the color Mode 7500K)

- 1) 50\*50mm Green block Pattern, Brightness Control set to Max, Contrast Control set to Max, Adjust [G] gain control to Y=42FL. (144 cd/m<sup>2</sup>)
- 2) Change Pattern to Full White, Brightness control set to Min.
- 3) Adjust [R] gain control, [B] gain control to X=300, Y=315 at the contrast control is adjusted 15FL (52cd/m<sup>2</sup>).

3. 6500K (Select the color Mode 6500K)

- 1) 50\*50mm Green block Pattern, Brightness Control set to Max, Contrast Control set to Max, Adjust [G] gain control to Y=39FL. (134 cd/m<sup>2</sup>)
- 2) Change Pattern to Full White, Brightness control set to Min.
- 3) Adjust [R] gain control, [B] gain control to X=315, Y=325 at the contrast control is adjusted 15FL (52cd/m<sup>2</sup>).

(D) Maximum brightness Adjustment

1. Brightness control set to Max., contrast control set to Max
2. Adjust VR306 to Y=31FL(105cd/m<sup>2</sup>)

(11) Focus Adjustment

(A) Mode: No.16

(B) Pattern: Full 'o' (4dots hole) Pattern, Brightness just cut off, Contrast maximum.

(C) Adjust Focus VR that 'o' mark shall be clearly at 1/4 poit of the diagonal line.

(12) Convergence Adjust

(A) Mode: No. 12

(B) Pattern: Crosshatch.

(C) Use the convergence meter to check whether the convergence is within spec.  
Adjust the CPC Magnet to make the convergence within spec.

(13) Power Saving Function Inspection

(A) Mode: No. 12

(B) Pattern: Any Pattern

(C) Inspection

1. It should be into power off Mode when the both horizontal sync and vertical sync are disable after 4 sec. Check the LED color "Orange" and the power consumption must be less then 5W.
2. The picture should be recovered readable within 3 seconds when the both horizontal sync and vertical sync are enable. Check the LED color "Green".

(14) Geometry Adjustment (Factory Auto Alignment)

(A) Enter to the Factory Mode.

(B) Adjust H-size, V-size, H-phase, V-phase, Pincushion, and Trapezoid for all preset signals.

(C) Adjustment data are automatically stored into the factory-preset memory after 1 sec.

Note: for the factory auto alignment, Mode No. 2,3,7,9,10,11,12,14,15,16,17, 18, 19,20 shall be adjusted. Other modes can be used the calculated average value.

(15) DDC 1/2B Writing and Inspection

(A) Mode: Any Mode, Pattern: Any Pattern.

(B) Connect the MICON Tech. DDC Read/Write System.

(C) Scan bar code label and apply serial NO. to EDID Data.

(16) Setting Before Shipment

Color Temp 9300K

OSD Back Ground: Blue

OSD Position: Center of the screen

Contrast: Maximum

Brightness: Preset (Background should be disappeared)

Self test pattern: Crosshatch (Select the "P2" in the Factory Mode)

(17) Adjustment Magnetic Field

(A) For Northern Hemisphere Model

Vertical: +40uT, Horizontal: +/-0uT (Neutral).

(B) For Southern Hemisphere Model

Vertical: +40uT, Horizontal: +/-0uT (Neutral).

## (18) TIMING SHEET for N0501 / N0701

Preset Mode No.	1	2	3	4	5	6
Signal Name	VGA350	VGA400	VGA480	MACII (35K)	800*600 (56)	8514/A XGA
Resolution	640*350	640*400	640*480	640*480	800*600	1024*768
Dot Clock (MHz)	25.175	28.322	25.175	30.240	36.000	44.900
fh (kHz)	31.47	31.47	31.47	35.00	35.16	35.52
fv (Hz)	70.09	70.09	59.94	66.67	56.25	86.96
Total (dot)	800	800	800	864	1024	1264
(uS)	31.78	31.78	31.78	28.57	28.44	28.15
Disp (dot)	640	640	640	640	800	1024
(uS)	25.42	25.42	25.42	21.16	22.22	22.81
Front (dot)	16	16	16	64	24	8
(uS)	0.64	0.64	0.64	2.12	0.67	0.18
Sync Pulse (dot)	96	96	96	64	72	176
(uS)	3.18	3.81	3.81	2.12	2.00	3.92
Back (dot)	48	48	48	96	128	56
(uS)	1.91	1.91	1.91	3.17	3.56	1.25
Total (H)	449	449	525	525	625	408.5
(mS)	14.268	14.268	16.683	15.000	17.778	11.500
Disp (H)	350	400	480	480	600	384
(mS)	11.122	12.711	15.253	13.714	17.067	10.810
Front (H)	37	12	10	3	1	0
(mS)	1.176	0.381	0.318	0.086	0.028	0.000
Sync Pulse (H)	2	2	2	3	2	4
(mS)	0.064	0.064	0.064	0.086	0.057	0.113
Back (H)	60	35	33	39	22	20
(mS)	1.907	1.112	1.049	1.114	0.626	0.563
Interlace	NON	NON	NON	NON	NON	YES
Polarity (H/V)	POS/NEG	NEG/POS	NEG/NEG	NEG/NEG	POS/POS	POS/POS
Composite Sync				NEG		
Composite Video						
Character Font	7*9	7*9	7*9	7*9	7*9	7*9
Serration	OFF	OFF	OFF	ON	OFF	OFF
EQP	OFF	OFF	OFF	OFF	OFF	OFF



Preset Mode No.	7	8	9	10	11	12
Signal Name	640*480 (75)	EVGA400 (VESA)	800*600 (60)	640*480 (85)	800*600 (75)	10*7(60) (VESA)
Resolution	640*480	640*400	800*600	640*480	800*600	1024*768
Dot Clock (MHz)	31.500	31.5000	40.000	36.000	49.500	65.000
fh (kHz)	37.50	37.86	37.88	43.27	46.88	48.36
fv (Hz)	75.00	84.13	60.32	85.01	75.00	60.00
Total (dot)	840	832	1056	832	1056	1344
(uS)	26.67	26.41	26.40	23.11	21.33	20.68
Disp (dot)	640	640	800	640	800	1024
(uS)	20.32	20.32	20.00	17.78	16.16	15.75
Front (dot)	16	24	40	56	16	24
(uS)	0.51	0.76	1.00	1.56	0.32	0.37
Sync Pulse (dot)	64	40	128	56	80	136
(uS)	2.03	1.27	3.20	1.56	1.62	2.09
Back (dot)	120	128	88	80	160	160
(uS)	3.81	4.06	2.20	2.22	3.23	2.46
Total (H)	500	450	628	509	625	806
(mS)	13.333	11.886	16.579	11.76	13.333	16.666
Disp (H)	480	400	600	480	600	768
(mS)	12.800	10.565	15.840	11.093	12.800	15.880
Front (H)	1	9	1	1	1	3
(mS)	0.027	0.238	0.026	0.023	0.021	0.062
Sync Pulse (H)	3	3	4	3	3	6
(mS)	0.080	0.079	0.106	0.069	0.064	0.124
Back (H)	16	38	23	25	21	29
(mS)	0.427	1.004	0.607	0.578	0.448	0.600
Interlace	NON	NON	NON	NON	NON	NON
Polarity (H/V)	NEG/NEG	NEG/POS	POS/POS	NEG/NEG	POS/POS	NEG/NEG
Composite Sync						
Composite Video						
Character Font	7*9	7*9	7*9	7*9	7*9	7*9
Serration	OFF	OFF	OFF	OFF	OFF	OFF
EQP	OFF	OFF	OFF	OFF	OFF	OFF

Preset Mode No.	13	14	15	16	17	18
Signal Name	MACII (49.7K)	800*600 (85)	10*7(70) (VESA)	10*7(75) (VESA)	640*480 (120)	12*10(60) (VESA)
Resolution	832*624	800*600	1024*768	1024*768	640*480	1280*1024
Dot Clock (MHz)	57.286	56.250	75.000	78.750	55.00	108.000
fh (kHz)	49.73	53.67	56.48	60.02	63.66	63.98
fv (Hz)	74.55	85.06	70.07	75.03	120.11	60.02
Total (dot)	1152	1048	1328	1312	864	1688
(uS)	20.11	18.63	17.71	16.66	15.71	15.63
Disp (dot)	832	800	1024	1024	640	1280
(uS)	14.52	14.22	13.65	13.00	11.645	11.85
Front (dot)	32	32	24	16	32	48
(uS)	0.56	0.57	0.32	0.20	0.582	0.44
Sync Pulse (dot)	64	64	136	96	96	112
(uS)	1.12	1.14	1.81	1.22	1.745	1.04
Back (dot)	224	152	144	176	96	248
(uS)	3.91	2.70	1.92	2.23	1.745	2.30
Total (H)	667	631	806	800	530	1066
(mS)	13.413	11.756	14.272	13.328	8.325	16.661
Disp (H)	624	600	768	768	480	1024
(mS)	12.548	11.179	13.599	12.795	7.540	16.005
Front (H)	1	1	3	1	8	1
(mS)	0.020	0.019	0.053	0.017	0.126	0.016
Sync Pulse (H)	3	3	6	3	6	3
(mS)	0.060	0.056	0.106	0.050	0.094	0.047
Back (H)	39	27	29	28	36	38
(mS)	0.784	0.503	0.513	0.466	0.566	0.594
Interlace	NON	NON	NON	NON	NON	NON
Polarity (H/V)	NEG/NEG	POS/POS	NEG/NEG	POS/POS	NEG/NEG	POS/POS
Composite Sync	NEG					
Composite Video						
Character Font	7*9	7*9	7*9	7*9	7*9	7*9
Serration	ON	OFF	OFF	OFF	OFF	OFF
EQP	OFF	OFF	OFF	OFF	OFF	OFF

Preset Mode No.	19	20				
Signal Name	800*600 (100)	1024*768 (85)				
Resolution	800*600	1024*768				
Dot Clock (MHz)	67.50	94.5				
fh (kHz)	63.92	68.677				
fv (Hz)	100.03	85				
Total (dot)	1056	1376				
(uS)	15.64	14.561				
Disp (dot)	800	1024				
(uS)	11.852	10.836				
Front (dot)	40	48				
(uS)	0.593	0.508				
Sync Pulse (dot)	80	96				
(uS)	1.185	1.016				
Back (dot)	136	208				
(uS)	2.015	2.201				
Total (H)	639	808				
(mS)	9.997	11.765				
Disp (H)	600	768				
(mS)	9.386	11.183				
Front (H)	3	1				
(mS)	0.047	0.015				
Sync Pulse (H)	4	3				
(mS)	0.063	0.044				
Back (H)	32	36				
(mS)	0.501	0.524				
Interlace	NON	NON				
Polarity (H/V)	POS/POS	POS/POS				
Composite Sync						
Composite Video						
Character Font	7*9	7*9				
Serration	OFF	OFF				
EQP	OFF	OFF				

## Distortion Adjustment

### Factory Mode Setting

\*After completion of adjustment exit the factory mode and data will be saved.

Signal : All signals Cross hatch

Perform the adjust for signal No. 14 in step 6-1~3.

Perform the adjust for above all signal in step 6-4,5.

### 1. Picture Tilt Adjustment

- (1) Receive signal 14 (Cross hatch).
- (2) When OSM MENU is displayed, Select the "  " icon.
- (3) Make sure that the picture tilt meets the following standards.

$$X \leq \pm 1.0 \text{ mm}$$

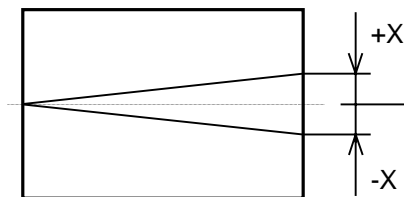

### 2. Pincushion Balance Adjustment

- (1) When OSM MENU is displayed, Select the "  " icon.
- (2) Make sure that the Pincushion Balance meets the following standards.

$$A - B \leq 0.5 \text{ mm}$$

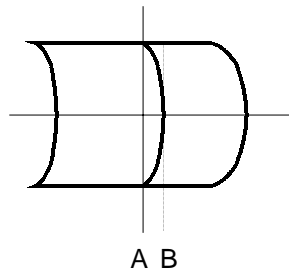

### 3. Parallelogram distortion Adjustment

- (1) When OSM MENU is displayed, Select the "  " icon.
- (2) Adjust "+", "-" SW so that the vertical line and horizontal line at the screen's center fall at right angles. (less than  $90 \pm 0.5$  degree)

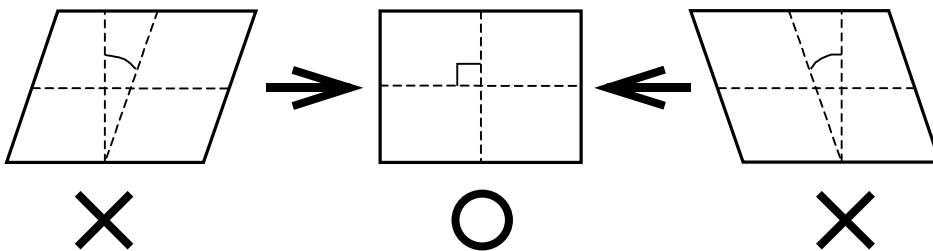

#### 4. Side Pincushion Adjustment

- (1) When OSM MENU is displayed, Select the “” icon.
- (2) Make sure that the side pincushion distortion meets the following standards.

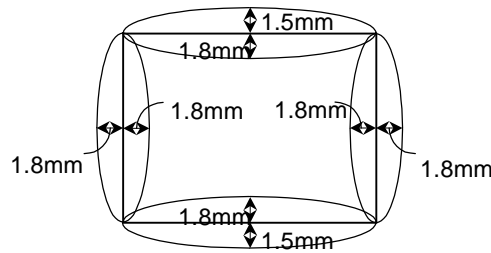

#### 5. Trapezoid Distortion Adjustment

- (1) When OSM MENU is displayed, Select the “” icon.
- (2) Make sure that the trapezoid distortion meets the following standards.

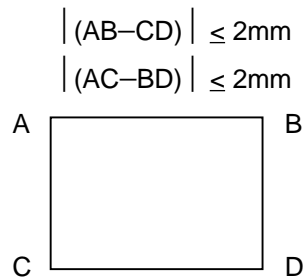





#### 6. Preset Picture Size and Position Adjustment

##### Factory Mode Setting

Signal: All Signals    Cross hatch

\*Perform the Preset Picture Size and Position Adjustment for above all signal.

- (1) When OSM MENU is displayed, Select the “”, “”, “”, “” icon.
- (2) Adjust the picture size and position as listed below by “-”, “+” SW.

##### Picture size

H :  $310 \pm 2\text{mm}$

V :  $232 \pm 2\text{mm}$

##### Picture position

H :  $| (X_{\text{TOP}} - X_{\text{BOTTOM}}) | \leq 3\text{mm}$

V :  $| (X_{\text{LEFT}} - X_{\text{RIGHT}}) | \leq 3\text{mm}$

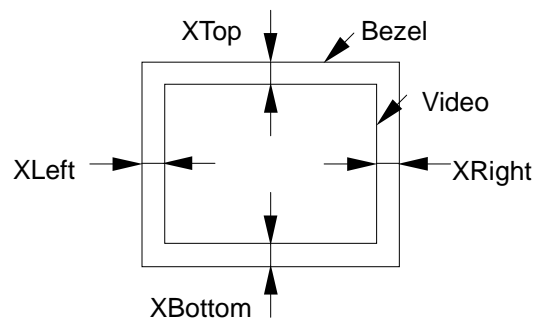

7. Purity

- (1) Receive signal 14(Cross hatch pattern).
- (2) The CRT face should be facing east and degauss the entire unit by external degaussing coil.
- (3) Make sure the single color purity.  
If not, readjust CPC magnet and touch up using correction magnets.

8. Convergence

$C_H$  : Convergence error of horizontal direction

$C_V$  : Convergence error of vertical direction

$C_S$  : Total direction of Convergence error

(Calculate by " $\sqrt{C_H^2 + C_V^2}$ ")

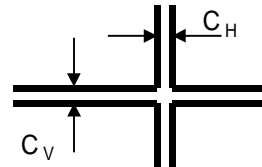

- (1) Receive signal 14(Cross hatch pattern).
- (2) Measure convergence error., If it is out of spec, adjust static convergence by 4-pole magnets and 6-pole magnets.

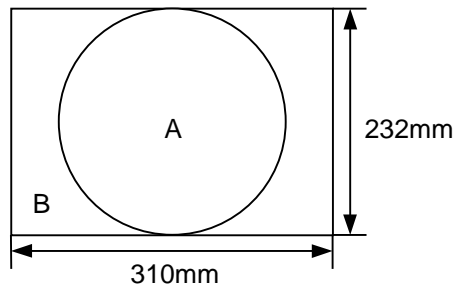

A Zone (A circle 232 mm in the center of the CRT face center)

$C_H, C_V$ : Within 0.35 mm

$C_S$ : No rule

B Zone (Areas outside of zone A within the rectangle of 310 mm×232 mm)

Safety with the list below.

	$C_H \leq 0.35$ mm	$0.35$ mm $< C_H < 0.40$ mm
$C_V \leq 0.35$ mm	OK	Calculate $C_S$ and judge Within 0.50 mm → OK
$0.35$ mm $< C_V < 0.40$ mm	Calculate $C_S$ and judge Within 0.50 mm → OK	Need to touch up

## Write and Inspection for Plug and Play Communication

### 1. Construction of System

This system should be connected as shown below.

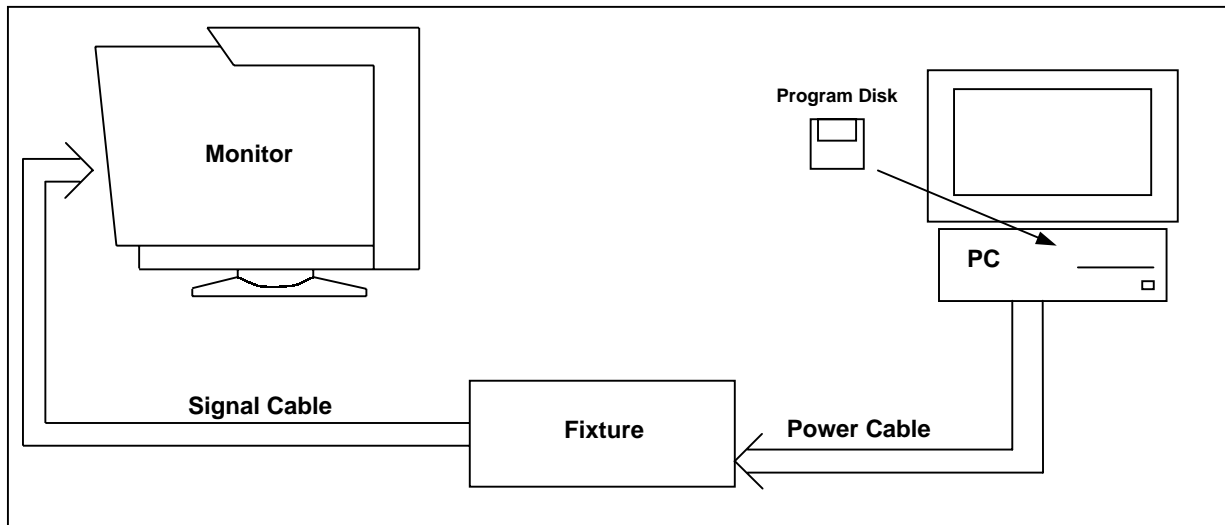

Note: PC clock speed should be below 266MHz. OS is PC-DOS.

Fixture Board can be connected directly to PC without Printer Cable.

### 2. EDID Write and Inspection Method

- 1) Run specified EDID write and Inspection program on PC-DOS mode.  
The monitor turns into the self test mode.
- 2) Run the specified EDID write and inspection program under PC-DOS mode.
- 3) Key in the serial No. or Scan serial No. bar code.
- 4) Press "Return" key to write the EDID data.
- 5) Press "F1" key to inspect DDC1 communication.
- 6) Press "F2" key to inspect DDC2 communication  
EDID DATA Format: Please refer the 3. EDID data File.

3. EDID DATA FILE

MultiSync V720 EDID Serial No. Format

Week of Manufacture (Month\*4)  
Year of Manufacture

	0	1	2	3	4	5	6	7	8	9	A	B	C	D	E	F
00	00	FF	FF	FF	FF	FF	FF	00	38	A3	E5	25	01	01	01	01
10	18	09	01	02	0C	21	18	78	EA	21	18	A1	55	4A	99	26
20	11	48	4C	FF	EE	00	31	59	45	59	61	59	71	4A	81	40
30	01	01	01	01	01	01	30	2A	00	98	51	00	2A	40	30	70
40	13	00	36	E8	10	00	00	1E	00	00	00	FD	00	37	78	1F
50	46	0B	00	0A	20	20	20	20	20	20	00	00	00	FC	00	4E
60	45	43	20	56	37	32	30	0A	20	20	20	20	00	00	00	FF
70	00	39	36	30	30	30	30	31	59	41	0A	20	20	20	00	C4

Serial No Area 9bytes Check Sum

MultiSync V721 EDID Serial No. Format

Week of Manufacture (Month\*4)  
Year of Manufacture

	0	1	2	3	4	5	6	7	8	9	A	B	C	D	E	F
00	00	FF	FF	FF	FF	FF	FF	00	38	A3	BC	61	01	01	01	01
10	2D	0A	01	02	0C	21	18	78	EA	21	18	A1	55	4A	99	26
20	11	48	4C	FF	EE	00	31	59	45	59	61	59	71	4A	81	40
30	01	01	01	01	01	01	EA	24	00	60	41	00	28	30	30	60
40	13	00	36	E8	10	00	00	1E	00	00	00	FD	00	37	78	1F
50	46	0B	00	0A	20	20	20	20	20	20	00	00	00	FC	00	4E
60	45	43	20	56	37	32	31	0A	20	20	20	20	00	00	00	FF
70	00	30	59	30	30	30	30	31	59	41	0A	20	20	20	00	36

Serial No Area 9bytes Check Sum

Diamond Scan 71 EDID Serial No. Format

Week of Manufacture (Month\*4)  
Year of Manufacture

	0	1	2	3	4	5	6	7	8	9	A	B	C	D	E	F
00	00	FF	FF	FF	FF	FF	FF	00	34	AC	40	45	01	01	01	01
10	2D	0A	01	02	0C	21	18	78	EA	21	18	A1	55	4A	99	26
20	11	48	4C	FF	EE	00	31	59	45	59	61	59	71	4A	81	40
30	01	01	01	01	01	01	EA	24	00	60	41	00	28	30	30	60
40	13	00	36	E8	10	00	00	1E	00	00	00	FD	00	37	78	1F
50	46	0B	00	0A	20	20	20	20	20	20	00	00	00	FC	00	44
60	69	61	6D	6F	6E	64	53	63	61	6E	37	31	00	00	00	FF
70	00	30	59	30	30	30	30	31	59	41	0A	20	20	20	00	90

Serial No Area 9bytes Check Sum



Bar Code Format(code39)

Digit		1	2	3	4	5	6	7	8	9	10	11	12	13	14	15	16	17	18		
Format	*	N	N	N	N	N	N	N	N	N	_	Y	M	S	S	S	S	S	F	R	*
Example	*	N	B	7	0	0	9	1	T	_	0	Y	0	0	0	0	1	Y	E	*	

\*+Set Assembly Code + 1 space + Serial No. + \*

Set Assembly code depends on CRT and Destination.

Serial No. Descriptions:

Y: Manufactured Year (Last digit) ex. 0 → 2000

M: Manufactured Month 1 ~ 9, X(October),  
Y(November), Z(December)

S: Serial No. ( 5digits) 00001 ~ onward  
(restart when month is changed)

F: Factory Code: Y is NPG China Factory

R: Product Revision code: start from E

(DiamondScan 71 from A)

EDID Code Input Procedure ex. (V720(B))

- 1) Scan Bar code (18 digits) NB70091T\_ 0Y00001YE
- 2) Skip 9 digits then find the Serial No. 0Y00001YE
- 3) Make Year hex Code from Year digit 0 → 0Ah
- 4) Make Week hex Code from Month digit 11\*4 = 44 → 2Dh
- 5) Change Serial No. to ASCII code 30h 59h 30h 30h 30h 30h 31h 59h 45h
- 6) Apply Serial No. Information to the default EDID code.
- 7) Download EDID from PC to Monitor.
- 8) DDC1 Inspection
- 9) DDC2B Inspection

# TROUBLE SHOOTING

Refer to User's Manual trouble shooting section before using this chart.

## TABLE OF CONTENTS

	<b>Page</b>
1. NO OPERATION, POWER LED FLASH .....	32
2. NO OPERATION, POWER LED OFF .....	33
3. VIDEO NOISE, OUT OF SYNC .....	34
4. NO VIDEO .....	35
5. NO RASTER .....	36
6. TROUBLE IN H.V SYNC .....	37
7. PINCUSHION POOR.....	38

# 1. NO OPERATION, POWER LED FLASH

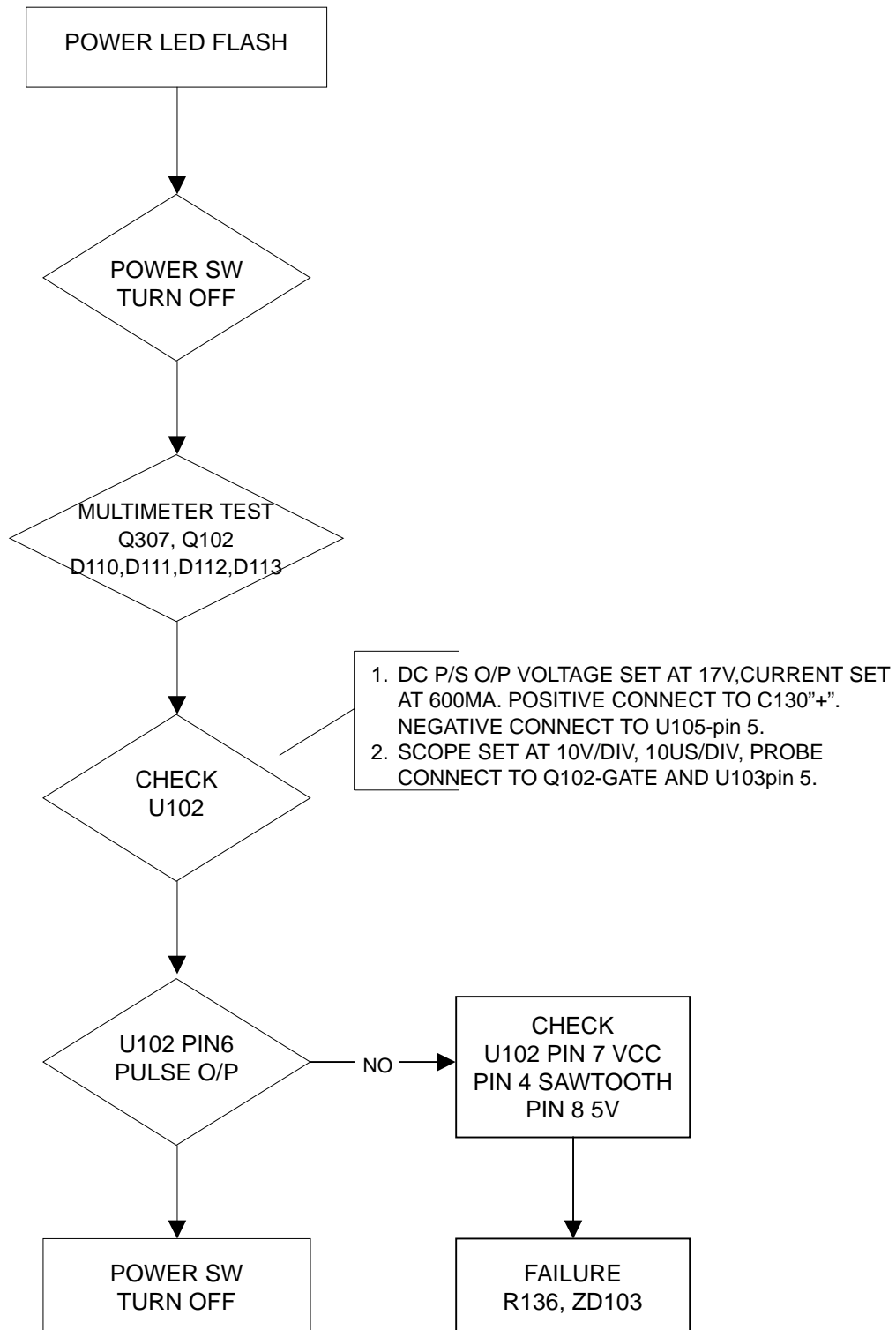

## 2. NO OPERATION, POWER LED OFF

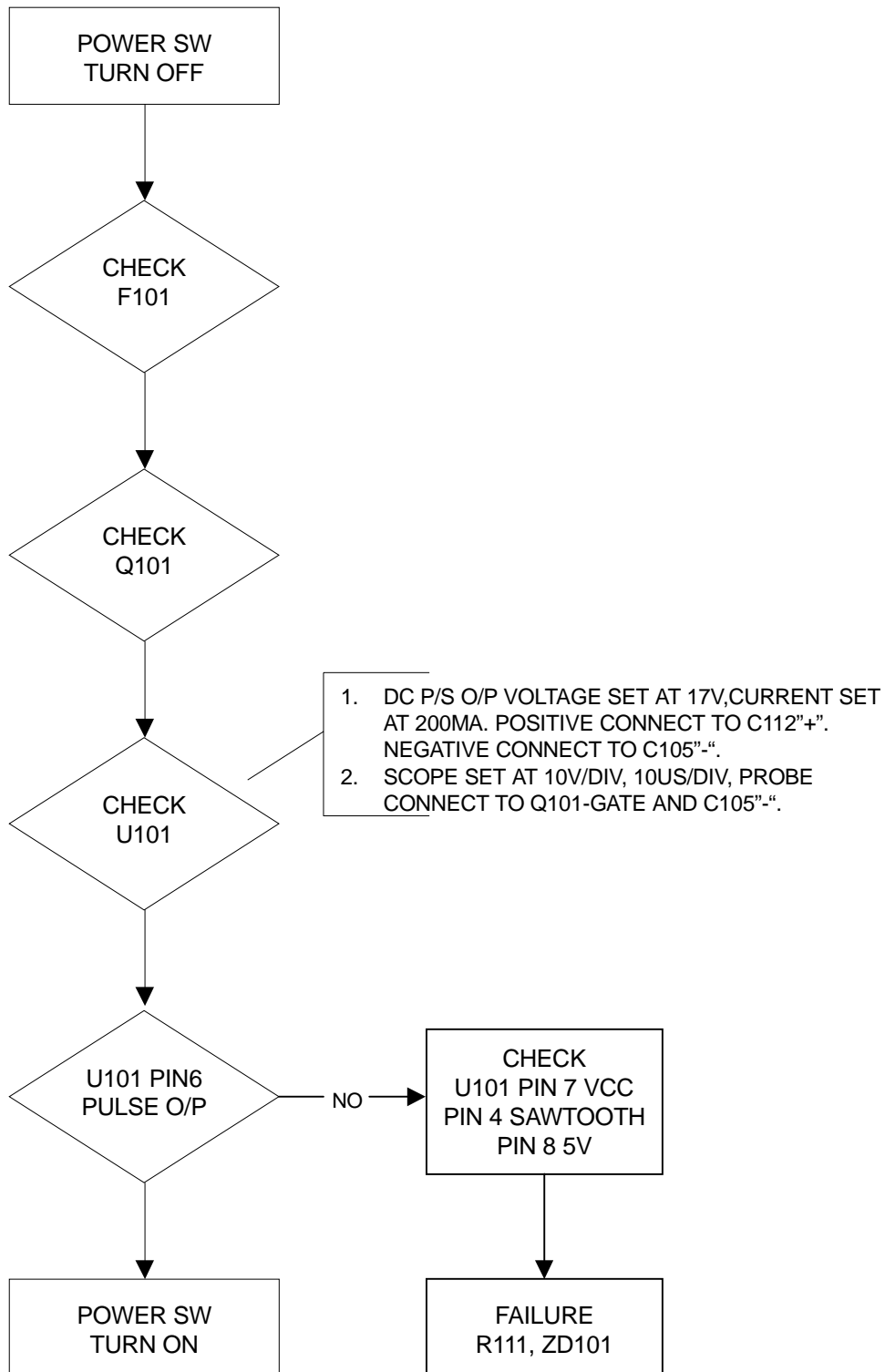

### 3. VIDEO NOISE, UNSYNCHRONOUS

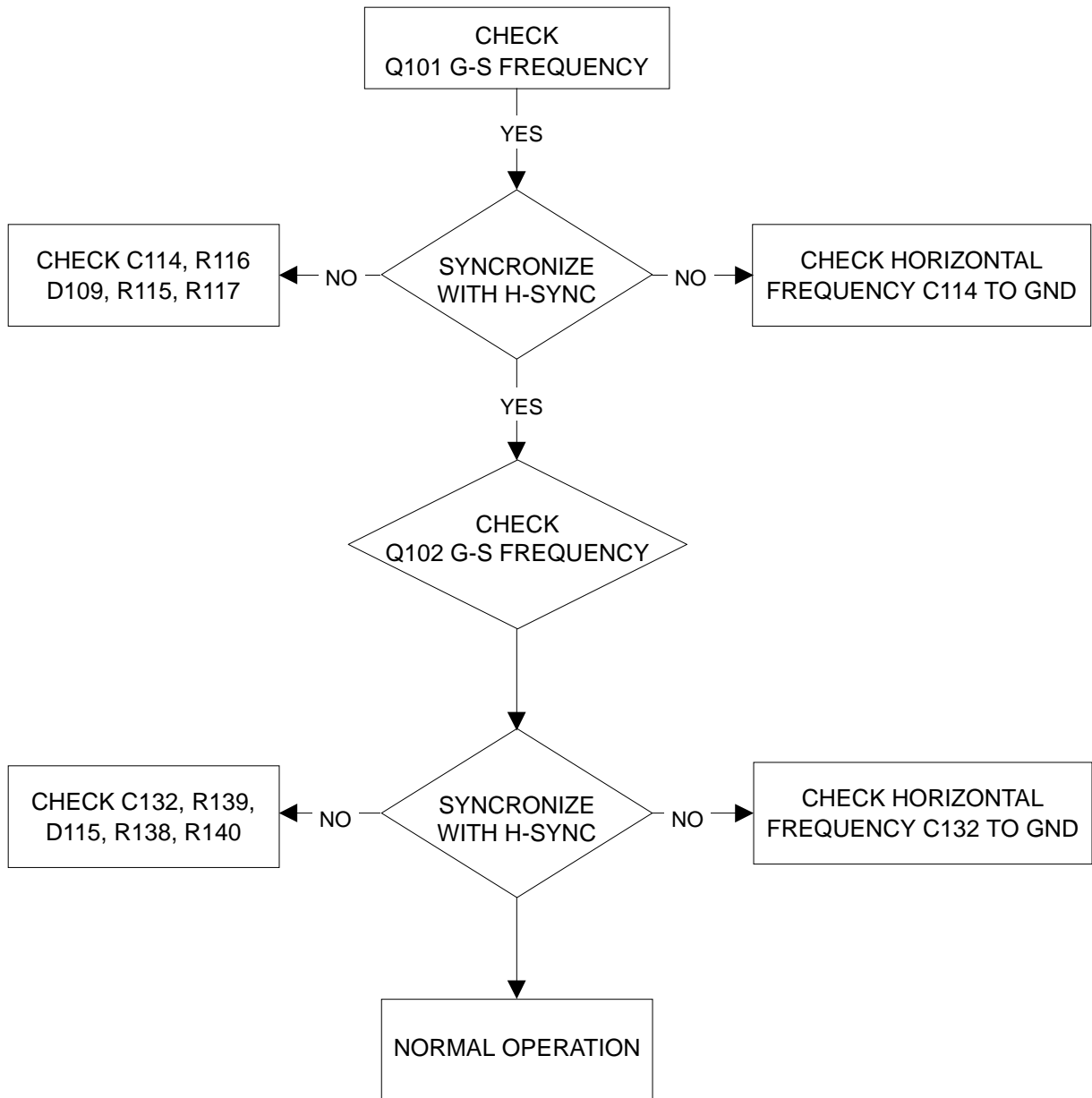

4. NO VIDEO

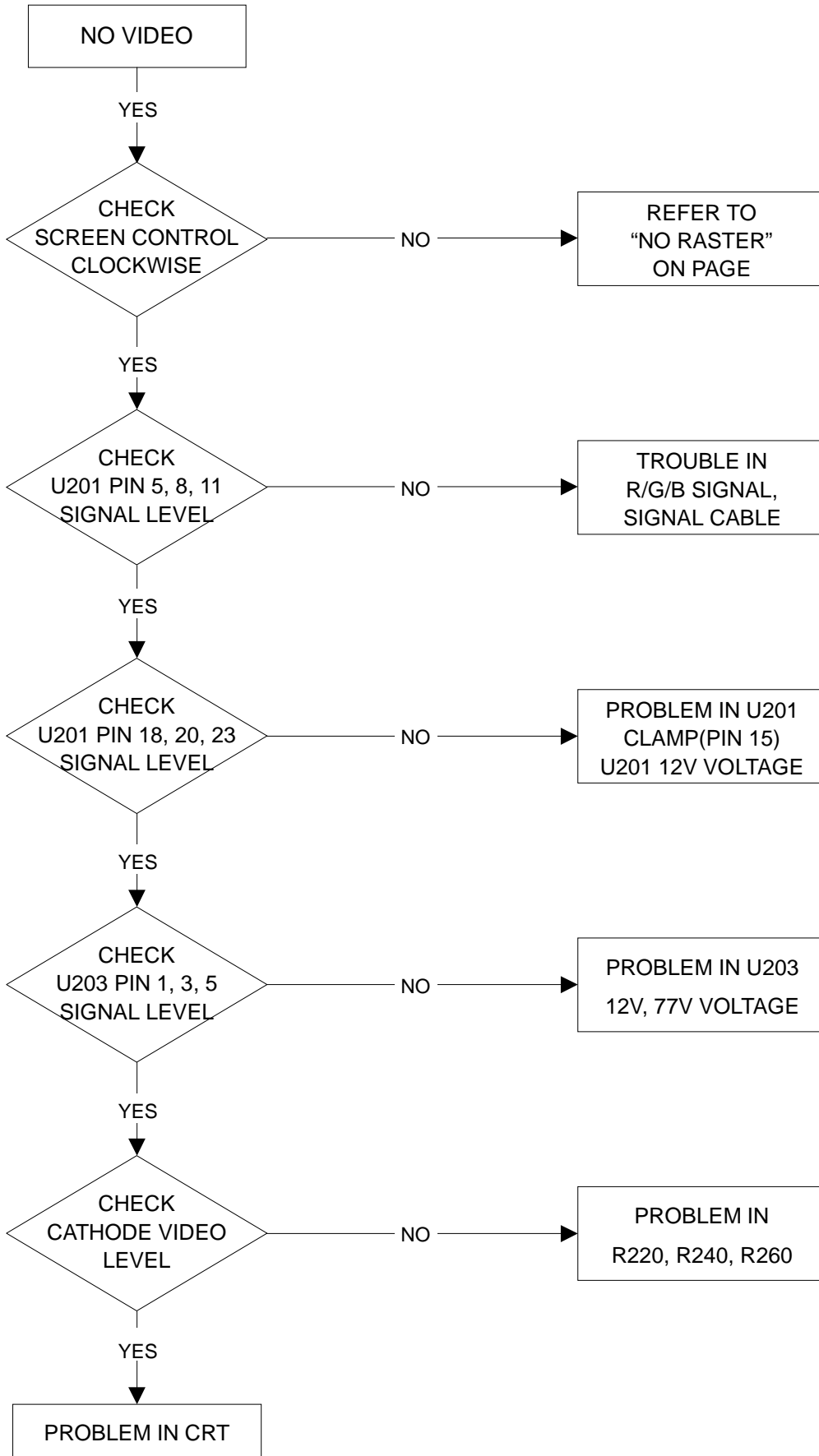

## 5. NO RASTER

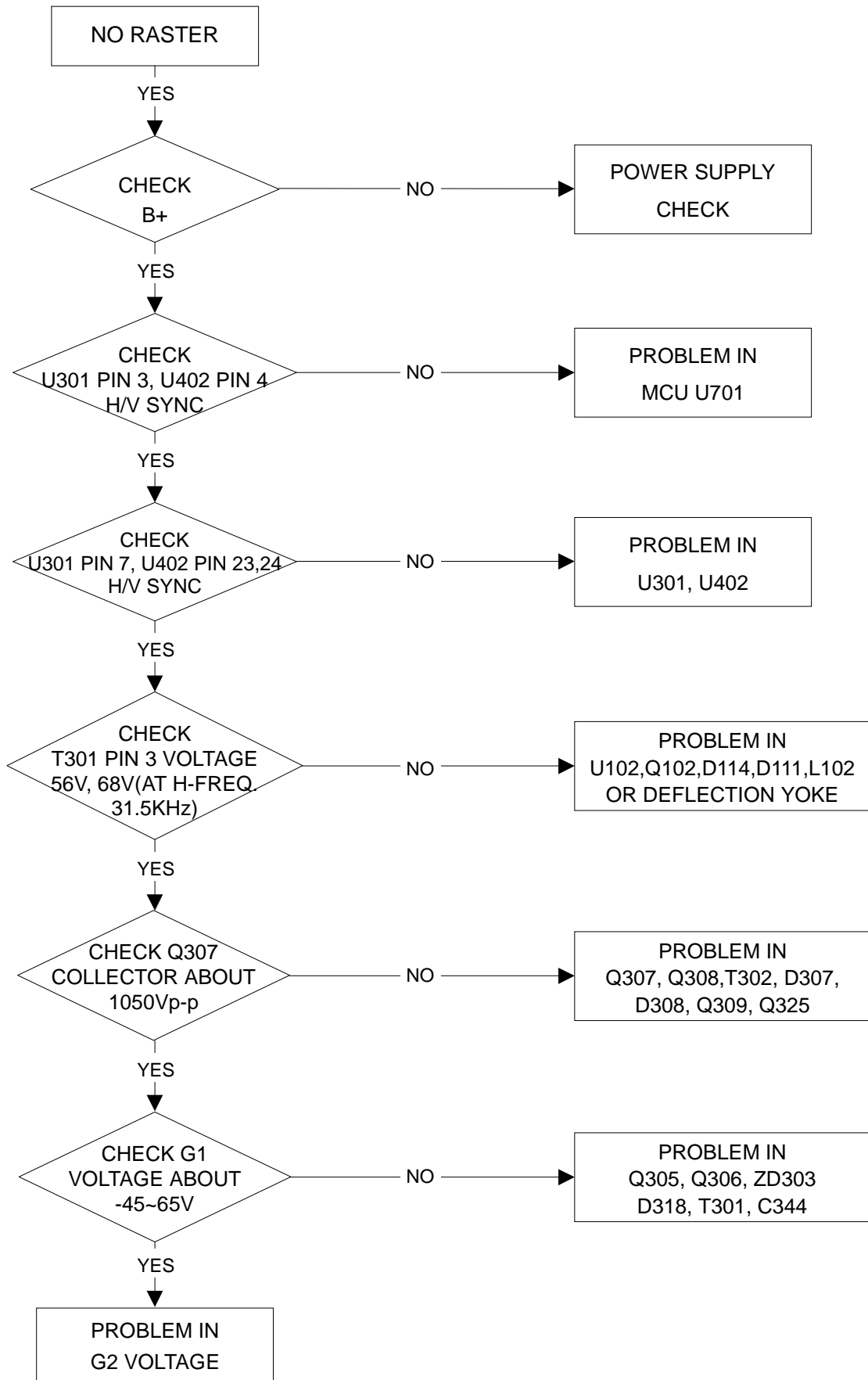

## 6. TROUBLE IN H. V SYNC

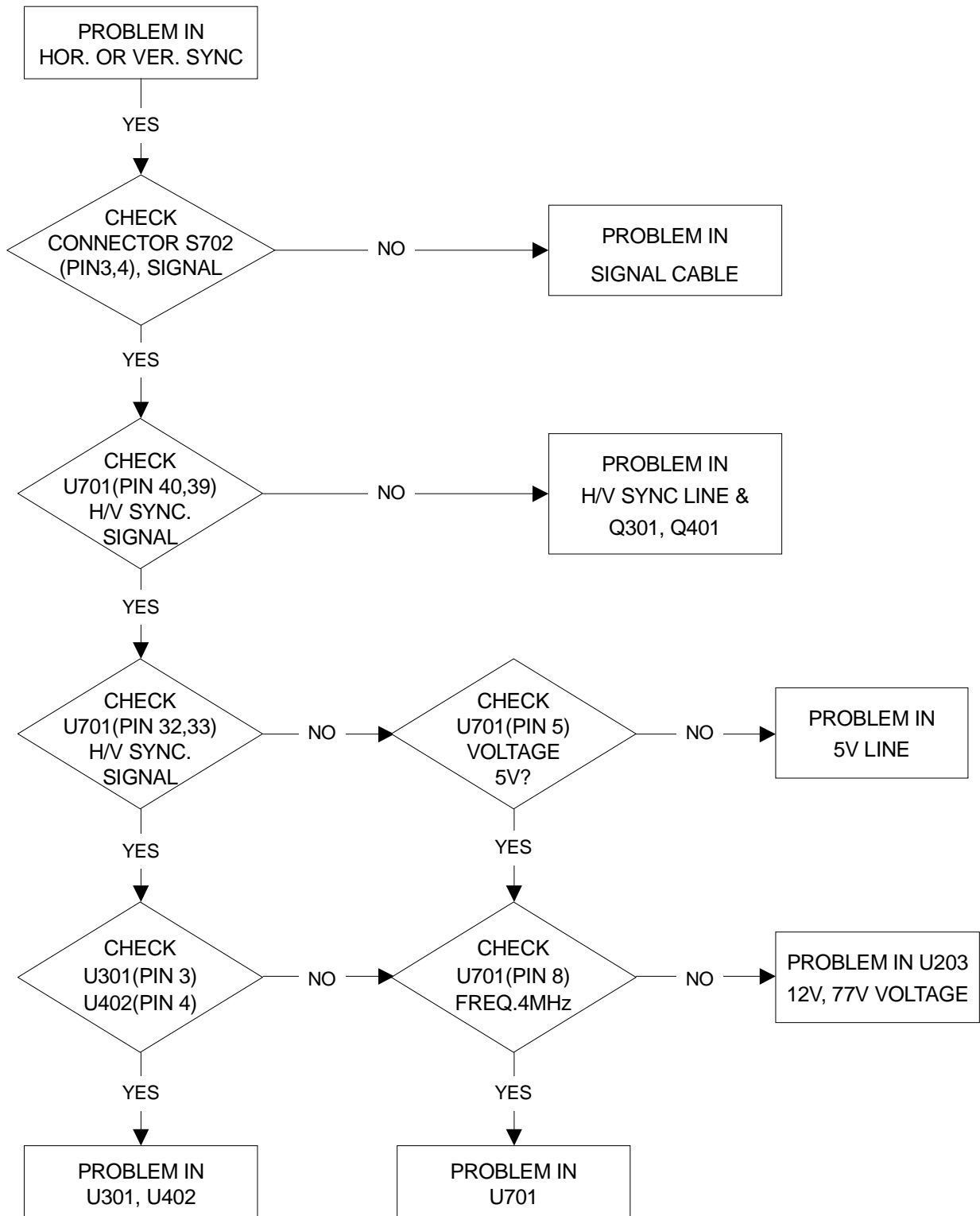



## 7. POOR PINCUSHION

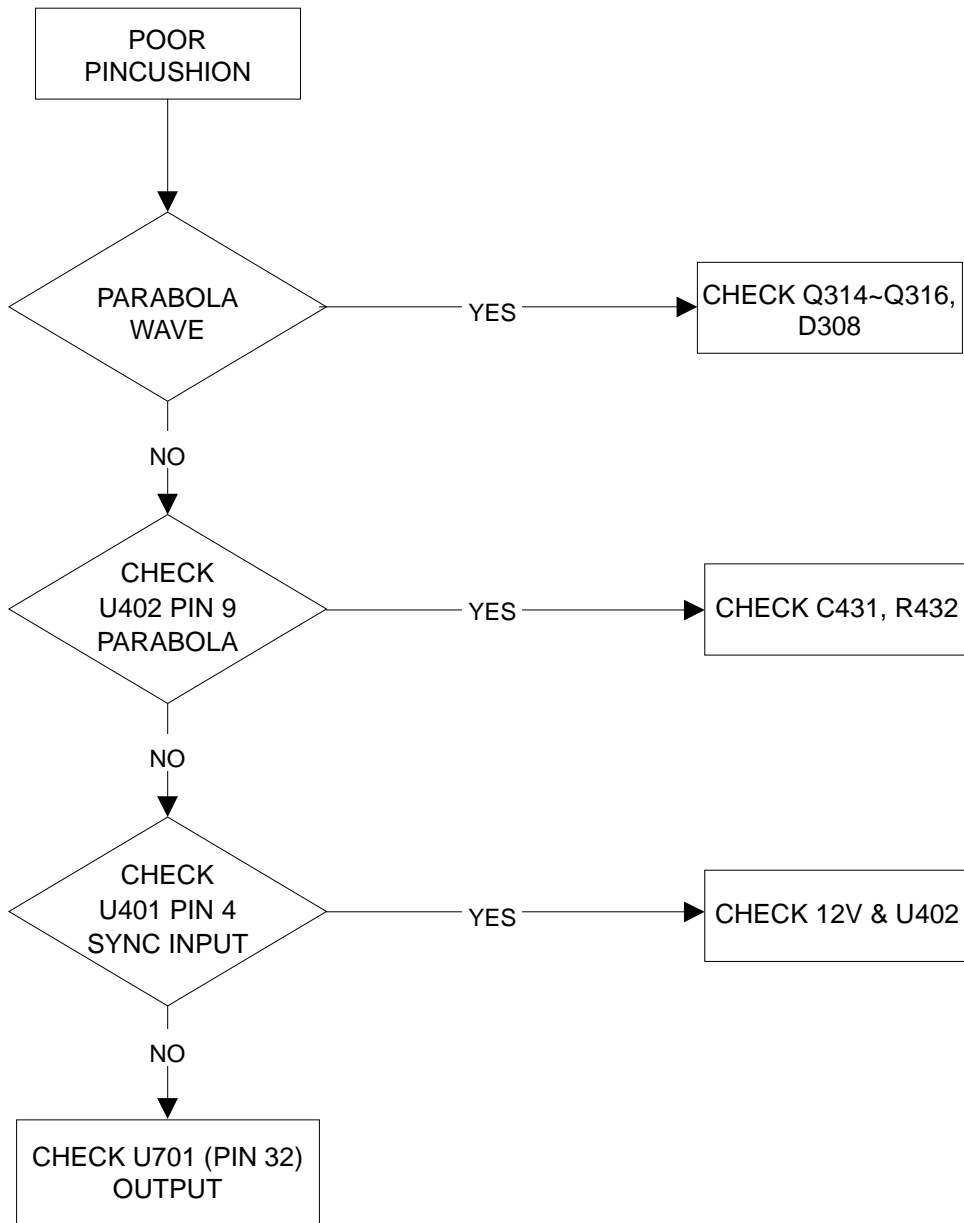

# CIRCUIT DESCRIPTION

## TABLE OF CONTENTS

	<b>Page</b>
1. Power supply circuit .....	40
2. MCU .....	43
3. 2-wire serial CMOS EEPROM .....	56
4. Horizontal deflection signal processing .....	57
5. Vertical compensation and geometrical compensation of the raster .....	59
6. Horizontal drive and power supply output .....	62
7. Horizontal amplitude control .....	63
8. Blanking and spot killer .....	64
9. Video amplifier system with on-screen display .....	65
10. Monolithic triple 13.5nS CRT driver .....	67
11. On screen display .....	71

## 1. Power supply circuit

### ① Outline

This power supply unit adopts the switching mode technology, and is an off-line mode type unit that provided several different DC outputs. The scanning frequency is available in different values ranging from 31 kHz to 69 kHz. Moreover, it is capable to operate at an AC input voltage of 100V ~ 240V and an AC frequency of 50-60 Hz $\pm$ 3Hz.

The block diagram is the functional construction schematics, that shows the major functions of this power supply unit.

### ② Harmonics (OPTION)

L107 is a harmonic choke circuit that reduces the harmonic peak currents, for the purpose of fulfilling the requirement items of IEC 1000-3-2.

### ③ EMI

The EMI circuit has a 2-stage construction, with the first stage consisting of the common mode choke unit and one X-capacitor, and the second stage consisting of the common mode choke unit and four Y-capacitors.

R101 is the bleed resistor of the X-capacitor. When the power supply switch is turned OFF, this resistor carries out the emergency charging of the capacitor C101.

The EMI is the circuit that prevents the monitor switching noise from being generated, there by minimizing the negative influence on the other electronic equipment.

### ④ AC rectifier and smoothing capacitor

The AC input is rectified by means of the full-bridge rectifier, that consists of the diodes D101 to D104. The AC voltage is converted into the DC voltage by passing through the next stage, that consists of the smoothing capacitor C105.

TH101 is a NTC thermistor for the power supply at the in-rush current limit.

### ⑤ Degaussing circuit

The degaussing circuit consists of the PTC thermistor TH102, the degaussing coil and the relay RL101. The relay is controlled by means of the +12V control signal coming from the CPU.

### ⑥ Transformer and energy induction

1) When the PWM controls IC KA3842A chip, a driving pulse is generated at the gate of the transistor Q101, and Q101 turns ON. The current returns from the "plus" (+) side of the energy-supplying capacitor C105 to the "minus" (-) side of the same capacitor C105, passing through the transformer Q101 D-S. During the ON cycle, the energy is stored in the transformer T101. The transistor Q101 turns OFF when the driving pulse disappears from Q101. As a result, all voltages of the dot ends of the winding flow to the positive direction and reach the fly-back rectifier. At that point of time, the diodes of the rectifier of the secondary side turn ON, a temporary energy is induced at the secondary side, and the ON cycle of the driving pulse is repeated.

2) The power supply MOS FET Q101 carries out the ON/OFF operation of the control unit, by means of U101 KA3842A. KA3842A is a PWM (pulse width modulation) IC chip, with 16 V starting voltage and 10 V cut-off voltage.

The following list shows the pin layout of KA3842A pulse width modulation IC chip.

Pin 1:	Feedback	Pin 2:	Compensation
Pin 3:	Current sensor	Pin 4:	Oscillator
Pin 5:	Ground (GND)	Pin 6:	Pulse output
Pin 7:	VCC	Pin 8:	VREF (5.1 V)

3) Overcurrent protection

R111 is a sensor resistor, and it has the function of increasing the current of this loop when the output of the secondary side is either in the overloaded state or is insufficient.

Since the current passing through the R111 sensor resistor has voltage dropping effect, the operation of the output pulse is stopped when a voltage lower than 1 Volt is detected at the pin number 3 of the KA3842A chip, and the switch of the power supply MOS FET is kept in the “break” state until the VCC voltage is charged up to 16 Volts, and the operation of U101 KA3842A is resumed.

When it is not clearly known whether there is voltage shortage or not, however, this circuit repeats the ON/OFF switching, and the power supply LED lights up.

4) Starting circuit

The resistor R123 and R148 and the transistor Q112 and diode D119 and resistor R131, R149 and zener diode ZD105 are for the starting operation. When the circuit starts its operation, the power supply transformer T101 supplies the auxiliary 12 Volt power to the control IC chip U101 via pins 6 and 7 of the winding transformer T101.

5) Synchronization circuit

The synchronization signal is induced from the fly-back transformer (FBT), and carries out the synchronization with the power supply frequency. The frequency range is from 31 kHz to 70 kHz, and the component elements of the synchronization circuit are C114, R116, D109, R115 and R117.

6) Feedback circuit

The feedback circuit loop induces the 12 V voltage through the pin 6 and the pin 7 of the power supply transformer. That voltage is connected with the pin 3 of the IC chip U101 by passing through D108, C113 and passing next through R122, VR101 and R120. This is a regular loop.

7) Snubber circuit

The snubber circuit has the function of clamping the ON/OFF spikes of the power supply MOS-FET, and its component elements D105, C106, R106 make up a snubber that turns OFF the power supply MOS-FET.

8) Secondary rectifier and smoothing rectifier

The secondary rectifier is a harmonic rectifier consisting of D111, C124 and R128, and it works as a snubber circuit as well. The capacitors C120 and C138 are the smoothing rectifier working on the 45 Volt DC output. There are also other DC outputs, such as 80 Volt (D110), 13.5 Volt (D112) and 6.3 Volt (D113).

⑦ Power saving

Suspend mode : Every DC voltage operation of the CRT is turned OFF.

The color of the power LED101 switches from green to orange.

OFF mode : This is the mode in which the CPU control unit turns OFF the power supply, but the power turns ON when the user touches the keyboard.

The power LED switches to dark orange color.

- 1) When the power switch is turned ON when there is nothing being entered in the video cable. At that time, if the video is shifted from the free-run mode to the suspend mode, the transistor Q107 turns OFF and the operation returns to the OFF mode within a few seconds.
- 2) As for the sequence of steps that turn the operation to the OFF mode, if the keyboard is not touched for a given period of time that a preset in advance, the CPU outputs the LOW level signal to the transistor Q107, then Q105 turns OFF, the transistor Q108 and Q104 turns OFF. As a result the power is shut out at that state.
- 3) When the user touches the keyboard in the OFF mode, the operation is resumed, the video signals V-SYNC and H-SYNC turn ON the CPU via resistor R129 and R159, then the transistor Q105 and Q107 turn ON, the transistors Q104 and Q108 turn ON. As a result the operation returns to the ON state.

⑧ DC/DC

The DC/DC voltage is DC 45 volts, and since the set-up voltage is variable from 62 volts to 160 volts, it is variable depending on the horizontal synchronism. The frequency band is variable from 31 kHz to 69 kHz. The voltage is fed back from the fly-back transformer (FBT). The DC/DC output voltage is used as high-voltage input of FBT T301.

- 1) DC/DC is a step-up circuit, and consists mainly of the choke L106, the transistor Q102, the diode D114 and U102.
- 2) When the PWM controls U102 IC KA3843, a driving pulse is generated at the gate of the transistor Q102, and the transistor Q102 turns ON. During the ON cycle, the energy is stored in the choke L106. The transistor Q102 turns OFF when the driving pulse disappears from the gate of the transistor Q102. As a result, the voltage at the dot terminal of the winding flows in the positive direction and goes to the fly-back rectifier. The energy stored in the choke L106 is entered in the FBT, passing through the choke L106, the diode D114 and the capacitor C129.
- 3) The feedback is detected by the FBT via diode D130, the capacitor C145, the resistor R145 the variable resistor VR102 and the fixed resistor R146, and is connected to the U102-2 pin. This is loop is the regular type one.
- 4) The frequency of the synchronization signal coming from video H-SYNC is variable from 31 kHz to 69 kHz. The circuit consists of the capacitor C132, the resistor R139, the diode D115, the resistor R138 and the resistor R140.
- 5) The soft start circuit consists of the resistor R178, the capacitor C164, the diode D133 and the diode D117.

## 2. MCU

### Monitor MCU Specification

#### Frequency Specification

H-freq. : 29.5K – 70KHz

V-freq. : 43 – 160Hz

Judge polarity only when frequency is 31.5 KHz and 37.8 KHz

Support composite sync detection

#### System Architecture

1. MCU – Weltrend WT6016, 16K bytes ROM size
2. EEPROM – 24C04 series, 4K bit, with ID code for identify initialization.
3. OSD – Myson MTV016N-12

#### Input

1. Sync input – 2 pins for H-sync & V-sync frequency inverted input.
2. Key input – 2 pins for A/D key input (SELECT, UP, DOWN and RECALL).
3. Burn-in ID input – 1 pins for Burn-in ID input.
4. Reset input – low pulse for reset MCU
5. Crystal input – 2 pins using 8MHz crystal.

#### Output – MCU digital pin

1. Degauss – Active high pulse for 2.5 sec when in degauss. MCU will activate degauss while power on.
2. CS output – 3 pins (CS2, CS1, CS0) for CS control

<b>H-sync</b>	<b>CS2</b>	<b>CS1</b>	<b>CS0</b>
H-sync < 33.25KHz	0	0	0
33.25KHz < H-sync < 36.50KHz	0	1	0
36.50KHz < H-sync < 40.50KHz	0	1	1
40.50KHz < H-sync < 45.10KHz	1	0	0
45.10KHz < H-sync < 51.60KHz	1	0	1
51.60KHz < H-sync < 55.10KHz	1	1	0
55.10KHz < H-sync < 62.15KHz	1	1	0
62.15KHz < H-sync	1	1	1
Mode change	0	0	0

3. Power saving – 2 pins (PMUS, PMUO) for power saving control
- if Hf > 70KHz or Hf < 23KHz, enter power saving mode (suspend).
  - enter power saving mode after 3 sec when condition met.
  - enter suspend mode first for 3 sec before enter off mode if off mode condition met.

Mode	H-sync freq.	V-sync freq.	Burn-in ID	PMUS	PMUO
Normal	Yes	Yes	---	1	1
Stand By	No	Yes	---	0	1
Suspend	Yes	No	---	0	1
Off	No	No	Low	0	0
Burn-in	No	No	High	1	1

4. Mute – 2 pins for screen mute

Mute1 – active low pulse for about 0.6 sec when mode change.

Mute2 – active low pulse for about 1.0 sec when mode change, active with mute 1 simultaneously.

5. D/A – 14 pins (PWM output) are Brightness, Contrast, H-phase, H-size, V-center, V-size, Pincushion, Trapezoid, Rotation, Parallel, Pin-balance, R-gain, G-gain and B-gain.

– DAC value 255 means the maximum output volts except Parallel PWM.

– All D/A except Rotation, Brightness, Contrast, R-gain G-gain B-gain are mode dependent functions.

– Parallel is voltage inverter function.

6. Sync output – 2 pins for H-sync and V-sync negative output, normal high.

7. DDC – 2 pins (DDC SDA/DDC SCL) for DDC1/DDC2B or auto alignment control.

– In auto alignment mode, all keys and OSD are disabled.

8. SDA/SCL – 2 pins for EEPROM and OSD control.

9. WP – 1 pin, high for EEPROM write protect.

Control Panel Operation

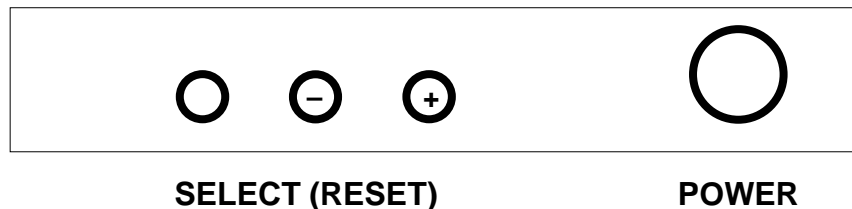

1. Key arrangement – 3 keys for OSD control.

2. Hot key operation

A. Factory Mode: SELECT Key + UP (+) Key if pressed when the power SW on.

B. OSD Position Control Mode: DOWN (-) Key if pressed when the power SW on.

C. Aging mode: Select key if pressed when the power SW on.

## IIC interface

1. DDC1/DDC2B – VESA DDC1/DDC2B is supported.
2. Auto alignment – I<sup>2</sup>C auto alignment protocol is supported.

## Timing Table

Total 24 modes.

1. Factory mode – 20 modes<sup>\*\*</sup> indicate do not care.

Mode	Resolution	H-sync.	V-sync.	H polarity	V polarity
1	VGA 350	31.5KHz	70Hz	+	-
2	VGA 400	31.5KHz	70Hz	-	+
3	VGA 480	31.5KHz	60Hz	-	-
4	MACII 35k	35.0KHz	66Hz	*	*
5	800*600(56)	35.2KHz	56Hz	*	*
6	8514A	35.5KHz	87Hz	*	*
7	640*480(75)	37.5KHz	75Hz	*	*
8	EVGA 400	37.8KHz	84Hz	-	+
9	800*600(60)	37.8KHz	60Hz	*	*
10	640*480(85)	43.3KHz	85Hz	*	*
11	800*600(75)	46.8KHz	75Hz	*	*
12	1024*768(60)	48.3KHz	60Hz	*	*
13	MACII 49k	49.7KHz	74Hz	*	*
14	800*600(85)	53.6KHz	85Hz	*	*
15	1024*768(70)	56.4KHz	70Hz	*	*
16	1024*768(75)	60.0KHz	75Hz	*	*
17	640*480(120)	63.7KHz	120Hz	*	*
18	1280*1024(60)	64.0KHz	60Hz	*	*
19	800*600(100)	64.0KHz	100Hz	*	*
20	1024*768(85)	68.6KHz	85Hz	*	*

<sup>\*\*</sup> indicate do not care.

2. User mode – 4 modes  
– FIFO replacement is applied.



## Pin Definition

<b>Pin</b>	<b>Name</b>	<b>Description</b>	<b>I/O</b>
1	DA2	Pin-balance PWM	O
2	DA1	H Position PWM	O
3	DA0	H size PWM	O
4	Reset	Low reset	I
5	Vdd	+5V	I
6	Vss	Ground	I
7	Osc O	8MHz Crystal out	O
8	Osc I	Crystal in	I
9	PB5	EEPROM/OSD SDA	I/O
10	PB4	EEPROM/OSD SCL	O
11	PB3	Test Pattern	O
12	PB2	CS1	O
13	PB1	CS0	O
14	PB0	PMU OFF	O
15	IRQ	CS2	O
16	PC7	MUTE2	O
17	PC6	Degauss out	O
18	PC5	MUTE1	O
19	PC4	PMU suspend	O
20	PC3	Burn-in ID	I

## GENERAL DESCRIPTION

The WT6016 is a member of WT60XX microcontroller family. It is specially designed for digital controlled multi-sync monitor. It contains 8-bit CPU, 16K bytes ROM, 288 bytes RAM, 14 PWMs, parallel I/O, SYNC processor, timer, one DDC interface (slave mode I<sup>2</sup>C interface with DDC1), one master/slave I<sup>2</sup>C interface, two 4-bit A/D converters and watch-dog timer.

## FEATURES

- \* 8-bit 6502 compatible CPU, 4MHz operating frequency
- \* 16384 bytes ROM, 288 bytes SRAM
- \* 8MHz crystal oscillator
- \* 14 channels 8-bit/62.5kHz PWM outputs (8 open drain outputs & 6 CMOS outputs)
- \* Sync signal processor with H+V separation, frequency calculation, H/V polarity detection/control
- \* Three free-running sync signal outputs for burn-in test (64kHz/62.5Hz, 48kHz/75Hz, 31kHz/60Hz)
- \* Self-test pattern generator generates cross hatch picture
- \* DDC interface supports VESA DDC1/DDC2B standard
- \* Master/slave I<sup>2</sup>C interface
- \* Watch-dog timer (0.524 second)
- \* Maximum 25 programmable I/O pins
- \* One 8-bit programmable timer
- \* Two 4-bit A/D converter
- \* One external interrupt request
- \* Built-in low V<sub>DD</sub> voltage reset
- \* +5V power supply

## PIN ASSIGNMENT

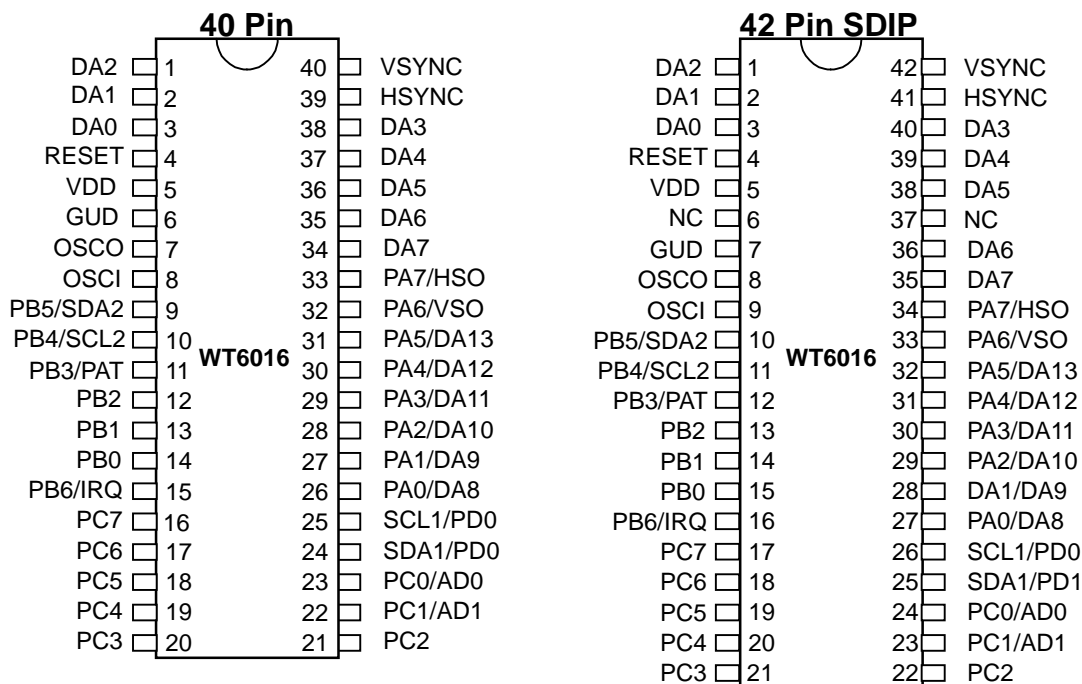

\* I<sup>2</sup>C is a trademark of Philips Corporation.

\* DDC is a trademark of video Electronics Standard Association (VESA).

## PIN DESCRIPTION

Pin No.		Pin Name	I/O	Descriptions
40	42			
1	1	DA2	O	<b>D/A converter 2.</b> Open-drain output. External applied voltage can up to 10V.
2	2	DA1	O	<b>D/A converter 1.</b> Open-drain output. External applied voltage can up to 10V.
3	3	DA0	O	<b>D/A converter 0.</b> Open-drain output. External applied voltage can up to 10V.
4	4	/RESET	I	<b>Reset.</b> Active low. Schmitt trigger input. Internal pull high.
5	5	VDD		<b>Power supply (+5V).</b>
6	7	GND		<b>Ground (0V).</b>
7	8	OSCO	O	<b>Oscillator Output.</b> Connects a 8MHz crystal.
8	9	OSCI	I	<b>Oscillator Input.</b> Connects a 8MHz crystal.
9	10	PB5/SDA2	I/O	<b>I/O Port B5 or I<sup>2</sup>C data pin.</b> This pin can be an I/O port or I <sup>2</sup> C serial data pin.
10	11	PB4/SCL2	I/O	<b>I/O Port B4 or I<sup>2</sup>C data pin.</b> This pin can be I/O port or I <sup>2</sup> C clock pin.
11	12	PB3/PAT	I/O	<b>I/O Port B3 or self-test pattern output.</b> When as an I/O port, it is same as PB5. When it is configured to test pattern output, a video signal is output.
12	13	PB2	I/O	<b>I/O Port B2. Same as PB0.</b>
13	14	PB1	I/O	<b>I/O Port B1. Same as PB0.</b>
14	15	PB0	I/O	<b>I/O Port B0.</b> When it is an input pin, it has an internal pull-up resistor. When it is an output pin, the source/sink current is 5mA.
15	16	PB6/IRQ	I/O	<b>I/O Port B6 or Interrupt Request.</b> When as interrupt request input, it has an internal pull high resistor. When as an I/O port, it is same as PB3.
16	17	PC7	I/O	<b>I/O Port C7.</b> When it is an input pin, it has an internal pull-up resistor. When it is an output pin, the sink current is 10mA and the source current is 5mA.
17	18	PC6	I/O	<b>I/O Port C6.</b> Same as PC7.
18	19	PC5	I/O	<b>I/O Port C5.</b> Same as PC7.
19	20	PC4	I/O	<b>I/O Port C4.</b> Same as PC7.
20	21	PC3	I/O	<b>I/O Port C3.</b> Same as PC7.
21	22	PC2	I/O	<b>I/O Port C2.</b> Same as PC7.
22	23	PC1/AD1	I/O	<b>I/O Port C1 or A/D converter input 0.</b>
23	24	PC0/AD0	I/O	<b>I/O Port C0 or A/D converter input 1.</b>
24	25	SDA1/PD1	I/O	<b>DDC serial clock or I/O Port D1.</b> When it is a DDC interface pin, It is an open-drain output. When as an I/O port, it is same as Port B.
25	26	SCL1/PD0	I/O	<b>DDC serial clock or I/O Port D0.</b> When it is a DDC interface pin, It is an open-drain output. When as an I/O port, it is same as Port B.
26	27	PA0/DA8	I/O	<b>I/O Port A0 or D/A converter 8.</b> This pin can be the output of D/A converter 8 (source /sink = 5mA) or an I/O pin (source = -100uA, sink = 5mA).
27	28	PA1/DA9	I/O	<b>I/O Port A1 or D/A converter 9.</b> Same as PA0/DA8.
28	29	PA2/DA10	I/O	<b>I/O Port A2 or D/A converter 10.</b> Same as PA0/DA8.
29	30	PA3/DA11	I/O	<b>I/O Port A3 or D/A converter 11.</b> Same as PA0/DA8.
30	31	PA4/DA12	I/O	<b>I/O Port A4 or D/A converter 12.</b> Same as PA0/DA8.
31	32	PA5/DA13	I/O	<b>I/O Port A5 or D/A converter 13.</b> Same as PA0/DA8.
32	33	PA6/VSO	I/O	<b>I/O Port A6 / VSYNC OUT.</b> This pin can be the output of VSYNC or an I/O pin. When as an I/O pin, it is same as PA0.
33	34	PA7/HSO	I/O	<b>I/O Port A7 / HSYNC OUT.</b> This pin can be the output of HSYNC or an I/O pin. When as an I/O pin, it is same as PA0.
34	35	DA7	O	<b>D/A converter 7.</b> Open-drain output. External applied voltage can up to 10V.
35	36	DA6	O	<b>D/A converter 6.</b> Open-drain output. External applied voltage can up to 10V.
36	38	DA5	O	<b>D/A converter 5.</b> Open-drain output. External applied voltage can up to 10V.
37	39	DA4	O	<b>D/A converter 4.</b> Open-drain output. External applied voltage can up to 10V.
38	40	DA3	O	<b>D/A converter 3.</b> Open-drain output. External applied voltage can up to 10V.
39	41	HSYNC	I	<b>HSYNC input.</b> Schmitt trigger input.
40	42	VSYNC	I	<b>VSYNC input.</b> Schmitt trigger input.

## SYNC Processor

The SYNC processor can : (1) separate the composite sync signal; (2) calculate HSYNC and VSYNC frequencies; (3) detect polarities of HSYNC and VSYNC input; (4) control the output polarities of HSO and VSO pin; (5) generate free-running horizontal and vertical sync signals for burn-in test; (6) generate self-test pattern signal.

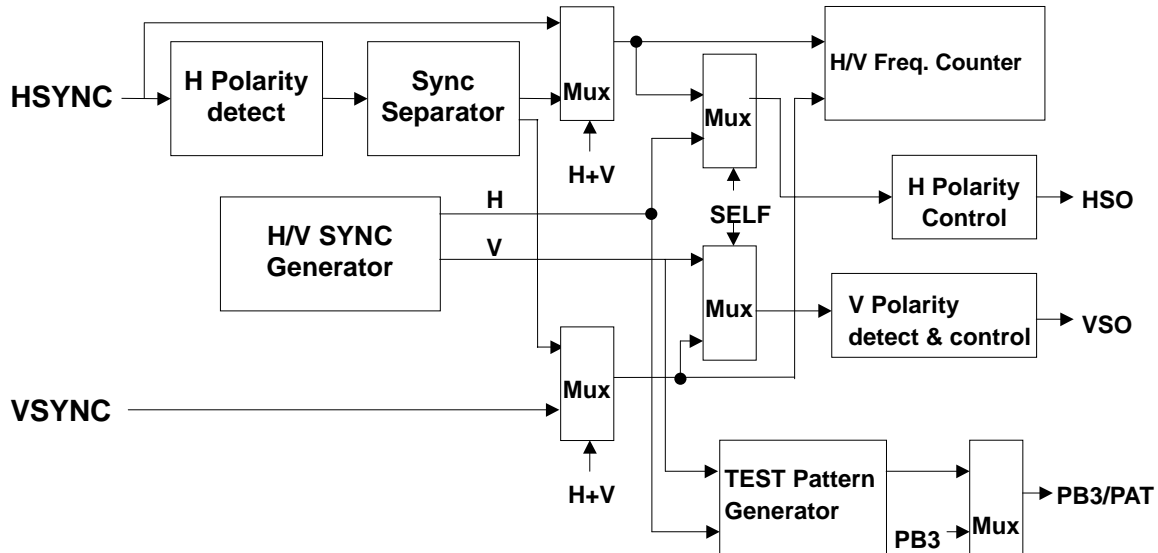

## Composite Sync Signal Separation

The composite sync signal comes from HSYNC pin and is separated by the sync separator.

The operations of sync separator are:

- detect the polarity and convert composite sync signal to positive polarity.
- extract Vsync
  - Pulse width less than 8us will be filtered, but the Vsync will be widened about 8us.
- count the pulses during the separated Vsync is low and save the counter value ( $N_H$ ).
- bypass the composite sync pulses before the counter equals to  $N_H$ .
- start inserting Hsync pulses after the counter equals to  $N_H$  until the separated Vsync is low.
- the period of inserted Hsync is decided by the last two bypassed Hsync.
- the pulse width of the inserted Hsync is 2us.

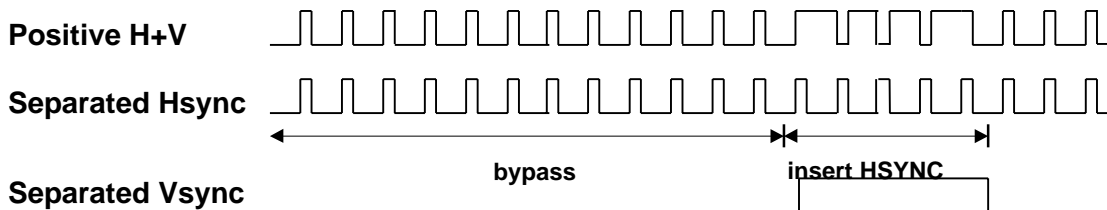

To decide whether the HSYNC input is a composite sync signal or not, program should check the frequency of VSYNC first (reset H+V bit to "0"). If the VSYNC frequency is lower than 15.25Hz (OVF2=1), set H+V bit to "1" and check VSYNC frequency again. If VSYNC still has no frequency, that is power saving condition, program should reset H+V bit. If it has a valid frequency, the HSYNC input is composite signal.

## Frequency Calculation

Horizontal frequency and vertical frequencies calculation are done by using one 10-bit up counter. After power is on, the SYNC processor calculates the vertical frequency first (H/V bit = "0"). A 31.25kHz clock counts the time interval between two VSYNC pulses, then sets the FRDY bit and generates an INT1 interrupt (if IEN\_S bit is "1"). The software can either use interrupt or polling the FRDY bit to read the correct vertical frequency. After reading the REG#16H, the FRDY bit is cleared to "0", counter is reset and H/V bit is set. The SYNC processor starts to count horizontal frequency. The horizontal frequency calculation is done by counting the HSYNC pulses in 8.192 ms. Like the vertical frequency, the horizontal frequency can be read when the FRDY bit is set or INT1 occurs. After reading the REG#16H, the FRDY, INT\_S and H/V bits are cleared. The SYNC processor starts to calculate the vertical frequency again, and so on.

The relationships between counter value and frequency are:

$$\text{Hfreq} = (\text{counter value} \times 122.07) \text{ Hz}$$

$$\text{Vfreq} = (31250 / \text{counter value}) \text{ Hz}$$

The frequency range:

Hfreq range: 122.07 Hz to 124.8 kHz; Resolution: 122.07Hz

Vfreq range: 30.5 Hz to 31.25 kHz

If counter overflowed, the OVF1 bit will be set to "1". The counter keeps on counting until it overflowed again. The OVF2 bit and FRDY bit will be set when counter overflowed twice. This is designed for finding the vertical frequency bellows 15.25Hz. The program should check REG#17H before reading REG#16H.

## Polarity Detect/Control

The polarities of HSYNC and VSYNC are automatically detected and are shown in the H\_POL and V\_POL bits. The polarities of HSO and VSO are controlled by the HOP and VOP bits. For example, set HOP bit to "1", the HSO pin always outputs positive horizontal sync signal, whatever the HSYNC input's polarity is.

## Free-running Sync Signal

The self-generated sync signals are output from HSO and VSO pins if SELF bit is "1". Three kinds of frequencies are provided:

(1)  $\text{Hfreq} = 8\text{MHz}/125 = 64.0\text{kHz}$ ,  $\text{Vfreq} = \text{Hfreq}/1024 = 62.5\text{Hz}$ .

(2)  $\text{Hfreq} = 8\text{MHz}/167 = 47.9\text{kHz}$ ,  $\text{Vfreq} = \text{Hfreq}/640 = 74.9\text{Hz}$ .

(3)  $\text{Hfreq} = 8\text{MHz}/257 = 31.1\text{kHz}$ ,  $\text{Vfreq} = \text{Hfreq}/512 = 60.8\text{Hz}$ .

The output polarities are controlled by the HOP and VOP bits.

The pulse width of HSO is 2us and VSO is four HSO cycles. The timing relationship is shown in the following:

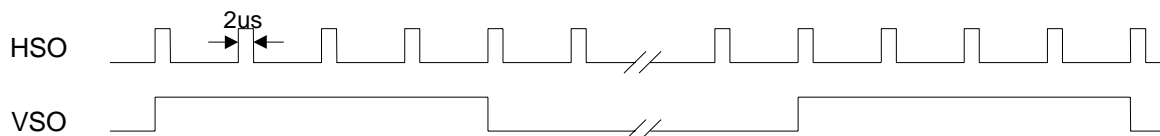

## Test Pattern Generation

A self-test pattern signal comes out from pin PB3/PAT. It can generate a cross hatch picture, a inverted cross hatch picture, a whit epicture or a black picture.

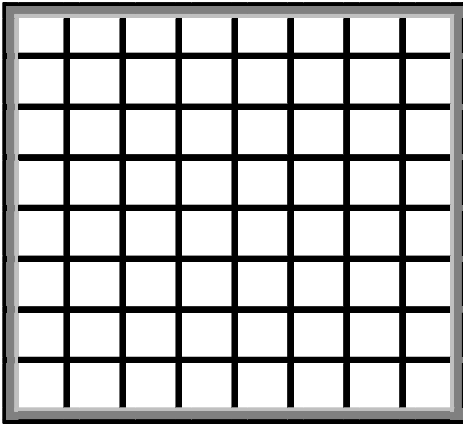

8 × 8 cross hatch

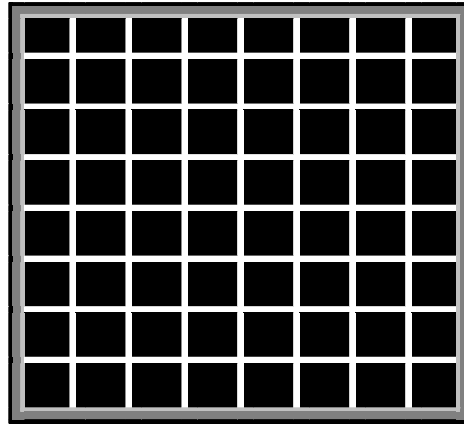

Inverted 8 × 8 cross hatch

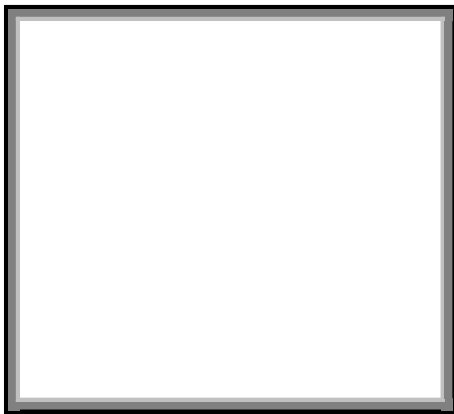

White Picture



Black Picture

The test pattern signal is generated when SELF and ENPAT are both set to “1”. This video signal will synchronize to the free-running Hsync and Vsync, no matter which frequency is chosen. The following diagram shows the timing relationship of cross hatch picture.

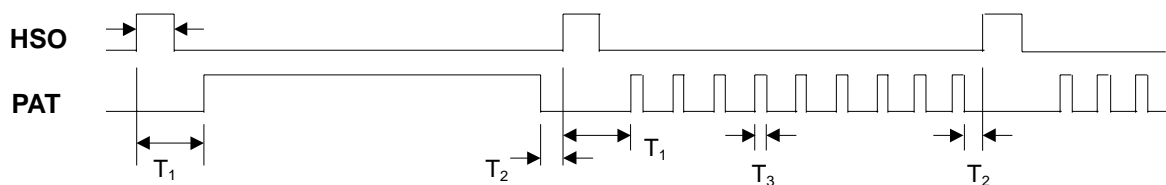

HSO	VSO	T <sub>1</sub>	T <sub>2</sub>	T <sub>3</sub>
31.1kHz	60.8Hz	6us	1us	62.5ns
47.9kHz	74.9Hz	5.125us	0.625us	62.5ns
64kHz	62.5Hz	3.625us	0.875us	62.5ns

## DDC Interface

The DDC interface is a slave mode I<sup>2</sup>C interface with DDC1 function. It is fully compatible with VESA DDC1/2B standard. The functional block diagram is shown in the below.

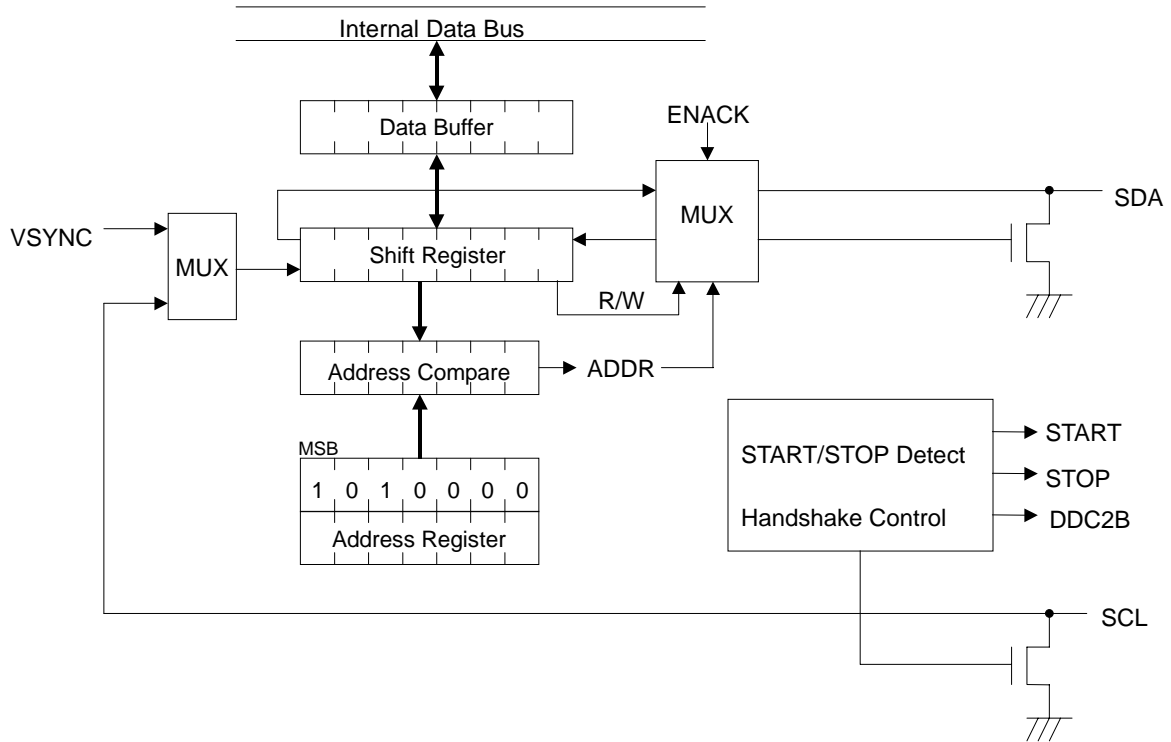

After power on or reset the DDC interface, it is in DDC1 state. The shift register shifts out data to SDA pin on the rising edge of VSYNC clock. Data format is an 8-bit byte followed by a null bit. Most significant bit (MSB) is transmitted first. Every time when the ninth bit has been transmitted, the shift register will load a data byte from data buffer (REG#18H). After loading data to the shift register, the data buffer becomes empty and generates an INT0 interrupt. So the program must write one data byte into REG#18 every nine VSYNC clocks.

Since the default values of data buffer (REG#22) and shift register are FFH, the SDA pin outputs high level if no data had been written into data buffer after power on reset. When program finished initialization and set the IEN\_D bit to "1", the INT0 will occur because the data buffer is empty. The INT0 service routine should check the DDC2B bit is "0" and then writes the first EDID data byte into data buffer. When the second INT0 occurs, the INT0 service routine writes the second EDID data byte into data buffer and so on.

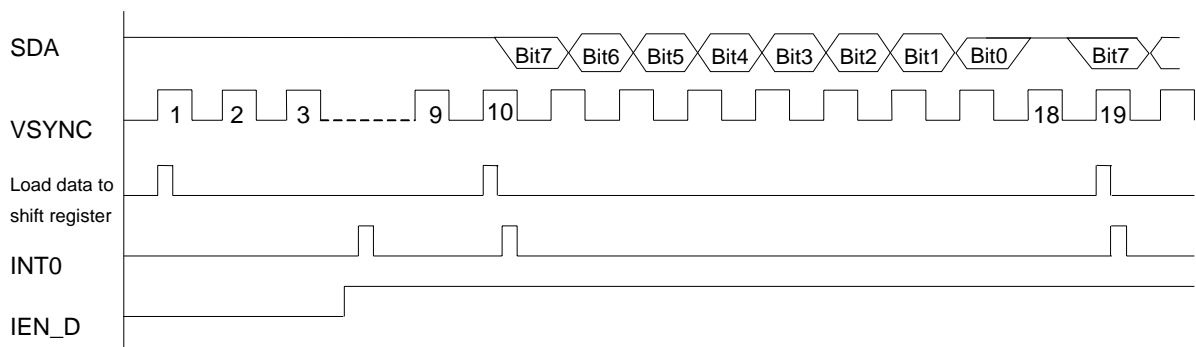

If a low level occurs on the SCL pin in DDC state, the DDC interface will switch to DDC2B state immediately and set the DDC2B bit to "1". No interrupt will be generated. But, if there is no valid device address and it receives 128 VSYNC pulses while the SCL is high level, it will lock into DDC2B state and disregard VSYNC.

In some case, program wants to go back DDC1 state, set RDDC bit in REG#1AH and reset it again. This operation resets the DDC interface to the initial condition.

When it is in DDC2B state, the VSYNC clock is disregarded and the communication protocol follows the DDC standard. The data format on SDA pin is:

S	Address	R/W	A	D7, D6, ..., D0	A	-----	D7, D6, ..., D0	A	P
---	---------	-----	---	-----------------	---	-------	-----------------	---	---

S: Start condition. A falling edge occurs when SCL is high level.

P: Stop condition. A rising edge occurs when SCL is high level.

A: Acknowledge bit. "0" means acknowledge and "1" means non-acknowledge.

Address: 7-bit device address.

R/W: Read/Write control bit, "1" is read and "0" is write.

D7, D6, ..., D0: data byte.

The hardware operations in DDC2B state are:

(1) START/STOP detection

When the START condition is detected, the DDC interface is enabled and set START bit to "1".

When the STOP condition is detected, the DDC interface is disabled, set STOP bit to "1" and generate INT0 interrupt.

The START bit is cleared when the following data byte received.

The STOP bit is cleared after writing REG#19H.

(2) Address Recognition

It contains two device addresses in WT6018. On fixed address ('1010000') is for EDID reading and one programmable address (REG#19H) is for external control, such as auto alignment.

If the address is equal to "1010000", set ADDR bit to "0".

If the address is equal to the bit A6 to bit A0 (REG#19H), set ADDR bit to "1".

If the address is not equal to anyone above, the DDC interface will not response acknowledge.

The ADDR bit is updated when a new device address is received.

(3) Store R/W bit and decide the direction of SDA pin

The R/W bit on the SDA pin will be stored in the RW bit.

(4) Acknowledge bit control/detection

Acknowledge bit control in receive direction:

If ENACK=1 and address compare is true, response acknowledge (Acknowledge bit ="0").

If ENACK=0 or address compare is false, response non-acknowledge (Acknowledge bit ="1").

Acknowledge bit detect in transmit direction:

If the acknowledge bit is "1", the DDC interface will be disabled and release the SDA pin.

If the acknowledge bit is "0", the DDC interface keeps on communicating.



(5) Data bytes transmit/receive

If the RW bit is “1”, the shift register will load data from the data buffer (REG#18H) before the data byte is transmitted and shift out data to the SDA pin before the rising edge of the SCL clock.

If the RW bit is “0”, the shift register will shift in data on the rising edge of the SCL clock and the whole data byte is latched to the data buffer (REG#18H).

(6) Handshaking procedure

The handshaking is done on the byte level. The DDC interface will hold the SCL pin low after the acknowledge bit automatically. The bus master will be forced to wait until the WT6018 is ready for the next byte transfer. To release the SCL pin, write REG#19H will release clear the wait state.

(7) Interrupt INTO

The DDC interface interrupt is enabled by setting the IEN\_D bit in the REG#1AH.

Interrupt INTO occurs when:

- Transmit buffer empty in DDC1 state.

The INTO occurs when the shift register load data from data buffer.

Write REG#18H will clear the transmit buffer empty condition.

- Acknowledge is detected in DDC2B state.

The INTO occurs on the falling edge of the SCL clock after the acknowledge had been detected.

The SCL pin will be pulled low to force the bus master to wait until the service routine write REG#19H.

- STOP condition occurs in DDC2B mode

Address	R/W	Initial	Bit7	Bit6	Bit5	Bit4	Bit3	Bit2	Bit1	Bit0
0018H	R/W	FFH	D7	D6	D5	D4	D3	D2	D1	D0
0019H	R	40H	DDC2B	ADDR	R/W	START	STOP	--	--	--
0019H	W	A0H	A6	A5	A4	A3	A2	A1	A0	ENACK

Bit Name	Bit value = “1”	Bit value = “0”
DDC2B	DDC2B state.	DDC1 state.
ADDR	Received address equals to the address in REG#19H(W).	Received address equals to ‘1010000’
RW	Received R/W bit is ‘1’	Received R/W bit is ‘0’
START	START condition is detected.	No START condition is detected.
STOP	STOP condition is detected.	No STOP condition is detected.
ENACK	Enable acknowledge.	Disable acknowledge.
A6, A5, ... , A0	7-bit slave address	
D7, D6, ... , D0	Data to be transmitted or received data.	

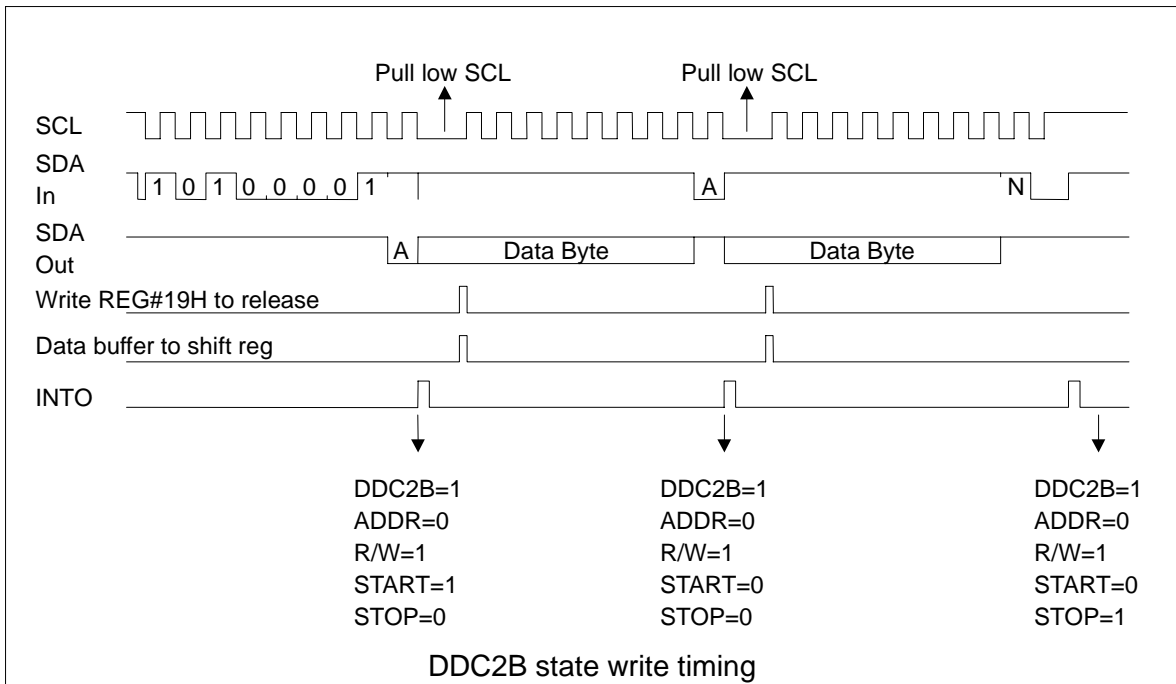
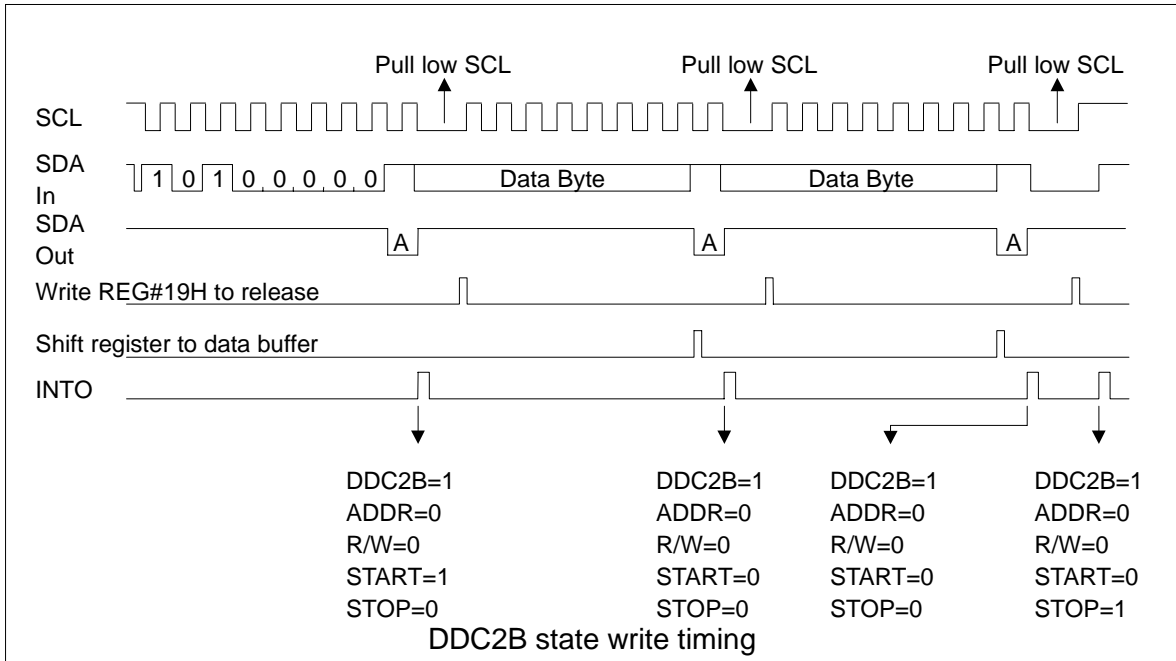

### 3. 2-wire serial CMOS EEROPM

#### Features

- Low Voltage and Standard Voltage Operation
  - 5.1 (V<sub>cc</sub> = 4.5 V to 5.5 V)
  - 3.0 (V<sub>cc</sub> = 2.7 V to 5.5 V)
  - 2.5 (V<sub>cc</sub> = 2.5 V to 5.5 V)
  - 2.0 (V<sub>cc</sub> = 1.8 V to 5.5 V)
- Internally Organized 128 x 8 (1K), 256 x 8 (2K), 512 x 8 (4K), 1024 x 8 (8K) or 2048 x 8 (16K)
- Two-wire Serial Interface
- Bidirectional Data Transfer Protocol
- Wire Protect Pin for Hardware Data Protection
- Eight-byte Page (1K, 2K), 16-byte Page (4K, 8K, 16K) Write Modes
- Partial Page Write Cycle (10 ms max)
- High Reliability
  - Endurance: 100,00 Cycles
  - Extended Endurance Devices Available
  - Data Retention: 100 years
- Automotive Grade and Extended Temperature Device Available
- Eight-Pin and 14-Pin JEDEC SOIC and Eight-Pin PDIP Packages

#### Description

The AT24C01A/02/04/08/16 provides 1024/2048/4096/8192/16384 bits of serial electrically erasable and programmable read only memory (EEPROM) organized as 128/256/512/1024/2048 words of 8 bits each. The device is optimized for use in many industrial and commercial applications where low power and low voltage operation are essential. The AT24C01A/02/04/08/16 is available in space saving eight-pin PDIP, eight-pin and fourteen-pin SOIC packages and is accessed via a two-wire serial interface. The AT24C01A/02/04/08/16 is guaranteed for 100,000 erase/wire cycles and 100 year data retention. In addition, the entire family is available in 5.0 V (4.5 V to 5.5 V), 3.0 V (2.7 V to 5.5 V), 2.5 V (2.5 V to 5.5 V) and 2.0 V (1.8 V to 5.5 V) versions.

#### Pin Configurations

Pin Name	Function
A <sub>0</sub> to A <sub>2</sub>	Address Inputs
SDA	Serial Data
SCL	Serial Clock Input
WP	Write Protect
NC	No Connect

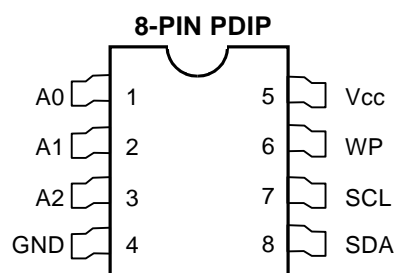
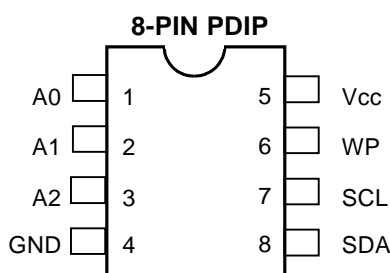
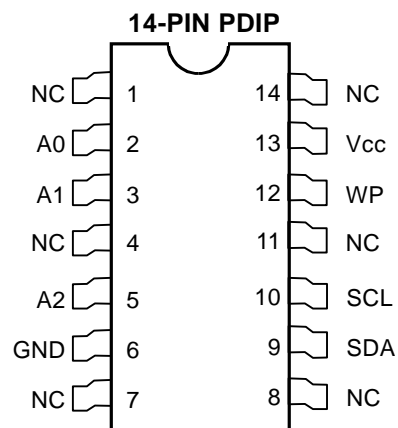

#### 4. Horizontal deflection signal processing

LM1290:

1. Full-automatic synchronization from 22 kHz to 90 kHz. No component changeover nor external adjustment is required.
2. DC control H phase and duty cycle.
3. The resistance corresponds to the frequency programmable down to VCO.
4. X-ray input invalid.
5. H-drive invalid due to low VCC (when  $V_{CC} < 9.5V$ ). The H OUT transistor is protected as a result.
6. The capacitor protects the H output transistor during the change of the scanning mode, by means of the programmable frequency ramming  $H VO/dt$ .

#### System Block Diagram

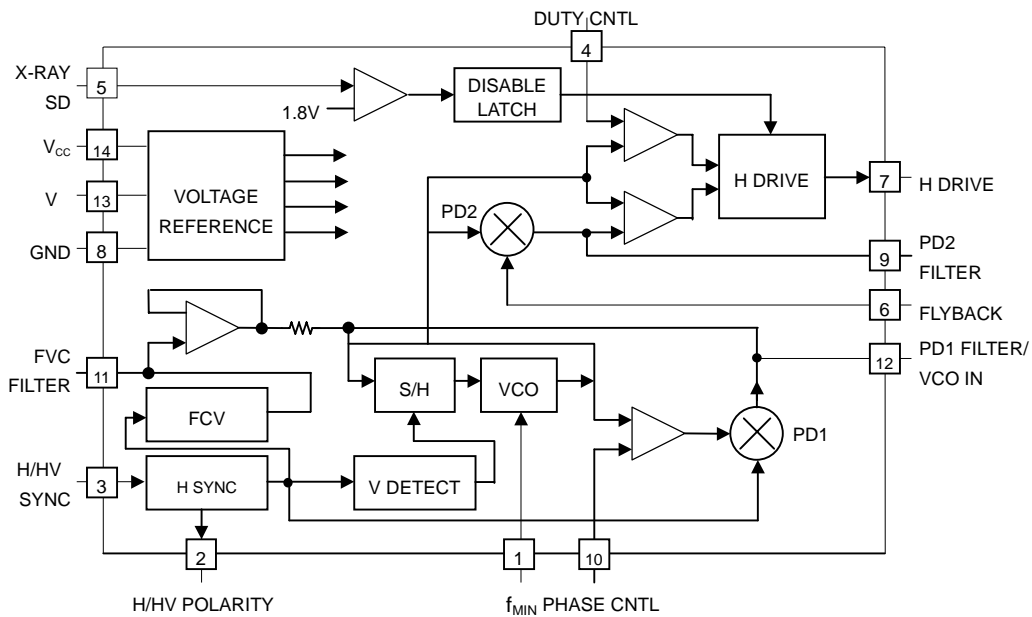

#### Typical Application LM1290

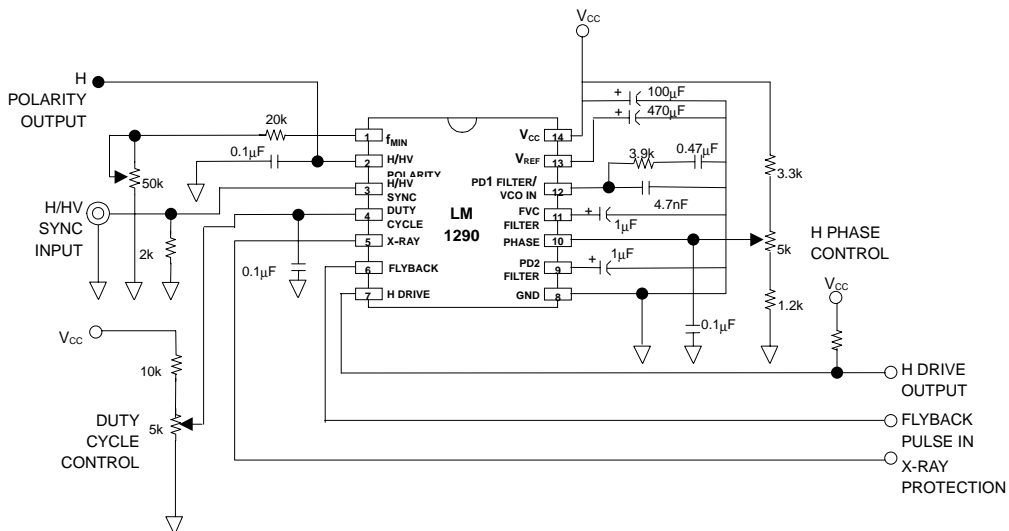

1. PIN 1.  $f_{min}$ : lower limit frequency of this setting.  $f_{min} = 5.6 \times 10^8 / (R_{min} * 500)$   
 $f_{min} = 29.1 \text{ kHz}$ ,  $R_{min} = 18.7 \text{ K}\Omega$  (When the frequency is 30kHz or more)  
 $f_{min} = 22.8 \text{ kHz}$ ,  $R_{min} = 24 \text{ K}\Omega$  (When the frequency is 24kHz or more)
2. PIN 2. Polarity of H/HV:  
 $C_{POL} = 0.1 \mu\text{f}$ ,  $I_o = \pm 1 \mu\text{A}$ ,  $V_o = 1 - e^{-t/RC}$
3. H/HV synchronous input:  
 When there is compatibility between TTL and CMOS, the H/HV synchronous input is within the 0.35 to 1.85 V range, and the polarity is negative.
4. Power factor control:  
 $V_4 = 0 \sim 4\text{V} = 70 \text{ to } 30\%$ ,  $10\%/V$   
 $V_4 = (V_{ref} * R_1) / R_2 = 2.17\text{V}$   
 $\text{Duty} = (2.17 * 10\%/V) + 30\% = 51.7 \text{ to } 56.7\%$
5. X-ray shutdown:  
 Specification: 1.65 to 1.8V shutdown  
 When  $B+ \text{ HV} = 25 \text{ kV}$ , we have  $V_{out} = 25 V_{DC}$ , therefore, when shutdown  $\text{HV} = 27.5 \text{ kV}$ , we have  $V_{out} = 30.8 V_{DC}$ .  
 When  $R_1 = 10.7 \text{ K}\Omega$  and  $R_2 = 10 \text{ K}\Omega$ , we have shutdown  $V_{OL} = 26.8 \text{ to } 28.2 \text{ KV}$ .
6. Fly-back input threshold voltage:  
 $10 V_{p-p} < V_{in}$ ,  $V_{cc} (12\text{V}) R_{484} = 24 \text{ K}\Omega$ ,  $V_{in} = 11 V_{p-p}$ .
7. Horizontal drive:  
 Low level current: Minimum 100mA  
 Low level voltage: Maximum 0.4V  
 $48.36 \text{ KHz}$ :  $T_{on} = 11.01 \mu\text{s}$ ,  $T_{off} = 9.66 \mu\text{s}$  : 53.28%
8. Pin 10 H-PHASE control:  
 Control gain = 8.89% TH/V  
 Minimum control ROMGE =  $\pm 22\% T_N$   
 $V_{10} = 3.8 \sim 6.8\text{V}$   $f = 31.5 \text{ kHz}$ , Range =  $\pm 7.9 \mu\text{s}$   
 $f = 64 \text{ kHz}$ , Range =  $\pm 3.9 \mu\text{s}$
9.  $V_{ref}$ :  $V_{ref}$  specification = 8.2  $V_{DC}$
10. FVC filter:  
 $FVC = 0.052 \text{ V/kHz}$   $V_{11} \text{ } 31.5 \text{ KHz to } 64 \text{ KHz} = 1.734 \text{ to } 3.53\text{V}$

5. Vertical compensation and geometrical compensation of the raster

LM1295:

1. Vertical scanning frequency : 50 to 100Hz.
2. DC control compensation amplitude
3. Temperature stability of the vertical amplitude : 1%.
4. Dynamic vertical deflection compensation corresponding to the secondary anode voltage drop.
5. Positive and negative compensation signals.

**Block Diagram**

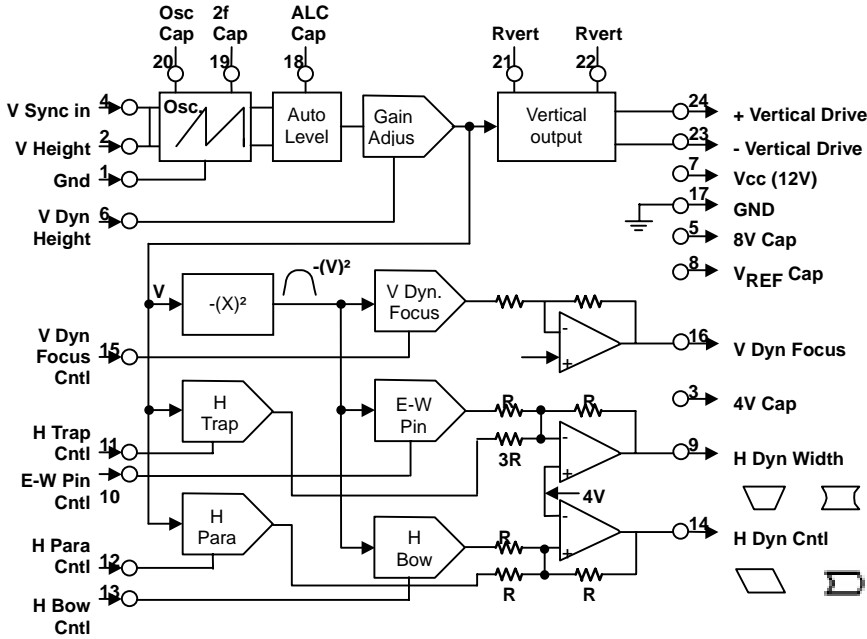

LM1295 Application

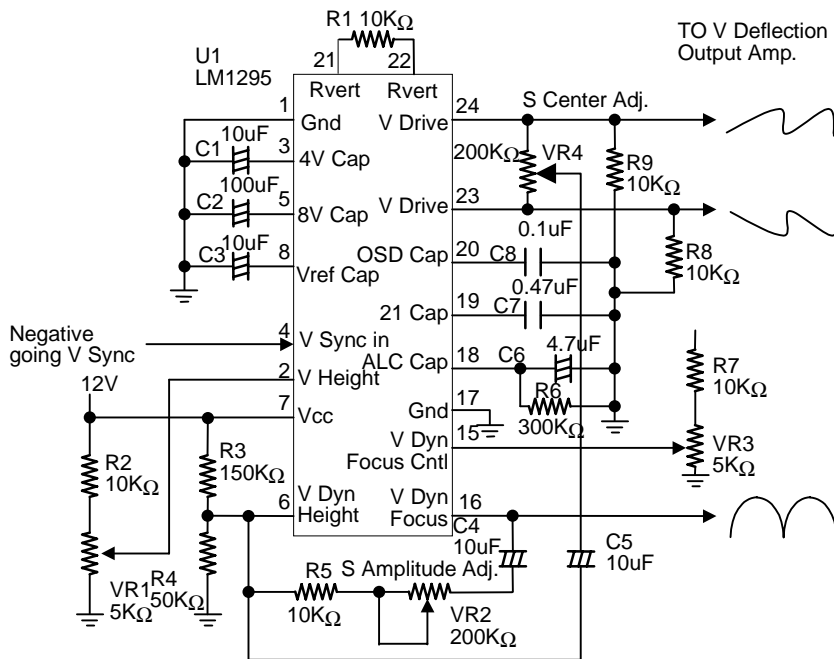

1. V-Height (Pin-2):  
The amplitudes of the +V and –V drive currents are controlled by means of the 0V to 4V voltage of this pin. The current can be raised by raising the voltage. The control range is approximately 1.8 to 1.
2. 4V CAP (Pin 3):  
4 V CAP (capacitor), 10 uF capacitor.
3. V-Sync in:  
The vertical synchronization input is a negative TTL level pulse, and it has the function of locking the vertical oscillator. The pulse has a minimum width of approximately 200 nS.
4. 8V CAP (Pin 5):  
8V CAP (capacitor), 100uF capacitor.
5. V-Dyn Height (Pin 6):  
The amplitude of the driving currents of the voltages +V and –V are controlled by means of the 3V to 4V voltage of this pin.
6. H-Dyn Height (Pin 9):  
This output is expressed by the sum of the vertical ramp and the parabola resulting from that ramp. The amplitude and the polarity of the ramp signal is controlled by H TRAP CNTRL (Pin 11), and the amplitude and polarity of the parabola is controlled by E-W PIN CNTRL (PIN 10), both in the DC-control mode.
7. E-W PIN CNTRL (Pin 10):  
This is the E-W direction pincushion deformation control function, and the voltage range is within the 0V-4V range. When the voltage falls within the 2V-4V range, the amplitude increases, and the parabola becomes positive. On the other hand, when the voltage falls within the 2V-0V range, the parabola becomes negative.
8. TRAP CNTRL (Pin 11):  
This is the trapezoid control function, and the voltage is within the 0V-4V range. When the voltage falls within the 2V-4V range, the amplitude increases, and the ramp becomes positive. On the other hand, when the voltage falls within the 0V-2V range, the ramp becomes negative.
9. Parallelogram control (Pin 12):  
The voltage is within the 0V to 4V range. When the voltage falls within the 2V-4V range, the ramp, the ramp becomes positive.  
One the other hand, when the voltage falls within the 0V-2V range, the ramp becomes negative.
10. Bow shape control (Pin 13):  
The voltage is within the 0V-4V range. When the voltage falls within the 2V-4V range, the parabola becomes positive. On the other hand, when the voltage falls within the 0V-2V range, the parabola becomes negative.

11. Output of the parabola and bow-shaped parabola (Pin 14):

The amplitude and the polarity of the ramp signal are controlled by means of the PARA CNTRL (Pin 12), and the amplitude and polarity of the parabola are controlled by the BOW CNTRL (PIN 13).

In both cases, the control is carried out in the DC mode.

12. V Dyn Focus control (Pin 15):

The voltage is within the 0V to 4V range. When the voltage falls within the 2V-4V range, the parabola becomes positive. On the other hand when the voltage falls within the 0V-2V range, the parabola becomes negative.

13. V Dyn Focus (Pin 16)

14. ALC Cap (Pin 18):

This is the Automatic level Controller (ALC) capacitor, and the recommended value is 4.7 uF.

15. Frequency doubling capacitor:

This is the vertical oscillator that locks at a frequency twice as high as the vertical synchronization frequency. Its capacitance is 0.47 uF.

16. OSC Cap (Pin 20):

The value of the capacitance is 0.1 uF.

17. Rvert (Pin 21/22):

The vertical resistor has the function of determining the gain of the vertical ramp current generator.

18. -V drive (Pin 23) and +V drive (PIN 24):

-V is the negative portion of the vertical ramp output current of the object of the operation.

The ramp current waveform is superimposed on the DC current of the approximately 315 uA.

The voltage corresponding to the output (typically 10 k $\Omega$ ) is typically 6V.



6. Horizontal drive and power supply output

**Circuit Diagram**

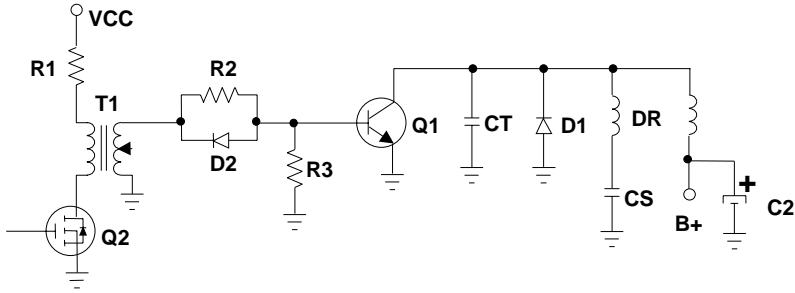

**Description of the circuit:**

- 1) R1, T1 and Q2 compose the horizontal driving circuit, and the transistor Q1 generates a horizontal output through the driving signal.

$$I_{B1} = I_{CPMAX} / Q1h_{feMIN}$$

$$I_{B2} \approx 3I_{B1}$$

$$di/dt \approx 3.3 A/\mu s$$

- 2) The resistor R2 corrects the current  $I_{B1}$ , the resistor R3 works as a damping resistor and leak resistor, and the diode D2 works as a discharging device and polar body. As long as the transistor Q1 is OFF, the discharge is accelerated and the storage time ( $T_{stg}$ ) is shortened.
- 3) H-OUT circuit waveform

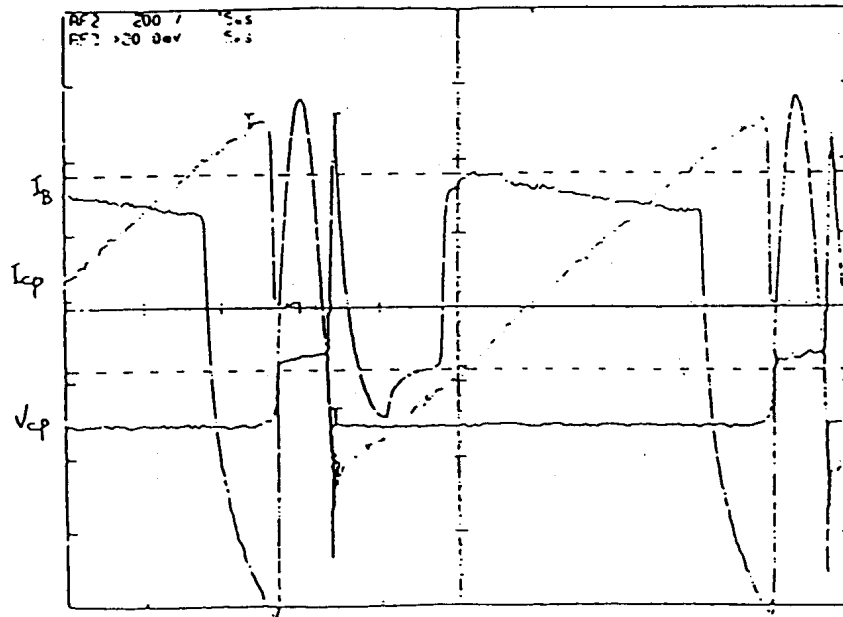

Time 5uS/div

## 7. Horizontal amplitude control

### Circuit Diagram

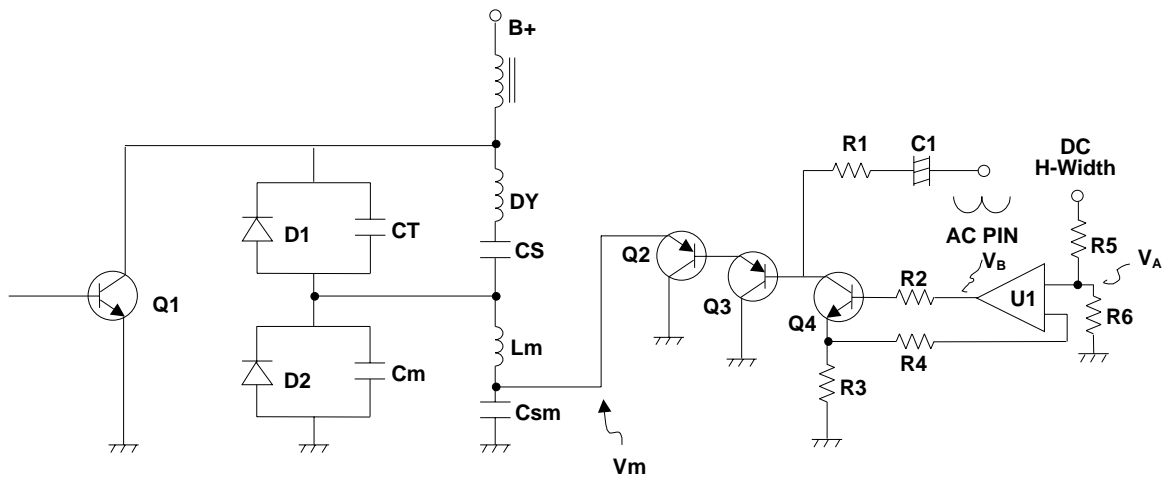

### Description of the circuit:

- 1) The diodes D1 and D2 compose the bipolar modulation circuit, and have the function of controlling the currents of the coils DY ( $I_{pp}$ ) and  $L_m$  ( $I_m$ ) through voltage modulation carried out by utilizing VM.

$$B+ = V_m + V_{cs} \quad \text{Therefore, } V_{cs} = (I_y * L_y) / t_s \rightarrow I_y = (V_{cs} * t_s) / L_y, \text{ with } B+ \text{ fixed.}$$

Such being the case, the horizontal width decreases when  $V_m \uparrow \rightarrow V_{cs} \downarrow \rightarrow I_y \downarrow$

Inversely, the horizontal width increases when  $V_m \downarrow \rightarrow V_{cs} \uparrow \rightarrow I_y \uparrow$

$$(B+ = (V_p * 2T_r) / (\pi * T_s), T_r = \sqrt{L_y C_t}, T_m = \sqrt{L_m C_m})$$

- 2) Q2, Q3, Q4 and U1 compose the control circuit of H-WIDTH. Of those devices, the transistor Q1 and Q2 compose the Darlington current amplifier, and on the other hand the transistor Q4 and the operational amplifier U1 compose the emitter-coupled circuit, that stabilize the voltage and control the current.
- 3) The horizontal width broadens when  $V_a \uparrow \rightarrow V_{bl} \uparrow \rightarrow I_1 \uparrow \rightarrow I_2 \uparrow \rightarrow V_m \downarrow \rightarrow$ . An inference in the opposite sense is also possible.

### Test points for maintenance:

- 1)  $C_T = 31 \text{ to } 37 \text{ kHz} = 3.2 \text{ us}$

$$48 \text{ to } 64 \text{ kHz} = 3.0 \text{ us}$$

$$C_m \div 2.8 \text{ us}$$

- 2)  $V_{A\_CENTER}: 31 \text{ to } 64 \text{ kHz } \approx 1.91 \text{ to } 4.06V$

$$V_{M\_CENTER}: 31 \text{ to } 64 \text{ kHz } \approx 11.6 \text{ to } 27.4V$$

## 8. Blanking and spot killer

### Circuit Diagram

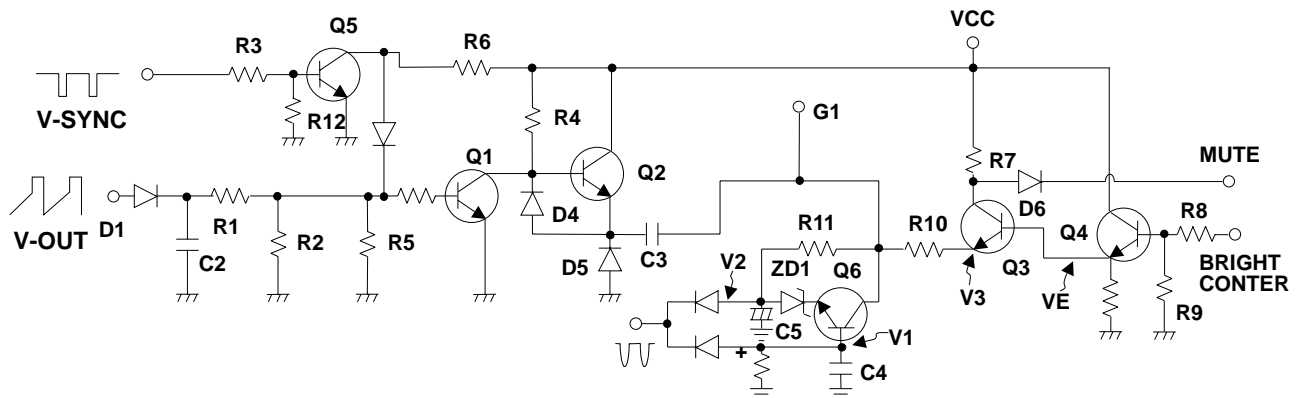

### Description of the circuit:

- 1) The vertical blanking circuit completes by Q1, Q2, Q3 and peripheral circuit.  
The vertical sync pulse applied to R3, R12 connected to Q5 base. Q5 is invert amplifier, then mixer with Q1 base together for compensate vertical retrace time of the blanking pulse.
- 2) The vertical amplifier output waveform through D1, C2, R1, R2 make waveform forming and clamp. Then applied to Q1 base, the vertical blanking amplifier of the Q1, the output connected to buffer Q2, through C3 coupling to G1 control circuit. D4, D5 for over voltage protect.
- 3) The Q6 is spot killer protect circuit, in normal power on stage.  
 $V1 = V2$  and ZD1, so Q6 off. The CRT G1 voltage is fixed at  $-45 \sim -67\text{VDC}$  with vertical blanking pulse  $12\text{Vpp}$   $V_{G1} = -(V \times R11) / (R10 + R11)$ , ( $V = V1 - V3$ ).  
When power off the voltage  $V1 > V2$ , then Q6 turn on pulling  $V_{G1}$  to  $-180\text{V}$  to protect CRT.
- 4) When Mute set to lower the Q3 off  $G1 = -180\text{V}$  screen cut off no picture display, this mute circuit makes active, at power ON/OFF and when mode change stage.
- 5) Q4 bias set up by MCU to control the  $V_{CE}$  bias of Q3, then control G1 voltage output.

### Test points for maintenance:

- 1) Check D1, R3 and Q1 collector
- 2) G1 voltage control range =  $-45 \sim -67\text{VDC}$   
G1 off momentary voltage  $\approx -180\text{VAC}$

9. Video amplifier system with on-screen display

LM1281 (U201)

Outstanding features:

- \* Three-channel video amplifier bandwidth 85 MHz @ -3 dB (4 Vp-p output)
- \* OSD TTL input, bandwidth 50 MHz
- \* High-speed video/OSD changeover
- \* High impedance DC contrast control above the 0-4V, 40dB range
- \* High impedance DC OSD contrast control above the 0-4V, 40dB range

**BLOCK AND CONNECTION DIAGRAM**

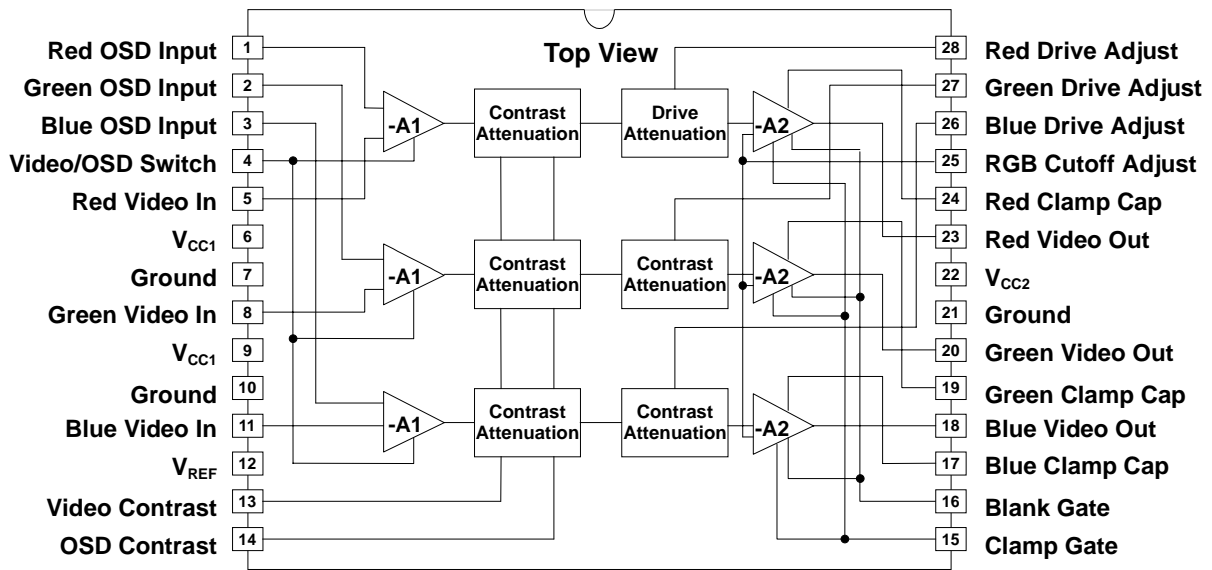

Description of the functions

Figure 1 shows the block diagram of LM1281, in conformity with the pin layout of the IC.

Every channel accepts both the video signal and the OSD signal at the input amplifier (A1).

Also the video/OSD changeover signal passes either the video signal or the OSD signal through LM1281, or is connected with the input amplifier for control purposes. The next contrast adjustment block is a drive adjustment type one.

The reference level for the DC return circuit is set by means of the RGB cutoff adjustment pin (PIN 25).

Attention must be paid to the fact that the blank clamp gate is active when it is stuck at the LOW state.

Under ordinary circumstances, these pins are controlled by means of the standard TTL signal.

Test Circuits

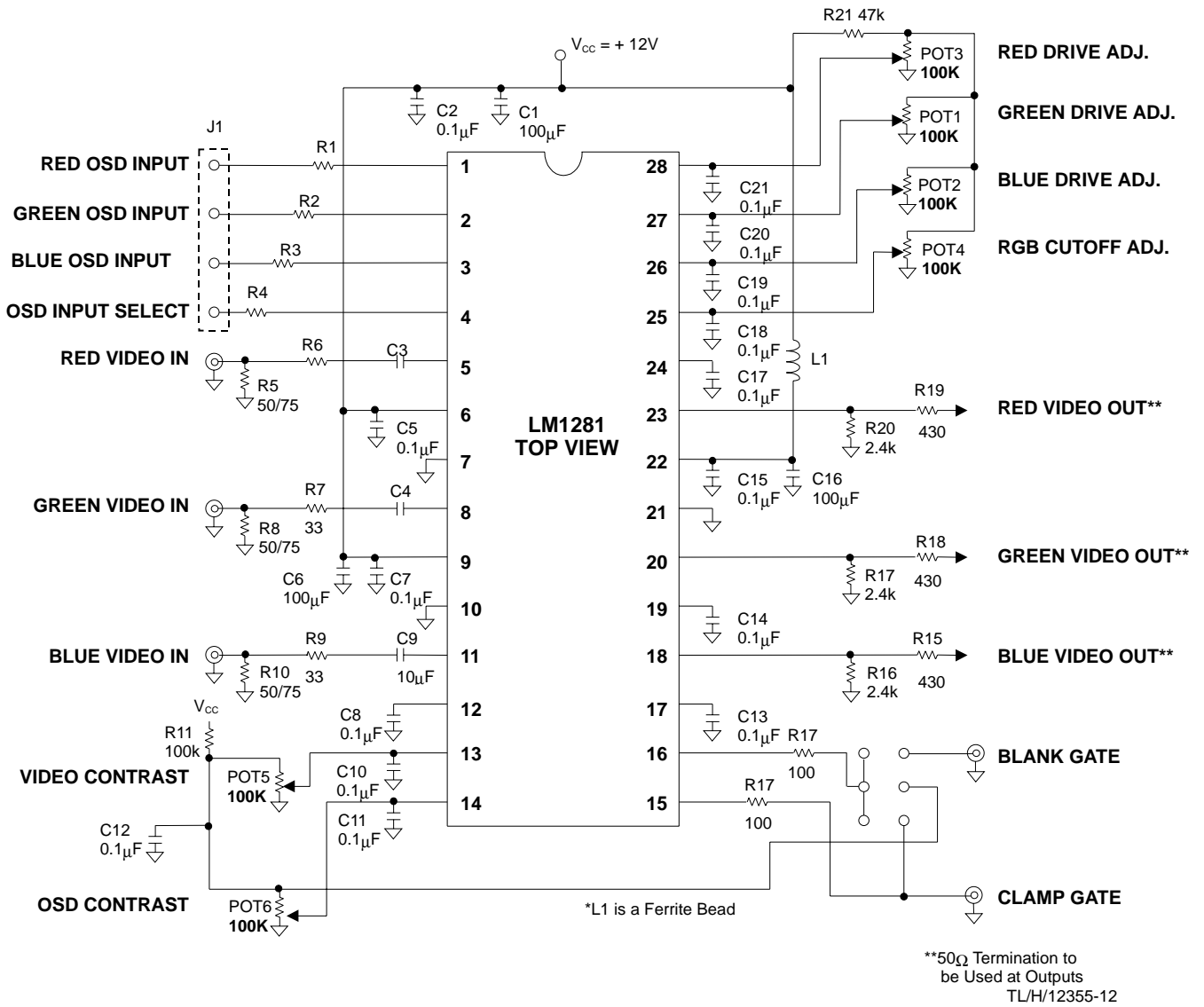
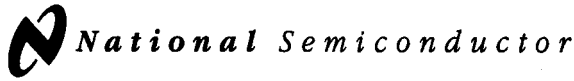

FIGURE 2 LM1281 OSD Video Preamp Demonstration Board Schematic



August 1999

# LM2438 Monolithic Triple 13.5 ns CRT Driver

## General Description

The LM2438 is an integrated high voltage CRT driver circuit designed for use in color monitor applications. The IC contains three high input impedance, wide band amplifiers which directly drive the RGB cathodes of a CRT. Each channel has its gain internally set to -14 and can drive CRT capacitive loads as well as resistive loads present in other applications, limited only by the package's power dissipation. The IC is packaged in an industry standard 9-lead TO-220 molded plastic power package. See Thermal Considerations section.

## Features

- Well matched with LM1279 video preamp
- 0V to 5V input range
- Stable with 0–20 pF capacitive loads and inductive peaking networks
- Convenient TO-220 staggered lead package style
- Standard LM243X Family Pinout which is designed for easy PCB layout

## Applications

- 1024 x 768 displays up to 60 Hz refresh
- Pixel clock frequencies up to 60 MHz
- Monitors using video blanking

## Schematic and Connection Diagrams

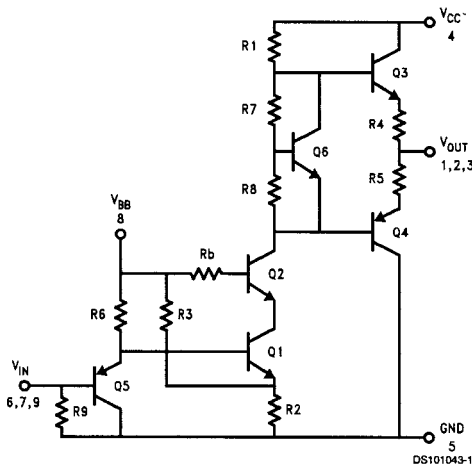
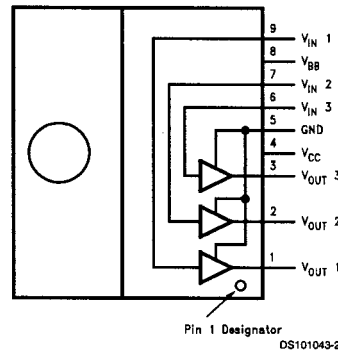

FIGURE 1. Simplified Schematic Diagram (One Channel)



Note: Tab is at GND

Top View  
Order Number LM2438T

LM2438 Monolithic Triple 13.5 ns CRT Driver

## Theory of Operation

The LM2438 is a high voltage monolithic three channel CRT driver suitable for high resolution display applications. The LM2438 operates with 80V and 12V power supplies. The part is housed in the industry standard 9-lead TO-220 molded plastic power package.

The circuit diagram of the LM2438 is shown in *Figure 1*. The PNP emitter follower, Q5, provides input buffering. Q1 and Q2 form a fixed gain cascode amplifier with resistors R1 and R2 setting the gain at -14. Emitter followers Q3 and Q4 isolate the high output impedance of the cascode stage from the capacitance of the CRT cathode which decreases the sensitivity of the device to load capacitance. Q6 provides biasing to the output emitter follower stage to reduce cross-over distortion at low signal levels.

*Figure 2* shows a typical test circuit for evaluation of the LM2438. This circuit is designed to allow testing of the LM2438 in a 50Ω environment without the use of an expensive FET probe. In this test circuit, the two 2.49 kΩ resistors form a 200:1 wideband, low capacitance probe when connected to a 50Ω coaxial cable and a 50Ω load (such as a 50Ω oscilloscope input). The input signal from the generator is ac coupled to the base of Q5.

## Application Hints

### INTRODUCTION

National Semiconductor (NSC) is committed to provide application information that assists our customers in obtaining the best performance possible from our products. The following information is provided in order to support this commitment. The reader should be aware that the optimization of performance was done using a specific printed circuit board designed at NSC. Variations in performance can be realized due to physical changes in the printed circuit board and the application. Therefore, the designer should know that component value changes may be required in order to optimize performance in a given application. The values shown in this document can be used as a starting point for evaluation purposes. When working with high bandwidth circuits, good layout practices are also critical to achieving maximum performance.

### IMPORTANT INFORMATION

The LM2438 performance is targeted for the XGA (1024 x 768, 60 Hz refresh) resolution market. The application circuits shown in this document to optimize performance and to protect against damage from CRT arcover are designed specifically for the LM2438. If another member of the LM243X family is used, please refer to its datasheet.

### POWER SUPPLY BYPASS

Since the LM2438 is a wide bandwidth amplifier, proper power supply bypassing is critical for optimum performance. Improper power supply bypassing can result in large overshoot, ringing or oscillation. 0.1 μF capacitors should be connected from the supply pins, V<sub>CC</sub> and V<sub>BB</sub>, to ground, as close to the LM2438 as is practical. Additionally, a 47 μF or larger electrolytic capacitor should be connected from both supply pins to ground reasonably close to the LM2438.

### ARC PROTECTION

During normal CRT operation, internal arcing may occasionally occur. Spark gaps, in the range of 200V, connected from the CRT cathodes to CRT ground will limit the maximum volt-

age, but to a value that is much higher than allowable on the LM2438. This fast, high voltage, high energy pulse can damage the LM2438 output stage. The application circuit shown in *Figure 9* is designed to help clamp the voltage at the output of the LM2438 to a safe level. The clamp diodes, D1 and D2, should have a fast transient response, high peak current rating, low series impedance and low shunt capacitance. FDH400 or equivalent diodes are recommended. Do not use 1N4148 diodes for the clamp diodes. D1 and D2 should have short, low impedance connections to V<sub>CC</sub> and ground respectively. The cathode of D1 should be located very close to a separately decoupled bypass capacitor (C3 in *Figure 9*). The ground connection of D2 and the decoupling capacitor should be very close to the LM2438 ground. This will significantly reduce the high frequency voltage transients that the LM2438 would be subjected to during an arcover condition. Resistor R2 limits the arcover current that is seen by the diodes while R1 limits the current into the LM2438 as well as the voltage stress at the outputs of the device. R2 should be a ½W solid carbon type resistor. R1 can be a ¼W metal or carbon film type resistor. Having large value resistors for R1 and R2 would be desirable, but this has the effect of increasing rise and fall times. Inductor L1 is critical to reduce the initial high frequency voltage levels that the LM2438 would be subjected to. The inductor will not only help protect the device but it will also help minimize rise and fall times as well as minimize EMI. For proper arc protection, it is important to not omit any of the components shown in *Figure 9*.

## Application Hints (Continued)

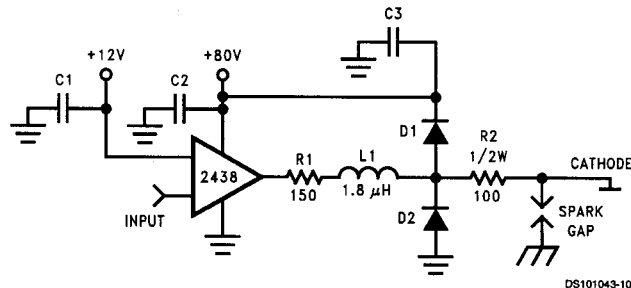

FIGURE 9. One Channel of the LM2438 with the Recommended Application Circuit

### OPTIMIZING TRANSIENT RESPONSE

Referring to *Figure 9*, there are three components ( $R_1$ ,  $R_2$  and  $L_1$ ) that can be adjusted to optimize the transient response of the application circuit. Increasing the values of  $R_1$  and  $R_2$  will slow the circuit down while decreasing overshoot. Increasing the value of  $L_1$  will speed up the circuit as well as increase overshoot. It is very important to use inductors with very high self-resonant frequencies, preferably above 300 MHz. Ferrite core inductors from J.W. Miller Magnetics (part #78F1R8K) were used for optimizing the performance of the device in the NSC application board. The values shown in *Figure 9* can be used as a good starting point for the evaluation of the LM2438. Using a variable resistor for  $R_1$  will simplify finding the value needed for optimum performance in a given application. Once the optimum value is determined the variable resistor can be replaced with a fixed value.

### EFFECT OF LOAD CAPACITANCE

*Figure 8* shows the effect of increased load capacitance on the speed of the device. This demonstrates the importance of knowing the load capacitance in the application. *Figure 8* also shows the effect inductance has on the rise and fall times.

### EFFECT OF OFFSET

*Figure 7* shows the variation in rise and fall times when the output offset of the device is varied from 40 to 50  $V_{DC}$ . The rise time shows a maximum variation relative to the center data point (45  $V_{DC}$ ) of about 2%. The fall time shows a variation of about 2% relative to the center data point.

### THERMAL CONSIDERATIONS

*Figure 4* shows the performance of the LM2438 in the test circuit shown in *Figure 2* as a function of case temperature. The figure shows that the rise time of the LM2438 increases by approximately 5% as the case temperature increases from 50°C to 100°C. This corresponds to a speed degradation of 1% for every 10°C rise in case temperature. The fall time increases by approximately 7.5% as the case temperature increases from 50°C to 100°C. This corresponds to a speed degradation of 1.5% for every 10°C rise in case temperature.

*Figure 6* shows the maximum power dissipation of the LM2438 vs. Frequency when all three channels of the device are driving an 8 pF load with a 40  $V_{p-p}$  alternating one pixel on, one pixel off signal. The graph assumes a 72% active time (device operating at the specified frequency) which is typical in a monitor application. The other 28% of the time

the device is assumed to be sitting at the black level (65V in this case). This graph gives the designer the information needed to determine the heat sink requirement for his application. The designer should note that if the load capacitance is increased the AC component of the total power dissipation will also increase.

The LM2438 case temperature must be maintained below 100°C. If the maximum expected ambient temperature is 70°C and the maximum power dissipation is 2.6W (from *Figure 6*, 30 MHz bandwidth) then a maximum heat sink thermal resistance can be calculated:

$$R_{TH} = \frac{100^{\circ}\text{C} - 70^{\circ}\text{C}}{2.6\text{W}} = 11.5^{\circ}\text{C/W}$$

This example assumes a capacitive load of 8 pF and no resistive load.

### TYPICAL APPLICATION

A typical application of the LM2438 is shown in *Figure 11*. Used in conjunction with an LM1279, a complete video channel from monitor input to CRT cathode can be achieved. Performance is ideal for 1024 x 768 resolution displays with pixel clock frequencies up to 60 MHz. *Figure 11* is the schematic for the NSC demonstration board that can be used to evaluate the LM1279/2438 combination in a monitor.

### PC BOARD LAYOUT CONSIDERATIONS

For optimum performance, an adequate ground plane, isolation between channels, good supply bypassing and minimizing unwanted feedback are necessary. Also, the length of the signal traces from the preamplifier to the LM2438 and from the LM2438 to the CRT cathode should be as short as possible. The following references are recommended:

Ott, Henry W., "Noise Reduction Techniques in Electronic Systems", John Wiley & Sons, New York, 1976.

"Video Amplifier Design for Computer Monitors", National Semiconductor Application Note 1013.

Pease, Robert A., "Troubleshooting Analog Circuits", Butterworth-Heinemann, 1991.

Because of its high small signal bandwidth, the part may oscillate in a monitor if feedback occurs around the video channel through the chassis wiring. To prevent this, leads to the video amplifier input circuit should be shielded, and input circuit wiring should be spaced as far as possible from output circuit wiring.



## Application Hints (Continued)

### NSC DEMONSTRATION BOARD

Figure 12 shows the routing and component placement on the NSC LM1279/2438 demonstration board. The schematic of the board is shown in Figure 11. This board provides a good example of a layout that can be used as a guide for future layouts. Note the location of the following components:

- C54, C56 —  $V_{CC}$  bypass capacitor, located very close to pin 4 and ground pins
- C43, C44 —  $V_{BB}$  bypass capacitors, located close to pin 8 and ground
- C53, C55 — Additional  $V_{CC}$  bypass capacitors, near LM2438 and  $V_{CC}$  clamp diodes. Very important for arc protection.

The routing of the LM2438 outputs to the CRT is very critical to achieving optimum performance. Figure 13 shows the routing and component placement from pin 1 of the LM2438

to the red cathode. Note that the components are placed so that they almost line up from the output pin of the LM2438 to the red cathode pin of the CRT connector. This is done to minimize the length of the video path between these two components. Note also that D16, D17, R21 and D9 are placed to minimize the size of the video nodes that they are attached to. This minimizes parasitic capacitance in the video path and also enhances the effectiveness of the protection diodes. The anode of protection diode D17 is connected directly to a section of the the ground plane that has a short and direct path to the LM2438 ground pins. The cathode of D16 is connected to  $V_{CC}$  very close to decoupling capacitor C53 (see Figure 13) which is connected to the same section of the ground plane as D17. The diode placement and routing is very important for minimizing the voltage stress on the LM2438 during an arc-over event. Lastly, notice that S1 is placed very close to the red cathode and is tied directly to CRT ground.

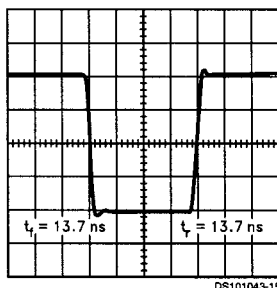

FIGURE 10. Waveform at Cathode with LM1279/243X Demo Board

## 11. On Screen Display

### FEATURES

- Horizontal sync input may be up to 100 kHz.
- On-chip PLL circuitry up to 90MHz pixel rate for multi-sync operation.
- Programmable horizontal resolutions up to 1524 dots per display row.
- 538 bytes display registers to control full screen display.
- Full screen display consists of 10 (rows) by 24 (columns) characters.
- 12 × 18 dot matrix per character.
- 128 built-in characters and graphic symbols and character by character color selection.
- Maximum 8 color selectable per display row.
- Double character height and/or width control.
- Programmable positioning for display screen center.
- Bordering and shadowing effect for display.
- Programmable vertical character height (18 to 71 lines) for multi-sync operation.
- 4 programmable background windows with multi-level windowing effect.
- Software clear function for display frame buffer.
- Hsync and Vsync input polarity selectable.
- Auto detection for input edge distortion between Hsync and Vsync inputs.
- Half tone and fast blanking output.
- Software force blank function for display frame.
- Compatible with both SPI bus and I<sup>2</sup>C interface through pin selection.
- 16 pins PDIP package.

### GENERAL DESCRIPTION

MTV016 is designed for use in monitor applications to display the built-in characters or symbols onto monitor screen. The display operation is by transferring data and control information in micro controller to RAM through a serial data interface. It can execute full screen display automatically and specific functions such as character bordering, shadowing, double height and width, font by font color control, frame positioning, frame size control by character height and horizontal display resolution, and windowing effect.

### BLOCK DIAGRAM

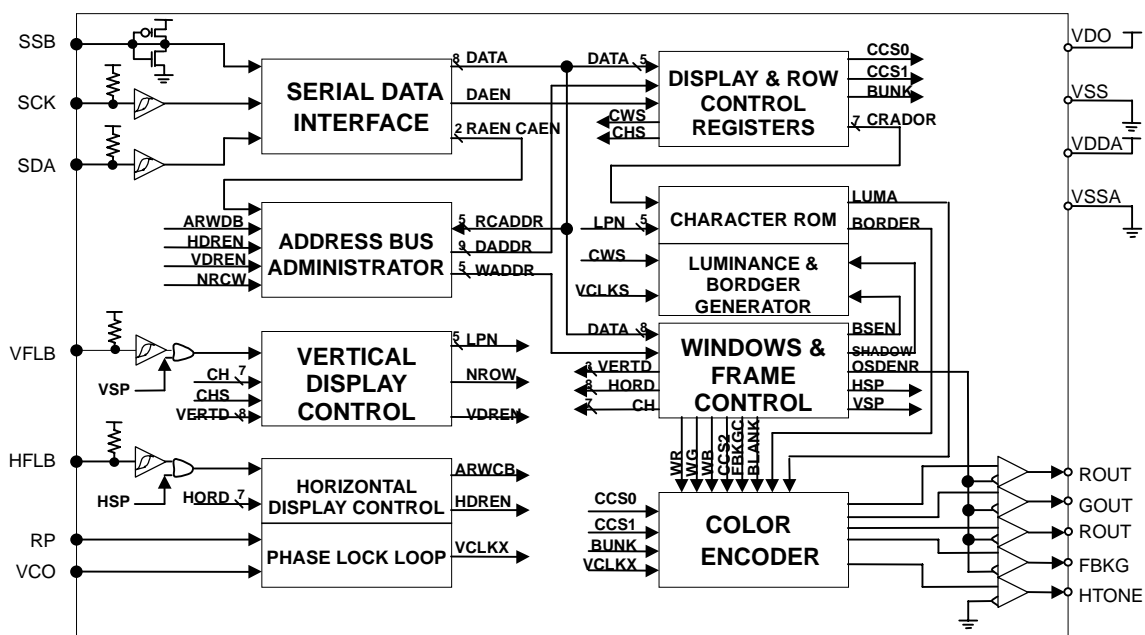

## 1.0 CONNECTION DIAGRAM

(16 PINS PDIP 300 MIL PACKAGE)

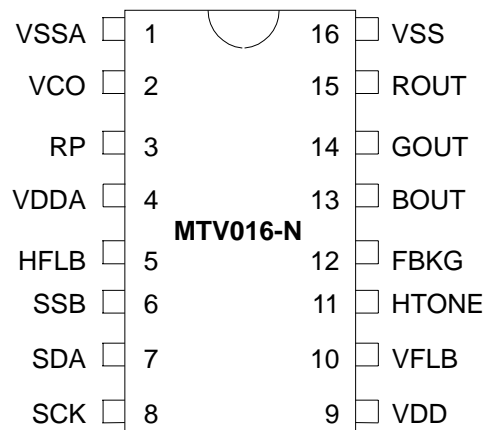

## 2.0 PIN DESCRIPTIONS

Name	I/O	Pin#	Function
VSSA	-	1	<b>Analog ground.</b> This ground pin is used to internal analog circuitry.
VCO	I/O	2	<b>Voltage Control Oscillator.</b> This pin is used to control the internal oscillator frequency by DC voltage input from external low pass filter.
RP	I/O	3	<b>Bias Resistor.</b> The bias resistor is used to regulate the appropriate bias current for internal oscillator to resonate at specific dot frequency.
VDDA	-	4	<b>Analog power supply.</b> Positive 5 V DC supply for internal analog circuitry. And a 0.1uF decoupling capacitor should be connected across to VDDA and VSSA.
HFLB	I	5	<b>Horizontal input.</b> This pin is used to input the horizontal synchronizing signal. It has an internal 100 kΩ pull-up resistor.
SSB	I	6	<b>Serial interface enable.</b> It is used to enable the serial data interface and is also used to select I <sup>2</sup> C or SPI bus operation. If this pin is left floating, I <sup>2</sup> C bus is enable. Otherwise the SPI bus is enabled.
SDA	I	7	<b>Serial data input.</b> The external data transfer through this pin to internal display registers and control registers. It has an internal 100 kΩ pull-up resistor.
SCK	I	8	<b>Serial clock input.</b> The clock input pin is used to synchronize the data transfer. It has an internal 100 kΩ pull-up resistor.
VDD	-	9	<b>Digital power supply.</b> Positive 5 V DC supply for internal digital circuitry and a 0.1uF decoupling capacitor should be connected across to VDD and VSS.
VFLB	I	10	<b>Vertical input.</b> This pin is used to input the vertical synchronizing signal. It has an internal pull-up resistor.
HTONE	O	11	<b>Half tone output.</b> This pin is used to attenuate the external R, G, B amplifiers gain for the transparent windowing effect.
FBKG	O	12	<b>Fast Blanking output.</b> It is used to cut off the external R, G, B signals while this chip is displaying characters or windows.
BOUT	O	13	<b>Blue color output.</b> It is a blue color video signal output.
GOUT	O	14	<b>Green color output.</b> It is a green color video signal output.
ROUT	O	15	<b>Red color output.</b> It is a red color video signal output.
VSS	-	16	<b>Digital ground.</b> This ground pin of internal digital circuitry.

## Replacement Parts List

### 1) MultiSync V720 Parts List

B: Asia, C: China, L: LG, S: Samsung, T: Toshiba

	ASSY CODE	PART NO	DESCRIPTION	LOCATION	Q'TY	ALT	REMARK
1	CABINET FRONT ASSY	10100581	CABINET FRONT		1		
2	CABINET FRONT ASSY	11300351	PUSH BUTTON (CONTROL A)		1		
3	CABINET FRONT ASSY	11300781	PUSH BUTTON (SW)		1		
4	CABINET FRONT ASSY	11600121	LENS		1		
5	CABINET FRONT ASSY	13000061	COIL SPRING		1		
6	CRT BOARD A/I	80000561	BEAD 3.5x6x0.8/T	B201	1		
7	CRT BOARD A/I	80000561	BEAD 3.5x6x0.8/T	B208	1		
8	CRT BOARD A/I	GB910358	CERAMIC Z5V(F)/T 0.01u/50V Z	C201	1		
9	CRT BOARD A/I	GB910358	CERAMIC Z5V(F)/T 0.01u/50V Z	C202	1		
10	CRT BOARD A/I	GB910358	CERAMIC Z5V(F)/T 0.01u/50V Z	C203	1		
11	CRT BOARD A/I	GB210458	CERAMIC Y5V/T 0.1u/50V Z	C204	1		
12	CRT BOARD A/I	GB210458	CERAMIC Y5V/T 0.1u/50V Z	C205	1		
13	CRT BOARD A/I	GA310655	ELECT 85oC/T 10u/50V M	C206	1		
14	CRT BOARD A/I	GB910358	CERAMIC Z5V(F)/T 0.01u/50V Z	C207	1		
15	CRT BOARD A/I	GA322725	ELECT 85oC/T 220u/16V M	C209	1		
16	CRT BOARD A/I	GA310655	ELECT 85oC/T 10u/50V M	C210	1		
17	CRT BOARD A/I	GA410575	ELECT NP/T 1u/100V M	C213	1		
18	CRT BOARD A/I	GA210575	ELECT 105oC/T 1u/100V M	C214	1		
19	CRT BOARD A/I	GA310655	ELECT 85oC/T 10u/50V M	C230	1		
20	CRT BOARD A/I	GB910358	CERAMIC Z5V(F)/T 0.01u/50V Z	C231	1		
21	CRT BOARD A/I	GA410575	ELECT NP/T 1u/100V M	C233	1		
22	CRT BOARD A/I	GA210575	ELECT 105oC/T 1u/100V M	C234	1		
23	CRT BOARD A/I	GA310655	ELECT 85oC/T 10u/50V M	C250	1		
24	CRT BOARD A/I	GA410575	ELECT NP/T 1u/100V M	C253	1		
25	CRT BOARD A/I	GA210575	ELECT 105oC/T 1u/100V M	C254	1		
26	CRT BOARD A/I	GB210458	CERAMIC Y5V/T 0.1u/50V Z	C267	1		
27	CRT BOARD A/I	GB910358	CERAMIC Z5V(F)/T 0.01u/50V Z	C270	1		
28	CRT BOARD A/I	GE210252	PLASTIC PEI/T 0.001u/50V J	C271	1		
29	CRT BOARD A/I	GB7471F3	CERAMIC Y5P(B)/T 470P/500V K	C272	1		
30	CRT BOARD A/I	GB7102F3	CERAMIC Y5P(B)/T 1000P/500V K	C275	1		
31	CRT BOARD A/I	GB7102H3	CERAMIC Y5P(B)/T 1000P/1KV K	C276	1		
32	CRT BOARD A/I	GB7102F3	CERAMIC Y5P(B)/T 1000P/500V K	C278	1		
33	CRT BOARD A/I	GB910358	CERAMIC Z5V(F)/T 0.01u/50V Z	C280	1		
34	CRT BOARD A/I	GB910358	CERAMIC Z5V(F)/T 0.01u/50V Z	C281	1		
35	CRT BOARD A/I	GB210458	CERAMIC Y5V/T 0.1u/50V Z	C282	1		
36	CRT BOARD A/I	GB210458	CERAMIC Y5V/T 0.1u/50V Z	C283	1		
37	CRT BOARD A/I	GB210458	CERAMIC Y5V/T 0.1u/50V Z	C284	1		
38	CRT BOARD A/I	GA347625	ELECT 85oC/T 47u/16V M	C285	1		
39	CRT BOARD A/I	GB7102F3	CERAMIC Y5P(B)/T 1000P/500V K	C287	1		
40	CRT BOARD A/I	GA347625	ELECT 85oC/T 47u/16V M	C289	1		
41	CRT BOARD A/I	GB910358	CERAMIC Z5V(F)/T 0.01u/50V Z	C291	1		
42	CRT BOARD A/I	GA310655	ELECT 85oC/T 10u/50V M	C292	1		
43	CRT BOARD A/I	GA310655	ELECT 85oC/T 10u/50V M	C293	1		
44	CRT BOARD A/I	GB910358	CERAMIC Z5V(F)/T 0.01u/50V Z	C294	1		
45	CRT BOARD A/I	GE210352	PLASTIC PEI/T 0.01u/50V J	C295	1		
46	CRT BOARD A/I	GE210352	PLASTIC PEI/T 0.01u/50V J	C296	1		
47	CRT BOARD A/I	GB7102F3	CERAMIC Y5P(B)/T 1000P/500V K	C297	1		
48	CRT BOARD A/I	GB910358	CERAMIC Z5V(F)/T 0.01u/50V Z	C299	1		
49	CRT BOARD A/I	EJAC0017	DIODE/T 1A 1N4936	D201	1		
50	CRT BOARD A/I	EJ044148	DIODE "T" 1N4148	D202	1		
51	CRT BOARD A/I	EJ044148	DIODE "T" 1N4148	D203	1		
52	CRT BOARD A/I	EJ044148	DIODE "T" 1N4148	D204	1		

53	CRT BOARD A/I	EJ044148	DIODE "T" 1N4148	D205	1		
54	CRT BOARD A/I	EJ044148	DIODE "T" 1N4148	D210	1		
55	CRT BOARD A/I	EJ044148	DIODE "T" 1N4148	D211	1		
56	CRT BOARD A/I	80000451	DIODE/T 1/2W 1SS83	D212	1		
57	CRT BOARD A/I	80000051	DIODE/T 1/2W 1SS82	D212	OR		
58	CRT BOARD A/I	80001211	DIODE/T 1/2W BAV21 (PHILIPS)	D212	OR		
59	CRT BOARD A/I	80004711	ROHM DIODE 1SS244	D212	OR		
60	CRT BOARD A/I	80000451	DIODE/T 1/2W 1SS83	D213	1		
61	CRT BOARD A/I	80000051	DIODE/T 1/2W 1SS82	D213	OR		
62	CRT BOARD A/I	80001211	DIODE/T 1/2W BAV21 (PHILIPS)	D213	OR		
63	CRT BOARD A/I	80004711	ROHM DIODE 1SS244	D213	OR		
64	CRT BOARD A/I	80000451	DIODE/T 1/2W 1SS83	D214	1		
65	CRT BOARD A/I	80000051	DIODE/T 1/2W 1SS82	D214	OR		
66	CRT BOARD A/I	80001211	DIODE/T 1/2W BAV21 (PHILIPS)	D214	OR		
67	CRT BOARD A/I	80004711	ROHM DIODE 1SS244	D214	OR		
68	CRT BOARD A/I	EJ044148	DIODE "T" 1N4148	D230	1		
69	CRT BOARD A/I	EJ044148	DIODE "T" 1N4148	D231	1		
70	CRT BOARD A/I	80000451	DIODE/T 1/2W 1SS83	D232	1		
71	CRT BOARD A/I	80000051	DIODE/T 1/2W 1SS82	D232	OR		
72	CRT BOARD A/I	80001211	DIODE/T 1/2W BAV21 (PHILIPS)	D232	OR		
73	CRT BOARD A/I	80004711	ROHM DIODE 1SS244	D232	OR		
74	CRT BOARD A/I	80000451	DIODE/T 1/2W 1SS83	D233	1		
75	CRT BOARD A/I	80000051	DIODE/T 1/2W 1SS82	D233	OR		
76	CRT BOARD A/I	80001211	DIODE/T 1/2W BAV21 (PHILIPS)	D233	OR		
77	CRT BOARD A/I	80004711	ROHM DIODE 1SS244	D233	OR		
78	CRT BOARD A/I	80000451	DIODE/T 1/2W 1SS83	D234	1		
79	CRT BOARD A/I	80000051	DIODE/T 1/2W 1SS82	D234	OR		
80	CRT BOARD A/I	80001211	DIODE/T 1/2W BAV21 (PHILIPS)	D234	OR		
81	CRT BOARD A/I	80004711	ROHM DIODE 1SS244	D234	OR		
82	CRT BOARD A/I	EJ044148	DIODE "T" 1N4148	D250	1		
83	CRT BOARD A/I	EJ044148	DIODE "T" 1N4148	D251	1		
84	CRT BOARD A/I	80000451	DIODE/T 1/2W 1SS83	D252	1		
85	CRT BOARD A/I	80000051	DIODE/T 1/2W 1SS82	D252	OR		
86	CRT BOARD A/I	80001211	DIODE/T 1/2W BAV21 (PHILIPS)	D252	OR		
87	CRT BOARD A/I	80004711	ROHM DIODE 1SS244	D252	OR		
88	CRT BOARD A/I	80000451	DIODE/T 1/2W 1SS83	D253	1		
89	CRT BOARD A/I	80000051	DIODE/T 1/2W 1SS82	D253	OR		
90	CRT BOARD A/I	80001211	DIODE/T 1/2W BAV21 (PHILIPS)	D253	OR		
91	CRT BOARD A/I	80004711	ROHM DIODE 1SS244	D253	OR		
92	CRT BOARD A/I	80000451	DIODE/T 1/2W 1SS83	D254	1		
93	CRT BOARD A/I	80000051	DIODE/T 1/2W 1SS82	D254	OR		
94	CRT BOARD A/I	80001211	DIODE/T 1/2W BAV21 (PHILIPS)	D254	OR		
95	CRT BOARD A/I	80004711	ROHM DIODE 1SS244	D254	OR		
96	CRT BOARD A/I	R0319110	JUMPER WIRE AI/T 7.5mm	J1	1		
97	CRT BOARD A/I	R0319110	JUMPER WIRE AI/T 12.5mm	J10	1		
98	CRT BOARD A/I	R0319110	JUMPER WIRE AI/T 7.5mm	J19	1		
99	CRT BOARD A/I	R0319110	JUMPER WIRE AI/T 10mm	J2	1		
100	CRT BOARD A/I	R0319110	JUMPER WIRE AI/T 7.5mm	J20	1		
101	CRT BOARD A/I	R0319110	JUMPER WIRE AI/T 10mm	J22	1		
102	CRT BOARD A/I	R0319110	JUMPER WIRE AI/T 7.5mm	J24	1		
103	CRT BOARD A/I	R0319110	JUMPER WIRE AI/T 7.5mm	J26	1		
104	CRT BOARD A/I	R0319110	JUMPER WIRE AI/T 15mm	J27	1		
105	CRT BOARD A/I	R0319110	JUMPER WIRE AI/T 7.5mm	J28	1		

106	CRT BOARD A/I	R0319110	JUMPER WIRE AI/T 7.5mm	J29	1		
107	CRT BOARD A/I	R0319110	JUMPER WIRE AI/T 7.5mm	J3	1		
108	CRT BOARD A/I	R0319110	JUMPER WIRE AI/T 7.5mm	J30	1		
109	CRT BOARD A/I	R0319110	JUMPER WIRE AI/T 7.5mm	J32	1		
110	CRT BOARD A/I	R0319110	JUMPER WIRE AI/T 7.5mm	J35	1		
111	CRT BOARD A/I	R0319110	JUMPER WIRE AI/T 7.5mm	J37	1		
112	CRT BOARD A/I	R0319110	JUMPER WIRE AI/T 10mm	J4	1		
113	CRT BOARD A/I	R0319110	JUMPER WIRE AI/T 10mm	J5	1		
114	CRT BOARD A/I	R0319110	JUMPER WIRE AI/T 7.5mm	J6	1		
115	CRT BOARD A/I	R0319110	JUMPER WIRE AI/T 7.5mm	J7	1		
116	CRT BOARD A/I	R0319110	JUMPER WIRE AI/T 7.5mm	J8	1		
117	CRT BOARD A/I	FA040473	CARBON 1/8W(T) 5% 47Kohm	JP1	1		
118	CRT BOARD A/I	HB013828	PACKING COIL /T 0.82uH K(EC24)	L203	1		
119	CRT BOARD A/I	HB013828	PACKING COIL /T 0.82uH K(EC24)	L204	1		
120	CRT BOARD A/I	HB013828	PACKING COIL /T 0.82uH K(EC24)	L205	1		
121	CRT BOARD A/I	HC006002	BEAD 3.5X4.7/T	L206	1		
122	CRT BOARD A/I	EAA12133	TR NPN 2SC1213AC TO-92(T)	Q201	1		
123	CRT BOARD A/I	FA040221	CARBON 1/8W(T) 5% 220ohm	R201	1		
124	CRT BOARD A/I	FA040101	CARBON 1/8W(T) 5% 100ohm	R202	1		
125	CRT BOARD A/I	FA040101	CARBON 1/8W(T) 5% 100ohm	R203	1		
126	CRT BOARD A/I	FA040472	CARBON 1/8W(T) 5% 4.7Kohm	R204	1		
127	CRT BOARD A/I	FA040152	CARBON 1/8W(T) 5% 1.5Kohm	R205	1		
128	CRT BOARD A/I	FA240103	CARBON 1/4W(T) 5% 10Kohm	R206	1		
129	CRT BOARD A/I	FA040101	CARBON 1/8W(T) 5% 100ohm	R208	1		
130	CRT BOARD A/I	FA040101	CARBON 1/8W(T) 5% 100ohm	R209	1		
131	CRT BOARD A/I	FB247509	METAL 1/4W(T) 1% 75ohm	R210	1		
132	CRT BOARD A/I	FA040330	CARBON 1/8W(T) 5% 33ohm	R211	1		
133	CRT BOARD A/I	FA040101	CARBON 1/8W(T) 5% 100ohm	R212	1		
134	CRT BOARD A/I	FA040391	CARBON 1/8W(T) 5% 390ohm	R213	1		
135	CRT BOARD A/I	FA040333	CARBON 1/8W(T) 5% 33Kohm	R219	1		
136	CRT BOARD A/I	FA240151	CARBON 1/4W(T) 5% 150ohm	R220	1		
137	CRT BOARD A/I	FA040111	CARBON 1/8W(T) 5% 110ohm	R221	1		
138	CRT BOARD A/I	FA040224	CARBON 1/8W(T) 5% 220Kohm	R223	1		
139	CRT BOARD A/I	FB247509	METAL 1/4W(T) 1% 75ohm	R230	1		
140	CRT BOARD A/I	FA040330	CARBON 1/8W(T) 5% 33ohm	R231	1		
141	CRT BOARD A/I	FA040101	CARBON 1/8W(T) 5% 100ohm	R232	1		
142	CRT BOARD A/I	FA040391	CARBON 1/8W(T) 5% 390ohm	R233	1		
143	CRT BOARD A/I	FA040333	CARBON 1/8W(T) 5% 33Kohm	R239	1		
144	CRT BOARD A/I	FA240151	CARBON 1/4W(T) 5% 150ohm	R240	1		
145	CRT BOARD A/I	FA040111	CARBON 1/8W(T) 5% 110ohm	R241	1		
146	CRT BOARD A/I	FA040224	CARBON 1/8W(T) 5% 220Kohm	R243	1		
147	CRT BOARD A/I	FB247509	METAL 1/4W(T) 1% 75ohm	R250	1		
148	CRT BOARD A/I	FA040330	CARBON 1/8W(T) 5% 33ohm	R251	1		
149	CRT BOARD A/I	FA040101	CARBON 1/8W(T) 5% 100ohm	R252	1		
150	CRT BOARD A/I	FA040391	CARBON 1/8W(T) 5% 390ohm	R253	1		
151	CRT BOARD A/I	FA040333	CARBON 1/8W(T) 5% 33Kohm	R259	1		
152	CRT BOARD A/I	FA240151	CARBON 1/4W(T) 5% 150ohm	R260	1		
153	CRT BOARD A/I	FA040111	CARBON 1/8W(T) 5% 110ohm	R261	1		
154	CRT BOARD A/I	FA040224	CARBON 1/8W(T) 5% 220Kohm	R263	1		
155	CRT BOARD A/I	FA040221	CARBON 1/8W(T) 5% 220ohm	R270	1		
156	CRT BOARD A/I	FA240223	CARBON 1/4W(T) 5% 22Kohm	R278	1		
157	CRT BOARD A/I	FA240223	CARBON 1/4W(T) 5% 22Kohm	R280	1		
158	CRT BOARD A/I	FA040472	CARBON 1/8W(T) 5% 4.7Kohm	R282	1		

159	CRT BOARD A/I	FA040112	CARBON 1/8W(T) 5% 1.1Kohm	R284	1		
160	CRT BOARD A/I	FA240334	CARBON 1/4W(T) 5% 330Kohm	R286	1		
161	CRT BOARD A/I	FA330101	CARBON 1/2W(T) 5% 100ohm	R287	1		
162	CRT BOARD A/I	FA040103	CARBON 1/8W(T) 5% 10Kohm	R288	1		
163	CRT BOARD A/I	FA040102	CARBON 1/8W(T) 5% 1Kohm	R289	1		
164	CRT BOARD A/I	FA240223	CARBON 1/4W(T) 5% 22Kohm	R290	1		
165	CRT BOARD A/I	FA040472	CARBON 1/8W(T) 5% 4.7Kohm	R291	1		
166	CRT BOARD A/I	FA240101	CARBON 1/4W(T) 5% 100ohm	R292	1		
167	CRT BOARD A/I	FA040103	CARBON 1/8W(T) 5% 10Kohm	R293	1		
168	CRT BOARD A/I	FA040562	CARBON 1/8W(T) 5% 5.6Kohm	R294	1		
169	CRT BOARD A/I	FA040562	CARBON 1/8W(T) 5% 5.6Kohm	R295	1		
170	CRT BOARD A/I	FA040105	CARBON 1/8W(T) 5% 1Mohm	R296	1		
171	CRT BOARD A/I	FA040473	CARBON 1/8W(T) 5% 47Kohm	VR201	1		
172	CRT BOARD A/I	FA040473	CARBON 1/8W(T) 5% 47Kohm	VR202	1		
173	CRT BOARD A/I	72000281	PN9501 CRT BOARD(29D NECK)		1		
174	CRT BOARD INSERT	GB9332H8	CERAMIC Z5V(F)/T 3300P/1KV Z	C277	1		
175	CRT BOARD INSERT	GAB22675	ELECT 105oC/T 22u/100V M	C288	1		
176	CRT BOARD INSERT	R0224070	SINGLE PIN 1P L=14mm 2.36mm	CRT GND	1		
177	CRT BOARD INSERT	80001751	17" 29D NECK CRT SOCKET	CRT SOCKET 29D	1	L,S	
178	CRT BOARD INSERT	80005011	CRT SOCKET 29D (PIN 12 GND)	CRT SOCKET 30D	1	T	
179	CRT BOARD INSERT	14000041	SCREW (P-#2CBRITS*3*8*15BF)	FOR U203	1		
180	CRT BOARD INSERT	HB013100	PACKING COIL /T 10uH K(EC24)	J23	1		
181	CRT BOARD INSERT	HB000008	CHOKE COIL 100uH 8X10	L201	1		
182	CRT BOARD INSERT	HB000008	CHOKE COIL 100uH 8X10	L202	1		
183	CRT BOARD INSERT	FB910229	FUSIBLE MF RES 1/4W 2.2ohm J	R297	1		
184	CRT BOARD INSERT	R0224129	BASE PIN 6P+HOUSING P=2.5mm	S201	1		
185	CRT BOARD INSERT	R0224127	XH-BASE PIN 4P	S202	1		
186	CRT BOARD INSERT	R0224129	BASE PIN 6P+HOUSING P=2.5mm	S204	1		
187	CRT BOARD INSERT	R0224130	BASE PIN 7P+HOUSING P=2.5mm	S205	1		
188	CRT BOARD INSERT	80000631	IC LM1281	U201	1		
189	CRT BOARD INSERT	80003661	N.S VIDEO DRIVE IC LM2438	U203	1		
190	CRT BOARD INSERT	80001941	OSD IC MTV016N	U204	1		
191	CRT BOARD INSERT	FF300203	VR CARBON 6mm 20K/B	VR210	1		
192	CRT BOARD INSERT	FF300203	VR CARBON 6mm 20K/B	VR230	1		
193	CRT BOARD INSERT	FF300203	VR CARBON 6mm 20K/B	VR250	1		
194	CRT BOARD INSERT	12600112	HEAT SINK (VIDEO)		1		
195	MAIN BOARD A/I	HC006002	BEAD 3.5X4.7/T	B101	1		
196	MAIN BOARD A/I	80000561	BEAD 3.5x6x0.8/T	B103	1		
197	MAIN BOARD A/I	R0319110	JUMPER WIRE AI/T 10mm	B104	1		
198	MAIN BOARD A/I	HC006002	BEAD 3.5X4.7/T	B105	1		
199	MAIN BOARD A/I	HC006002	BEAD 3.5X4.7/T	B105	1		
200	MAIN BOARD A/I	HC006002	BEAD 3.5X4.7/T	B106	1		
201	MAIN BOARD A/I	R0319110	JUMPER WIRE AI/T 10mm	B107	1		
202	MAIN BOARD A/I	80000561	BEAD 3.5x6x0.8/T	B108	1		
203	MAIN BOARD A/I	80000561	BEAD 3.5x6x0.8/T	B109	1		
204	MAIN BOARD A/I	HC006002	BEAD 3.5X4.7/T	B301	1		
205	MAIN BOARD A/I	HC006002	BEAD 3.5X4.7/T	B302	1		
206	MAIN BOARD A/I	HC006002	BEAD 3.5X4.7/T	B303	1		
207	MAIN BOARD A/I	R0319110	JUMPER WIRE AI/T 5mm	B31A	1		
208	MAIN BOARD A/I	HC006002	BEAD 3.5X4.7/T	B701	1		
209	MAIN BOARD A/I	GB8103F5	CERAMIC Z5U(E)/T 0.01u/500V M	C106	1		
210	MAIN BOARD A/I	GB8103F5	CERAMIC Z5U(E)/T 0.01u/500V M	C107	1		
211	MAIN BOARD A/I	GA347625	ELECT 85oC/T 47u/16V M	C108	1		

212	MAIN BOARD A/I	GA322645	ELECT 85oC/T 22u/35V M	C109	1		
213	MAIN BOARD A/I	GB747153	CERAMIC Y5P(B)/T 470P/50V K	C110	1		
214	MAIN BOARD A/I	GE210352	PLASTIC PEI/T 0.01u/50V J	C111	1		
215	MAIN BOARD A/I	GB910358	CERAMIC Z5V(F)/T 0.01u/50V Z	C112	1		
216	MAIN BOARD A/I	GA310655	ELECT 85oC/T 10u/50V M	C113	1		
217	MAIN BOARD A/I	GF210462	MEF CAP BOX 0.1u/63V J	C114	1		
218	MAIN BOARD A/I	GF210452	MEF CAP BOX 0.1u/50V J	C114	OR		
219	MAIN BOARD A/I	GF233262	MEF CAP BOX 0.0033u/63V J	C115	1		
220	MAIN BOARD A/I	GF233252	MEF CAP BOX 0.0033u/50V J	C115	OR		
221	MAIN BOARD A/I	GA310655	ELECT 85oC/T 10u/50V M	C116	1		
222	MAIN BOARD A/I	GAH22675	ELECT 105oC/T 22u/100V M TK	C119	1		
223	MAIN BOARD A/I	GAJ22675	ELECT 105oC/T 22u/100V M PF	C119	OR		
224	MAIN BOARD A/I	GAH10825	ELECT 105oC/T 1000u/16V M TK	C121	1		
225	MAIN BOARD A/I	GAJ10825	ELECT 105oC/T 1000u/16V M PF	C121	OR		
226	MAIN BOARD A/I	GE222352	PLASTIC PEI/T 0.022u/50V J	C123	1		
227	MAIN BOARD A/I	GB7331H3	CERAMIC Y5P(B)/T 330P/1KV K	C124	1		
228	MAIN BOARD A/I	GB7101H3	CERAMIC Y5P(B)/T 100P/1KV K	C127	1		
229	MAIN BOARD A/I	GA347625	ELECT 85oC/T 47u/16V M	C130	1		
230	MAIN BOARD A/I	GF210462	MEF CAP BOX 0.1u/63V J	C131	1		
231	MAIN BOARD A/I	GF210452	MEF CAP BOX 0.1u/50V J	C131	OR		
232	MAIN BOARD A/I	GE233352	PLASTIC PEI/T 0.033u/50V J	C132	1		
233	MAIN BOARD A/I	GF233262	MEF CAP BOX 0.0033u/63V J	C133	1		
234	MAIN BOARD A/I	GF233252	MEF CAP BOX 0.0033u/50V J	C133	OR		
235	MAIN BOARD A/I	GB747153	CERAMIC Y5P(B)/T 470P/50V K	C134	1		
236	MAIN BOARD A/I	GB747153	CERAMIC Y5P(B)/T 470P/50V K	C135	1		
237	MAIN BOARD A/I	GA347725	ELECT 85oC/T 470u/16V M	C136	1		
238	MAIN BOARD A/I	GA347625	ELECT 85oC/T 47u/16V M	C137	1		
239	MAIN BOARD A/I	GAH47725	ELECT 105oC/T 470u/16V M TK	C139	1		
240	MAIN BOARD A/I	GAJ47725	ELECT 105oC/T 470u/16V M PF	C139	OR		
241	MAIN BOARD A/I	GE210352	PLASTIC PEI/T 0.01u/50V J	C140	1		
242	MAIN BOARD A/I	GA310725	ELECT 85oC/T 100u/16V M	C141	1		
243	MAIN BOARD A/I	GE210352	PLASTIC PEI/T 0.01u/50V J	C142	1		
244	MAIN BOARD A/I	GA310555	ELECT 85oC/T 1u/50V M	C145	1		
245	MAIN BOARD A/I	GB910358	CERAMIC Z5V(F)/T 0.01u/50V Z	C149	1		
246	MAIN BOARD A/I	GA310655	ELECT 85oC/T 10u/50V M	C150	1		
247	MAIN BOARD A/I	GA347625	ELECT 85oC/T 47u/16V M	C151	1		
248	MAIN BOARD A/I	GB7471F3	CERAMIC Y5P(B)/T 470P/500V K	C152	1		
249	MAIN BOARD A/I	GA247555	ELECT 105oC/T 4.7u/50V M	C156	1		
250	MAIN BOARD A/I	GE210352	PLASTIC PEI/T 0.01u/50V J	C162	1		
251	MAIN BOARD A/I	GA347555	ELECT 85oC/T 4.7u/50V M	C164	1		
252	MAIN BOARD A/I	GB910358	CERAMIC Z5V(F)/T 0.01u/50V Z	C301	1		
253	MAIN BOARD A/I	GF210462	MEF CAP BOX 0.1u/63V J	C302	1		
254	MAIN BOARD A/I	GF210452	MEF CAP BOX 0.1u/50V J	C302	OR		
255	MAIN BOARD A/I	GB910358	CERAMIC Z5V(F)/T 0.01u/50V Z	C304	1		
256	MAIN BOARD A/I	GA347625	ELECT 85oC/T 47u/16V M	C305	1		
257	MAIN BOARD A/I	GA310655	ELECT 85oC/T 10u/50V M	C306	1		
258	MAIN BOARD A/I	GE210352	PLASTIC PEI/T 0.01u/50V J	C307	1		
259	MAIN BOARD A/I	GA310655	ELECT 85oC/T 10u/50V M	C308	1		
260	MAIN BOARD A/I	GA347555	ELECT 85oC/T 4.7u/50V M	C309	1		
261	MAIN BOARD A/I	GA347555	ELECT 85oC/T 4.7u/50V M	C312	1		
262	MAIN BOARD A/I	GA347655	ELECT 85oC/T 47u/50V M	C313	1		
263	MAIN BOARD A/I	GF210452	MEF CAP BOX 0.1u/50V J	C314	1		
264	MAIN BOARD A/I	GF210462	MEF CAP BOX 0.1u/63V J	C314	OR		



265	MAIN BOARD A/I	GF210252	MEF CAP BOX 0.001u/50V J	C315	1		
266	MAIN BOARD A/I	GF210262	MEF CAP BOX 0.001u/63V J	C315	OR		
267	MAIN BOARD A/I	GF247262	MEF CAP BOX 0.0047u/63V J	C316	1		
268	MAIN BOARD A/I	GF247252	MEF CAP BOX 0.0047u/50V J	C316	OR		
269	MAIN BOARD A/I	GA347455	ELECT 85oC/T 0.47u/50V M	C317	1		
270	MAIN BOARD A/I	GA322725	ELECT 85oC/T 220u/16V M	C320	1		
271	MAIN BOARD A/I	R0319110	JUMPER WIRE AI/T 5mm	C322	1	T	
272	MAIN BOARD A/I	GB910358	CERAMIC Z5V(F)/T 0.01u/50V Z	C322	1	L,S	
273	MAIN BOARD A/I	GB7102F3	CERAMIC Y5P(B)/T 1000P/500V K	C323	1	L,S	
274	MAIN BOARD A/I	GF222462	MEF CAP BOX 0.22u/63V J	C326	1		
275	MAIN BOARD A/I	GF222452	MEF CAP BOX 0.22u/50V J	C326	OR		
276	MAIN BOARD A/I	GA310555	ELECT 85oC/T 1u/50V M	C328	1		
277	MAIN BOARD A/I	GA347725	ELECT 85oC/T 470u/16V M	C330	1		
278	MAIN BOARD A/I	GB8103F5	CERAMIC Z5U(E)/T 0.01u/500V M	C331	1		
279	MAIN BOARD A/I	GB7102H3	CERAMIC Y5P(B)/T 1000P/1KV K	C334	1		
280	MAIN BOARD A/I	GA347625	ELECT 85oC/T 47u/16V M	C335	1		
281	MAIN BOARD A/I	GA310555	ELECT 85oC/T 1u/50V M	C336	1		
282	MAIN BOARD A/I	GA310655	ELECT 85oC/T 10u/50V M	C337	1		
283	MAIN BOARD A/I	GA310655	ELECT 85oC/T 10u/50V M	C338	1		
284	MAIN BOARD A/I	GA410585	ELECT NP/T 1u/250V M	C339	1		
285	MAIN BOARD A/I	GA310555	ELECT 85oC/T 1u/50V M	C340	1		
286	MAIN BOARD A/I	GB7471F3	CERAMIC Y5P(B)/T 470P/500V K	C341	1		
287	MAIN BOARD A/I	GF210462	MEF CAP BOX 0.1u/63V J	C343	1	T	
288	MAIN BOARD A/I	GE233352	PLASTIC PEI/T 0.033u/50V J	C343	1	L,S	
289	MAIN BOARD A/I	GF210452	MEF CAP BOX 0.1u/50V J	C343	OR	T	
290	MAIN BOARD A/I	GA347585	ELECT 85oC/T 4.7u/250V M	C344	1		
291	MAIN BOARD A/I	GE222352	PLASTIC PEI/T 0.022u/50V J	C348	1		
292	MAIN BOARD A/I	GE233352	PLASTIC PEI/T 0.033u/50V J	C350	1		
293	MAIN BOARD A/I	GA310555	ELECT 85oC/T 1u/50V M	C352	1		
294	MAIN BOARD A/I	GB633152	CERAMIC SL/T 330P/50V J	C353	1		
295	MAIN BOARD A/I	GE222352	PLASTIC PEI/T 0.022u/50V J	C354	1		
296	MAIN BOARD A/I	GB7102H3	CERAMIC Y5P(B)/T 1000P/1KV K	C357	1	L,S	
297	MAIN BOARD A/I	GE210252	PLASTIC PEI/T 0.001u/50V J	C401	1		
298	MAIN BOARD A/I	GA310655	ELECT 85oC/T 10u/50V M	C402	1		
299	MAIN BOARD A/I	GF222452	MEF CAP BOX 0.22u/50V J	C403	1		
300	MAIN BOARD A/I	GF222462	MEF CAP BOX 0.22u/63V J	C403	OR		
301	MAIN BOARD A/I	GAH47725	ELECT 105oC/T 470u/16V M TK	C404	1		
302	MAIN BOARD A/I	GAJ47725	ELECT 105oC/T 470u/16V M PF	C404	OR		
303	MAIN BOARD A/I	GE222252	PLASTIC PEI/T 0.0022u/50V J	C405	1		
304	MAIN BOARD A/I	GA310655	ELECT 85oC/T 10u/50V M	C406	1		
305	MAIN BOARD A/I	GB210458	CERAMIC Y5V/T 0.1u/50V Z	C407	1		
306	MAIN BOARD A/I	GAH10825	ELECT 105oC/T 1000u/16V M TK	C408	1		
307	MAIN BOARD A/I	GAJ10825	ELECT 105oC/T 1000u/16V M PF	C408	OR		
308	MAIN BOARD A/I	GB910358	CERAMIC Z5V(F)/T 0.01u/50V Z	C409	1		
309	MAIN BOARD A/I	GA310745	ELECT 85oC/T 100u/35V M	C410	1		
310	MAIN BOARD A/I	GA310655	ELECT 85oC/T 10u/50V M	C416	1		
311	MAIN BOARD A/I	GE233252	PLASTIC PEI/T 0.0033u/50V J	C417	1		
312	MAIN BOARD A/I	GA310725	ELECT 85oC/T 100u/16V M	C418	1		
313	MAIN BOARD A/I	GA310655	ELECT 85oC/T 10u/50V M	C419	1		
314	MAIN BOARD A/I	GB910358	CERAMIC Z5V(F)/T 0.01u/50V Z	C420	1		
315	MAIN BOARD A/I	GA310655	ELECT 85oC/T 10u/50V M	C423	1		
316	MAIN BOARD A/I	GA322725	ELECT 85oC/T 220u/16V M	C424	1		
317	MAIN BOARD A/I	GA347485	ELECT 85oC/T 0.47u/250V M	C428	1		

318	MAIN BOARD A/I	GA422625	ELECT NP/T 22u/16V M	C431	1		
319	MAIN BOARD A/I	GA310655	ELECT 85oC/T 10u/50V M	C433	1		
320	MAIN BOARD A/I	GA310655	ELECT 85oC/T 10u/50V M	C435	1		
321	MAIN BOARD A/I	GA310655	ELECT 85oC/T 10u/50V M	C437	1		
322	MAIN BOARD A/I	GA310655	ELECT 85oC/T 10u/50V M	C438	1		
323	MAIN BOARD A/I	GA310555	ELECT 85oC/T 1u/50V M	C440	1		
324	MAIN BOARD A/I	GE247252	PLASTIC PEI/T 0.0047u/50V J	C442	1		
325	MAIN BOARD A/I	GA347555	ELECT 85oC/T 4.7u/50V M	C446	1		
326	MAIN BOARD A/I	GA347455	ELECT 85oC/T 0.47u/50V M	C447	1		
327	MAIN BOARD A/I	GF210462	MEF CAP BOX 0.1u/63V J	C448	1		
328	MAIN BOARD A/I	GF210452	MEF CAP BOX 0.1u/50V J	C448	OR		
329	MAIN BOARD A/I	GA347555	ELECT 85oC/T 4.7u/50V M	C450	1		
330	MAIN BOARD A/I	GE268252	PLASTIC PEI/T 0.0068u/50V J	C601	1		
331	MAIN BOARD A/I	GE210352	PLASTIC PEI/T 0.01u/50V J	C603	1		
332	MAIN BOARD A/I	GA310655	ELECT 85oC/T 10u/50V M	C604	1		
333	MAIN BOARD A/I	GB710253	CERAMIC Y5P(B)/T 1000P/50V K	C605	1		
334	MAIN BOARD A/I	GA310555	ELECT 85oC/T 1u/50V M	C701	1		
335	MAIN BOARD A/I	GB210458	CERAMIC Y5V/T 0.1u/50V Z	C702	1		
336	MAIN BOARD A/I	GA310725	ELECT 85oC/T 100u/16V M	C703	1		
337	MAIN BOARD A/I	GA322555	ELECT 85oC/T 2.2u/50V M	C704	1		
338	MAIN BOARD A/I	GB633052	CERAMIC SL/T 33P/50V J	C705	1		
339	MAIN BOARD A/I	GB633052	CERAMIC SL/T 33P/50V J	C706	1		
340	MAIN BOARD A/I	GB610152	CERAMIC SL/T 100P/50V J	C707	1		
341	MAIN BOARD A/I	GB610152	CERAMIC SL/T 100P/50V J	C708	1		
342	MAIN BOARD A/I	GB910358	CERAMIC Z5V(F)/T 0.01u/50V Z	C724	1		
343	MAIN BOARD A/I	GA347625	ELECT 85oC/T 47u/16V M	C725	1		
344	MAIN BOARD A/I	GA310655	ELECT 85oC/T 10u/50V M	C726	1		
345	MAIN BOARD A/I	GA310655	ELECT 85oC/T 10u/50V M	C727	1		
346	MAIN BOARD A/I	GA310655	ELECT 85oC/T 10u/50V M	C728	1		
347	MAIN BOARD A/I	EJA20003	DIODE/T 1A BA159	D105	1		
348	MAIN BOARD A/I	EJAC0017	DIODE/T 1A 1N4936	D106	1		
349	MAIN BOARD A/I	EJ044148	DIODE "T" 1N4148	D107	1		
350	MAIN BOARD A/I	EJAC0017	DIODE/T 1A 1N4936	D108	1		
351	MAIN BOARD A/I	EJ044148	DIODE "T" 1N4148	D109	1		
352	MAIN BOARD A/I	EJ044148	DIODE "T" 1N4148	D115	1		
353	MAIN BOARD A/I	EJA20003	DIODE/T 1A BA159	D116	1		
354	MAIN BOARD A/I	EJ044148	DIODE "T" 1N4148	D117	1		
355	MAIN BOARD A/I	EJ044148	DIODE "T" 1N4148	D119	1		
356	MAIN BOARD A/I	EJ044148	DIODE "T" 1N4148	D120	1		
357	MAIN BOARD A/I	EJAC0018	DIODE/T 1A 1N4937	D124	1		
358	MAIN BOARD A/I	EJ044148	DIODE "T" 1N4148	D125	1		
359	MAIN BOARD A/I	EJ044148	DIODE "T" 1N4148	D126	1		
360	MAIN BOARD A/I	EJ044148	DIODE "T" 1N4148	D127	1		
361	MAIN BOARD A/I	EJ044148	DIODE "T" 1N4148	D128	1		
362	MAIN BOARD A/I	EJ044148	DIODE "T" 1N4148	D129	1		
363	MAIN BOARD A/I	EJAC0017	DIODE/T 1A 1N4936	D130	1		
364	MAIN BOARD A/I	EJ044148	DIODE "T" 1N4148	D133	1		
365	MAIN BOARD A/I	EJA05819	DIODE STKY/T 1A/40V 1N5819	D134	1		
366	MAIN BOARD A/I	EJAC0018	DIODE/T 1A 1N4937	D301	1		
367	MAIN BOARD A/I	EJ044148	DIODE "T" 1N4148	D302	1		
368	MAIN BOARD A/I	EJAC0018	DIODE/T 1A 1N4937	D303	1		
369	MAIN BOARD A/I	EJ044148	DIODE "T" 1N4148	D304	1		
370	MAIN BOARD A/I	EJA05819	DIODE STKY/T 1A/40V 1N5819	D305	1		

371	MAIN BOARD A/I	EJ044148	DIODE "T" 1N4148	D306	1		
372	MAIN BOARD A/I	EJ044148	DIODE "T" 1N4148	D310	1		
373	MAIN BOARD A/I	EJ044148	DIODE "T" 1N4148	D311	1		
374	MAIN BOARD A/I	EJAC0018	DIODE/T 1A 1N4937	D312	1		
375	MAIN BOARD A/I	EJ044148	DIODE "T" 1N4148	D313	1		
376	MAIN BOARD A/I	EJ044148	DIODE "T" 1N4148	D314	1		
377	MAIN BOARD A/I	EJ044148	DIODE "T" 1N4148	D315	1		
378	MAIN BOARD A/I	EJAC0018	DIODE/T 1A 1N4937	D318	1		
379	MAIN BOARD A/I	EJ044148	DIODE "T" 1N4148	D320	1		
380	MAIN BOARD A/I	EJAC0018	DIODE/T 1A 1N4937	D321	1		
381	MAIN BOARD A/I	EJAC0018	DIODE/T 1A 1N4937	D322	1		
382	MAIN BOARD A/I	EJ044148	DIODE "T" 1N4148	D323	1		
383	MAIN BOARD A/I	EJAC0018	DIODE/T 1A 1N4937	D324	1		
384	MAIN BOARD A/I	EJ044148	DIODE "T" 1N4148	D325	1		
385	MAIN BOARD A/I	EJA20003	DIODE/T 1A BA159	D326	1		
386	MAIN BOARD A/I	EJAC0018	DIODE/T 1A 1N4937	D328	1		
387	MAIN BOARD A/I	EJAC0018	DIODE/T 1A 1N4937	D329	1		
388	MAIN BOARD A/I	EJAC0018	DIODE/T 1A 1N4937	D330	1		
389	MAIN BOARD A/I	EJ044148	DIODE "T" 1N4148	D331	1		
390	MAIN BOARD A/I	EJ044148	DIODE "T" 1N4148	D401	1		
391	MAIN BOARD A/I	EJ044148	DIODE "T" 1N4148	D402	1		
392	MAIN BOARD A/I	EJAC0018	DIODE/T 1A 1N4937	D403	1		
393	MAIN BOARD A/I	EJ044148	DIODE "T" 1N4148	D601	1		
394	MAIN BOARD A/I	EJ044148	DIODE "T" 1N4148	D602	1		
395	MAIN BOARD A/I	EJ044148	DIODE "T" 1N4148	D604	1		
396	MAIN BOARD A/I	EJ044148	DIODE "T" 1N4148	D605	1		
397	MAIN BOARD A/I	EJ044148	DIODE "T" 1N4148	D60A	1		
398	MAIN BOARD A/I	EJA05819	DIODE STKY/T 1A/40V 1N5819	D702	1		
399	MAIN BOARD A/I	EJ044148	DIODE "T" 1N4148	D704	1		
400	MAIN BOARD A/I	R0319110	JUMPER WIRE AI/T 17.5mm	J1	1		
401	MAIN BOARD A/I	R0319110	JUMPER WIRE AI/T 10mm	J10	1		
402	MAIN BOARD A/I	R0319110	JUMPER WIRE AI/T 10mm	J100	1		
403	MAIN BOARD A/I	R0319110	JUMPER WIRE AI/T 20mm	J101	1		
404	MAIN BOARD A/I	R0319110	JUMPER WIRE AI/T 10mm	J102	1		
405	MAIN BOARD A/I	R0319110	JUMPER WIRE AI/T 20mm	J103	1		
406	MAIN BOARD A/I	R0319110	JUMPER WIRE AI/T 7.5mm	J105	1		
407	MAIN BOARD A/I	R0319110	JUMPER WIRE AI/T 15mm	J106	1		
408	MAIN BOARD A/I	R0319110	JUMPER WIRE AI/T 15mm	J107	1		
409	MAIN BOARD A/I	R0319110	JUMPER WIRE AI/T 12.5mm	J108	1		
410	MAIN BOARD A/I	R0319110	JUMPER WIRE AI/T 17.5mm	J109	1		
411	MAIN BOARD A/I	R0319110	JUMPER WIRE AI/T 12.5mm	J11	1		
412	MAIN BOARD A/I	R0319110	JUMPER WIRE AI/T 17.5mm	J110	1		
413	MAIN BOARD A/I	R0319110	JUMPER WIRE AI/T 15mm	J111	1		
414	MAIN BOARD A/I	R0319110	JUMPER WIRE AI/T 7.5mm	J112	1		
415	MAIN BOARD A/I	R0319110	JUMPER WIRE AI/T 15mm	J113	1		
416	MAIN BOARD A/I	R0319110	JUMPER WIRE AI/T 12.5mm	J114	1		
417	MAIN BOARD A/I	R0319110	JUMPER WIRE AI/T 10mm	J115	1		
418	MAIN BOARD A/I	R0319110	JUMPER WIRE AI/T 7.5mm	J116	1		
419	MAIN BOARD A/I	R0319110	JUMPER WIRE AI/T 15mm	J117	1		
420	MAIN BOARD A/I	R0319110	JUMPER WIRE AI/T 10mm	J118	1		
421	MAIN BOARD A/I	R0319110	JUMPER WIRE AI/T 10mm	J119	1		
422	MAIN BOARD A/I	R0319110	JUMPER WIRE AI/T 15mm	J12	1		
423	MAIN BOARD A/I	R0319110	JUMPER WIRE AI/T 12.5mm	J120	1		

424	MAIN BOARD A/I	R0319110	JUMPER WIRE AI/T 12.5mm	J121	1		
425	MAIN BOARD A/I	R0319110	JUMPER WIRE AI/T 12.5mm	J122	1		
426	MAIN BOARD A/I	R0319110	JUMPER WIRE AI/T 17.5mm	J123	1		
427	MAIN BOARD A/I	R0319110	JUMPER WIRE AI/T 10mm	J124	1		
428	MAIN BOARD A/I	R0319110	JUMPER WIRE AI/T 10mm	J125	1		
429	MAIN BOARD A/I	R0319110	JUMPER WIRE AI/T 10mm	J126	1		
430	MAIN BOARD A/I	R0319110	JUMPER WIRE AI/T 12.5mm	J127	1		
431	MAIN BOARD A/I	R0319110	JUMPER WIRE AI/T 12.5mm	J128	1		
432	MAIN BOARD A/I	R0319110	JUMPER WIRE AI/T 12.5mm	J129	1		
433	MAIN BOARD A/I	R0319110	JUMPER WIRE AI/T 10mm	J13	1		
434	MAIN BOARD A/I	R0319110	JUMPER WIRE AI/T 12.5mm	J130	1		
435	MAIN BOARD A/I	R0319110	JUMPER WIRE AI/T 20mm	J131	1		
436	MAIN BOARD A/I	R0319110	JUMPER WIRE AI/T 15mm	J132	1		
437	MAIN BOARD A/I	R0319110	JUMPER WIRE AI/T 15mm	J133	1		
438	MAIN BOARD A/I	R0319110	JUMPER WIRE AI/T 15mm	J134	1		
439	MAIN BOARD A/I	R0319110	JUMPER WIRE AI/T 17.5mm	J135	1		
440	MAIN BOARD A/I	R0319110	JUMPER WIRE AI/T 17.5mm	J136	1		
441	MAIN BOARD A/I	R0319110	JUMPER WIRE AI/T 17.5mm	J137	1		
442	MAIN BOARD A/I	R0319110	JUMPER WIRE AI/T 17.5mm	J138	1		
443	MAIN BOARD A/I	R0319110	JUMPER WIRE AI/T 7.5mm	J139	1		
444	MAIN BOARD A/I	R0319110	JUMPER WIRE AI/T 12.5mm	J14	1		
445	MAIN BOARD A/I	R0319110	JUMPER WIRE AI/T 12.5mm	J15	1		
446	MAIN BOARD A/I	R0319110	JUMPER WIRE AI/T 10mm	J16	1		
447	MAIN BOARD A/I	R0319110	JUMPER WIRE AI/T 10mm	J17	1		
448	MAIN BOARD A/I	R0319110	JUMPER WIRE AI/T 10mm	J19	1		
449	MAIN BOARD A/I	R0319110	JUMPER WIRE AI/T 12.5mm	J2	1		
450	MAIN BOARD A/I	R0319110	JUMPER WIRE AI/T 10mm	J20	1		
451	MAIN BOARD A/I	R0319110	JUMPER WIRE AI/T 7.5mm	J21	1		
452	MAIN BOARD A/I	R0319110	JUMPER WIRE AI/T 17.5mm	J22	1		
453	MAIN BOARD A/I	R0319110	JUMPER WIRE AI/T 10mm	J23	1		
454	MAIN BOARD A/I	R0319110	JUMPER WIRE AI/T 10mm	J24	1		
455	MAIN BOARD A/I	R0319110	JUMPER WIRE AI/T 7.5mm	J26	1		
456	MAIN BOARD A/I	R0319110	JUMPER WIRE AI/T 7.5mm	J27	1		
457	MAIN BOARD A/I	R0319110	JUMPER WIRE AI/T 10mm	J28	1		
458	MAIN BOARD A/I	R0319110	JUMPER WIRE AI/T 7.5mm	J29	1		
459	MAIN BOARD A/I	R0319110	JUMPER WIRE AI/T 12.5mm	J3	1		
460	MAIN BOARD A/I	R0319110	JUMPER WIRE AI/T 17.5mm	J30	1		
461	MAIN BOARD A/I	R0319110	JUMPER WIRE AI/T 10mm	J31	1		
462	MAIN BOARD A/I	R0319110	JUMPER WIRE AI/T 20mm	J33	1		
463	MAIN BOARD A/I	R0319110	JUMPER WIRE AI/T 10mm	J34	1		
464	MAIN BOARD A/I	R0319110	JUMPER WIRE AI/T 10mm	J35	1		
465	MAIN BOARD A/I	R0319110	JUMPER WIRE AI/T 15mm	J36	1		
466	MAIN BOARD A/I	R0319110	JUMPER WIRE AI/T 7.5mm	J37	1		
467	MAIN BOARD A/I	R0319110	JUMPER WIRE AI/T 7.5mm	J38	1		
468	MAIN BOARD A/I	R0319110	JUMPER WIRE AI/T 10mm	J39	1		
469	MAIN BOARD A/I	R0319110	JUMPER WIRE AI/T 10mm	J4	1		
470	MAIN BOARD A/I	R0319110	JUMPER WIRE AI/T 10mm	J40	1		
471	MAIN BOARD A/I	HB003101	PACKING COIL /T 100uH	J41	1		
472	MAIN BOARD A/I	R0319110	JUMPER WIRE AI/T 10mm	J42	1		
473	MAIN BOARD A/I	R0319110	JUMPER WIRE AI/T 12.5mm	J43	1		
474	MAIN BOARD A/I	R0319110	JUMPER WIRE AI/T 20mm	J44	1		
475	MAIN BOARD A/I	R0319110	JUMPER WIRE AI/T 7.5mm	J45	1		
476	MAIN BOARD A/I	R0319110	JUMPER WIRE AI/T 10mm	J46	1		

477	MAIN BOARD A/I	R0319110	JUMPER WIRE AI/T 10mm	J47	1		
478	MAIN BOARD A/I	R0319110	JUMPER WIRE AI/T 10mm	J48	1		
479	MAIN BOARD A/I	R0319110	JUMPER WIRE AI/T 12.5mm	J49	1		
480	MAIN BOARD A/I	R0319110	JUMPER WIRE AI/T 10mm	J5	1		
481	MAIN BOARD A/I	R0319110	JUMPER WIRE AI/T 7.5mm	J51	1		
482	MAIN BOARD A/I	R0319110	JUMPER WIRE AI/T 12.5mm	J52	1		
483	MAIN BOARD A/I	R0319110	JUMPER WIRE AI/T 12.5mm	J53	1		
484	MAIN BOARD A/I	R0319110	JUMPER WIRE AI/T 12.5mm	J54	1		
485	MAIN BOARD A/I	R0319110	JUMPER WIRE AI/T 12.5mm	J55	1		
486	MAIN BOARD A/I	R0319110	JUMPER WIRE AI/T 17.5mm	J56	1		
487	MAIN BOARD A/I	R0319110	JUMPER WIRE AI/T 17.5mm	J57	1		
488	MAIN BOARD A/I	R0319110	JUMPER WIRE AI/T 10mm	J58	1		
489	MAIN BOARD A/I	R0319110	JUMPER WIRE AI/T 12.5mm	J59	1		
490	MAIN BOARD A/I	R0319110	JUMPER WIRE AI/T 10mm	J6	1		
491	MAIN BOARD A/I	R0319110	JUMPER WIRE AI/T 12.5mm	J61	1		
492	MAIN BOARD A/I	R0319110	JUMPER WIRE AI/T 7.5mm	J62	1		
493	MAIN BOARD A/I	R0319110	JUMPER WIRE AI/T 20mm	J64	1		
494	MAIN BOARD A/I	R0319110	JUMPER WIRE AI/T 10mm	J66	1		
495	MAIN BOARD A/I	R0319110	JUMPER WIRE AI/T 10mm	J67	1		
496	MAIN BOARD A/I	R0319110	JUMPER WIRE AI/T 17.5mm	J68	1		
497	MAIN BOARD A/I	R0319110	JUMPER WIRE AI/T 10mm	J69	1		
498	MAIN BOARD A/I	R0319110	JUMPER WIRE AI/T 7.5mm	J7	1		
499	MAIN BOARD A/I	R0319110	JUMPER WIRE AI/T 17.5mm	J70	1		
500	MAIN BOARD A/I	R0319110	JUMPER WIRE AI/T 7.5mm	J71	1		
501	MAIN BOARD A/I	R0319110	JUMPER WIRE AI/T 7.5mm	J72	1		
502	MAIN BOARD A/I	R0319110	JUMPER WIRE AI/T 10mm	J73	1		
503	MAIN BOARD A/I	R0319110	JUMPER WIRE AI/T 12.5mm	J74	1		
504	MAIN BOARD A/I	R0319110	JUMPER WIRE AI/T 17.5mm	J75	1		
505	MAIN BOARD A/I	R0319110	JUMPER WIRE AI/T 10mm	J76	1		
506	MAIN BOARD A/I	R0319110	JUMPER WIRE AI/T 12.5mm	J77	1		
507	MAIN BOARD A/I	R0319110	JUMPER WIRE AI/T 12.5mm	J78	1		
508	MAIN BOARD A/I	R0319110	JUMPER WIRE AI/T 17.5mm	J79	1		
509	MAIN BOARD A/I	R0319110	JUMPER WIRE AI/T 7.5mm	J8	1		
510	MAIN BOARD A/I	R0319110	JUMPER WIRE AI/T 20mm	J80	1		
511	MAIN BOARD A/I	R0319110	JUMPER WIRE AI/T 12.5mm	J81	1		
512	MAIN BOARD A/I	R0319110	JUMPER WIRE AI/T 10mm	J82	1		
513	MAIN BOARD A/I	R0319110	JUMPER WIRE AI/T 10mm	J83	1		
514	MAIN BOARD A/I	R0319110	JUMPER WIRE AI/T 12.5mm	J84	1		
515	MAIN BOARD A/I	R0319110	JUMPER WIRE AI/T 20mm	J85	1		
516	MAIN BOARD A/I	R0319110	JUMPER WIRE AI/T 12.5mm	J86	1		
517	MAIN BOARD A/I	R0319110	JUMPER WIRE AI/T 10mm	J87	1		
518	MAIN BOARD A/I	R0319110	JUMPER WIRE AI/T 12.5mm	J88	1		
519	MAIN BOARD A/I	R0319110	JUMPER WIRE AI/T 15mm	J89	1		
520	MAIN BOARD A/I	R0319110	JUMPER WIRE AI/T 17.5mm	J9	1		
521	MAIN BOARD A/I	R0319110	JUMPER WIRE AI/T 15mm	J91	1		
522	MAIN BOARD A/I	R0319110	JUMPER WIRE AI/T 12.5mm	J92	1		
523	MAIN BOARD A/I	R0319110	JUMPER WIRE AI/T 10mm	J93	1		
524	MAIN BOARD A/I	R0319110	JUMPER WIRE AI/T 10mm	J94	1		
525	MAIN BOARD A/I	R0319110	JUMPER WIRE AI/T 10mm	J95	1		
526	MAIN BOARD A/I	R0319110	JUMPER WIRE AI/T 10mm	J96	1		
527	MAIN BOARD A/I	R0319110	JUMPER WIRE AI/T 12.5mm	J97	1		
528	MAIN BOARD A/I	R0319110	JUMPER WIRE AI/T 12.5mm	J98	1		
529	MAIN BOARD A/I	80000561	BEAD 3.5x6x0.8/T	J99	1		

530	MAIN BOARD A/I	R0319110	JUMPER WIRE AI/T 12.5mm	JP1	1		
531	MAIN BOARD A/I	R0319110	JUMPER WIRE AI/T 12.5mm	JP1	1		
532	MAIN BOARD A/I	R0319110	JUMPER WIRE AI/T 12.5mm	JP3	1		
533	MAIN BOARD A/I	R0319110	JUMPER WIRE AI/T 7.5mm	JP4	1		
534	MAIN BOARD A/I	R0319110	JUMPER WIRE AI/T 7.5mm	JP5	1		
535	MAIN BOARD A/I	R0319110	JUMPER WIRE AI/T 20mm	JP6	1		
536	MAIN BOARD A/I	R0319110	JUMPER WIRE AI/T 5mm	JP701	1		
537	MAIN BOARD A/I	R0319110	JUMPER WIRE AI/T 7.5mm	JP8	1		
538	MAIN BOARD A/I	R0319110	JUMPER WIRE AI/T 7.5mm	L308	1		
539	MAIN BOARD A/I	72000583	N0501,N0701 MAIN BOARD(V3)	MAIN PCB	1		
540	MAIN BOARD A/I	80003831	IC REGULATOR TL431 817B 4P	Q103	1		
541	MAIN BOARD A/I	EAA18157	TR NPN 2SC1815GR TO-92(T) (T.P.S.)	Q105	1		
542	MAIN BOARD A/I	EAA09456	TR NPN 2SC945P TO-92(T) (N.P.S.)	Q105	OR		
543	MAIN BOARD A/I	EAA23281	TR NPN KSC 2328A TO-92(T) (SAMSUNG)	Q106	1		
544	MAIN BOARD A/I	EAA22355	TR NPN 2SC2235Y TO-92(T) (TOSHIBA)	Q106	OR		
545	MAIN BOARD A/I	EAA18157	TR NPN 2SC1815GR TO-92(T) (T.P.S.)	Q107	1		
546	MAIN BOARD A/I	EAA09456	TR NPN 2SC945P TO-92(T) (N.P.S.)	Q107	OR		
547	MAIN BOARD A/I	EBA09281	TR PNP KSA 928A TO-92(T) (SAMSUNG)	Q108	1		
548	MAIN BOARD A/I	EBA10205	TR PNP 2SA1020Y TO-92(T)	Q108	OR		
549	MAIN BOARD A/I	EAA18157	TR NPN 2SC1815GR TO-92(T) (T.P.S.)	Q110	1		
550	MAIN BOARD A/I	EAA09456	TR NPN 2SC945P TO-92(T) (N.P.S.)	Q110	OR		
551	MAIN BOARD A/I	EBA04230	TR PNP BF423 TO-92(T)(T.P.)	Q112	1		
552	MAIN BOARD A/I	EAA18157	TR NPN 2SC1815GR TO-92(T) (T.P.S.)	Q113	1		
553	MAIN BOARD A/I	EAA09456	TR NPN 2SC945P TO-92(T) (N.P.S.)	Q113	OR		
554	MAIN BOARD A/I	EBA10157	TR PNP 2SA1015GR TO-92(T) (T.P.S.)	Q117	1		
555	MAIN BOARD A/I	EBA07336	TR PNP 2SA733P TO-92(T) (N.P.S.)	Q117	OR		
556	MAIN BOARD A/I	EAA23690	TR NPN PH2369 TO-92(T) (PHILIPS)	Q301	1		
557	MAIN BOARD A/I	EAA18157	TR NPN 2SC1815GR TO-92(T) (T.P.S.)	Q302	1		
558	MAIN BOARD A/I	EAA09456	TR NPN 2SC945P TO-92(T) (N.P.S.)	Q302	OR		
559	MAIN BOARD A/I	EAA40020	TR NPN 2SC4002 TO-92(T) (SANYO)	Q303	1		
560	MAIN BOARD A/I	EAA04220	TR NPN BF422 TO-92(T) (T,P)	Q304	1		
561	MAIN BOARD A/I	EBA04230	TR PNP BF423 TO-92(T)(T.P.)	Q305	1		
562	MAIN BOARD A/I	EAA18157	TR NPN 2SC1815GR TO-92(T) (T.P.S.)	Q306	1		
563	MAIN BOARD A/I	EAA09456	TR NPN 2SC945P TO-92(T) (N.P.S.)	Q306	OR		
564	MAIN BOARD A/I	EFA29610	TR 2SK2961 FET TOSHIBA	Q308	1		
565	MAIN BOARD A/I	EBA10157	TR PNP 2SA1015GR TO-92(T) (T.P.S.)	Q310	1		
566	MAIN BOARD A/I	EBA07336	TR PNP 2SA733P TO-92(T) (N.P.S.)	Q310	OR		
567	MAIN BOARD A/I	EBA00920	TR PNP KSP92 TO-92(T)	Q312	1	L,S	
568	MAIN BOARD A/I	EBA04230	TR PNP BF423 TO-92(T)(T.P.)	Q315	1		
569	MAIN BOARD A/I	EAA06673	TR NPN 2SD667AC TO-92(T) (HITACHI)	Q316	1		
570	MAIN BOARD A/I	EAA18157	TR NPN 2SC1815GR TO-92(T) (T.P.S.)	Q320	1		
571	MAIN BOARD A/I	EAA09456	TR NPN 2SC945P TO-92(T) (N.P.S.)	Q320	OR		
572	MAIN BOARD A/I	EAA18157	TR NPN 2SC1815GR TO-92(T) (T.P.S.)	Q323	1		
573	MAIN BOARD A/I	EAA09456	TR NPN 2SC945P TO-92(T) (N.P.S.)	Q323	OR		
574	MAIN BOARD A/I	EAA18157	TR NPN 2SC1815GR TO-92(T) (T.P.S.)	Q324	1		
575	MAIN BOARD A/I	EAA09456	TR NPN 2SC945P TO-92(T) (N.P.S.)	Q324	OR		
576	MAIN BOARD A/I	EAA18157	TR NPN 2SC1815GR TO-92(T) (T.P.S.)	Q401	1		
577	MAIN BOARD A/I	EAA09456	TR NPN 2SC945P TO-92(T) (N.P.S.)	Q401	OR		
578	MAIN BOARD A/I	EAA18157	TR NPN 2SC1815GR TO-92(T) (T.P.S.)	Q402	1		
579	MAIN BOARD A/I	EAA09456	TR NPN 2SC945P TO-92(T) (N.P.S.)	Q402	OR		
580	MAIN BOARD A/I	EAA18157	TR NPN 2SC1815GR TO-92(T) (T.P.S.)	Q601	1		
581	MAIN BOARD A/I	EAA09456	TR NPN 2SC945P TO-92(T) (N.P.S.)	Q601	OR		
582	MAIN BOARD A/I	EAA18157	TR NPN 2SC1815GR TO-92(T) (T.P.S.)	Q603	1		

583	MAIN BOARD A/I	EAA09456	TR NPN 2SC945P TO-92(T) (N.P.S.)	Q603	OR		
584	MAIN BOARD A/I	EBA10157	TR PNP 2SA1015GR TO-92(T) (T.P.S.)	Q604	1		
585	MAIN BOARD A/I	EBA07336	TR PNP 2SA733P TO-92(T) (N.P.S.)	Q604	OR		
586	MAIN BOARD A/I	EAA18157	TR NPN 2SC1815GR TO-92(T) (T.P.S.)	Q605	1		
587	MAIN BOARD A/I	EAA09456	TR NPN 2SC945P TO-92(T) (N.P.S.)	Q605	OR		
588	MAIN BOARD A/I	EAA18157	TR NPN 2SC1815GR TO-92(T) (T.P.S.)	Q606	1		
589	MAIN BOARD A/I	EAA09456	TR NPN 2SC945P TO-92(T) (N.P.S.)	Q606	OR		
590	MAIN BOARD A/I	EAA18157	TR NPN 2SC1815GR TO-92(T) (T.P.S.)	Q702	1		
591	MAIN BOARD A/I	EAA09456	TR NPN 2SC945P TO-92(T) (N.P.S.)	Q702	OR		
592	MAIN BOARD A/I	FA330684	CARBON 1/2W(T) 5% 680Kohm	R101	1		
593	MAIN BOARD A/I	FA040331	CARBON 1/8W(T) 5% 330ohm	R102	1		
594	MAIN BOARD A/I	FA240330	CARBON 1/4W(T) 5% 33 ohm	R104	1		
595	MAIN BOARD A/I	FA240564	CARBON 1/4W(T) 5% 560Kohm	R107	1		
596	MAIN BOARD A/I	FA240334	CARBON 1/4W(T) 5% 330Kohm	R108	1		
597	MAIN BOARD A/I	FA040470	CARBON 1/8W(T) 5% 47ohm	R109	1		
598	MAIN BOARD A/I	FA240113	CARBON 1/4W(T) 5% 11Kohm	R10A	1		
599	MAIN BOARD A/I	FA040472	CARBON 1/8W(T) 5% 4.7Kohm	R110	1		
600	MAIN BOARD A/I	FA040102	CARBON 1/8W(T) 5% 1Kohm	R112	1		
601	MAIN BOARD A/I	FA040752	CARBON 1/8W(T) 5% 7.5Kohm	R113	1		
602	MAIN BOARD A/I	FA330104	CARBON 1/2W(T) 5% 100Kohm	R114	1		
603	MAIN BOARD A/I	FA040390	CARBON 1/8W(T) 5% 39ohm	R115	1		
604	MAIN BOARD A/I	FA240271	CARBON 1/4W(T) 5% 270ohm	R116	1		
605	MAIN BOARD A/I	FA240390	CARBON 1/4W(T) 1% 39ohm	R117	1		
606	MAIN BOARD A/I	FA240203	CARBON 1/4W(T) 5% 20Kohm	R118	1		
607	MAIN BOARD A/I	FA040472	CARBON 1/8W(T) 5% 4.7Kohm	R119	1		
608	MAIN BOARD A/I	FA330104	CARBON 1/2W(T) 5% 100Kohm	R120	1		
609	MAIN BOARD A/I	FA040103	CARBON 1/8W(T) 5% 10Kohm	R122	1		
610	MAIN BOARD A/I	FA040102	CARBON 1/8W(T) 5% 1Kohm	R123	1		
611	MAIN BOARD A/I	FA240681	CARBON 1/4W(T) 5% 680ohm	R126	1		
612	MAIN BOARD A/I	FA040223	CARBON 1/8W(T) 5% 22Kohm	R127	1		
613	MAIN BOARD A/I	FA040472	CARBON 1/8W(T) 5% 4.7Kohm	R129	1		
614	MAIN BOARD A/I	FA040223	CARBON 1/8W(T) 5% 22Kohm	R130	1		
615	MAIN BOARD A/I	R0319110	JUMPER WIRE AI/T 15mm	R131	1		
616	MAIN BOARD A/I	FA040102	CARBON 1/8W(T) 5% 1Kohm	R132	1		
617	MAIN BOARD A/I	FA040330	CARBON 1/8W(T) 5% 33ohm	R135	1		
618	MAIN BOARD A/I	FA040102	CARBON 1/8W(T) 5% 1Kohm	R137	1		
619	MAIN BOARD A/I	FA240750	CARBON 1/4W(T) 5% 75ohm	R138	1		
620	MAIN BOARD A/I	FA330561	CARBON 1/2W(T) 5% 560ohm	R139	1		
621	MAIN BOARD A/I	FA040470	CARBON 1/8W(T) 5% 47ohm	R140	1		
622	MAIN BOARD A/I	FA040203	CARBON 1/8W(T) 5% 20Kohm	R141	1		
623	MAIN BOARD A/I	FA040224	CARBON 1/8W(T) 5% 220Kohm	R142	1		
624	MAIN BOARD A/I	FA040102	CARBON 1/8W(T) 5% 1Kohm	R144	1		
625	MAIN BOARD A/I	FA040273	CARBON 1/8W(T) 5% 27Kohm	R145	1		
626	MAIN BOARD A/I	FA040222	CARBON 1/8W(T) 5% 2.2Kohm	R146	1		
627	MAIN BOARD A/I	FA040202	CARBON 1/8W(T) 5% 2Kohm	R147	1		
628	MAIN BOARD A/I	FA040472	CARBON 1/8W(T) 5% 4.7Kohm	R148	1		
629	MAIN BOARD A/I	FB241051	METAL 1/4W(T) 1% 1.05Kohm	R149	1		
630	MAIN BOARD A/I	FB246242	METAL 1/4W(T) 1% 62.4Kohm	R151	1		
631	MAIN BOARD A/I	FA040332	CARBON 1/8W(T) 5% 3.3Kohm	R152	1		
632	MAIN BOARD A/I	FA040562	CARBON 1/8W(T) 5% 5.6Kohm	R154	1		
633	MAIN BOARD A/I	FA040104	CARBON 1/8W(T) 5% 100Kohm	R155	1		
634	MAIN BOARD A/I	FA330159	CARBON 1/2W(T) 5% 1.5ohm	R156	1		
635	MAIN BOARD A/I	R0319110	JUMPER WIRE AI/T 10mm	R157	1		

636	MAIN BOARD A/I	FB240470	METAL 1/4W(T) 1% 47ohm	R158	1		
637	MAIN BOARD A/I	FA040105	CARBON 1/8W(T) 5% 1Mohm	R159	1		
638	MAIN BOARD A/I	FA040202	CARBON 1/8W(T) 5% 2Kohm	R160	1		
639	MAIN BOARD A/I	FA040103	CARBON 1/8W(T) 5% 10Kohm	R161	1		
640	MAIN BOARD A/I	80000561	BEAD 3.5x6x0.8/T	R162	1		
641	MAIN BOARD A/I	FA240122	CARBON 1/4W(T) 5% 1.2Kohm	R163	1		
642	MAIN BOARD A/I	FA040103	CARBON 1/8W(T) 5% 10Kohm	R167	1		
643	MAIN BOARD A/I	FA040104	CARBON 1/8W(T) 5% 100Kohm	R168	1		
644	MAIN BOARD A/I	FB910010	METAL 1/4W(T) 5% 1ohm	R169	1		
645	MAIN BOARD A/I	FA040472	CARBON 1/8W(T) 5% 4.7Kohm	R173	1		
646	MAIN BOARD A/I	FA040103	CARBON 1/8W(T) 5% 10Kohm	R177	1		
647	MAIN BOARD A/I	FA040473	CARBON 1/8W(T) 5% 47Kohm	R178	1		
648	MAIN BOARD A/I	FA330102	CARBON 1/2W(T) 5% 1Kohm	R182	1		
649	MAIN BOARD A/I	FA040102	CARBON 1/8W(T) 5% 1Kohm	R301	1		
650	MAIN BOARD A/I	FA040561	CARBON 1/8W(T) 5% 560ohm	R303	1		
651	MAIN BOARD A/I	FA040225	CARBON 1/8W(T) 5% 2.2Mohm	R305	1		
652	MAIN BOARD A/I	FA040101	CARBON 1/8W(T) 5% 100ohm	R306	1		
653	MAIN BOARD A/I	FA040103	CARBON 1/8W(T) 5% 10Kohm	R307	1		
654	MAIN BOARD A/I	FA330561	CARBON 1/2W(T) 5% 560ohm	R308	1		
655	MAIN BOARD A/I	FA040224	CARBON 1/8W(T) 5% 220Kohm	R30C	1		
656	MAIN BOARD A/I	FA040224	CARBON 1/8W(T) 5% 220Kohm	R30E	1		
657	MAIN BOARD A/I	FA240105	CARBON 1/4W(T) 5% 1Mohm	R30H	1	L,S	
658	MAIN BOARD A/I	R0319110	JUMPER WIRE A/I/T 10mm	R30H	1	T	
659	MAIN BOARD A/I	FA240105	CARBON 1/4W(T) 5% 1Mohm	R30J	1	L,S	
660	MAIN BOARD A/I	R0319110	JUMPER WIRE A/I/T 10mm	R30J	1	T	
661	MAIN BOARD A/I	FA040103	CARBON 1/8W(T) 5% 10Kohm	R310	1		
662	MAIN BOARD A/I	FB910010	METAL 1/4W(T) 5% 1ohm	R313	1		
663	MAIN BOARD A/I	FB910010	METAL 1/4W(T) 5% 1ohm	R314	1		
664	MAIN BOARD A/I	FA040105	CARBON 1/8W(T) 5% 1Mohm	R315	1		
665	MAIN BOARD A/I	FA040395	CARBON 1/8W(T) 5% 3.9Mohm	R317	1	L,S	
666	MAIN BOARD A/I	FA040475	CARBON 1/8W(T) 5% 4.7Mohm	R317	1	T	
667	MAIN BOARD A/I	FA040103	CARBON 1/8W(T) 5% 10Kohm	R318	1		
668	MAIN BOARD A/I	FA040823	CARBON 1/8W(T) 5% 82Kohm	R319	1		
669	MAIN BOARD A/I	FA040122	CARBON 1/8W(T) 5% 1.2Kohm	R322	1		
670	MAIN BOARD A/I	FA240124	CARBON 1/4W(T) 5% 120Kohm	R323	1	L,S	
671	MAIN BOARD A/I	FA240124	CARBON 1/4W(T) 5% 120Kohm	R324	1	L,S	
672	MAIN BOARD A/I	FA040393	CARBON 1/8W(T) 5% 39Kohm	R325	1		
673	MAIN BOARD A/I	FA040472	CARBON 1/8W(T) 5% 4.7Kohm	R326	1		
674	MAIN BOARD A/I	FA040104	CARBON 1/8W(T) 5% 100Kohm	R327	1		
675	MAIN BOARD A/I	FA040473	CARBON 1/8W(T) 5% 47Kohm	R328	1		
676	MAIN BOARD A/I	FA040822	CARBON 1/8W(T) 5% 8.2Kohm	R329	1		
677	MAIN BOARD A/I	FA040103	CARBON 1/8W(T) 5% 10Kohm	R330	1		
678	MAIN BOARD A/I	FA040153	CARBON 1/8W(T) 5% 15Kohm	R331	1		
679	MAIN BOARD A/I	FA040472	CARBON 1/8W(T) 5% 4.7Kohm	R332	1		
680	MAIN BOARD A/I	FA040333	CARBON 1/8W(T) 5% 33Kohm	R333	1	L,S	
681	MAIN BOARD A/I	FA040102	CARBON 1/8W(T) 5% 1Kohm	R334	1	L,S	
682	MAIN BOARD A/I	FA040392	CARBON 1/8W(T) 5% 3.9Kohm	R336	1		
683	MAIN BOARD A/I	FA040333	CARBON 1/8W(T) 5% 33Kohm	R337	1		
684	MAIN BOARD A/I	FA240243	CARBON 1/4W(T) 5% 24Kohm	R338	1		
685	MAIN BOARD A/I	FA040224	CARBON 1/8W(T) 5% 220Kohm	R339	1		
686	MAIN BOARD A/I	FA040104	CARBON 1/8W(T) 5% 100Kohm	R340	1		
687	MAIN BOARD A/I	FA040103	CARBON 1/8W(T) 5% 10Kohm	R343	1		
688	MAIN BOARD A/I	FA330102	CARBON 1/2W(T) 5% 1Kohm	R344	1		



689	MAIN BOARD A/I	FA040103	CARBON 1/8W(T) 5% 10Kohm	R345	1		
690	MAIN BOARD A/I	FB241301	METAL 1/4W(T) 1% 1.3Kohm	R346	1		
691	MAIN BOARD A/I	FB242801	METAL 1/4W(T) 1% 2.8Kohm	R347	1	T	
692	MAIN BOARD A/I	FB242871	METAL 1/4W(T) 1% 2.87Kohm	R347	1	L,S	
693	MAIN BOARD A/I	FA330913	CARBON 1/2W(T) 5% 91Kohm	R348	1		
694	MAIN BOARD A/I	FA240243	CARBON 1/4W(T) 5% 24Kohm	R350	1		
695	MAIN BOARD A/I	FB910010	METAL 1/4W(T) 5% 1ohm	R351	1		
696	MAIN BOARD A/I	FB241132	METAL 1/4W(T) 1% 11.3Kohm	R352	1		
697	MAIN BOARD A/I	FA040104	CARBON 1/8W(T) 5% 100Kohm	R353	1		
698	MAIN BOARD A/I	FA040224	CARBON 1/8W(T) 5% 220Kohm	R354	1		
699	MAIN BOARD A/I	FA040102	CARBON 1/8W(T) 5% 1Kohm	R355	1		
700	MAIN BOARD A/I	FA040153	CARBON 1/8W(T) 5% 15Kohm	R357	1		
701	MAIN BOARD A/I	FA040684	CARBON 1/8W(T) 5% 680Kohm	R358	1		
702	MAIN BOARD A/I	FA040473	CARBON 1/8W(T) 5% 47Kohm	R359	1		
703	MAIN BOARD A/I	FA040103	CARBON 1/8W(T) 5% 10Kohm	R360	1		
704	MAIN BOARD A/I	FA040103	CARBON 1/8W(T) 5% 10Kohm	R361	1		
705	MAIN BOARD A/I	FA040474	CARBON 1/8W(T) 5% 470Kohm	R362	1		
706	MAIN BOARD A/I	FA040104	CARBON 1/8W(T) 5% 100Kohm	R363	1		
707	MAIN BOARD A/I	FA040472	CARBON 1/8W(T) 5% 4.7Kohm	R364	1		
708	MAIN BOARD A/I	FA330154	CARBON 1/2W(T) 5% 150Kohm	R365	1		
709	MAIN BOARD A/I	FB241203	METAL 1/4W(T) 1% 120Kohm	R366	1	T	
710	MAIN BOARD A/I	FB242053	METAL 1/4W(T) 1% 205Kohm	R366	1	L,S	
711	MAIN BOARD A/I	FA330105	CARBON 1/2W(T) 5% 1Mohm	R367	1		
712	MAIN BOARD A/I	FB241872	METAL 1/4W(T) 1% 18.7Kohm	R368	1		
713	MAIN BOARD A/I	FA040103	CARBON 1/8W(T) 5% 10Kohm	R369	1		
714	MAIN BOARD A/I	FA040822	CARBON 1/8W(T) 5% 8.2Kohm	R371	1		
715	MAIN BOARD A/I	FA040222	CARBON 1/8W(T) 5% 2.2Kohm	R372	1		
716	MAIN BOARD A/I	FB243161	METAL 1/4W(T) 1% 3.16Kohm	R373	1		
717	MAIN BOARD A/I	FB241002	METAL 1/4W(T) 1% 10Kohm	R374	1		
718	MAIN BOARD A/I	FA040104	CARBON 1/8W(T) 5% 100Kohm	R375	1		
719	MAIN BOARD A/I	FA040103	CARBON 1/8W(T) 5% 10Kohm	R377	1		
720	MAIN BOARD A/I	FA040103	CARBON 1/8W(T) 5% 10Kohm	R379	1		
721	MAIN BOARD A/I	FA330105	CARBON 1/2W(T) 5% 1Mohm	R380	1		
722	MAIN BOARD A/I	FA330105	CARBON 1/2W(T) 5% 1Mohm	R381	1		
723	MAIN BOARD A/I	FA040472	CARBON 1/8W(T) 5% 4.7Kohm	R383	1		
724	MAIN BOARD A/I	FA330150	CARBON 1/2W(T) 5% 15ohm	R385	1		
725	MAIN BOARD A/I	FB241002	METAL 1/4W(T) 1% 10Kohm	R386	1		
726	MAIN BOARD A/I	FA040132	CARBON 1/8W(T) 5% 1.3Kohm	R387	1		
727	MAIN BOARD A/I	FB246040	METAL 1/4W(T) 1% 604ohm	R388	1	T	
728	MAIN BOARD A/I	FB246490	METAL 1/4W(T) 1% 649ohm	R388	1	L	
729	MAIN BOARD A/I	FB247320	METAL 1/4W(T) 1% 732ohm	R388	1	S	
730	MAIN BOARD A/I	FB241372	METAL 1/4W(T) 1% 13.7Kohm	R389	1		
731	MAIN BOARD A/I	FA040153	CARBON 1/8W(T) 5% 15Kohm	R390	1		
732	MAIN BOARD A/I	FA240154	CARBON 1/4W(T) 5% 150Kohm	R392	1		
733	MAIN BOARD A/I	FA240224	CARBON 1/4W(T) 5% 220Kohm	R393	1		
734	MAIN BOARD A/I	FA040474	CARBON 1/8W(T) 5% 470Kohm	R394	1		
735	MAIN BOARD A/I	FA040105	CARBON 1/8W(T) 5% 1Mohm	R395	1		
736	MAIN BOARD A/I	FA040102	CARBON 1/8W(T) 5% 1Kohm	R401	1		
737	MAIN BOARD A/I	FA040472	CARBON 1/8W(T) 5% 4.7Kohm	R402	1		
738	MAIN BOARD A/I	FA040472	CARBON 1/8W(T) 5% 4.7Kohm	R403	1		
739	MAIN BOARD A/I	FA040224	CARBON 1/8W(T) 5% 220Kohm	R404	1		
740	MAIN BOARD A/I	FA040103	CARBON 1/8W(T) 5% 10Kohm	R405	1		
741	MAIN BOARD A/I	FA040472	CARBON 1/8W(T) 5% 4.7Kohm	R406	1		

742	MAIN BOARD A/I	FA040473	CARBON 1/8W(T) 5% 47Kohm	R407	1		
743	MAIN BOARD A/I	FA040471	CARBON 1/8W(T) 5% 470ohm	R408	1		
744	MAIN BOARD A/I	FA040473	CARBON 1/8W(T) 5% 47Kohm	R409	1		
745	MAIN BOARD A/I	FA040471	CARBON 1/8W(T) 5% 470ohm	R40A	1		
746	MAIN BOARD A/I	FB246801	METAL 1/4W(T) 1% 6.8Kohm	R410	1		
747	MAIN BOARD A/I	FB241002	METAL 1/4W(T) 1% 10Kohm	R411	1		
748	MAIN BOARD A/I	FB246801	METAL 1/4W(T) 1% 6.8Kohm	R412	1		
749	MAIN BOARD A/I	FB248202	METAL 1/4W(T) 1% 82Kohm	R413	1		
750	MAIN BOARD A/I	FA330331	CARBON 1/2W(T) 5% 330ohm	R414	1		
751	MAIN BOARD A/I	FA040472	CARBON 1/8W(T) 5% 4.7Kohm	R416	1		
752	MAIN BOARD A/I	FA330159	CARBON 1/2W(T) 5% 1.5ohm	R417	1		
753	MAIN BOARD A/I	FA040103	CARBON 1/8W(T) 5% 10Kohm	R418	1		
754	MAIN BOARD A/I	FA040134	CARBON 1/8W(T) 5% 130K	R419	1	L,S	
755	MAIN BOARD A/I	FA040224	CARBON 1/8W(T) 5% 220Kohm	R419	1	T	
756	MAIN BOARD A/I	FA040134	CARBON 1/8W(T) 5% 130K	R420	1		
757	MAIN BOARD A/I	FA040153	CARBON 1/8W(T) 5% 15Kohm	R423	1		
758	MAIN BOARD A/I	FA040473	CARBON 1/8W(T) 5% 47Kohm	R430	1		
759	MAIN BOARD A/I	FA040102	CARBON 1/8W(T) 5% 1Kohm	R432	1		
760	MAIN BOARD A/I	FA040473	CARBON 1/8W(T) 5% 47Kohm	R433	1		
761	MAIN BOARD A/I	FA040223	CARBON 1/8W(T) 5% 22Kohm	R440	1		
762	MAIN BOARD A/I	FA040472	CARBON 1/8W(T) 5% 4.7Kohm	R442	1		
763	MAIN BOARD A/I	FA040103	CARBON 1/8W(T) 5% 10Kohm	R443	1		
764	MAIN BOARD A/I	FA040472	CARBON 1/8W(T) 5% 4.7Kohm	R444	1		
765	MAIN BOARD A/I	FA040103	CARBON 1/8W(T) 5% 10Kohm	R447	1		
766	MAIN BOARD A/I	FA040103	CARBON 1/8W(T) 5% 10Kohm	R449	1		
767	MAIN BOARD A/I	FA040823	CARBON 1/8W(T) 5% 82Kohm	R450	1		
768	MAIN BOARD A/I	FA240103	CARBON 1/4W(T) 5% 10Kohm	R451	1		
769	MAIN BOARD A/I	FA040472	CARBON 1/8W(T) 5% 4.7Kohm	R452	1		
770	MAIN BOARD A/I	FA040473	CARBON 1/8W(T) 5% 47Kohm	R454	1		
771	MAIN BOARD A/I	FA040304	CARBON 1/8W(T) 5% 300Kohm	R455	1		
772	MAIN BOARD A/I	FA040822	CARBON 1/8W(T) 5% 8.2Kohm	R456	1		
773	MAIN BOARD A/I	FA040103	CARBON 1/8W(T) 5% 10Kohm	R457	1		
774	MAIN BOARD A/I	FA040244	CARBON 1/8W(T) 5% 240Kohm	R458	1		
775	MAIN BOARD A/I	FA040104	CARBON 1/8W(T) 5% 100Kohm	R459	1		
776	MAIN BOARD A/I	FA040103	CARBON 1/8W(T) 5% 10Kohm	R460	1		
777	MAIN BOARD A/I	FA040103	CARBON 1/8W(T) 5% 10Kohm	R601	1		
778	MAIN BOARD A/I	FA040472	CARBON 1/8W(T) 5% 4.7Kohm	R602	1		
779	MAIN BOARD A/I	FA040102	CARBON 1/8W(T) 5% 1Kohm	R603	1		
780	MAIN BOARD A/I	FA040103	CARBON 1/8W(T) 5% 10Kohm	R604	1		
781	MAIN BOARD A/I	FA040472	CARBON 1/8W(T) 5% 4.7Kohm	R605	1		
782	MAIN BOARD A/I	FA040222	CARBON 1/8W(T) 5% 2.2Kohm	R608	1		
783	MAIN BOARD A/I	FA240222	CARBON 1/4W(T) 5% 2.2Kohm	R609	1		
784	MAIN BOARD A/I	FA040472	CARBON 1/8W(T) 5% 4.7Kohm	R610	1		
785	MAIN BOARD A/I	FA040223	CARBON 1/8W(T) 5% 22Kohm	R611	1		
786	MAIN BOARD A/I	FA040103	CARBON 1/8W(T) 5% 10Kohm	R612	1		
787	MAIN BOARD A/I	FA040103	CARBON 1/8W(T) 5% 10Kohm	R613	1		
788	MAIN BOARD A/I	FA040472	CARBON 1/8W(T) 5% 4.7Kohm	R701	1		
789	MAIN BOARD A/I	FA040472	CARBON 1/8W(T) 5% 4.7Kohm	R704	1		
790	MAIN BOARD A/I	FA040103	CARBON 1/8W(T) 5% 10Kohm	R705	1		
791	MAIN BOARD A/I	FA040101	CARBON 1/8W(T) 5% 100ohm	R706	1		
792	MAIN BOARD A/I	FA040101	CARBON 1/8W(T) 5% 100ohm	R707	1		
793	MAIN BOARD A/I	FA040331	CARBON 1/8W(T) 5% 330ohm	R708	1		
794	MAIN BOARD A/I	FA040103	CARBON 1/8W(T) 5% 10Kohm	R709	1		

795	MAIN BOARD A/I	FA040472	CARBON 1/8W(T) 5% 4.7Kohm	R710	1		
796	MAIN BOARD A/I	FA040472	CARBON 1/8W(T) 5% 4.7Kohm	R713	1		
797	MAIN BOARD A/I	FA040102	CARBON 1/8W(T) 5% 1Kohm	R714	1		
798	MAIN BOARD A/I	FA040472	CARBON 1/8W(T) 5% 4.7Kohm	R715	1		
799	MAIN BOARD A/I	FA040472	CARBON 1/8W(T) 5% 4.7Kohm	R716	1		
800	MAIN BOARD A/I	FA040472	CARBON 1/8W(T) 5% 4.7Kohm	R717	1		
801	MAIN BOARD A/I	FA040472	CARBON 1/8W(T) 5% 4.7Kohm	R718	1		
802	MAIN BOARD A/I	FA040102	CARBON 1/8W(T) 5% 1Kohm	R719	1		
803	MAIN BOARD A/I	FA040103	CARBON 1/8W(T) 5% 10Kohm	R720	1		
804	MAIN BOARD A/I	FA040152	CARBON 1/8W(T) 5% 1.5Kohm	R721	1		
805	MAIN BOARD A/I	FA040472	CARBON 1/8W(T) 5% 4.7Kohm	R722	1		
806	MAIN BOARD A/I	FA240103	CARBON 1/4W(T) 5% 10Kohm	R725	1		
807	MAIN BOARD A/I	FA040242	CARBON 1/8W(T) 5% 2.4Kohm	R726	1		
808	MAIN BOARD A/I	FA040472	CARBON 1/8W(T) 5% 4.7Kohm	R728	1		
809	MAIN BOARD A/I	FA040472	CARBON 1/8W(T) 5% 4.7Kohm	R729	1		
810	MAIN BOARD A/I	FA040472	CARBON 1/8W(T) 5% 4.7Kohm	R733	1		
811	MAIN BOARD A/I	FA040222	CARBON 1/8W(T) 5% 2.2Kohm	R735	1		
812	MAIN BOARD A/I	FA040103	CARBON 1/8W(T) 5% 10Kohm	R736	1		
813	MAIN BOARD A/I	FA040104	CARBON 1/8W(T) 5% 100Kohm	R737	1		
814	MAIN BOARD A/I	FA040471	CARBON 1/8W(T) 5% 470ohm	R739	1		
815	MAIN BOARD A/I	FA040471	CARBON 1/8W(T) 5% 470ohm	R740	1		
816	MAIN BOARD A/I	FA040101	CARBON 1/8W(T) 5% 100ohm	R742	1		
817	MAIN BOARD A/I	FA040101	CARBON 1/8W(T) 5% 100ohm	R743	1		
818	MAIN BOARD A/I	FA040101	CARBON 1/8W(T) 5% 100ohm	R761	1		
819	MAIN BOARD A/I	FA040101	CARBON 1/8W(T) 5% 100ohm	R762	1		
820	MAIN BOARD A/I	FA040472	CARBON 1/8W(T) 5% 4.7Kohm	R768	1		
821	MAIN BOARD A/I	FA040472	CARBON 1/8W(T) 5% 4.7Kohm	R769	1		
822	MAIN BOARD A/I	FA040472	CARBON 1/8W(T) 5% 4.7Kohm	R770	1		
823	MAIN BOARD A/I	FA040471	CARBON 1/8W(T) 5% 470ohm	R771	1		
824	MAIN BOARD A/I	R0319110	JUMPER WIRE AI/T 7.5mm	VR307	1	L,S	
825	MAIN BOARD A/I	EKA0180B	ZEN DIODE 1/2W(T) HZS 18-2 (HITACHI)	ZD101	1		
826	MAIN BOARD A/I	EKC0180B	ZEN DIODE 1/2W(T) BZX79F18 (PHILIPS)	ZD101	OR		
827	MAIN BOARD A/I	EKA01201	ZEN DIODE 1/2W(T) HZS12A2 (HITACHI)	ZD102	1		
828	MAIN BOARD A/I	EKC01201	ZEN DIODE 1/2W(T) BZX79F12 (PHILIPS)	ZD102	OR		
829	MAIN BOARD A/I	EKA00507	ZEN DIODE 1/2W(T) HZS5C2 (HITACHI)	ZD104	1		
830	MAIN BOARD A/I	EKC00507	ZEN DIODE 1/2W(T) BZX79F5V1 (PHILIPS)	ZD104	OR		
831	MAIN BOARD A/I	EKA01201	ZEN DIODE 1/2W(T) HZS12A2 (HITACHI)	ZD301	1		
832	MAIN BOARD A/I	EKC01201	ZEN DIODE 1/2W(T) BZX79F12 (PHILIPS)	ZD301	OR		
833	MAIN BOARD A/I	EKA00507	ZEN DIODE 1/2W(T) HZS5C2 (HITACHI)	ZD303	1		
834	MAIN BOARD A/I	EKC00507	ZEN DIODE 1/2W(T) BZX79F5V1 (PHILIPS)	ZD303	OR		
835	MAIN BOARD A/I	EKA00507	ZEN DIODE 1/2W(T) HZS5C2 (HITACHI)	ZD701	1		
836	MAIN BOARD A/I	EKC00507	ZEN DIODE 1/2W(T) BZX79F5V1 (PHILIPS)	ZD701	OR		
837	MAIN BOARD A/I	EKA00507	ZEN DIODE 1/2W(T) HZS5C2 (HITACHI)	ZD702	1		
838	MAIN BOARD A/I	EKC00507	ZEN DIODE 1/2W(T) BZX79F5V1 (PHILIPS)	ZD702	OR		
839	MAIN BOARD A/I	EKA00507	ZEN DIODE 1/2W(T) HZS5C2 (HITACHI)	ZD703	1		
840	MAIN BOARD A/I	EKC00507	ZEN DIODE 1/2W(T) BZX79F5V1 (PHILIPS)	ZD703	OR		
841	MAIN BOARD A/I	EKA00507	ZEN DIODE 1/2W(T) HZS5C2 (HITACHI)	ZD704	1		
842	MAIN BOARD A/I	EKC00507	ZEN DIODE 1/2W(T) BZX79F5V1 (PHILIPS)	ZD704	OR		
843	MAIN BOARD INSERT	14000051	SCREW (#2CBRITS*4*8*15BF)	AC SOCKET	2		
844	MAIN BOARD INSERT	80000991	BEAD WBR6H-3T-R7K-B5	B102	1		
845	MAIN BOARD INSERT	GJ047400	SAFETY X-CAP 0.47u/275V M	C101	1		
846	MAIN BOARD INSERT	80010661	EPCOS B81130 X-CAP	C101	OR		
847	MAIN BOARD INSERT	GJ047404	SAFETY X-CAP 0.47u/275V M(ISKRA)	C101	OR		

848	MAIN BOARD INSERT	GJ047405	SAFETY X-CAP 0.47u/275V M(PHILIPS)	C101	OR		
849	MAIN BOARD INSERT	GJ047407	SAFETY X-CAP 0.47u/275V M(OKAYA)	C101	OR		
850	MAIN BOARD INSERT	GJ047409	SAFETY X-CAP 0.47u/250V M(PILKOR)	C101	OR		
851	MAIN BOARD INSERT	GJ04740A	SAFETY X-CAP 0.47u/275V M(EPCOS B81130)	C101	OR		
852	MAIN BOARD INSERT	GJH102E5	SAFETY Y-CAP/S 1000P/400V M	C103	1		
853	MAIN BOARD INSERT	GJH102E5	SAFETY Y-CAP/S 1000P/400V M	C104	1		
854	MAIN BOARD INSERT	GKA227E5	POWER ELECT 85oC 220u/400V M	C105	1		
855	MAIN BOARD INSERT	GAI10775	ELECT 85oC/A 100u/100V M TK	C120	1		
856	MAIN BOARD INSERT	80011091	ELECT LOW ESR 100u/100V M TK	C120	OR		
857	MAIN BOARD INSERT	GA310815	ELECT 85oC/T 1000u/10V M	C122	1		
858	MAIN BOARD INSERT	GAA47685	ELECT 85oC/A 47u/250V M	C129	1		
859	MAIN BOARD INSERT	GAI10775	ELECT 85oC/A 100u/100V M TK	C138	1		
860	MAIN BOARD INSERT	80011091	ELECT LOW ESR 100u/100V M TK	C138	OR		
861	MAIN BOARD INSERT	GFA33382	PLASTIC MPE/A 0.033u/250V J	C143	1		
862	MAIN BOARD INSERT	GJH102E5	SAFETY Y-CAP/S 1000P/400V M	C146	1		
863	MAIN BOARD INSERT	GJC222E5	SAFETY Y-CAP/D 2200P/400V M	C147	1		
864	MAIN BOARD INSERT	GJH102E5	SAFETY Y-CAP/S 1000P/400V M	C154	1		
865	MAIN BOARD INSERT	GB8103F5	CERAMIC Z5U(E)/T 0.01u/500V M	C310	1		
866	MAIN BOARD INSERT	GFC512J2	PLASTIC PPS/A 5100P/2KV J	C318	1	T,S	
867	MAIN BOARD INSERT	GFC532J2	PLASTIC PPS/A 5300P/2KV J	C318	1	L	
868	MAIN BOARD INSERT	GED682M2	PLASTIC PPN/A 6800P/800V J	C319	1	L,T	
869	MAIN BOARD INSERT	GED752M2	PLASTIC PPN/A 7500P/800V J	C319	1	S	
870	MAIN BOARD INSERT	GB9103H8	CERAMIC Z5V(F)/T 0.01u/1KV Z	C321	1		
871	MAIN BOARD INSERT	GAB22685	ELECT 105oC/T 22u/250V M	C325	1		
872	MAIN BOARD INSERT	GFA15482	PLASTIC MPE/A 0.15u/250V J	C329	1		
873	MAIN BOARD INSERT	GFD274E2	PLASTIC 378/A 0.27u/400V J (PILKOR)	C332	1		
874	MAIN BOARD INSERT	GFD27482	PLASTIC PMM/A 0.27u/250V J (MYLAR)	C332	OR		
875	MAIN BOARD INSERT	GFA10582	PLASTIC MPE/A 1u/250V J	C333	1		
876	MAIN BOARD INSERT	GFA10382	PLASTIC MPE/A 0.01u/250V J	C345	1		
877	MAIN BOARD INSERT	GFB10482	PLASTIC MPP/A 0.1u/250VJ	C351	1		
878	MAIN BOARD INSERT	GFB56482	PLASTIC MPP/A 0.56u/250V J	C355	1		
879	MAIN BOARD INSERT	GFB33482	PLASTIC MPP/A 0.33u/250V J	C356	1		
880	MAIN BOARD INSERT	EJB20001	DIODE/A 3A 1N5406	D101	1		
881	MAIN BOARD INSERT	EJB20001	DIODE/A 3A 1N5406	D102	1		
882	MAIN BOARD INSERT	EJB20001	DIODE/A 3A 1N5406	D103	1		
883	MAIN BOARD INSERT	EJB20001	DIODE/A 3A 1N5406	D104	1		
884	MAIN BOARD INSERT	80003561	DIODE 600V/1.6A RG2A SANKEN s	D110	1		
885	MAIN BOARD INSERT	80003581	DIODE 600V/2A UF2005 CHENMKO s	D110	OR		
886	MAIN BOARD INSERT	80011241	DIODE SANKEN 3A/400V RG4 s (A+K)	D111	1		
887	MAIN BOARD INSERT	80003551	DIODE 200V/1.6A RG2Z SANKEN s	D112	1		
888	MAIN BOARD INSERT	80003571	DIODE 200V/2A UF2003 CHENMKO s	D112	OR		
889	MAIN BOARD INSERT	80003551	DIODE 200V/1.6A RG2Z SANKEN s	D113	1		
890	MAIN BOARD INSERT	80003571	DIODE 200V/2A UF2003 CHENMKO s	D113	OR		
891	MAIN BOARD INSERT	80003561	DIODE 600V/1.6A RG2A SANKEN s	D114	1		
892	MAIN BOARD INSERT	80003551	DIODE 200V/1.6A RG2Z SANKEN s	D118	1		
893	MAIN BOARD INSERT	80003571	DIODE 200V/2A UF2003 CHENMKO s	D118	OR		
894	MAIN BOARD INSERT	14000041	SCREW (P-#2CBRITS*3*8*15BF)	D307	1		
895	MAIN BOARD INSERT	80001171	DIODE/A 5TUZ47C (TOSHIBA)	D307	1		
896	MAIN BOARD INSERT	80009541	DIODE FAGOR FUF5406 s (A+K)	D308	1		
897	MAIN BOARD INSERT	80001131	DIODE/A 2A/600V RG4A ( s )	D308	OR		
898	MAIN BOARD INSERT	80009261	DIODE SANKEN RP3F s (A+K)	D316	1		
899	MAIN BOARD INSERT	80010981	DIODE TOSHIBA 3TH41 s (A+K)	D316	OR		
900	MAIN BOARD INSERT	80001521	FUSE 3.15A/250V 50T T3.15A	F101	1		

901	MAIN BOARD INSERT	14000071	SCREW (PL-CPTS*3*8*15BF)	FOR FBT	3		
902	MAIN BOARD INSERT	R0180028	FUSE HOLDER 5X20mm	FOR FUSE	2		
903	MAIN BOARD INSERT	80010631	JUMPER 2.54mm	FOR SW301	1		
904	MAIN BOARD INSERT	80000781	SINGLE PIN L=12.0 D=1.5	FOR TH101	2		
905	MAIN BOARD INSERT	JD010040	IC SOCKET 40P	FOR U701	1		
906	MAIN BOARD INSERT	80011481	17" G2 PIN WIRE	G2 WIRE	1		
907	MAIN BOARD INSERT	HA030010	EMI FILTER COIL 20.45X10.2X10	G2,G4 WIRE	2		
908	MAIN BOARD INSERT	80007031	WIRE GND CHOKE 60mm Y/G 1015 18A 3T	L100	1		
909	MAIN BOARD INSERT	80000111	LINE FILTER ET24 10mH MIN	L101	1		
910	MAIN BOARD INSERT	HB000015	LINE FILTER UU10.5 1mH	L102	1		
911	MAIN BOARD INSERT	80003681	CHOKE T50-26B 200uH	L103	1		
912	MAIN BOARD INSERT	80010671	N0501 DC-DC 180uH COIL	L106	1		
913	MAIN BOARD INSERT	80009291	H-CENTER CHOKE	L301	1		
914	MAIN BOARD INSERT	80001811	CHOKE COIL 130uH 18X20 + BASE	L303	1		
915	MAIN BOARD INSERT	80010391	N0501 LINEARITY CHOKE	L306	1		
916	MAIN BOARD INSERT	80005421	FOR 17" SAMSUNG LINEARITY	L307	1		
917	MAIN BOARD INSERT	80000131	LED L-59GH/1GYC	LED701	1		
918	MAIN BOARD INSERT	18000331	CABLE CLIP(WC-13T)	LW101	1		
919	MAIN BOARD INSERT	JD512001	AC SOCKET 3P	P101	1		
920	MAIN BOARD INSERT	R0224301	BASE PIN 1.55 P=5/7.5 2P	P102	1		
921	MAIN BOARD INSERT	12800032	HEAT SINK 40*12*50 B	Q101	1		
922	MAIN BOARD INSERT	14000041	SCREW (P-#2CBRITS*3*8*15BF)	Q101	1		
923	MAIN BOARD INSERT	EF202500	FET N 2SK2545 TO-220F TOSHIBA	Q101	1		
924	MAIN BOARD INSERT	80000901	FET N FS7KM-12 600V/7A TO-220F	Q101	OR		
925	MAIN BOARD INSERT	80000981	FET N 2SK2645-01/MR TO-220F	Q101	OR		
926	MAIN BOARD INSERT	EF211180	FET N 2SK1118 TO-220F	Q101	OR		
927	MAIN BOARD INSERT	12800041	HEAT SINK 23*17*25	Q102	1		
928	MAIN BOARD INSERT	14000041	SCREW (P-#2CBRITS*3*8*15BF)	Q102	1		
929	MAIN BOARD INSERT	EF206301	FET N YTAF630 TO-220F	Q102	1		
930	MAIN BOARD INSERT	EB307720	TRPNP KSB772 TO-126	Q104	1		
931	MAIN BOARD INSERT	80000201	TR PNP 2SB1273 S/R	Q104	OR		
932	MAIN BOARD INSERT	80002451	TR PNP 2SB1274 S/R (SANYO)	Q104	OR		
933	MAIN BOARD INSERT	12600231	HEAT SINK (FBT)	Q307	1		
934	MAIN BOARD INSERT	80005561	TR NPN BU2520DF TO3P	Q307	1	L,S	
935	MAIN BOARD INSERT	EA853870	TR NPN 2SC53387hfE) TO-3P	Q307	1	T	
936	MAIN BOARD INSERT	R0311D04	SCREW CTTWC M3.0X10	Q307	1		
937	MAIN BOARD INSERT	80005571	TR NPN BU2520DX TO3P	Q307	OR	L,S	
938	MAIN BOARD INSERT	EF206301	FET N YTAF630 TO-220F	Q313	1		
939	MAIN BOARD INSERT	EB20861A	TR PNP 2SB861C TO-220F	Q314	1		
940	MAIN BOARD INSERT	R0311D04	SCREW CTTWC M3.0X10	Q314	1		
941	MAIN BOARD INSERT	12800061	HEAT SINK 15*25*10.5	Q322	1		
942	MAIN BOARD INSERT	14000041	SCREW (P-#2CBRITS*3*8*15BF)	Q322	1		
943	MAIN BOARD INSERT	EF206301	FET N YTAF630 TO-220F	Q322	1		
944	MAIN BOARD INSERT	FB470680	MOF 1W/M(A) 5% 68ohm	R103	1		
945	MAIN BOARD INSERT	FB560248	MOF 2W/M(A) 5% 0.24ohm	R105	1	L,S	
946	MAIN BOARD INSERT	FB560278	MOF 2W/M(A) 5% 0.27ohm	R105	1	T	
947	MAIN BOARD INSERT	FB570563	MOF 2W/M(B) 5% 56Kohm	R106	1		
948	MAIN BOARD INSERT	FC110158	WOUND RES 2W(A) 5% 0.15ohm	R111	1		
949	MAIN BOARD INSERT	FB560103	MOF 2W/M(A) 5% 10Kohm	R125	1		
950	MAIN BOARD INSERT	FB470100	MOF 1W/M(A) 5% 10ohm	R128	1		
951	MAIN BOARD INSERT	FB560152	MOF 2W/M(A) 5% 1.5Kohm	R134	1		
952	MAIN BOARD INSERT	FC030278	WOUND RES 1W/M(A) 5% 0.27ohm	R136	1		
953	MAIN BOARD INSERT	FB470623	MOF 1W/M(A) 5% 62Kohm	R143	1		

954	MAIN BOARD INSERT	80002031	FUSEABLE RES 1/2W(A)M 0.22ohm	R150	1		
955	MAIN BOARD INSERT	80002031	FUSEABLE RES 1/2W(A)M 0.22ohm	R175	1		
956	MAIN BOARD INSERT	80011181	FUSEABLE RES 1/2W(A)M 22ohm	R304	1		
957	MAIN BOARD INSERT	FB710150	MOF 3W/M(A) 5% 15ohm	R309	1		
958	MAIN BOARD INSERT	FB560010	MOF 2W/M(A) 5% 1ohm	R311	1	L,S	
959	MAIN BOARD INSERT	FB560129	MOF 2W/M(A) 5% 1.2ohm	R311	1	T	
960	MAIN BOARD INSERT	FB470270	MOF 1W/M(A) 5% 27ohm	R312	1		
961	MAIN BOARD INSERT	FB560331	MOF 2W/M(A) 5% 330ohm	R316	1		
962	MAIN BOARD INSERT	FB560201	MOF 2W/M(A) 5% 200ohm	R335	1		
963	MAIN BOARD INSERT	FB470393	MOF 1W/M(A) 5% 39Kohm	R349	1		
964	MAIN BOARD INSERT	FB560681	MOF 2W/M(A) 5% 680ohm	R376	1		
965	MAIN BOARD INSERT	FB470109	MOF 1W/M(A) 5% 1ohm	R415	1	L,S	
966	MAIN BOARD INSERT	FB470129	MOF 1W/M(A) 5% 1.2ohm	R415	1	T	
967	MAIN BOARD INSERT	FB470109	MOF 1W/M(A) 5% 1ohm	R421	1		
968	MAIN BOARD INSERT	FB470109	MOF 1W/M(A) 5% 1ohm	R422	1		
969	MAIN BOARD INSERT	FB470100	MOF 1W/M(A) 5% 10ohm	R606	1		
970	MAIN BOARD INSERT	80003751	RELAY 12V 6P GSA-SS-212DM(GOOD-SKY)	RL101	1		
971	MAIN BOARD INSERT	80003761	RELAY 12V 6P OSA-SS-212DM5(OEG)	RL101	OR		
972	MAIN BOARD INSERT	80010001	RELAY RUDH-SH-112D 400ohm (GOOD SKY)	RL301	1		
973	MAIN BOARD INSERT	R0224308	BASE PIN 2.36mm P=8/10 4P	S301	1		
974	MAIN BOARD INSERT	R0224125	BASE PIN 2P+HOUSING P=2.5mm	S701	1		
975	MAIN BOARD INSERT	R0224129	BASE PIN 6P+HOUSING P=2.5mm	S702	1		
976	MAIN BOARD INSERT	80011081	CERAMIC SPARK CAPS 1.5KV+-500V	SG301	1		
977	MAIN BOARD INSERT	80009971	SW POWER 30V/0.3A JPS1258(Favortron)	SW101	1		
978	MAIN BOARD INSERT	80010621	WAFER 2Lx3P 2.54mm	SW301	1		
979	MAIN BOARD INSERT	80000251	TACT SW 1P 100G+-50	SW701	1		
980	MAIN BOARD INSERT	80000251	TACT SW 1P 100G+-50	SW702	1		
981	MAIN BOARD INSERT	80000251	TACT SW 1P 100G+-50	SW703	1		
982	MAIN BOARD INSERT	80009981	POWER X'FM ERL35 500uH N0501	T101	1		B Ver.
983	MAIN BOARD INSERT	80010461	17" 70K N0701 FBT	T301	1	L,S	
984	MAIN BOARD INSERT	80010561	17" N0701 TOSHIBA FBT	T301	1	T	
985	MAIN BOARD INSERT	80000281	H.DRIVE X'FM 4.5mH EI-19	T302	1		
986	MAIN BOARD INSERT	80010921	N0701 D.F X'FM EI-19(1:11)	T303	1	L,T	
987	MAIN BOARD INSERT	80010931	N0701 D.F X'FM EI-19(1:6)	T303	1	S	
988	MAIN BOARD INSERT	80000801	THERMISTOR NTCR SCK054 13.3mm	TH101	1		
989	MAIN BOARD INSERT	80005821	THERMISTOR PTCR 4.5ohm	TH102	1		
990	MAIN BOARD INSERT	R0224074	SINGLE PIN L=11.5 D=1.0	TP1	1		
991	MAIN BOARD INSERT	R0224074	SINGLE PIN L=11.5 D=1.0	TP2	1		
992	MAIN BOARD INSERT	R0224077	BASE PIN 1P 1.55mm	TPC	1		
993	MAIN BOARD INSERT	DD002600	IC LINEAR KA3842A 8P	U101	1		
994	MAIN BOARD INSERT	DD002900	IC LINEAR KA3843B 8P	U102	1		
995	MAIN BOARD INSERT	80000321	IC PHOTO COUBLE PS2501 4P	U103	1		
996	MAIN BOARD INSERT	80000321	IC PHOTO COUBLE PS2501 4P	U103	OR		
997	MAIN BOARD INSERT	DD004600	IC LM1290	U301	1		
998	MAIN BOARD INSERT	12800282	HEAT SINK 44*27*50	U401	1		
999	MAIN BOARD INSERT	14000041	SCREW (P-#2CBRITS*3*8*15BF)	U401	1		
1000	MAIN BOARD INSERT	80001041	IC TDA8172 (N.S,SGS)	U401	1		
1001	MAIN BOARD INSERT	80000351	IC LM1295	U402	1		
1002	MAIN BOARD INSERT	80011501	N0701 VE MASK MCU	U701	1		
1003	MAIN BOARD INSERT	80011491	N0701 VE MTP WT6016 V3	U701	OR		
1004	MAIN BOARD INSERT	BE028000	IC AT24C04 (ATMEL,ST)	U702	1		
1005	MAIN BOARD INSERT	80008701	IC KS24C041C(SAMSUNG)	U702	OR		
1006	MAIN BOARD INSERT	FF300201	VR CARBON 6mm 200 ohm/B	VR101	1		

1007	MAIN BOARD INSERT	FF310102	VR CARBON 6mm 1K	VR102	1		
1008	MAIN BOARD INSERT	FF310503	VR CARBON 6mm 50Kohm M	VR301	1	L,S	
1009	MAIN BOARD INSERT	FF300103	VR CARBON 6mm 10K VZ067TH1	VR306	1		
1010	MAIN BOARD INSERT	FF310204	VR CARBON 6mm 200K	VR307	1	T	
1011	MAIN BOARD INSERT	80010021	N9701 VE WIRE ASSY	WIRE ASSY	1		
1012	MAIN BOARD INSERT	EM08003	X'TAL 49U 8MHz	X701	1		
1013	MAIN BOARD INSERT	18000321	EDGE SADDLE(SB-31)		1		
1014	PACKING	80001651	POWER CORD 3P 1.8M EUROPE NON-SHIELD	CORD POWER	1		B
1015	PACKING	11000331	REVOLVING STAND ASSY		1		
1016	PACKING	13400491	POLYON(R) CARTON		1		
1017	PACKING	13400501	POLYON(L) CARTON		1		
1018	PACKING	13700021	BAG POLYETHYLENE (270*370)		1		
1019	PACKING	13700031	BAG POLYETHYLENE (150*370)		1		
1020	PACKING	13700071	PE BAG (500*480*850 + WARNING)		1		
1021	PACKING	13700091	BAG POLYETHYLENE (360*360)		1		
1022	PACKING	13200851	CARTON BOX V720-1(B)		1		B
1023	PACKING	15500621	OWNERS MANUAL V520/V720-1(B ver.)		1		B
1024	PACKING	15500751	OWNERS MANUAL V520/V720-1(C ver.)		1		C
1025	PACKING	15200331	LABEL, SERIAL BARCODE		1		
1026	PACKING	15200251	LABEL (D8,MAGENTA)		1		C
1027	PACKING	13201211	CARTON BOX V720-1(C)		1		C
1028	PACKING	15900051	SALES OFFICE LIST		1		
1029	PACKING	11000381	REVOLVING STAND ASSY			OR	
1030	PACKING	11000382	REVOLVING STAND ASSY			OR	
1031	PACKING	80001661	POWER CORD 3P 1.8M CHINA NON- SHIELD COLOR SG 8508(CT0A6)	CORD POWER	1		C
1032	REVOLVING STAND ASSY	17000291	CUSHION SHEET	FOR BASE	4		
1033	REVOLVING STAND ASSY	17000451	CUSHION SHEET	FOR BASE	4		
1034	REVOLVING STAND ASSY	11000251	REVOLVING STAND(B)(94HB)		1		
1035	REVOLVING STAND ASSY	11000261	REVOLVING STAND(T)(94HB)		1		
1036	REVOLVING STAND ASSY	11000262	REVOLVING STAND(T)(94HB)		1		
1037	REVOLVING STAND ASSY	11000361	REVOLVING STAND(B)(94HB)		1		
1038	REVOLVING STAND ASSY	11000362	REVOLVING STAND(B)(94HB)		1		
1039	SET ASSY	80009271	SIGNAL CABLE 20276 1.5M FOR N9701 VE	CABLE	1		
1040	SET ASSY	80004531	LG M41LFQ803X13(LA)	CRT	1	L	
1041	SET ASSY	80004551	SAMSUNG M41QAR361X101(A)	CRT	1	S	
1042	SET ASSY	80009321	TOSHIBA M41LRT128X401(F4)	CRT	1	T	
1043	SET ASSY	80010511	17" N0701 MPRII DEGAUSSING	DEGAUSSING COIL	1		
1044	SET ASSY	14000011	SCREW (#2CBRITS*4*16*15BF)	FOR BACK	2		
1045	SET ASSY	14000071	SCREW (PL-CPTS*3*8*15BF)	FOR BKT-CAB	2		
1046	SET ASSY	14300031	SCREW (PL-CPIMS*4*10*15BF)	FOR BKT-CAB	2		
1047	SET ASSY	14000041	SCREW (P-#2CBRITS*3*8*15BF)	FOR BKT-PCB	2		
1048	SET ASSY	14600011	SCREW SPECIAL (5*25)	FOR CRT	4		
1049	SET ASSY	17000111	CRT PAD t=3.5	FOR CRT	4		
1050	SET ASSY	18000281	LOOKING CABLE CLIP(GL-70A)	FOR DEGUES	2		
1051	SET ASSY	18000371	FIXED CABLE CLIP (GL-115A)	FOR DEGUES	2		
1052	SET ASSY	11700211	SUPPORT	FOR FRONT	2		
1053	SET ASSY	14000021	SCREW (#2CBRITS*4*12*15BF)	FOR FRONT	4		
1054	SET ASSY	18000271	SPACER SUPPROT(PS-26GD)	FOR M/B	4		
1055	SET ASSY	80000031	GND WIRE 18AWG L=130mm	GND WIRE	1		
1056	SET ASSY	80000891	WIRE L=360mm BLACK AWG18	GND WIRE	1		
1057	SET ASSY	80001931	17" ROTATION COIL	GND WIRE	1		
1058	SET ASSY	80010951	MS75 CRT GND WIRE	GND WIRE	1		
1059	SET ASSY	R0191207	TAPE BLACK L=75mmX3	TAPE	0.015		

1060	SET ASSY	17000321	CABLE TIES(GT-100M)	TIE	10		
1061	SET ASSY	10100572	CABINET FRONT ASSY		1		
1062	SET ASSY	10100594	CABINET BACK		1		
1063	SET ASSY	12000281	BRACKET(PCB)		1		
1064	SET ASSY	15200471	LABEL WARNING (27.5KV/600uA)		1		
1065	SET ASSY	12000551	BRACKET(CABLE)		1		
1066	SET ASSY	12300202	PLATE SHIELDING (VIDEO)		1		
1067	SET ASSY	15000841	NAME PLATE INSTRUCTION V720-1(B)		1		B
1068	SET ASSY	15000991	NAME PLATE INSTRUCTION V720-1(C)		1		C
1069	SET ASSY	15200031	LABEL(REV.)		1		
1070	SET ASSY	17000301	CUSHION PIECE (BACK)		1		
1071	SET ASSY	18000311	PCB SUPPORT (SS-8)		1		
1072	SET ASSY	18000421	SWITCH EXPANDING COVER		1		
1073	SET ASSY	18000261	ANODE CLAMPER(SPA-11G)		2		

REVISED BY ECN NO: NN1020002

SORT BY ASSY CODE



## 2) MultiSync V721 Different List

B: Asia, R: Australia, L: LG, T: Toshiba, S: Samsung

	ASSY CODE	PART NO	DESCRIPTION	LOCATION	Q'TY	ALT	REMARK
1	CABINET FRONT ASSY	10101111	CABINET FRONT(PC+ABS)		1		
2	CABINET FRONT ASSY	11300351	PUSH BUTTON (CONTROL A)		1		
3	CABINET FRONT ASSY	11300781	PUSH BUTTON (SW)		1		
4	CABINET FRONT ASSY	11600181	LENS		1		
5	CABINET FRONT ASSY	13000061	COIL SPRING		1		
6	PACKING ASSY	80002931	POWER CORD 3P 1.8M AUSTRALIA NON-SHIELD COLOR SG 8508	CORD POWER	1		R
7	PACKING ASSY	80001651	POWER CORD 3P 1.8M EUROPE N-SHIELD COLOR SG8508	CORD POWER	1		B
8	PACKING ASSY	13400491	POLYON(R) CARTON		1		
9	PACKING ASSY	13400501	POLYON(L) CARTON		1		
10	PACKING ASSY	13700021	BAG POLYETHYLENE (270*370)		1		
11	PACKING ASSY	13700031	BAG POLYETHYLENE (150*370)		1		
12	PACKING ASSY	13700071	PE BAG (500*480*850 + WARNING)		1		
13	PACKING ASSY	13700091	BAG POLYETHYLENE (360*360)		1		
14	PACKING ASSY	13201121	CARTON BOX V721(R)-1		1		R
15	PACKING ASSY	15500701	OWNERS MANUAL V721/V921(R)		1		R
16	PACKING ASSY	13201221	CARTON BOX V721(B)-1		1		B
17	PACKING ASSY	15500771	OWNERS MANUAL V521/V721/V921		1		B
18	PACKING ASSY	19700041	INSTRUCTION CD-ROM V521/V721/V921		1		B
19	PACKING ASSY	15900051	SALES OFFICE LIST		1		B
20	PACKING ASSY	15700043	WARRANTY CARD(AUST)		1		R
21	PACKING ASSY	15200241	LABEL (D8,CYAN)		1		R
22	PACKING ASSY	11000331	REVOLVING STAND ASSY		1		
23	PACKING ASSY	11000381	REVOLVING STAND ASSY		OR		
24	PACKING ASSY	11000382	REVOLVING STAND ASSY		OR		
25	REVOLVING STAND ASSY	17000291	CUSHION SHEET	FOR BASE	4		
26	REVOLVING STAND ASSY	17000451	CUSHION SHEET	FOR BASE	4		
27	REVOLVING STAND ASSY	11000251	REVOLVING STAND(B)(94HB)		1		
28	REVOLVING STAND ASSY	11000261	REVOLVING STAND(T)(94HB)		1		
29	REVOLVING STAND ASSY	11000262	REVOLVING STAND(T)(94HB)		1		
30	REVOLVING STAND ASSY	11000361	REVOLVING STAND(B)(94HB)		1		
31	REVOLVING STAND ASSY	11000362	REVOLVING STAND(B)(94HB)		1		
32	SET ASSY	80009271	SIGNAL CABLE 20276 1.5M FOR N9701 VE	CABLE	1		
33	SET ASSY	80005581	17"LG M41LFQ803X13(LA)	CRT	1	L	R
34	SET ASSY	80004531	LG M41LFQ803X13(LA)	CRT	1	L	B
35	SET ASSY	80004551	SAMSUNG M41QAR361X101(A)	CRT	1	S	
36	SET ASSY	80009321	TOSHIBA M41LRT128X401(FA)	CRT	1	T	
37	SET ASSY	80010521	17" N0701 TCO DEGAUSSING SAMSUNG CRT	DEGAUSSING COIL	1	S	
38	SET ASSY	80010531	17" N0701 TCO DEGAUSSING LG CRT	DEGAUSSING COIL	1	L	
39	SET ASSY	80010501	17" N0701 TCO DEGAUSSING TOSHIBA CRT	DEGAUSSING COIL	1	T	
40	SET ASSY	14000011	SCREW (#2CBRITS*4*16*15BF)	FOR BACK	2		
41	SET ASSY	14000071	SCREW (PL-CPTS3*8*15BF)	FOR BKT-CAB	2		
42	SET ASSY	14300031	SCREW (PL-CPIMS*4*10*15BF)	FOR BKT-CAB	2		
43	SET ASSY	14000031	SCREW (#2CBRTS*3*12*15BF)	FOR BKT-PCB	2		
44	SET ASSY	17000252	COPPER SHIELDING	FOR CRT	1		
45	SET ASSY	14600011	SCREW SPECIAL (5*25)	FOR CRT	4		
46	SET ASSY	17000111	CRT PAD t=3.5	FOR CRT	4		
47	SET ASSY	17000261	AL TAPE 40*130mm	FOR CRT	4		
48	SET ASSY	18000281	FIXED CABLE CLIP(GL-70A)	FOR DEGUES	2		
49	SET ASSY	18000371	FIXED CABLE CLIP(GL-115A)	FOR DEGUES	2		
50	SET ASSY	11700221	SUPPORT(PC+ABS)	FOR FRONT	2		
51	SET ASSY	14000021	SCREW (#2CBRITS*4*12*15BF)	FOR FRONT	4		
52	SET ASSY	18000271	SPACER SUPPROT(PS-26GD)	FOR M/B	4		

53	SET ASSY	80000031	GND WIRE 18AWG L=130mm	GND WIRE	1		
54	SET ASSY	80000891	WIRE L=360mm BLACK AWG18	GND WIRE	1		
55	SET ASSY	80001931	17" ROTATION COIL	GND WIRE	1		
56	SET ASSY	80010951	MS75 CRT GND WIRE	GND WIRE	1		
57	SET ASSY	72000641	TCO PCB	PCB TCO	1		
58	SET ASSY	80005101	WIRE 1618 24AWG 40mm BK	SHIELD WIRE	1		
59	SET ASSY	R0191207	TAPE BLACK L=75mmX3	TAPE	0.015		
60	SET ASSY	80011271	WIRE 1618 24AWG 970mm GRAY(LG)	TCO WIRE	1	L	
61	SET ASSY	80011601	WIRE 1618 24AWG 790mm GRAY (T)	TCO WIRE	1	T	
62	SET ASSY	80011261	WIRE 1618 24AWG 890mm GRAY(SAMSUNG)	TCO WIRE	1	S	
63	SET ASSY	17000321	CABLE TIES(GT-100M)	TIE	10		
64	SET ASSY	15200031	LABEL (REV.)		1		
65	SET ASSY	15000981	NAME PLATE INSTRUCTION V721(R)		1		
66	SET ASSY	15200471	LABEL WARNING (27.5KV/600uA)		1		
67	SET ASSY	15200331	LABEL,SERIAL BARCODE		1		
68	SET ASSY	15200681	LABEL TCO99 (FOR CABINET)		1		
69	SET ASSY	15200201	LABEL (EMC) (V500R)		1		R
70	SET ASSY	10100924	CABINET BACK		1		
71	SET ASSY	10101101	CABINET FRONT ASSY(PC+ABS)		1		
72	SET ASSY	12000281	BRACKET(PCB)		1		
73	SET ASSY	12000551	BRACKET(CABLE)		1		
74	SET ASSY	12300202	PLATE SHIELDING (VIDEO)		1		
75	SET ASSY	17000301	CUSHION PIECE (BACK)		1		
76	SET ASSY	18000311	PCB SUPPORT (SS-8)		1		
77	SET ASSY	18000421	SWITCH EXPANDING COVER		1		
78	SET ASSY	18000261	ANODE CLAMPER(SPA-11G)		2		
79	SET ASSY	18000361	HOLDER PCB FOR TCO(CBS-5C)		3		

REVISED BY ECN NO: NN1060006

SORT BY ASSY CODE

### 3) Diamond Scan Different List

	ASSY CODE	PART NO	DESCRIPTION	LOCATION	Q'TY	ALT	REMARK
1	CABINET FRONT ASSY	10100741	CABINET FRONT(PC+ABS)		1		
2	CABINET FRONT ASSY	11300481	PUSH BUTTON (CONTROL)		1		
3	CABINET FRONT ASSY	11300491	PUSH BUTTON (SW)		1		
4	CABINET FRONT ASSY	11600181	LENS		1		
5	CABINET FRONT ASSY	13000061	COIL SPRING		1		
6	PACKING ASSY	80001651	POWER CORD 3P 1.8M EUROPE N-SHIELD COLOR SG8508	POWER CORD	1		
7	PACKING ASSY	13201011	CARTON BOX DS71(B)		1		
8	PACKING ASSY	15500731	OWNERS MANUAL DS71(B)		1		
9	PACKING ASSY	15200331	LABEL,SERIAL BARCODE		1		
10	PACKING ASSY	11000331	REVOLVING STAND ASSY		1		
11	PACKING ASSY	13400491	POLYON(R) CARTON		1		
12	PACKING ASSY	13400501	POLYON(L) CARTON		1		
13	PACKING ASSY	13700021	BAG POLYETHYLENE (270*370)		1		
14	PACKING ASSY	13700031	BAG POLYETHYLENE (150*370)		1		
15	PACKING ASSY	13700071	PE BAG (500*480*850 + WARNING)		1		
16	PACKING ASSY	13700091	BAG POLYETHYLENE (360*360)		1		
17	PACKING ASSY	11000381	REVOLVING STAND ASSY		OR		
18	PACKING ASSY	11000382	REVOLVING STAND ASSY		OR		
19	REVOLVING STAND ASSY	17000291	CUSHION SHEET	FOR BASE	4		
20	REVOLVING STAND ASSY	17000451	CUSHION SHEET	FOR BASE	4		
21	REVOLVING STAND ASSY	11000361	REVOLVING STAND(B)(94HB)		1		
22	REVOLVING STAND ASSY	11000251	REVOLVING STAND(B)(94HB)		1		
23	REVOLVING STAND ASSY	11000261	REVOLVING STAND(T)(94HB)		1		
24	REVOLVING STAND ASSY	11000362	REVOLVING STAND(B)(94HB)		1		
25	REVOLVING STAND ASSY	11000262	REVOLVING STAND(T)(94HB)		1		
26	SET ASSY	80009271	SIGNAL CABLE 20276 1.5M FOR N9701 VE	CABLE	1		
27	SET ASSY	80004471	TOSHIBA M41LRK107X404(XF4)	CRT	1		
28	SET ASSY	80011201	17" N0701 TCO DEGAUSSING TOSHIBA CRT	DEGAUSSING COIL	1		
29	SET ASSY	14000011	SCREW (#2CBRITS*4*16*15BF)	FOR BACK	2		
30	SET ASSY	14000071	SCREW (PL-CPTS3*8*15BF)	FOR BKT-CAB	2		
31	SET ASSY	14300031	SCREW (PL-CPIMS*4*10*15BF)	FOR BKT-CAB	2		
32	SET ASSY	14000031	SCREW (#2CBRTS*3*12*15BF)	FOR BKT-PCB	2		
33	SET ASSY	17000371	COPPER SHIELDING (V500/V700)	FOR CRT	1		
34	SET ASSY	14600011	SCREW SPECIAL (5*25)	FOR CRT	4		
35	SET ASSY	17000111	CRT PAD t=3.5	FOR CRT	4		
36	SET ASSY	17000261	AL TAPE 40*130mm	FOR CRT	4		
37	SET ASSY	18000281	FIXED CABLE CLIP(GL-70A)	FOR DEGUES	2		
38	SET ASSY	18000371	FIXED CABLE CLIP(GL-115A)	FOR DEGUES	2		
39	SET ASSY	11700221	SUPPORT(PC+ABS)	FOR FRONT	2		
40	SET ASSY	14000021	SCREW (#2CBRITS*4*12*15BF)	FOR FRONT	4		
41	SET ASSY	18000271	SPACER SUPPROT(PS-26GD)	FOR M/B	4		
42	SET ASSY	80000031	GND WIRE 18AWG L=130mm	GND WIRE	1		
43	SET ASSY	80000891	WIRE L=360mm BLACK AWG18	GND WIRE	1		
44	SET ASSY	80001931	17" ROTATION COIL	GND WIRE	1		
45	SET ASSY	80010951	MS75 CRT GND WIRE	GND WIRE	1		
46	SET ASSY	72000641	TCO PCB	PCB TCO	1		
47	SET ASSY	80005101	WIRE 1618 24AWG 40mm BK	SHIELD WIRE	1		
48	SET ASSY	R0191207	TAPE BLACK L=75mmX3	TAPE	0.015		
49	SET ASSY	80011271	WIRE 1618 24AWG 970mm GRAY(LG)	TCO WIRE	1		
50	SET ASSY	17000321	CABLE TIES(GT-100M)	TIE	10		
51	SET ASSY	10100731	CABINET FRONT ASSY(PC+ABS)		1		
52	SET ASSY	10100924	CABINET BACK		1		

53	SET ASSY	15200031	LABEL (REV.)		1		
54	SET ASSY	15000951	NAME PLATE INSTRUCTION DS71(B)		1		
55	SET ASSY	15200471	LABEL WARNING (27.5KV/600uA)		1		
56	SET ASSY	12000281	BRACKET(PCB)		1		
57	SET ASSY	12000551	BRACKET(CABLE)		1		
58	SET ASSY	12300202	PLATE SHIELDING (VIDEO)		1		
59	SET ASSY	17000301	CUSHION PIECE (BACK)		1		
60	SET ASSY	18000311	PCB SUPPORT (SS-8)		1		
61	SET ASSY	18000421	SWITCH EXPANDING COVER		1		
62	SET ASSY	18000261	ANODE CLAMPER(SPA-11G)		2		
63	SET ASSY	18000361	HOLDER PCB FOR TCO(CBS-5C)		3		

REVISED BY ECN NO: NN1050002

SORT BY ASSY CODE

# N0701 (V720/V721/DS71)

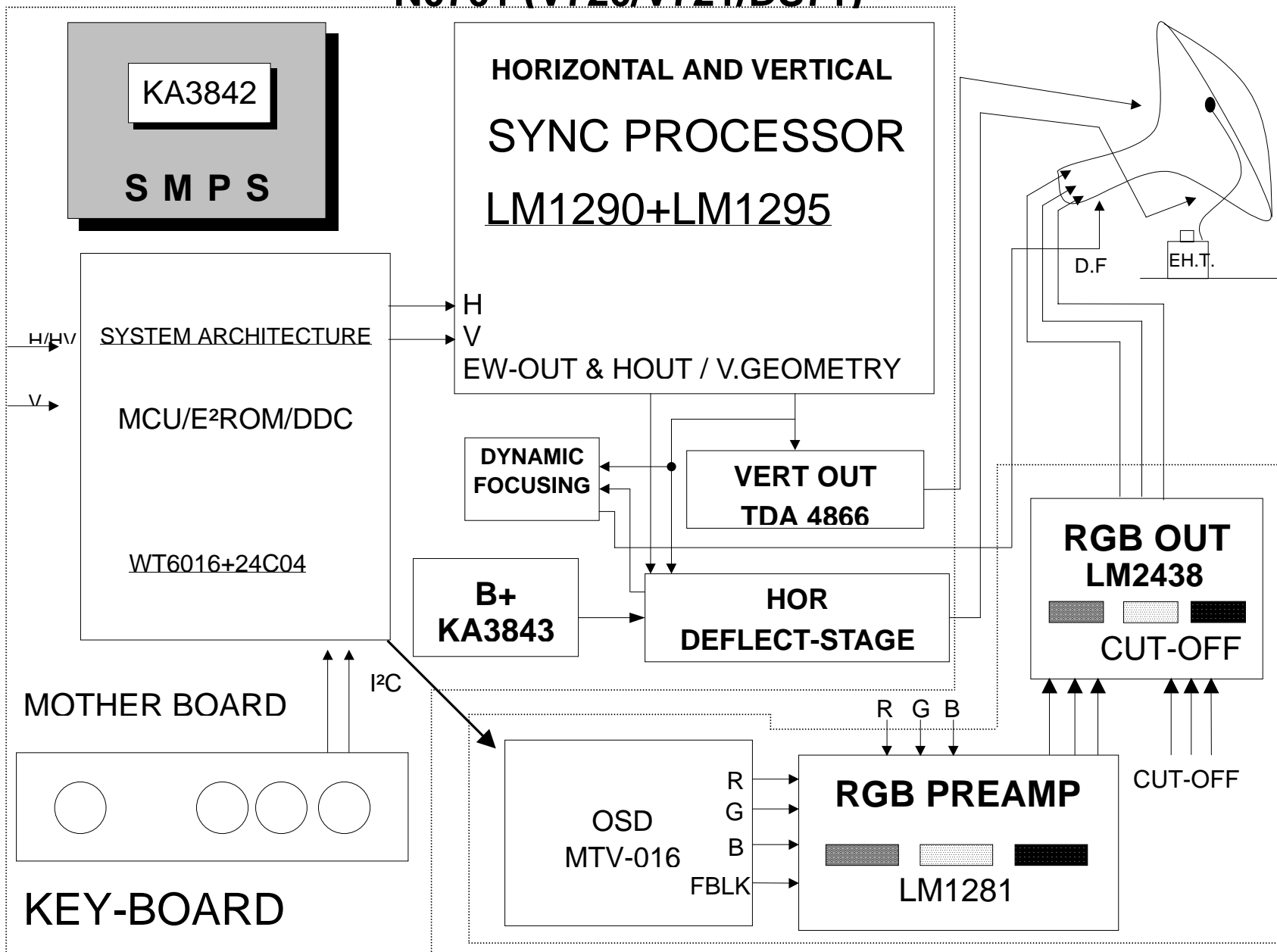

BLOCK DIAGRAM

# SCHEMATIC DIAGRAMS

## 1) Video Board

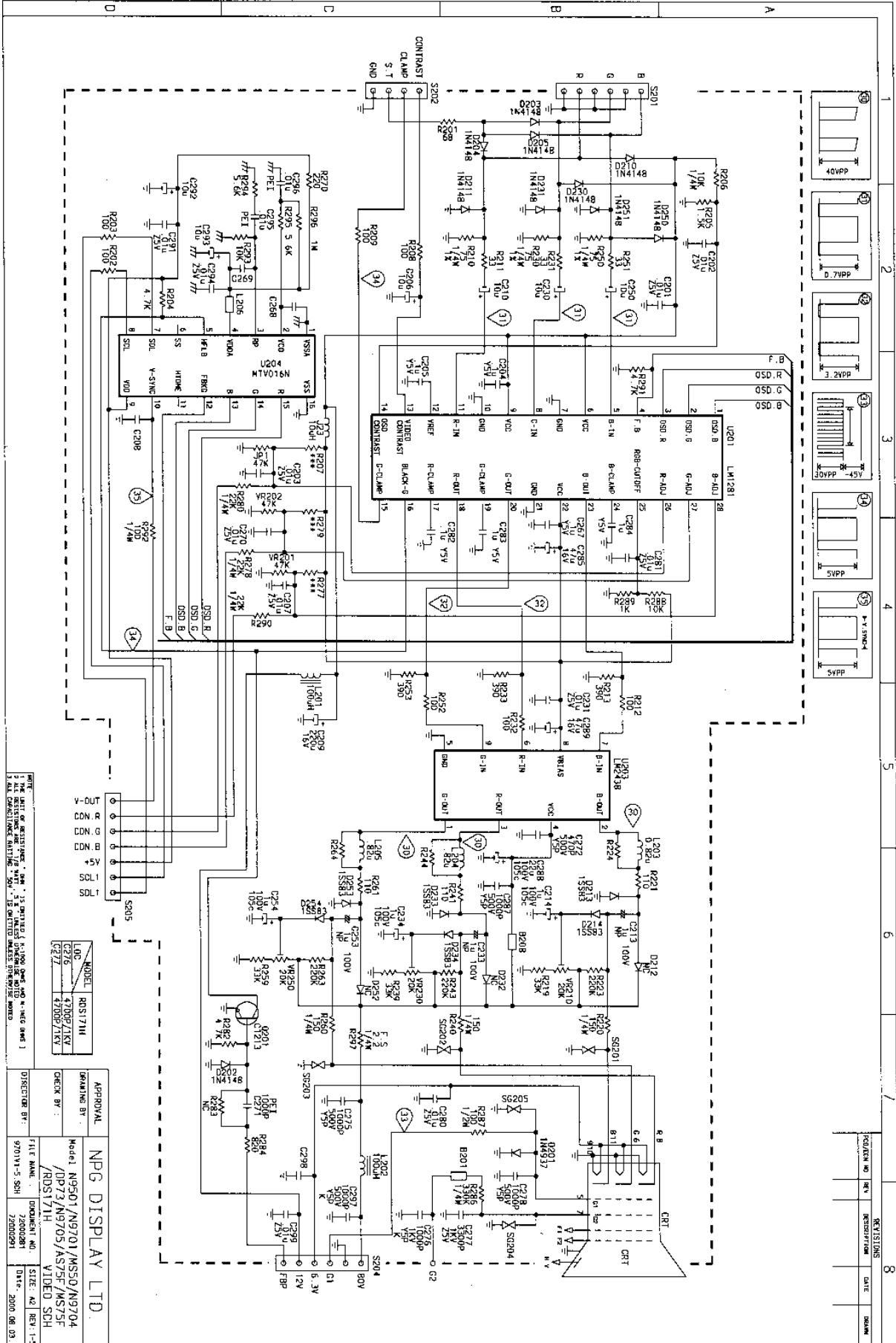

APPROVAL	Model: NP9501 / NP9701 / NSSD / NP704
DRAWING BY:	Model: NP9501 / NP9701 / NSSD / NP704
CHECK BY:	Model: NP9501 / NP9701 / NSSD / NP704
FILE NAME:	Model: NP9501 / NP9701 / NSSD / NP704
DOCUMENT NO.:	Model: NP9501 / NP9701 / NSSD / NP704
DATE:	Model: NP9501 / NP9701 / NSSD / NP704

REVISIONS	
NO.	DESCRIPTION

2) Main Board

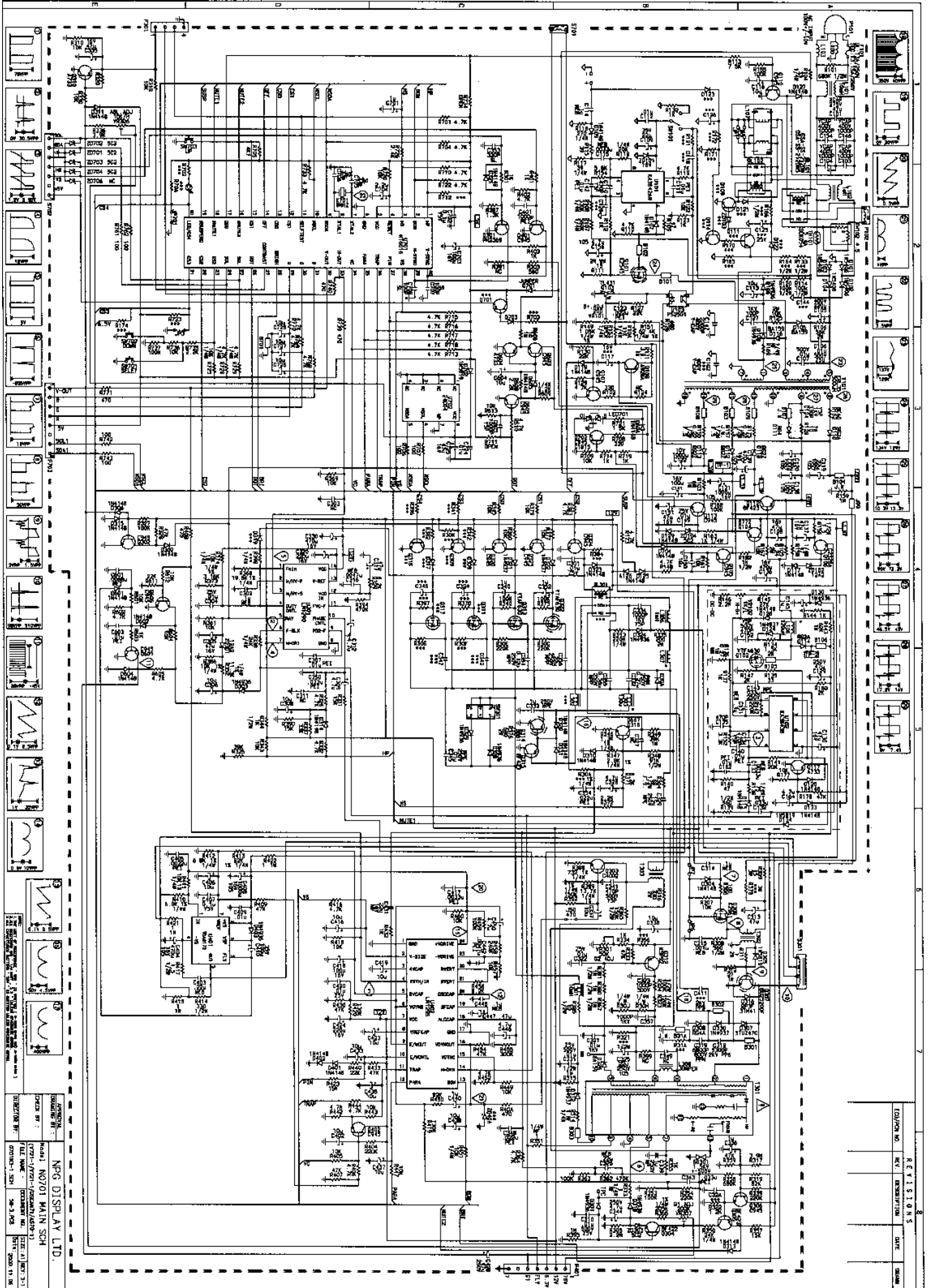

MODEL NO.	NP6 DISPLAY LTD.
DESIGN NO.	NP6 DISPLAY LTD.
DATE	2000.11.16
FILE NAME	NP6 MAIN SCH
DESIGNER	NP6 DISPLAY LTD.
DATE	2000.11.16

REVISIONS		
NO.	REVISION	DATE