

# Panasonic Service and Technology Company

## Technical Guide

TC-32LX70/700, TC37LZ85, and TC-32LX85 LCD Display Television



National Training

**Prepared by**  
**Jean Magloire**  
Panasonic Service and Technology Company  
**National Training**

Copyright © 2008 by Panasonic Services Company  
All rights reserved. Unauthorized copying and distribution is a violation of law.

**Warning**

This service information is designed for experienced repair technicians only and is not designed for use by the general public. It does not contain warnings or cautions to advise non-technical individuals of potential dangers in attempting to service a product. Products powered by electricity should be serviced or repaired only by experienced professional technicians. Any attempt to service or repair the product or products dealt with in this service information by anyone else could result in serious injury or death.

# Table of Contents

Subject	Page #	Subject	Page #
Topics	5	Self-Check Menu	38
2007 LCD TV Specifications	7	Check Point	39
P.C.B Layout (LX700)	8	Serviceman Mode	40
P.C.B Layout (LX70)	9	Serviceman Mode Menu and Navigation	41
P.C.B Layout (LX700 Pictorial)	10	Adjustment Data	42
P.C.B Layout (LX700 Connectors)	11	SRV-TOOL	43
P.C.B Layout (LX700 LVDS Connector)	12	Voltage chart of AP-board	45
TC-32LX700 Board Description	13	Voltage chart of P and A boards	46
P Board – Main Power Board	15	Voltage chart of DT board	47
Main MPU (Power On Commands)	17	Troubleshooting Signal Problems	49
Standby Operation	19	Picture NG and Sound OK (LX700/LX70 )	50
SUB Voltages and Over-voltage Protection	21	Picture OK and Sound NG (LX700/LX70)	51
Main Voltages and Over-voltage Protection	22	Picture NG and Sound NG (LX700/LX70 )	52
Inverter_On Command and Protection	23	No Picture from TV Reception	53
Video Process Block Diagram	25	No Picture	54
Audio Process Block Diagram	27	No Video, Dark Blue Screen	55
MPU SOS Inputs and Blink Codes	29	No Audio	57
Over-Current Protection Circuit	31	No Power	58
Over-Current Protection Circuit 2	33	Power LED Blinks One Time (INV_SOS)	60
Power LED Timing Table	35	Power LED Blinks Three Times (TV_SOS)	61
Self-Check and Reset Function	37	Power LED Blinks Four Times	62

# Table of Contents

2008 LCD Television Models	63
Full HD TC-LZ85 & HD TC-LX85 Series	64
Chassis structure (37 Full HD type)	65
Chassis structure (37 HD type)	66
Signal Circuit Block Diagram	67
TC-32LX85 / TC37LZ85 Signal Circuit Block Diagram	68
TC37LZ85 Signal Circuit Block Diagram	69
TC32LX85 Signal Circuit Block Diagram	71
TC37LZ85 Audio Circuit Block Diagram	73
TC32LX85 Audio Circuit Block Diagram	75
Power Supply Overview	77
Power Supply Description	78
Self-Check and Reset Function	80
SOS and Power LED Indication	81
Power LED Blinks 1 Time	82
Power LED Blinks 3 Times	83
Power LED Blinks 4 or 5 Times	84

Power LED Blinks 6 or 7 Times	85
Power LED Blinks 8 or 9 Times	86
Power LED Blinks 1 Time (TC-32LX85)	87
Power LED Blinks 3 Times (TC-32LX85)	88
Power LED Blinks 4 or 5 Times (TC-32LX85)	89
Power LED Blinks 6 or 7 Times (TC-32LX85)	90
Power LED Blinks 8 or 9 Times (TC-32LX85)	91
Picture Defect)	92
Sound Defect	104
Service Information for 2008 models	105
Internal Pattern generator	106
Copy from the TV to the SD Card	109
Copy Data from the SD Card to the TV	115
Copy Self Check Data to the SD Card	117
Local maintenance	120
Picture Refresh Mode	128



1. Models Comparison
2. Boards Layout
3. Power supply/Standby/Power on
4. Troubleshooting
5. SOS Circuit
6. Video/Audio Processing Circuit
7. Panel Drive Circuit
8. Service Man Mode
9. Self-Check
10. Reset
11. Adjustments
12. Service Information for 2008 models

Purposely left blank

# 2007 LCD TV Specifications

	TC-32LX700	TC-32LX70
<b>VIDEO</b>		
Screen Size Diagonal (inches)	32	32
Aspect Ratio	16:9	16:9
Number of Pixels	1,049,088 (1,366 x 768)	1,049,088 (1,366 x 768)
Brightness (Panel Luminance)	500 cd/m2	500 cd/m2
Display Capability (1080p, 1080i, 720p, 480P)	Y	Y
Motion Picture Pro	Y	—
<b>AUDIO</b>		
Speakers	Slim squawker x 2, woofer x 2 (L, R)	Full-range x 2 (L, R)
Audio Output	20 W (10% THD)	20 W (10% THD)
<b>JACKS</b>		
Integrated ATSC Tuner	Y	Y
SD Memory Card Slot	Y (SDHC Compatible)	—
HDMI Input	2	2
Composite Video Input	3 (1 side)	3 (1 side)
S-Video Input	2	2
Component Video Input (Y, P <sub>B</sub> , P <sub>R</sub> )	1	1
Monitor Output	1	1
Digital Audio Output	1	1
Headphone Jack	1	1

## 32/26LX600

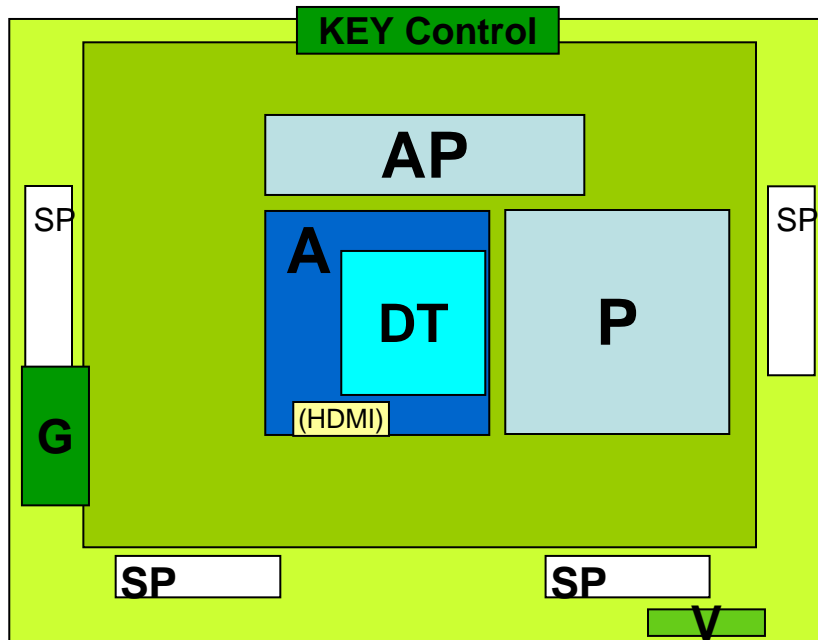

## 32LX700

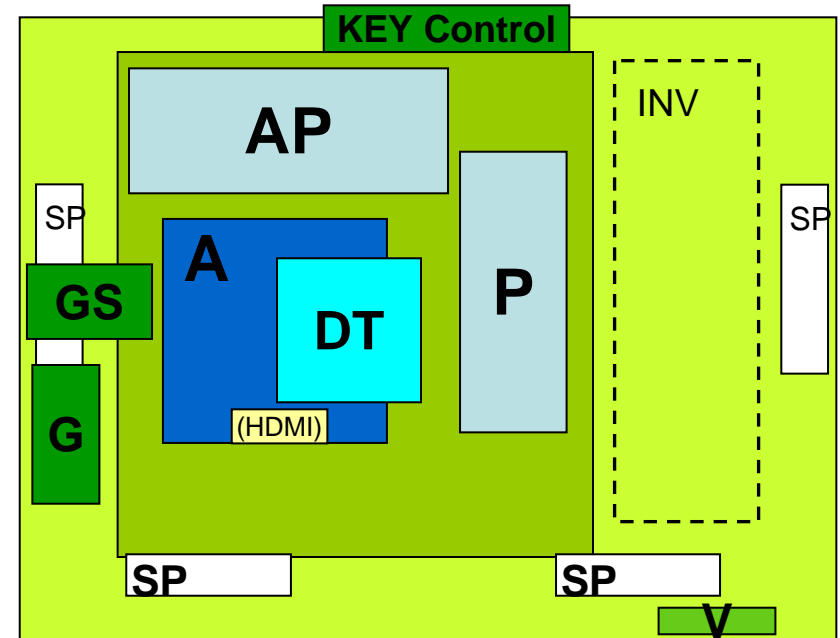

### Differences from LX600:

- GS board for SD card slot is added.
- The inverter PCB of the LX700 is visible.

## 32/26LX60

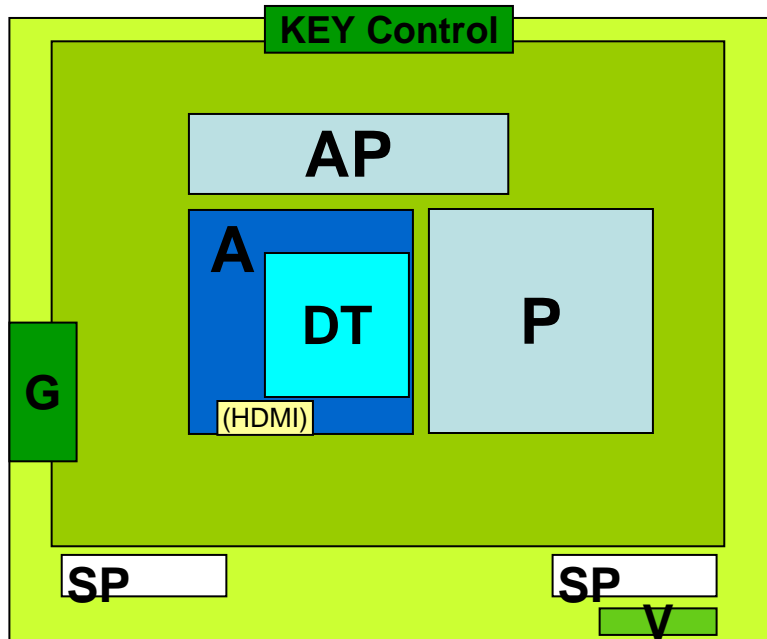

## 32/26LX70

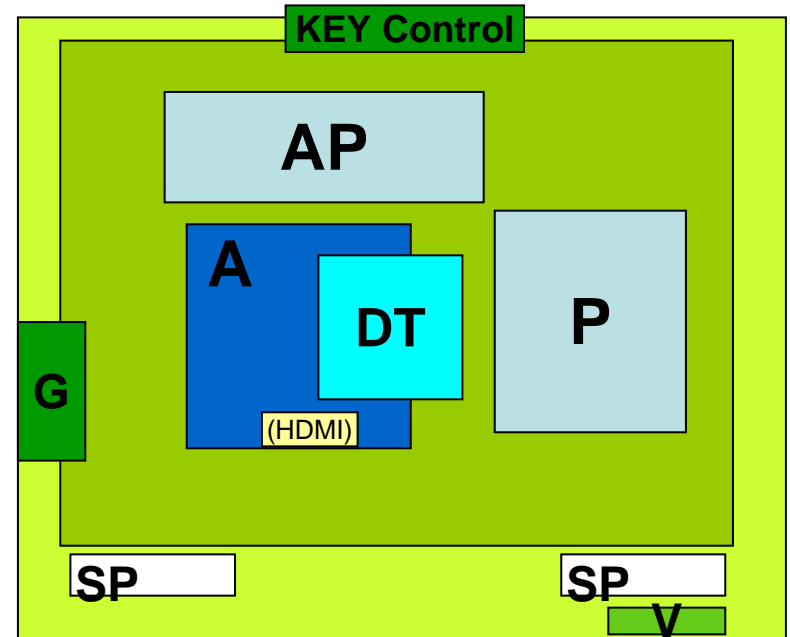

### Differences from LX60:

Board structure is almost same.

# P.C.B Layout (LX700 Pictorial)

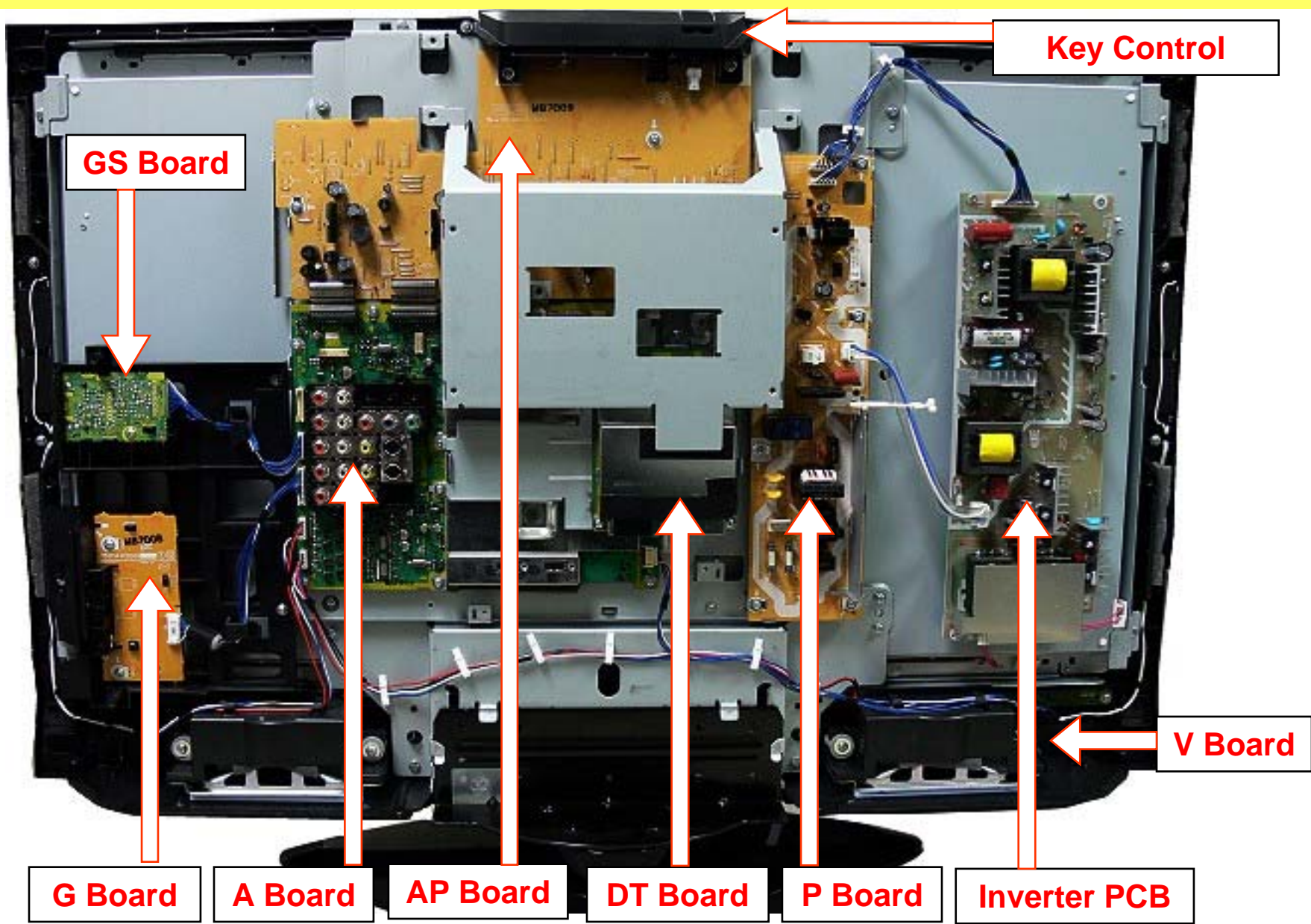

# P.C.B Layout (LX700 Connectors)

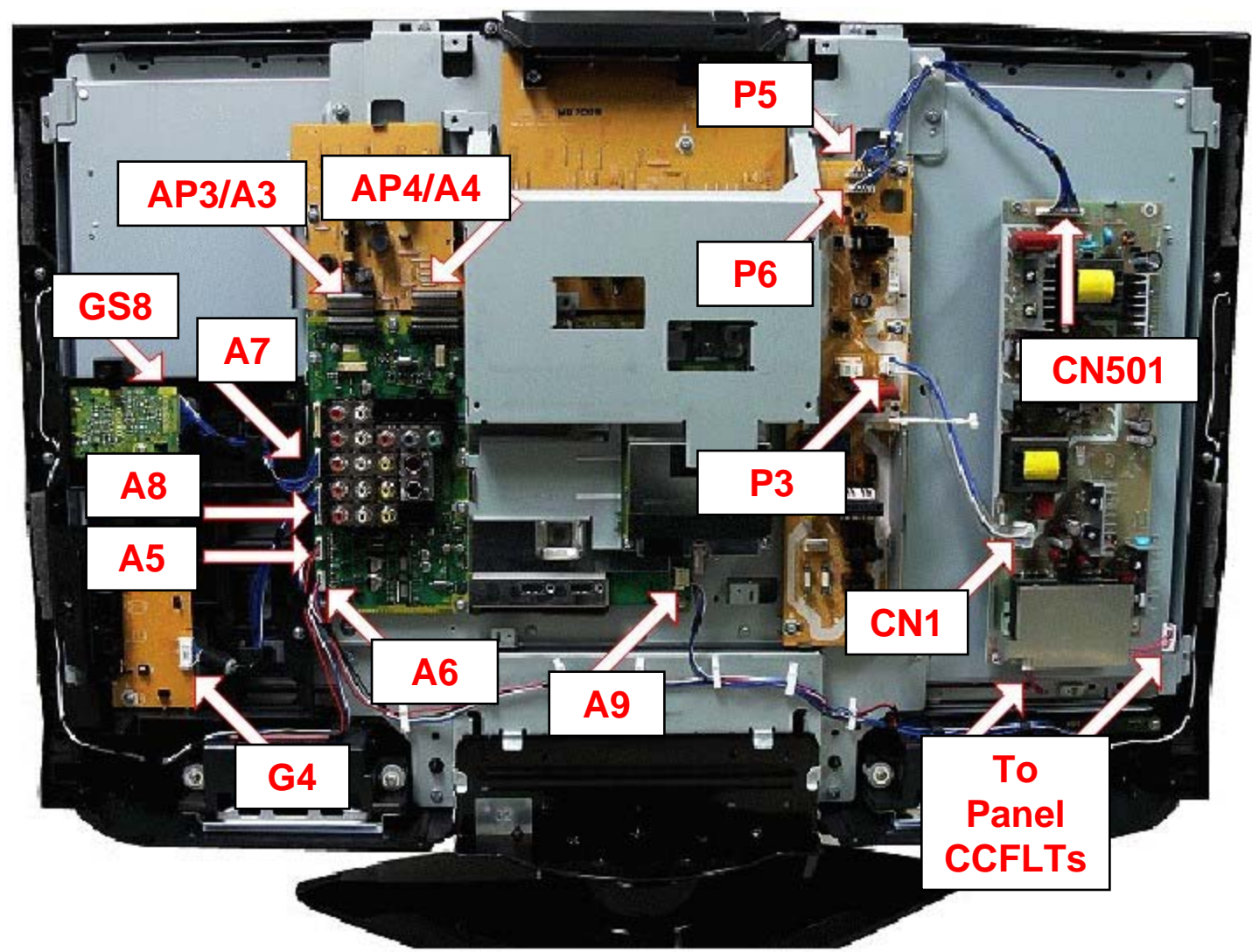



# P.C.B Layout (LX700 LVDS Connector)

Remove the 4 Screws and the metal plate to expose the LVDS Connector.

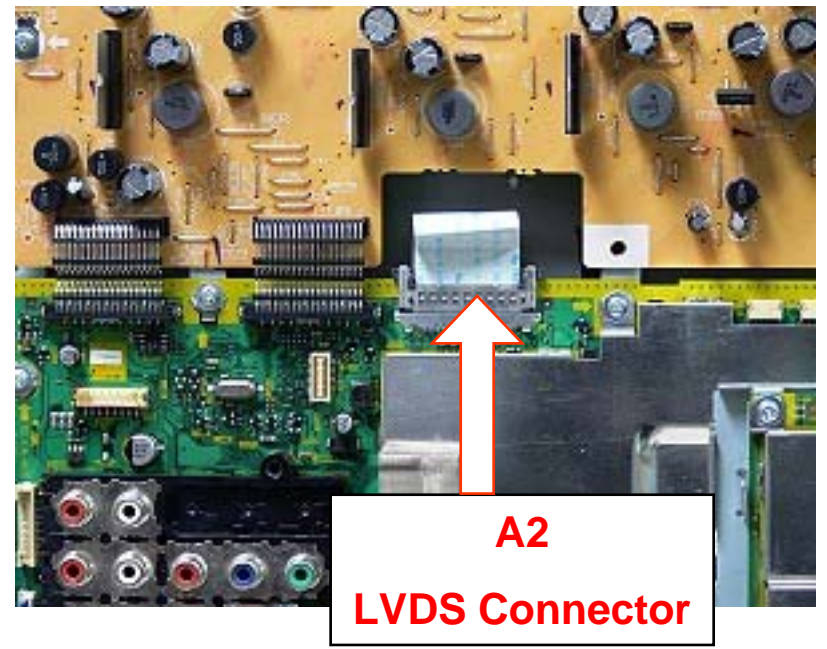
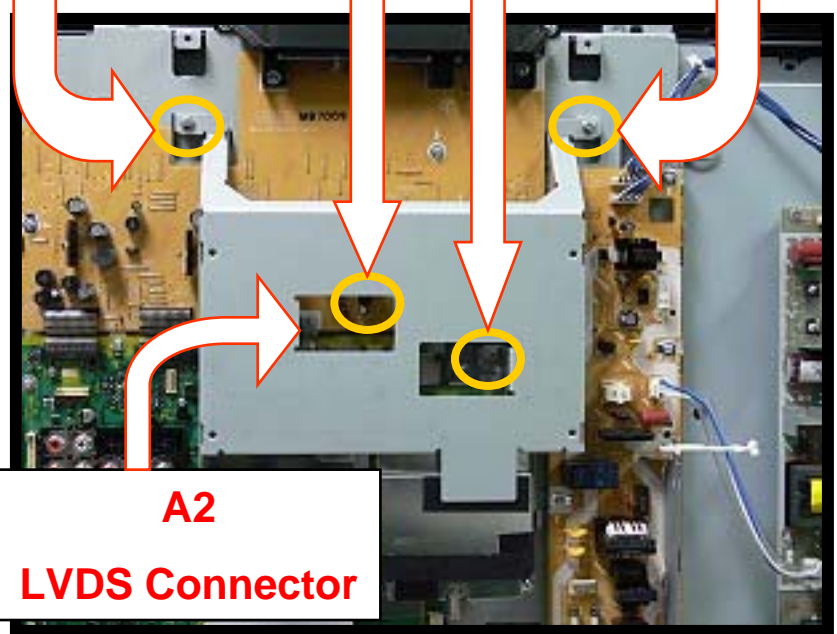



# TC-32LX700 Board Description

<b>Board</b>	<b>Description</b>	<b>Part Number</b>
A-Board	Main (Rear Terminal, AV Switch, MCU, Audio & Video Processor, LVDS) (Exchange Only)	TNPH0683S
AP-Board	DC-DC, Power Switch	TNPA4155ABS
DT-Board	Digital Tuner (Exchange Only)	TNAG172S
G-Board	Video 3, Headphone Jack	TNPA4266S
GS-Board	SD Card Slot	TNPA4206S
V-Board	Remote Receiver, LED	TNPA4152ADS
P-Board	Power (AC/DC) (Exchange Only)	TZRXN010MRR
Control Panel ASSY	Control Button (Non-Serviceable, Control Panel Assembly should be exchanged for service.)	K0RB00600004

# Differences from Current models

## LX600 LX60

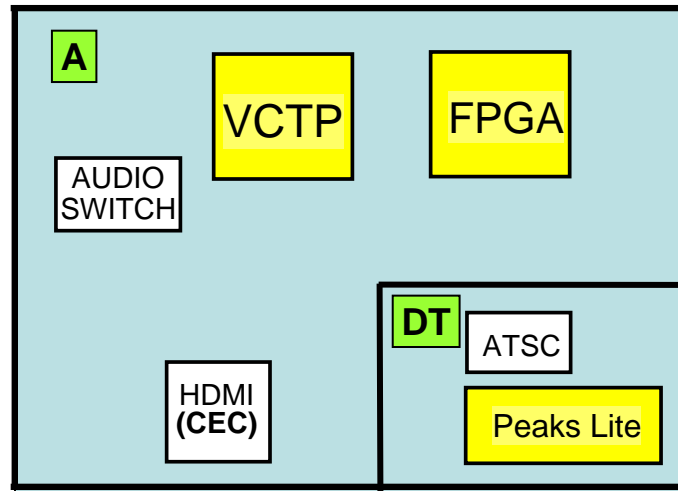

## LX700 LX70

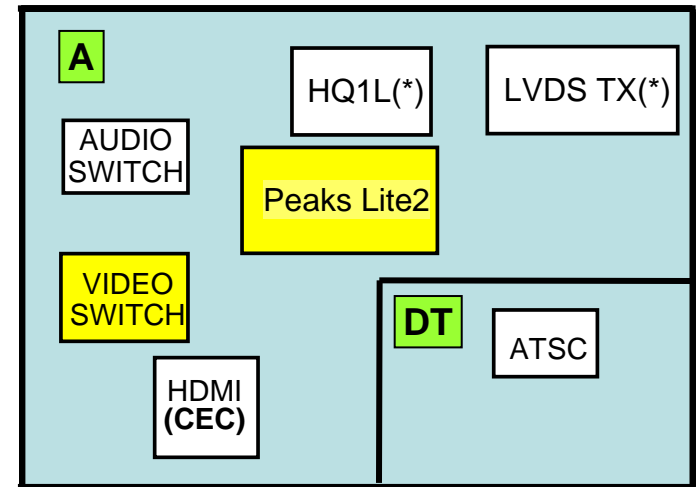

\* 32LX700 only

### Differences from LX600/60:

1. Peaks Lite2 and VIDEO SW are introduced instead of VCTP, FPGA and Peaks Lite .
2. For LX700, HQ1L and LVDS TX are introduced for Motion Picture Pro.
3. HQ1L and LVDS TX are used to convert the picture frames from 60 to 120.  
This process helps to reduce after-images.
4. The DT board of the 32LX700 provides Channel Data output only. The MPEG2 and AC3 (Peaks Lite2) decoders are now part of the A board.

# P Board – Main Power Board

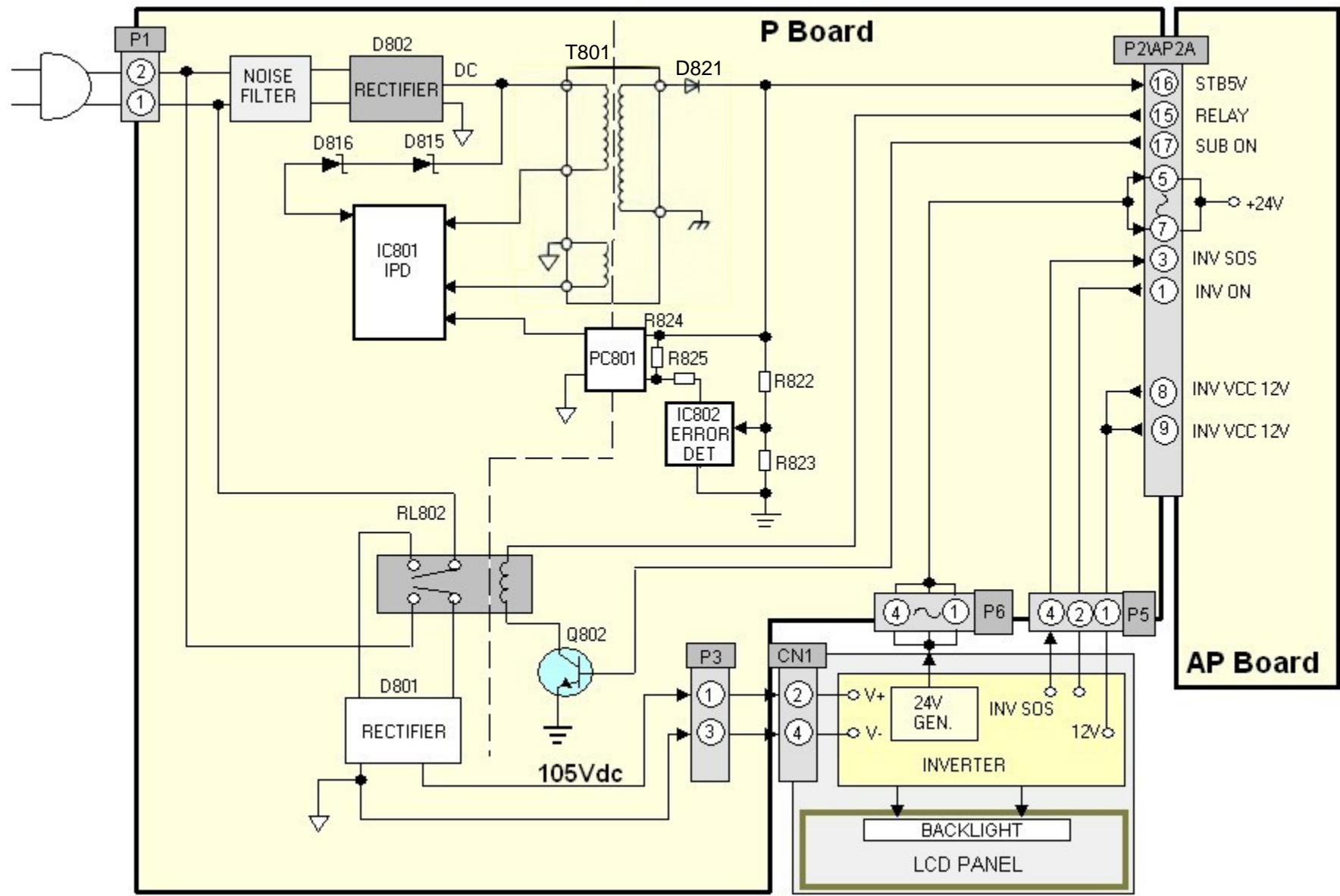

# P Board – Main Power Board

When AC is applied to the TV, the Standby circuit of the P board outputs 5Vdc to the AP board. The STB5V passes through the AP board and enters the A board. On the A board The STB5V is converted to 3.3V to power the system control circuit for standby operation. The STB3.3V is also applied to the Remote Control receiver and the power LED on the V board. The MPU (IC1100) of the A board outputs the SUB\_ON command to provide a ground connection to relay RL802 of the power supply board. On the AP board, the SUB\_ON command is used to turn on a circuit (not shown in the diagram) that provides STB5V to relay RL802 via pin 15 of connector AP2/P2. When the relay is closed, DC voltage from the rectifier, approximately 105Vdc, is supplied to the LCD panel for conversion into 24Vdc. The output of the 24V generator passes through the P board and enters the AP board for conversion into SUB\_5V, DTV9V (SUB\_9V), and HQ3.3V.

If the power button (main unit or remote control) is not pressed within 25 seconds after applying AC to the unit, the SUB\_ON command goes low to disengage the power relay. When the power button is pressed, the SUB\_ON command goes high to repeat the same operation. The voltages remain present until the unit is turned off.

When the unit is turned on, the LCD panel's inverter circuit uses the 24Vdc source to generate the 120Vac to illuminate the CCFLTs. The INV\_ON command and the 12Vdc source enter the panel's drive circuit via the connector AP2/P2 and P5 of the P board. The inverter circuit is monitored for abnormality. When a defect is detected, a SOS (High) output is provided to the A board MPU (IC1100) via Connectors P5 and P2/AP2.

**Caution:** The P board is not to be repaired by you. It is to be exchanged only.

# Main MPU (Power On Commands)

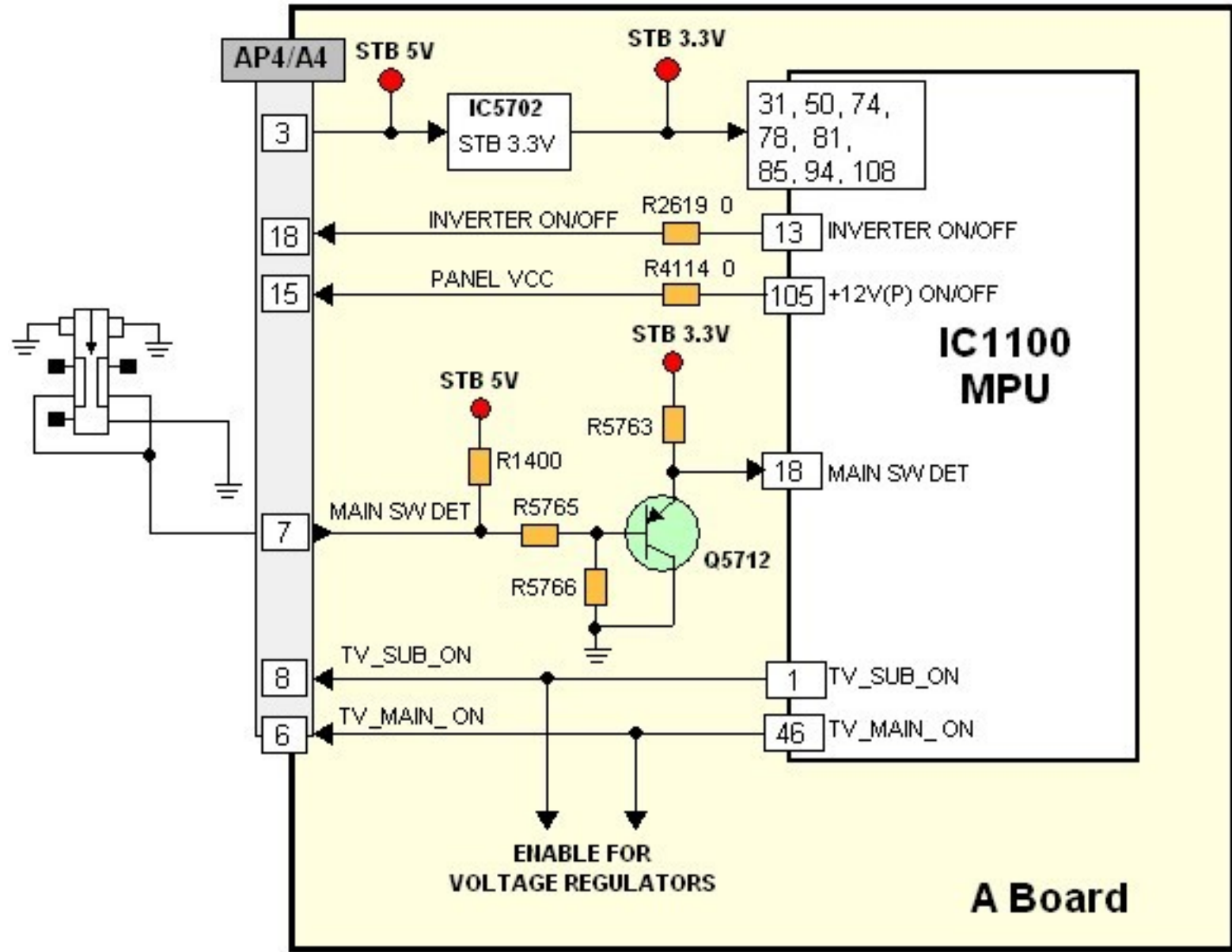

# Main MPU (Power On Commands)

The STB 5V output of the P board passes through the AP board and enters the A board when the unit is plugged into the AC outlet. IC5702 of the A board converts the STB 5V to 3.3V to power the system control circuit. Activation of the power switch causes transistor Q5712 to turn off and output STB 3.3V to pin 18 of the MPU. Upon receiving the STB 3.3V, the MPU (IC1100) outputs the TV-SUB-ON command via pin 8 of connector A4/AP4. The TV-SUB\_ON command is routed to the P board to provide a ground connection for relay RL802 of the power supply board. On the AP board, The TV\_SUB\_ON command is used to turn on a circuit (not shown in the diagram) on the A board that provides STB\_5V to relay RL802. As a result, the switch of relay RL802 on the P board closes to allow the output of 105Vdc to the LCD panel. The TV\_Main\_ON signal issued by IC1100 appears on pin 6 of connector AP4/A4 to enable the output of the sound+12V DC/DC converter. Pin 105 of IC1100 outputs the PANEL VCC command to the AP board to turn on the 12V DC/DC converter. The 12V output is provided to the panel via the P board.

**Caution:** Measure the 105Vdc source between pin 1 and 3 of connector P3. Hot ground must be used.

# Standby Operation

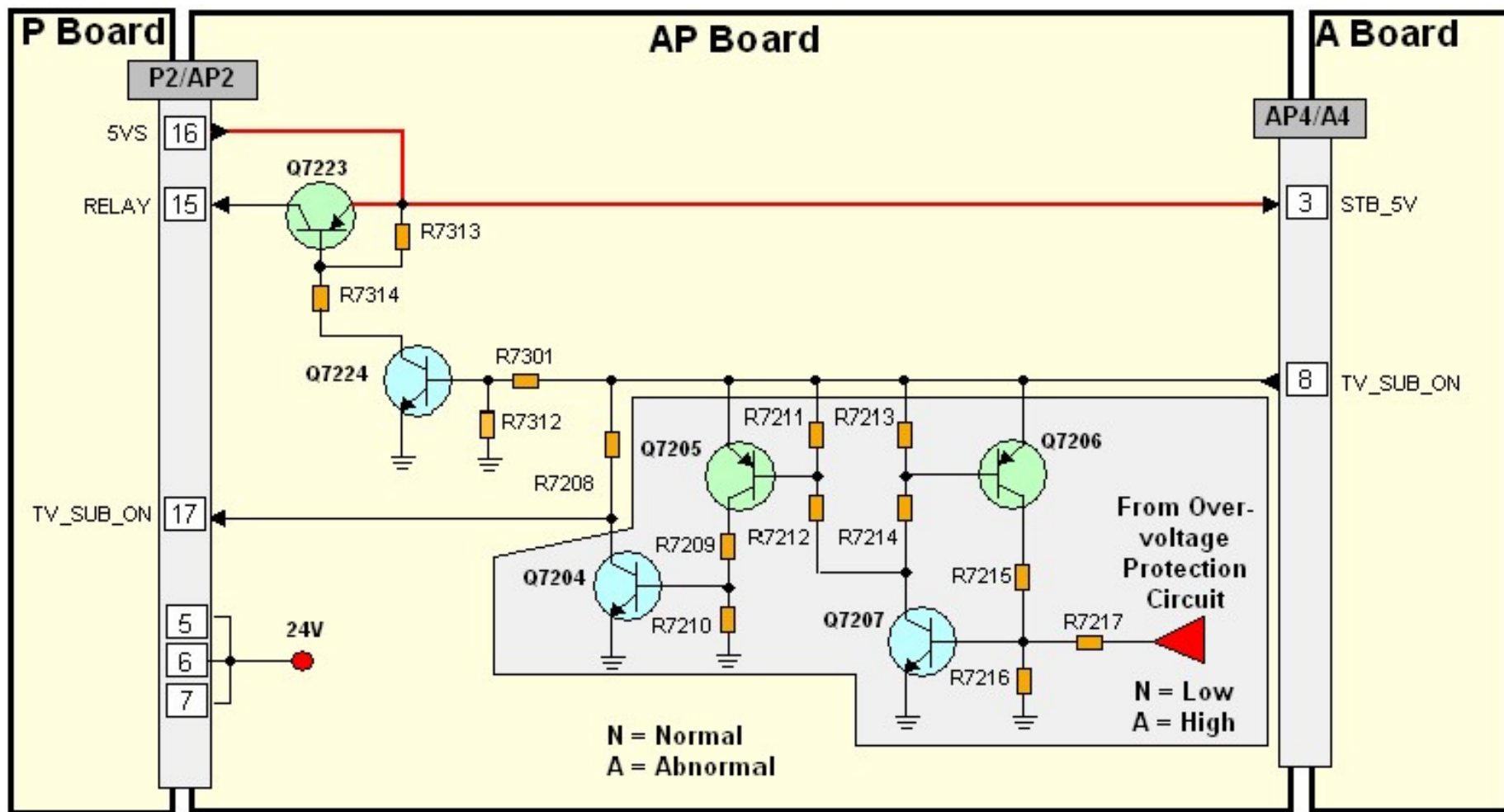

# Standby Operation

When the main power switch is activated, it is sensed on the A board by the MPU IC1100. The TV\_SUB\_ON signal is subsequently issued in response on pin 8 of connector A4/AP4. It turns on the transistors Q7224 and Q7223 to output the “Relay voltage on pin 15 of connector AP2/P2. The TV Sub\_On signal is also provided to the relay via the resistor R7208 and pin 17 of connector AP2/P2. This pulls the contacts of the AC relay on the P board. The AC input is rectified and provided to the LCD panel for conversion into 24Vdc. The 24V is then provided to the inverter circuit of the LCD panel to produce the 120Vac that powers the backlight CCFLTs. The same 24V passes through the P board and enters the AP board for conversion into other voltages.

The over-voltage protection circuitry affiliated with each of the regulators located on the AP board monitors for over-voltage conditions. It is designed to turn off the AC power by disabling the SUB\_ON command that turns on the AC relay.

When an over-voltage condition is detected on the AP board, the voltage at the base of transistor Q7207 goes “high” to turn on Q7207, Q7206, Q7205, and Q7204. The TV\_SUB\_ON voltage at pin 17 of connector A2/AP2 is now grounded through Q7204 and the unit shuts down. To turn the unit back on, disconnect and reconnect the AC cord before pressing the power button.





# Main Voltages and Over-voltage Protection

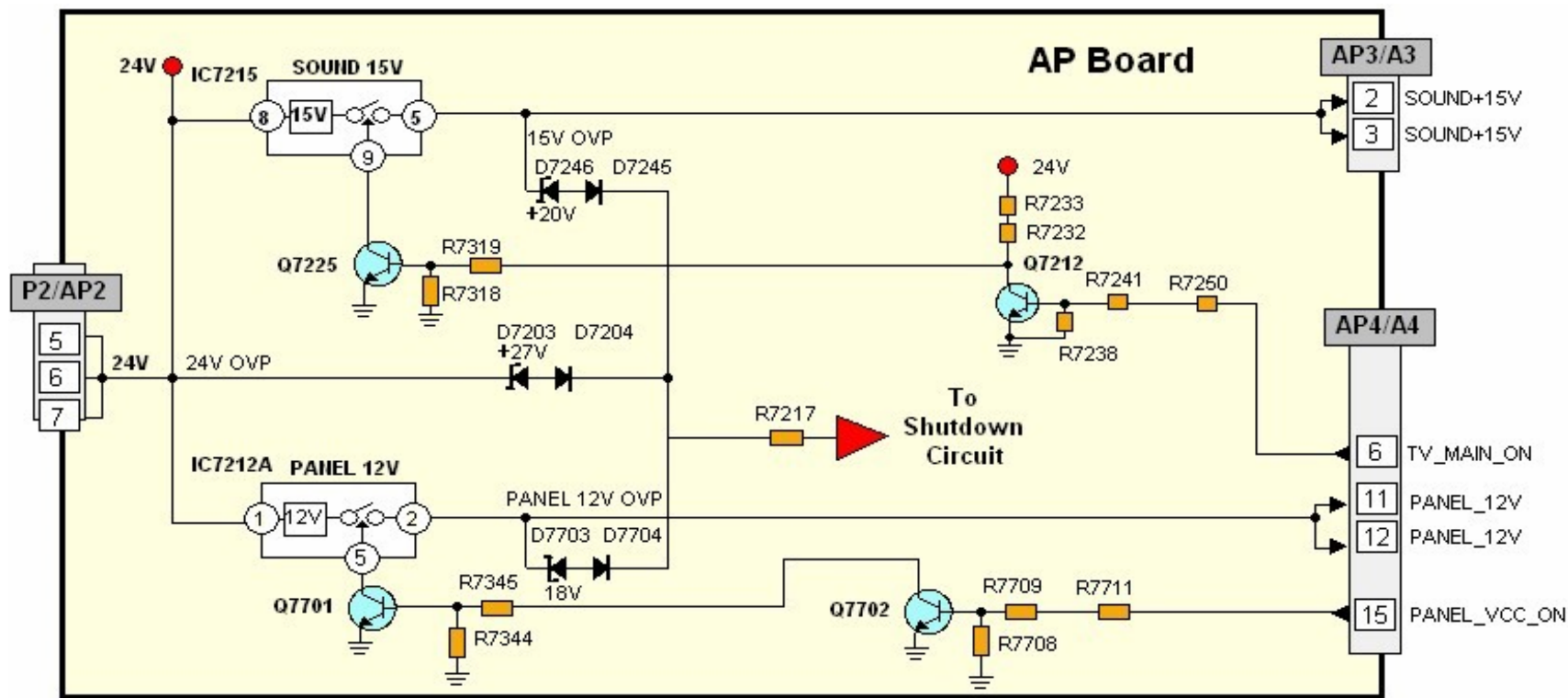

When the unit is turned on, the TV\_Main\_On command (high) of IC1100 biases the transistor Q7212 into operation, causing its collector to go “low”. The low at the collector of Q7212 causes the transistor Q7225 to turn off. As a result, IC7215 goes into operation to provide the Sound\_15V output.

When the Panel\_VCC\_On command is issued, transistor Q7702 turns on causing Q7701 to turn off. Consequently, IC7212 turns on and outputs 12V. This voltage enters the A board via the connector AP4/A4. It is also provided to the LCD panel via the connector AP2/A2, the P board, and the connector P5 (not shown in the diagram).

The over-voltage protection circuitry affiliated with each of the regulators monitors for excessive current and over-voltage conditions. It is designed to turn off the AC power by disabling the SUB\_ON signal needed to turn on the AC relay.

# Inverter\_On Command and Protection

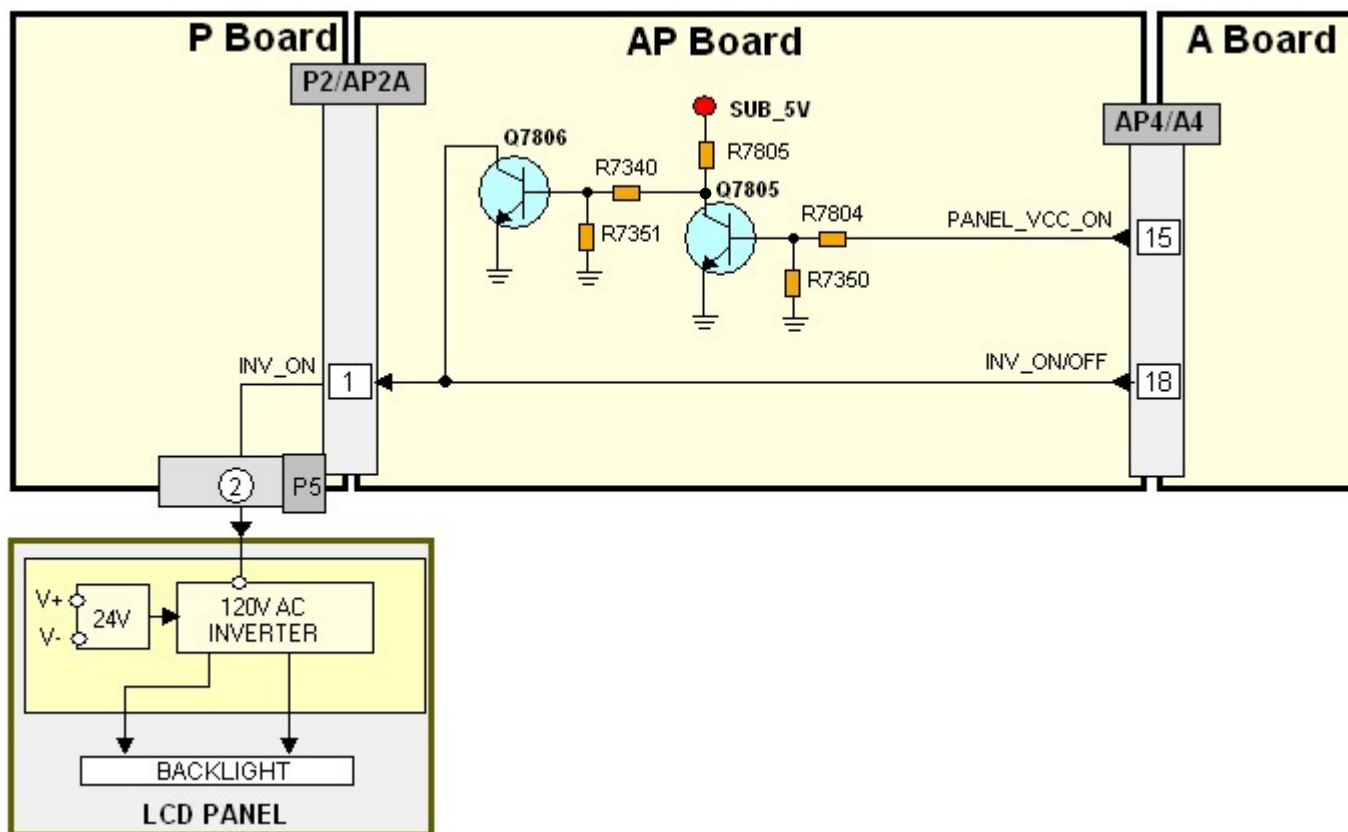

The INV\_ON/OFF command (high) of the MPU, IC1100 of the A board, passes through the AP and P boards before entering the LCD panel. On the LCD panel, it triggers the operation of the inverter to produce the 120V AC that powers the backlight CCFLTs. To avoid catastrophic failures, when the Panel\_VCC\_ON pin of the MPU goes "low", Q7805 turns off. Consequently, Q7806 turns on to disable the operation of the inverter.

Purposely left blank

# Video Process Block Diagram

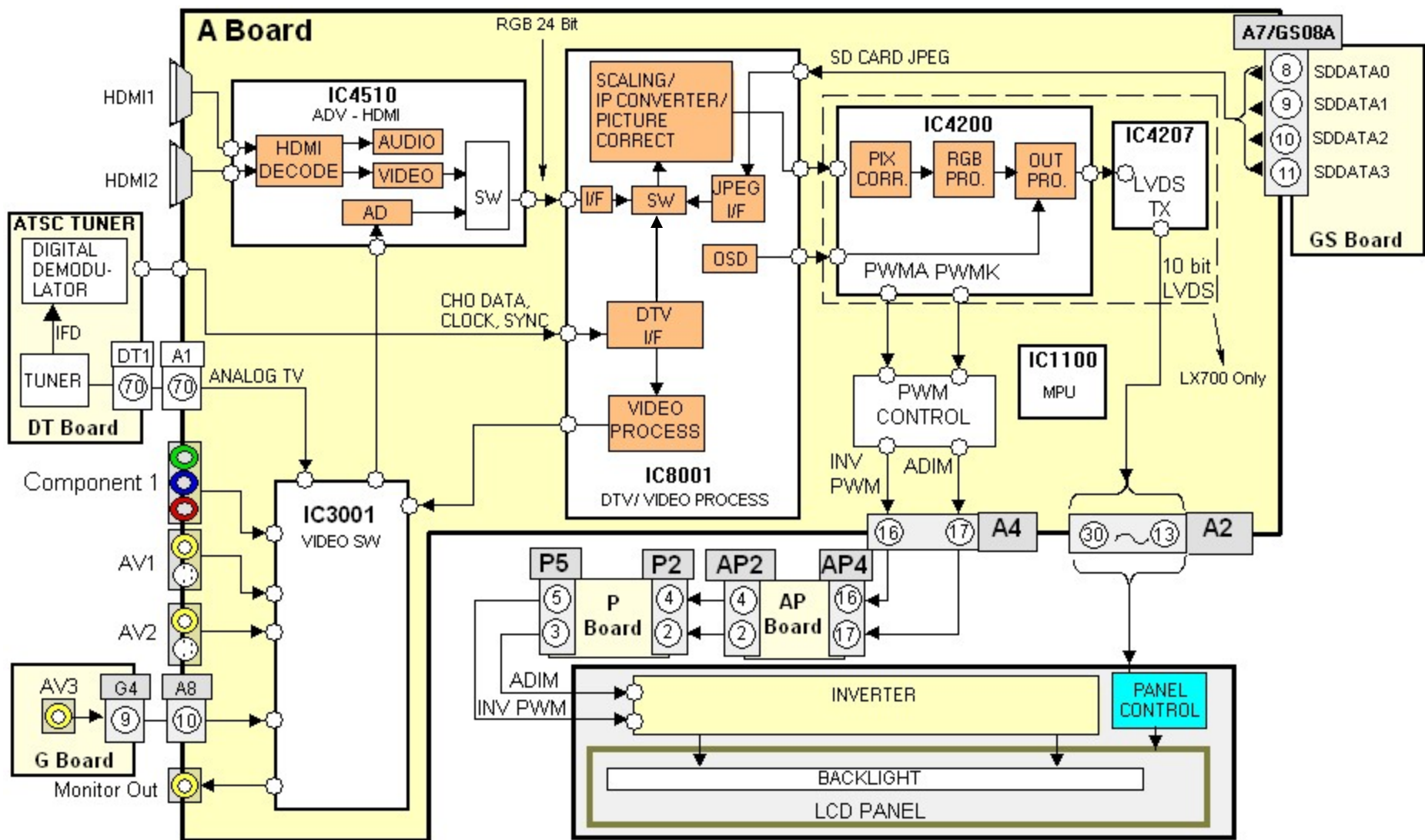

# Video Process Block Diagram

The main function of the A board is to select and process one of the incoming video signals. Video inputs, component video Input, and the composite video output of the tuner are all connected to IC3001 for selection. The video output signal of the switch can be in any of the three formats: Video, Y/C, or Y, Pb, Pr. The selected output enters IC4510, the HDMI IF Receiver/Decoder IC, for A/D conversion. The comb filter inside IC4510 converts the composite video signal of the main picture to Y and C (luminance and chrominance) signals. S-Video, which is already Y/C separated, simply passes through the comb filter. The chrominance data is then applied to the Chroma Demodulator circuit to separate the color signal into Pb and Pr data. At the completion of this process, the format of the composite or S-Video signal is now the same as a digital 480i component signal. If the incoming video is in the 480p, 720P, or 1080i format, the Y, Pb, and Pr signals undergo A/D (analog to digital) conversion only. The 10 bit YUV data is provided to a video switch. The HDMI receiver section of IC4510 converts the incoming HDMI signals to a YUV video signal. The Video interface circuit selects between the two HDMI sources and outputs the YUV signal to the switch. The output of the switch is provided to the PEAKS LITE IC, IC8001.

Digital television reception of the tuner is output in the form of a transport stream (CHODATA). The transport stream enters the DTV I/F (Interface) section of IC8001 where the video signal is extracted and converted to YUV data. The output is provided to the Video Input switch for selection. The JPEG data of the GS board enters the JPEG I/F section of IC8001 for conversion into YUV data and output to the video switch. The video switch outputs the selected picture data to the Video Process circuit.

The Video Process section of the IC performs all picture control operations such as brightness, contrast, color, tint, etc. The output signal is then applied to the HQ1L circuit (IC4200) for frame doubling operation. IC4200 is the circuit responsible for the Motion Picture Pro operation that reduces afterimage by 50%. On Screen Display data such as channel numbers, Digital TV closed caption, and picture adjustments are mixed with the video data. The output of IC4200 is provided to the LVDS transmitter (IC4207). The transmitter distributes signals with low-jitter, while creating little noise. It reduces power consumption and the generated noise from data transmission. Another benefit of the LVDS standard is minimal concern for cable length.

The main MCU (IC1100) controls the entire operation of the A board. It serves as the controller that monitors all operations of the TV section (not display) of the unit. When watching digital television or viewing pictures from an SD card, the video process section of IC8001 converts the digital video into analog composite video signal for output at the monitor out jack.



# Audio Process Block Diagram

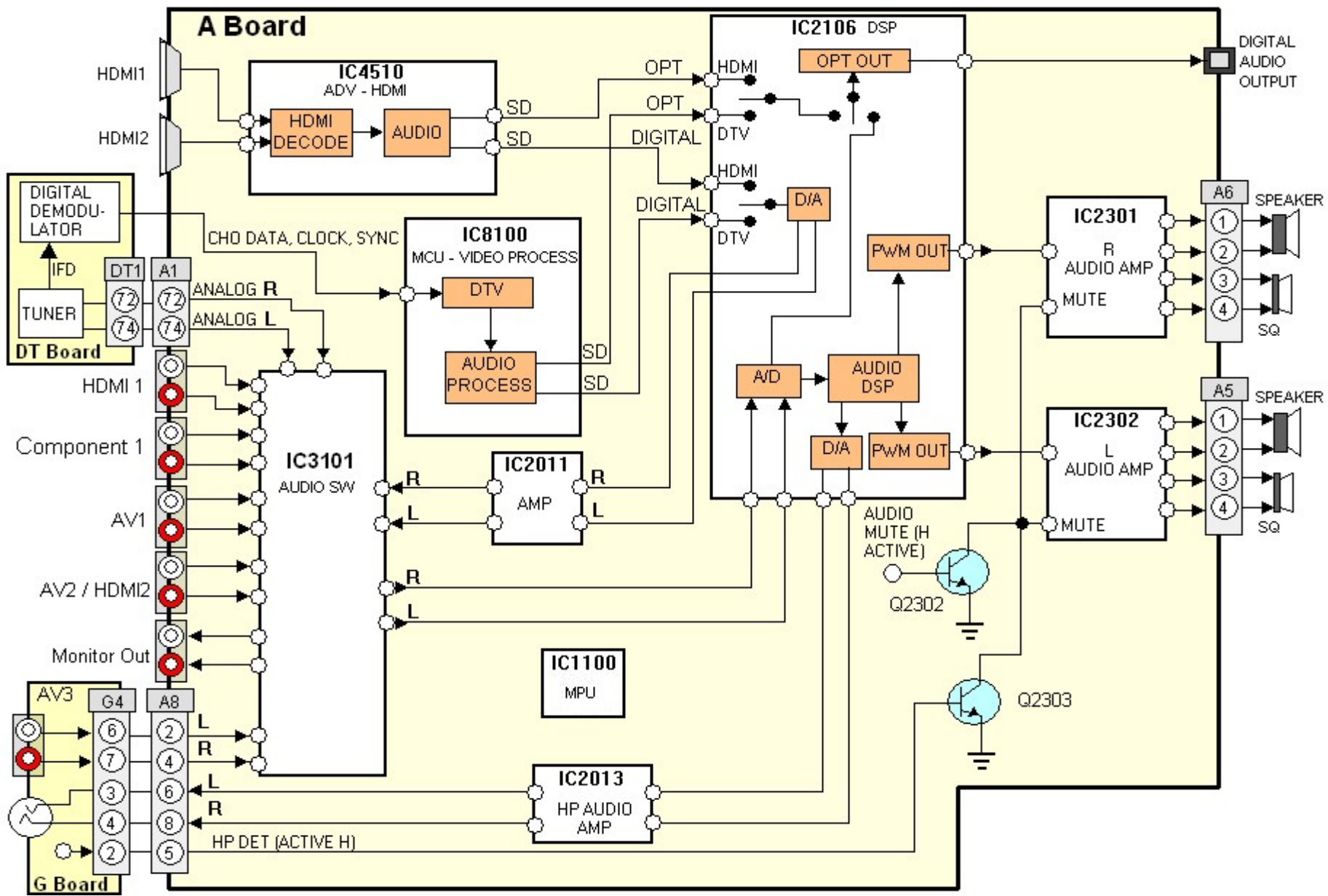

# Audio Process Block Diagram

IC3101 of the A board handles the audio selection of most inputs. Analog audio of the tuner and audio signals from composite, component, and DVI inputs are connected to IC3101 for selection. The output of IC3101 enters IC2106 and undergoes analog to digital conversion. The serial data output is provided to the audio DSP (Digital Signal Processor). Volume, bass, treble, and balance adjustments of the audio signal are performed by this circuit. The output is two channel PWM data that are applied to IC2301 and IC2302 for amplification. The PWM output signals of the power amplifiers are output to the right and left channel speakers for sound reproduction. The HDMI receiver section of IC4510 converts the incoming HDMI audio into serial data. The Audio interface circuit selects between the two HDMI audio and outputs the SD (serial Data) to the switch located inside IC2106. Two outputs are provided, one for the digital audio output jack, the other for the speakers. Digital television reception of the tuner is output in the form of a transport stream that contains MPEG2 video and AC3 audio. The transport stream enters the DTV I/F section of IC8001 where the audio signal is extracted and converted to serial data. Two outputs are provided to IC2106. One output consists of the AC3 audio that will be provided to the digital audio output jack. The other output consists of left and right audio that will be used to drive the speakers. Speaker output of the DTV and HDMI audio is selected and converted to analog. The analog audio is then output to an audio amplifier (IC2011) and then applied to the audio selector (IC3101). The optical jack audio signal is also selected and processed inside IC2106. Q2303 is a muting transistor that applies a low to IC2106 when a headphone jack is connected to the unit. Q2302 applies a low to IC2106 when the mute function of the unit is active.



# MPU SOS Inputs and Blink Codes

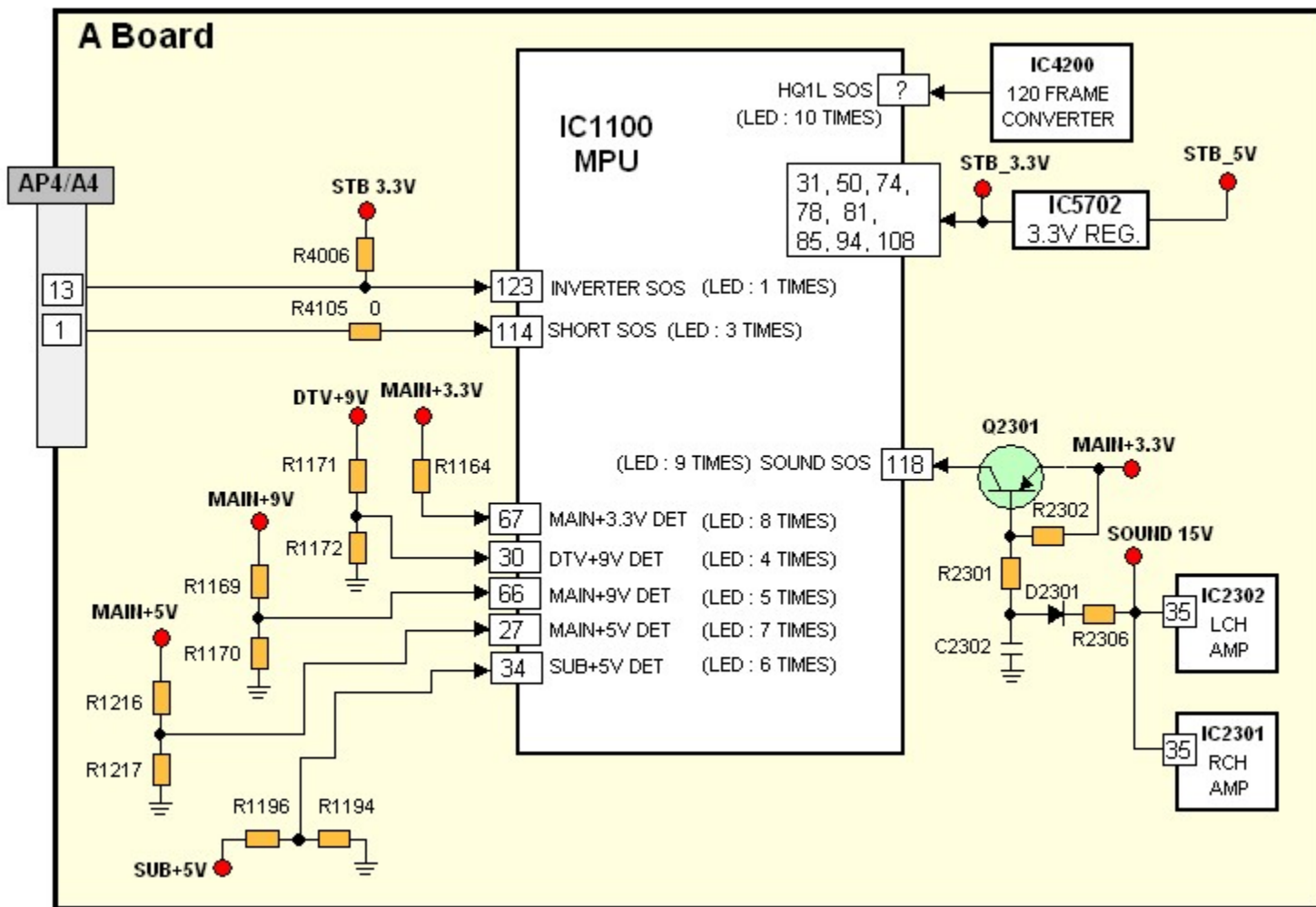

# MPU SOS Inputs and Blink Codes

**One Blink:** One blink of the power LED indicates a problem in the inverter circuit located on the LCD panel. The inverter board is not to be repaired in the field. Therefore a replacement is required.

**Three Blinks:** Three blinks of the power LED indicates an over-current or over-voltage condition in one of the DC supplies of the AP board. The AP board is repairable. Therefore the use of an ohmmeter and peak-hold-voltmeter is required to determine the cause of the shutdown. An over-voltage condition is definitely a defect of the AP board. An over-current condition may be due to a short circuit located in the AP board, A board, or the LCD panel.

**Five, Seven, or Eight Blinks:** The A board is responsible for five, seven or eight blinks of the power LED. The MAIN +3.3V, MAIN +5V, and MAIN +9V sources are all produced on the A board. The detection input pins of the MPU, IC1100, monitor for their presence.

**Four or Six Blinks:** The AP board is responsible for four or six blinks of the power LED. The DTV9V, and SUB\_5V sources are produced on the AP board. The MPU IC1100 monitors for their presence when the unit is connected to AC Power. A short or open circuit on the A board may also be responsible for their absence.

**Nine Blinks:** Nine blinks of the power LED is due a short circuit in the audio output circuit (s) of the unit. The audio output circuit is located on the A board. Confirm the status of the speakers. If defective, perform a replacement. If ok, replace the A board.

**Ten Blinks:** Ten blinks of the power LED indicates a malfunction of IC4200, the frame converter. This IC resides on the A board. Therefore ten blinks of the power LED requires the replacement of the A board.

# Over-Current Protection Circuit

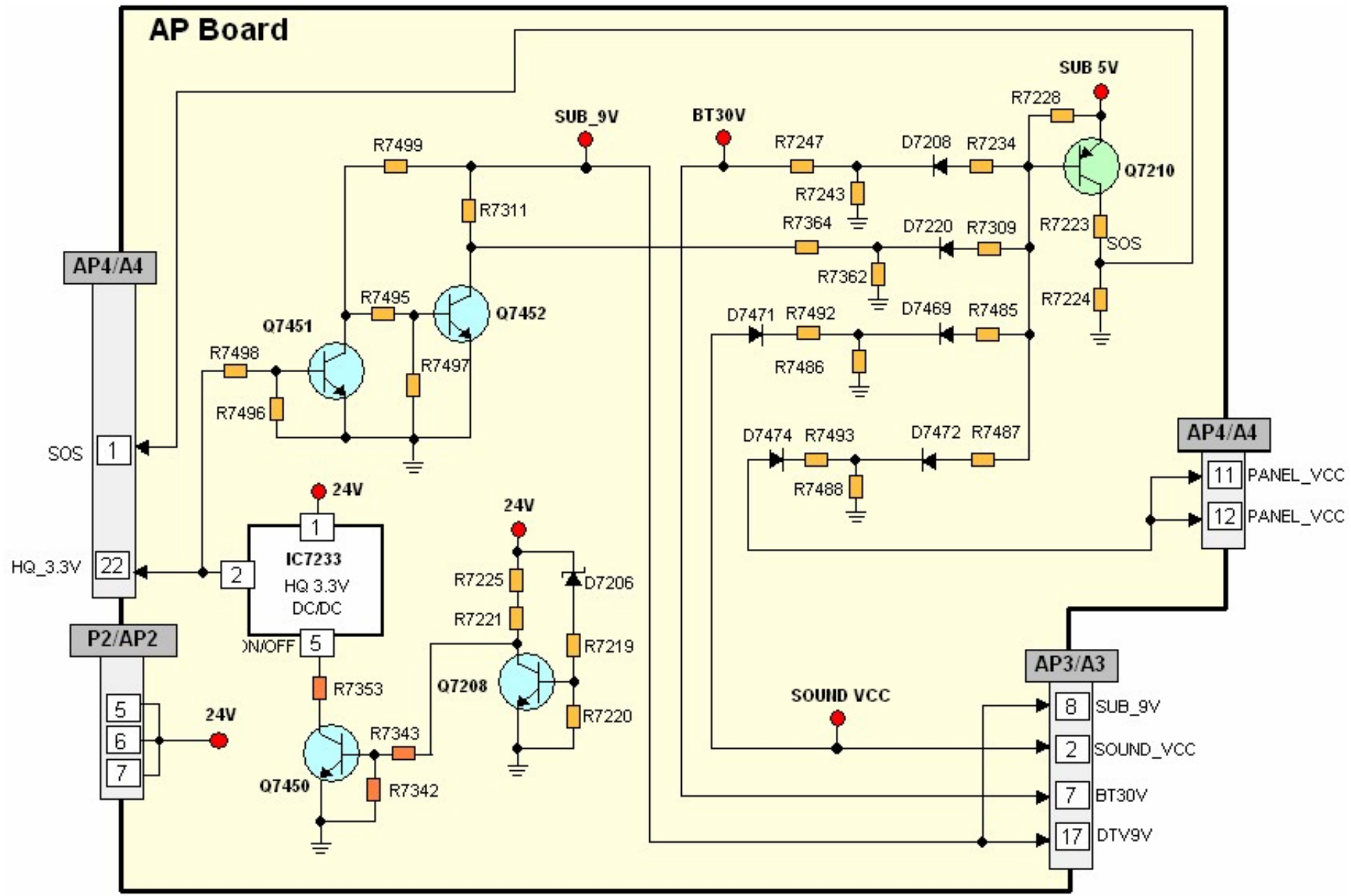

# Over-Current Protection Circuit

The protection shutdown circuit is designed to monitor for a short or loss of the SUB\_9V, SOUND\_VCC, BT30V, and the Panel VCC sources. If any of these voltage sources goes low, Q7210 turns on. As a result, the collector of Q7210 goes high to signal a shutdown condition to IC1100 on the A board. The TV\_SUB\_ON pin of IC4002 goes low to deactivate the AC relay on the P board.

During standby operation, the 24 volt output of the P board biases the transistor Q7208 into conduction, causing its collector to become “low”. The low at the collector of Q7208 causes the transistors Q7450 to turn off. As a result, IC7233 goes into conduction to immediately provide the HQ 3.3V output. When the 24 drops below the reverse breakdown voltage of D7206, transistor Q7208 turns off and transistor Q7450 turns on. IC7233 ceases to operate causing Q7451 to turn off and Q7452 to turn on. Consequently, the SUB\_9V line is now grounded. Diode D7220 becomes forward biased and Q7210 outputs a high to trigger the shutdown of the unit.

# Over-Current Protection Circuit 2

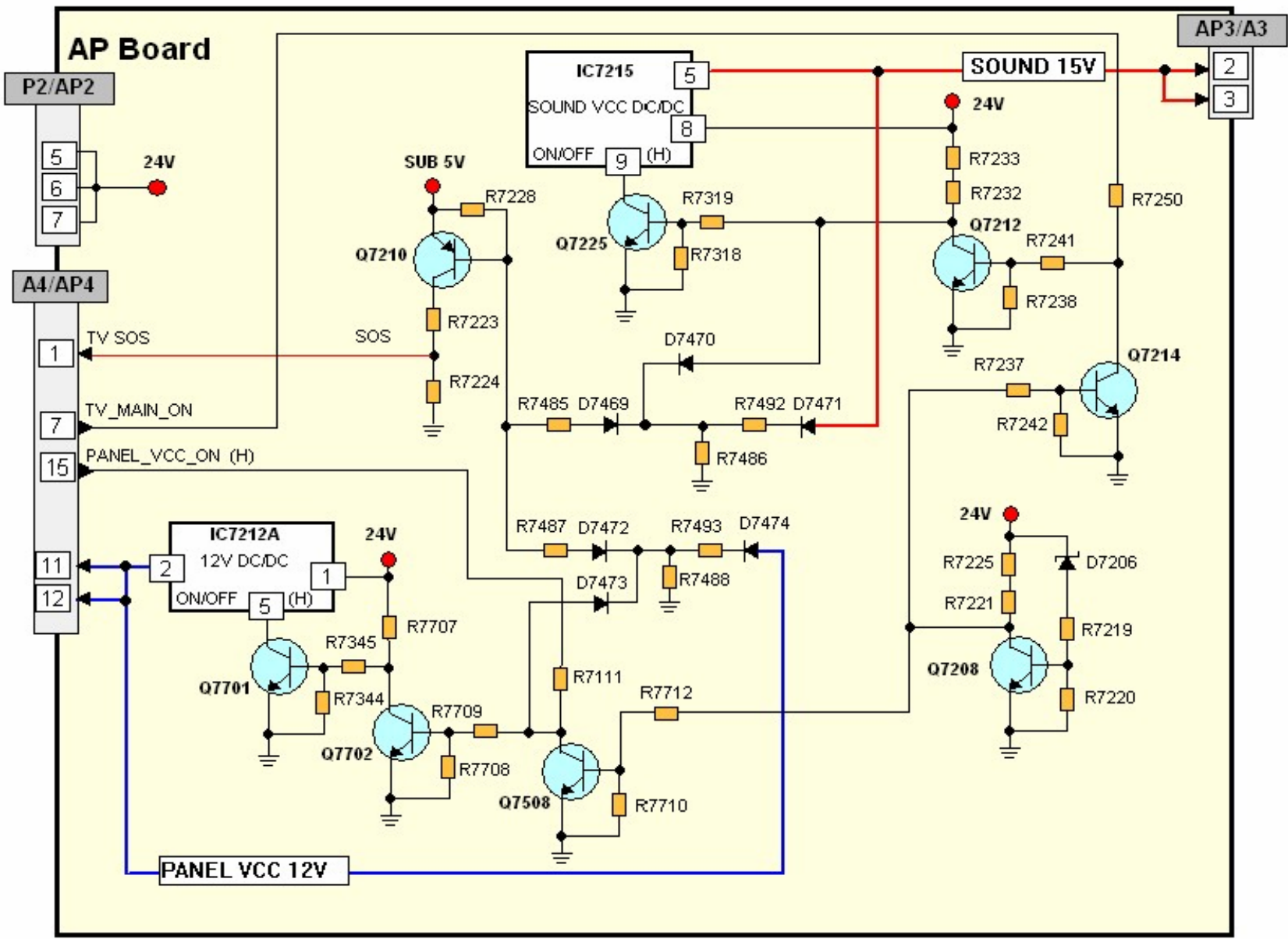

# Over-Current Protection Circuit 2

## Sound\_VCC Protection

During normal operation, the 24 volt output of the P board biases the transistor Q7208 into conduction, causing its collector to become low. The low at the collector of Q7208 causes the transistor Q7214 to turn off. When the PANEL\_MAIN\_ON command (high) is issued Q7212 turns on. Consequently Q7225 turns off, and IC7215 goes into conduction to provide the SOUND\_15V output.

When the 24 drops below the reverse breakdown voltage of D7206, Q7208 turns off, Q7214 turns on to ground the PANEL\_MAIN\_ON voltage. Q7212 turns off and Q7225 turns on. IC7215 ceases to operate and the Sound\_VCC is no longer output.

During normal operation, the anode of D7469 receives 5V and the junction of D7469, D7470, R7486, and R7492 receives 12V. Due to this condition, the transistor Q7210 remains off. If the SOUND\_15V line becomes shorted, diode D7469 goes into conduction to turn Q7210 on. Consequently Q7210 outputs a high to shut down the unit.

## Panel\_VCC Protection

During normal operation, the 24 volt output of the P board biases the transistor Q7208 into conduction, causing its collector to become low. The low at the collector of Q7208 causes the transistor Q7508 to turn off. When the PANEL\_VCC\_ON command (high) is issued, Q7702 turns on. Consequently Q7701 turns off, and IC7212 goes into conduction to provide the PANEL\_12V output.

When the 24 drops below the reverse breakdown voltage of D7206, Q7208 turns off, Q7508 turns on to ground the PANEL\_VCC\_ON voltage. Q7702 turns off, and Q7701 turns on. IC7212 ceases to operate and the Panel\_VCC is no longer output.





During normal operation, the anode of D7472 receives 5V and the junction of D7472, D7473, R7493, and R7488 receives 12V. Due to this condition, the transistor Q7210 remains off. If the Panel\_12V line becomes shorted, diode D7472 goes into conduction to turn Q7210 on. Consequently Q7210 outputs a high to shut down the unit.

When the unit is turned on, the TV\_Main\_On command (high) of IC1100 biases the transistor Q7212 into operation, causing its collector to become "low". The low at the collector of Q7212 causes the transistors Q7225 to turn off. As a result, IC7215 goes into operation to provide the Sound\_15V output.

# Power LED Timing Table

Blinking Times	Blinking Timing	Contents	Check Points
1	<p>once</p> <p>3 sec</p> <p>-- Light</p> <p>- - No Light</p>	INVERTER SOS	LCD PANEL
3		BT 30V SOUND 15V PANEL 12V	AP-BOARD
4		DTV 9V	AP-BOARD
5		MAIN 9V	A-BOARD

# Power LED Timing Table

Blinking Times	Blinking Timing	Contents	Check Points
6		SUB 5V	AP-BOARD
7		MAIN 5V	A-BOARD
8		MAIN 3.3V	A-BOARD
9		SOUND SOS	A-BOARD AP-BOARD
10		HQ1L SOS	A-BOARD



# Self-Check and Reset Function

## Self-Check Function:

1. Checks the communication IIC bus lines
2. Provides a SOS History

To Access the Self-Check Mode: Turn the TV on and select an active channel. While pressing the “VOLUME ( - )” button on the main unit, press the “OK” button on the remote control for more than 3 seconds.

This procedure is useful to display the unit’s firmware version and check IC data communications.

To Reset the unit: Turn the TV on and select an active channel. While pressing the “VOLUME ( - )” button on the main unit, press the “Menu” button on the remote control for more than 3 seconds.

The Reset function clears channel programmed settings, picture settings, channel labels, LOCK mode settings, and password.

**It restores the unit to factory shipping settings.**

To Exit the Self-Check Mode, Disconnect the AC cord from the wall outlet.

SELF CHECK

----.XXXXXX-XXXXXX

DT	OK
HQ1L	OK
ADV	OK
VSW	OK
ADAV	OK
ASW	OK
TUN1	OK
TUN2	OK
FE	OK
GenX4	OK

MEM1	OK
MEM2	OK

Copyright 2007 Matsushita Electric Industrial Co., LTD

## Check Point

DISPLAY	Ref. No.	Description	P.C.B.
DT	IC8001	Peaks 2	A-Board
HQ1L	IC4200	HQ1L	A-Board
ADV	IC4510	A/D CONV. , HDMI RX	A-Board
VSW	IC3001	VIDEO SW	A-Board
ADAV	IC2106	AUDIO DSP	A-Board
ASW	IC3101	AUDIO SW	A-Board
TUN1	TU8300	TUNER (PLL block)	DT-Board
TUN2	TU8300	TUNER (MTS block)	DT-Board
FE	IC8302	FRONT END (Digital demodulator)	DT-Board
GenX4	IC1100	GenX4 (STB MCU)	A-Board
MEM1	IC1101	EEPROM (GenX4)	A-Board
MEM2	IC8503	EEPROM (Peaks)	A-Board

**To enter the Serviceman Mode**, turn the TV on and while pressing the “VOLUME ( - )” button on the main unit, press the “RECALL” button of the remote control three times within 3 seconds.

**To exit the Serviceman Mode**, Press the Power button on the TV or the Remote Control.

# Serviceman Mode Menu and Navigation

**SERVICE  
ADJUST  
WB-ADJ  
OPTION  
RM-SET  
SRV-TOOL**

<b>Peaks Soft</b>	<b>0.270</b>
<b>Peaks EEP</b>	<b>1.00</b>
<b>LSI DATA</b>	<b>0.00.36</b>
<b>GenX SOFT</b>	<b>0.23.00</b>
<b>GenX EEP</b>	<b>0.40.00</b>
<b>GenX COR</b>	<b>0.00.00</b>
<b>HQ1L EEP</b>	<b>15</b>

NOTE: This is  
not part of the  
Menu.

## **Key command**

“1” button...Main items Selection in forward direction

“2” button...Main items Selection in reverse direction

“3” button...Sub items Selection in forward direction

“4” button...Sub items Selection in reverse direction

“VOL” button...Value of sub items change in forward direction ( + ), in reverse direction ( - )

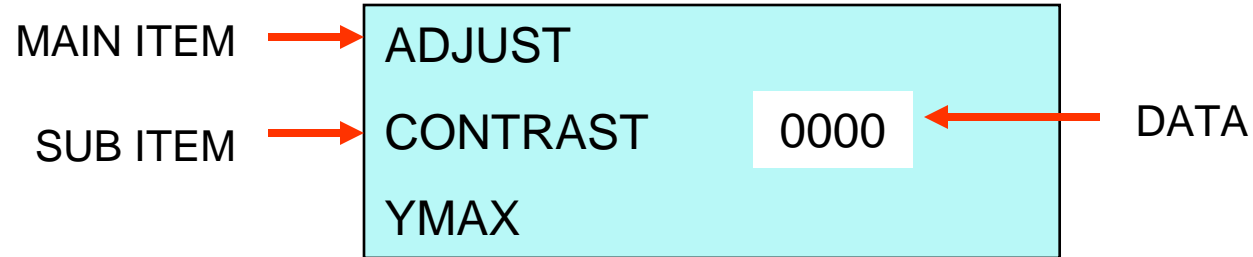

“1” or “2” button of the remote control to select the main Adj. item

“3” or “4” button of the remote control to select the sub Adj. Item

“Vol. (-)” or “Vol. (+)” to change the data

**Note:** Record the original data on a sheet of paper prior to making any adjustment.

SRV-TOOL	
<b>TD2Microcode: 81c0000e</b>	
<b>Flash ROM: 1- 227E</b>	
<b>PCTC: 00 . 00 . 00 . 00 . 00</b>	<b>Time 000040:40 Count 0000049</b>

To access:

1. Select "SRV-TOOL" in the Serviceman Mode menu.
2. Press the [OK] button on the remote control.



## Display of SOS History

### SOS History

(Number of LED blinking) indication. From the left side; Last SOS, before Last, third occurrence before last, 2<sup>nd</sup> occurrence after shipment, 1<sup>st</sup> occurrence after shipment. This indication will be cleared by entering the “Self-check mode. The unit will be forced to factory shipment setting”.

### POWER ON TIME/COUNT

Time: Cumulative power on time, indicated in decimal numbers\_\_ hour: minute

Count: Number of power on/off times in decimal numbers

This indication will not be cleared by self-check or any command.

### Exit:

Disconnect the AC cord from wall outlet.

## AP-board

VOLTAGE	TEST POINT	SPECIFICATION	CONNECTOR
24V	TP7904	$24.0 \pm 1.2V$	AP2_PIN 1, 2, 3
SUB_5V	TP7211	$5.12 \pm 0.25V$	AP3_PIN 21, 22
SUB_9V	TP7213	$9.27 \pm 0.45V$	AP3_PIN 8, 17, 18
BT_30V	TP7601	$31.5 \pm 2.5V$	AP3_PIN 7
HQ_3.3V	TP745	$3.38 \pm 0.17$	A-Board
SOUND_15V	TP7209	$15.2V \pm 0.75V$	AP3_PIN 2, 3
PANEL_12V	TP7702	$12.14 \pm 0.6V$	AP4_PIN 11, 12
STB_5V	TP7151	$5.0 \pm 0.5V$	AP4_PIN 3

## P-board

VOLTAGE	TEST POINT	SPECIFICATION
STB_5V	TP823	$5.0 \pm 0.5V$

## A-board

VOLTAGE	TEST POINT	SPECIFICATION
STB3.3V	TP7006	$3.3 \pm 0.16V$
SUB1.2V	TP5601	$1.26 \pm 0.06V$
SUB1.8V	TP5602	$1.83 \pm 0.09V$
SUB3.3V	TP5600	$3.3 \pm 0.16V$
MHQ1.2V	TP4209	$1.22 \pm 0.06V$
MHQDDR2.5V	TP4210	$2.5 \pm 0.12V$

## A-board → DT-board

VOLTAGE	TEST POINT A- BOARD	SPECIFICATION
SUB_3.3V	TP8332	$3.3 \pm 0.16V$
SUB_1.2V	TP8328	$1.26 \pm 0.06V$
SUB_5V	TP8326	$5.12 \pm 0.25V$
30V_A	TP8331	$31.5 \pm 2.5V$

Purposely left blank

# Troubleshooting Signal Problems

We can classify the signal problem into three categories. It is important to check all functions to determine whether both picture and sound problem exist. Checking all functions helps us determine whether the cause of the problem is the panel, the video processor or sound processor.

**1) Picture NG and Sound OK**

**2) Picture OK and Sound NG**

**3) Picture NG and Sound NG**

# Picture NG and Sound OK (LX700/LX70 )

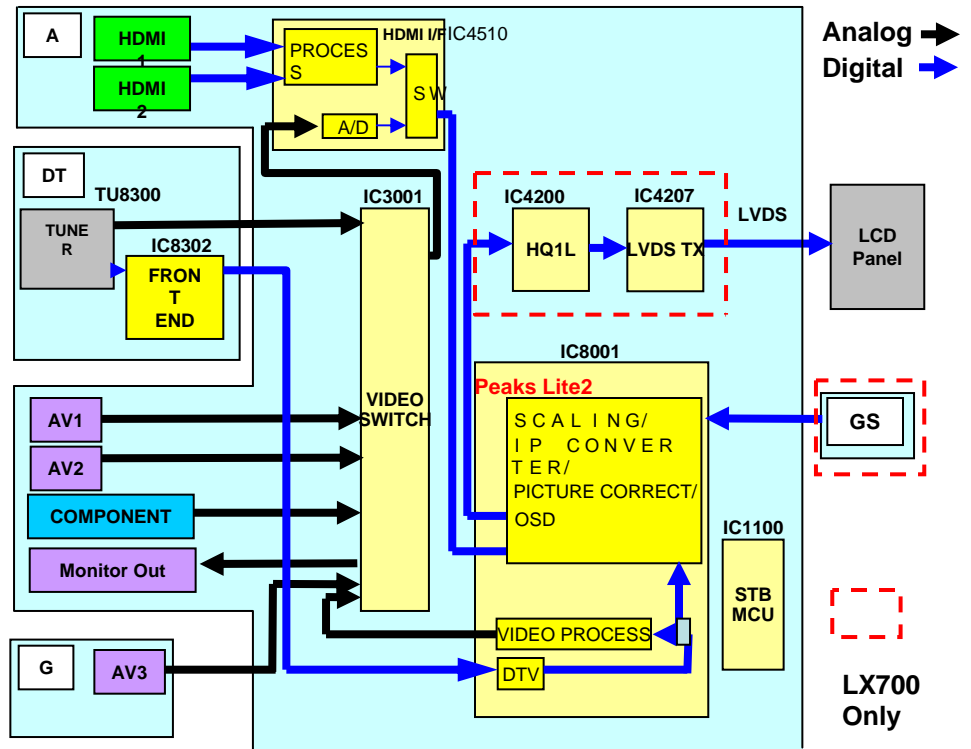
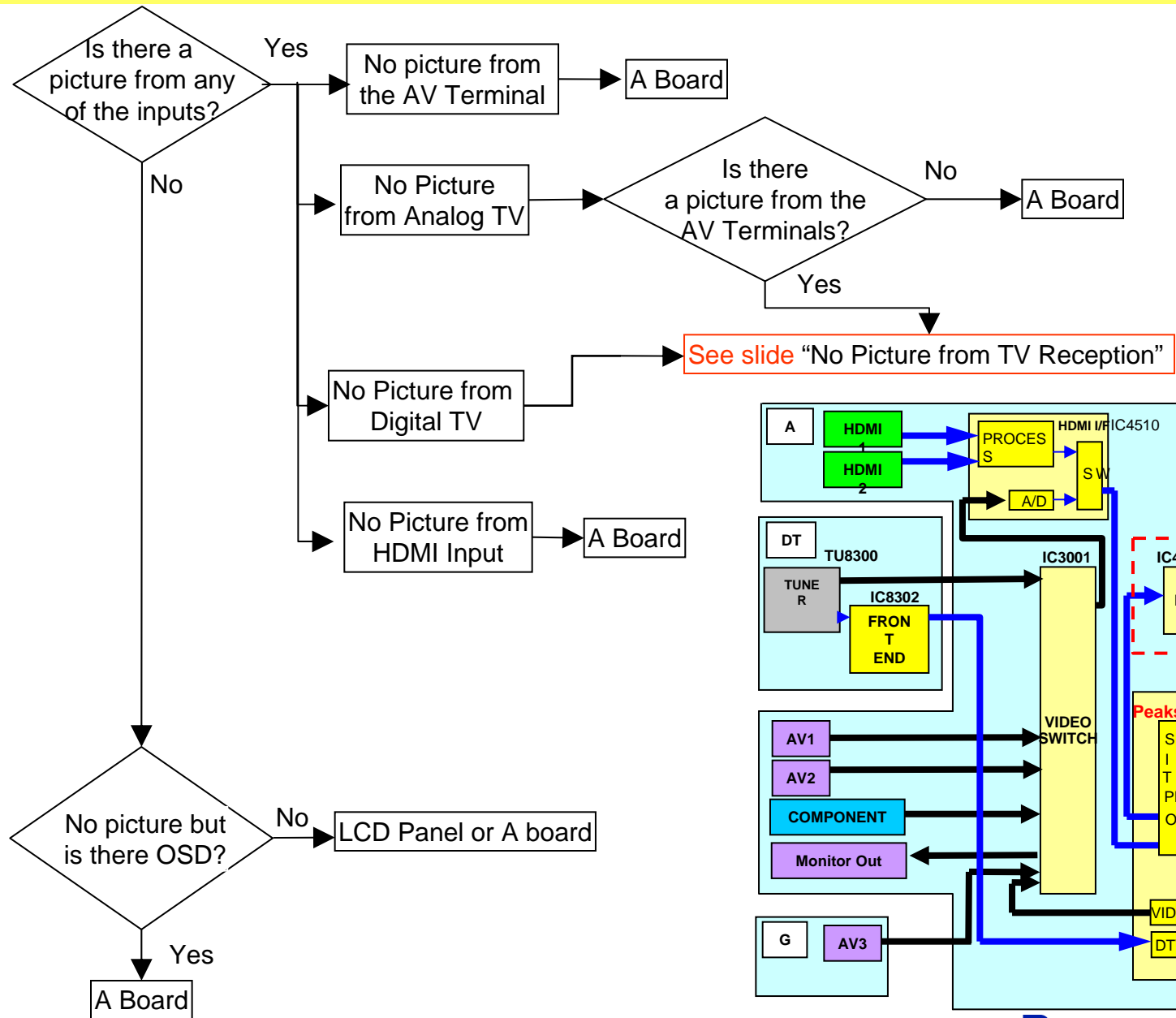



# Picture OK and Sound NG (LX700/LX70)

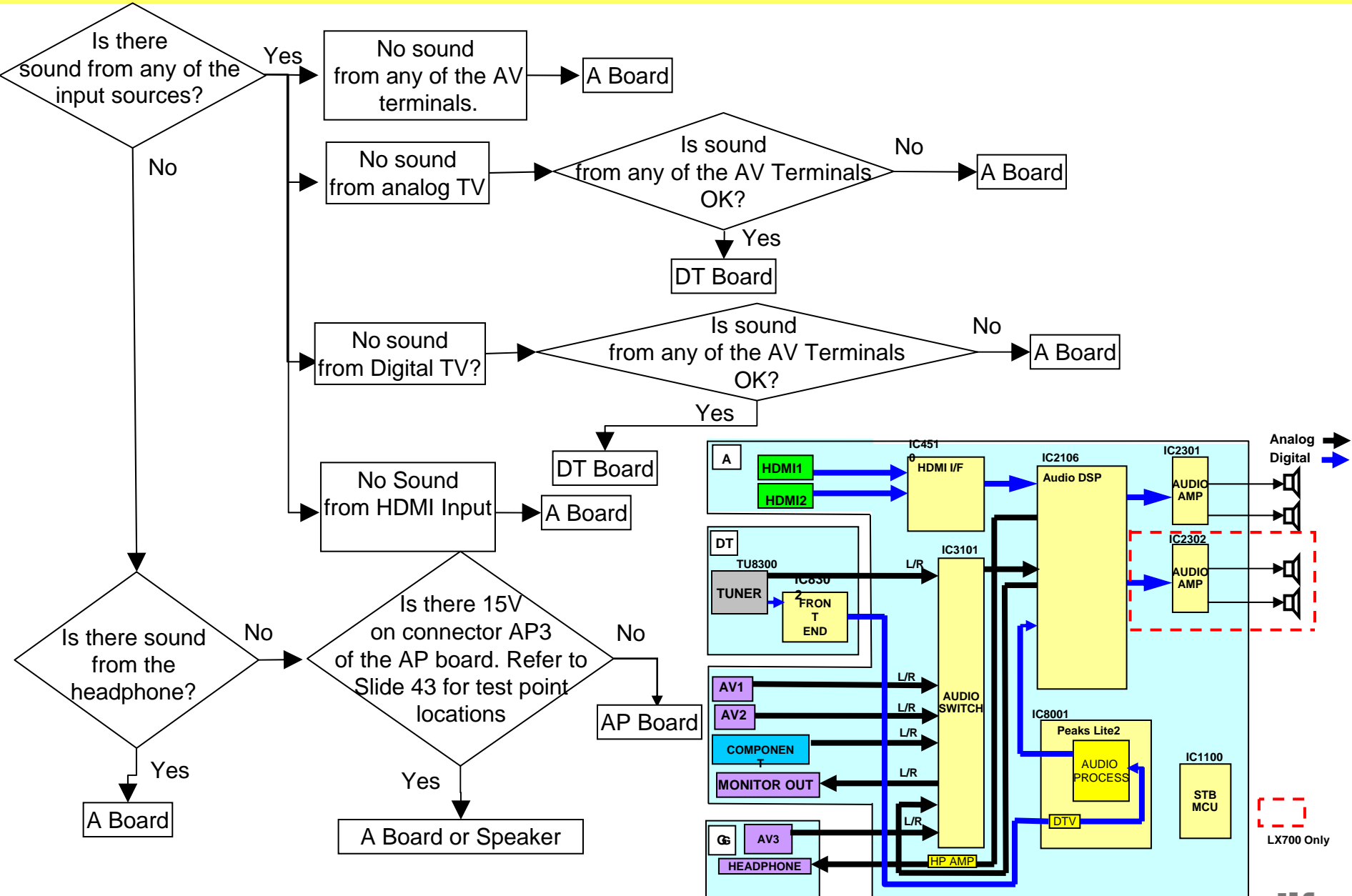

# Picture NG and Sound NG (LX700/LX70)

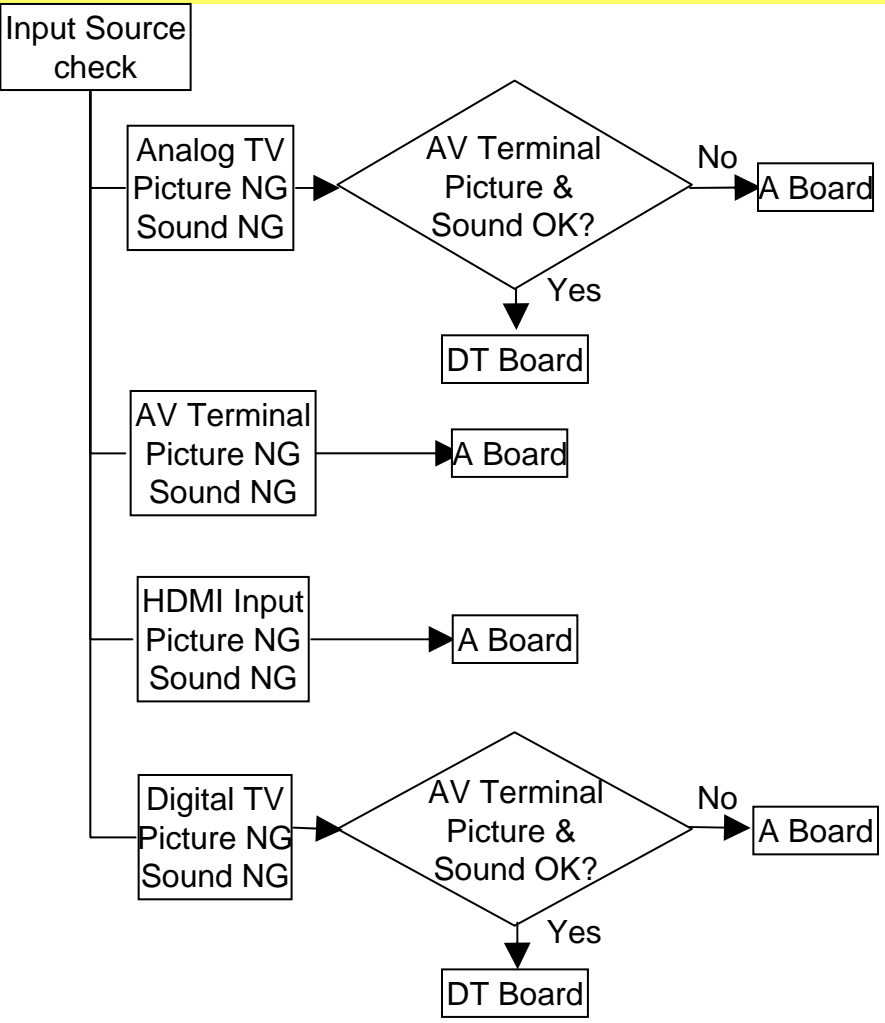

→ Line where problem might occur

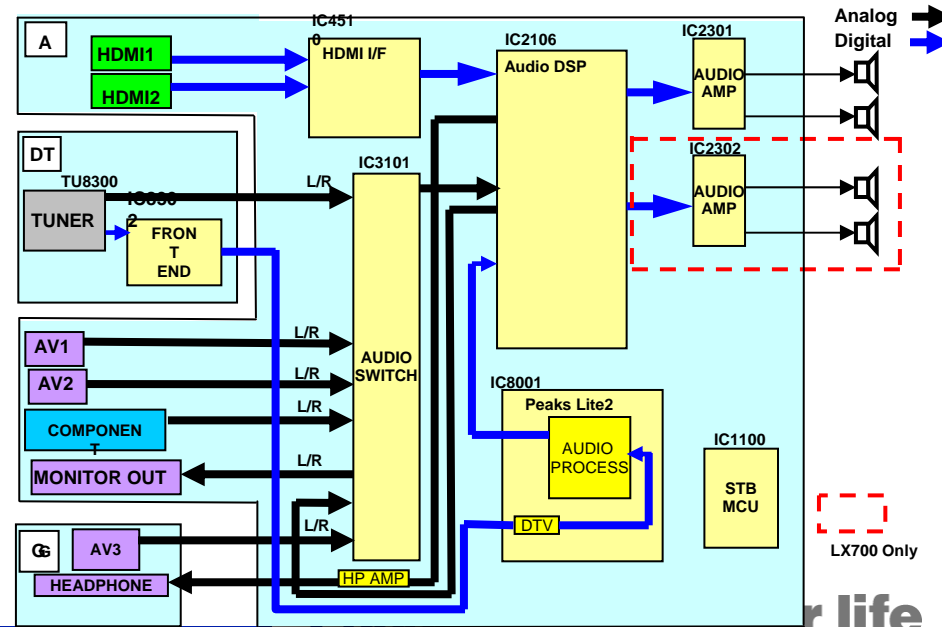
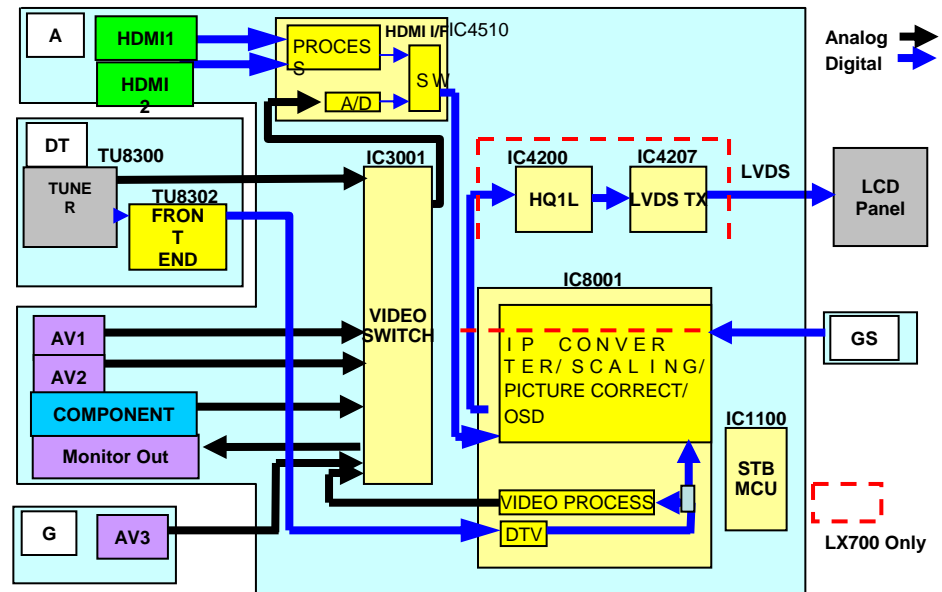

# No Picture from TV Reception

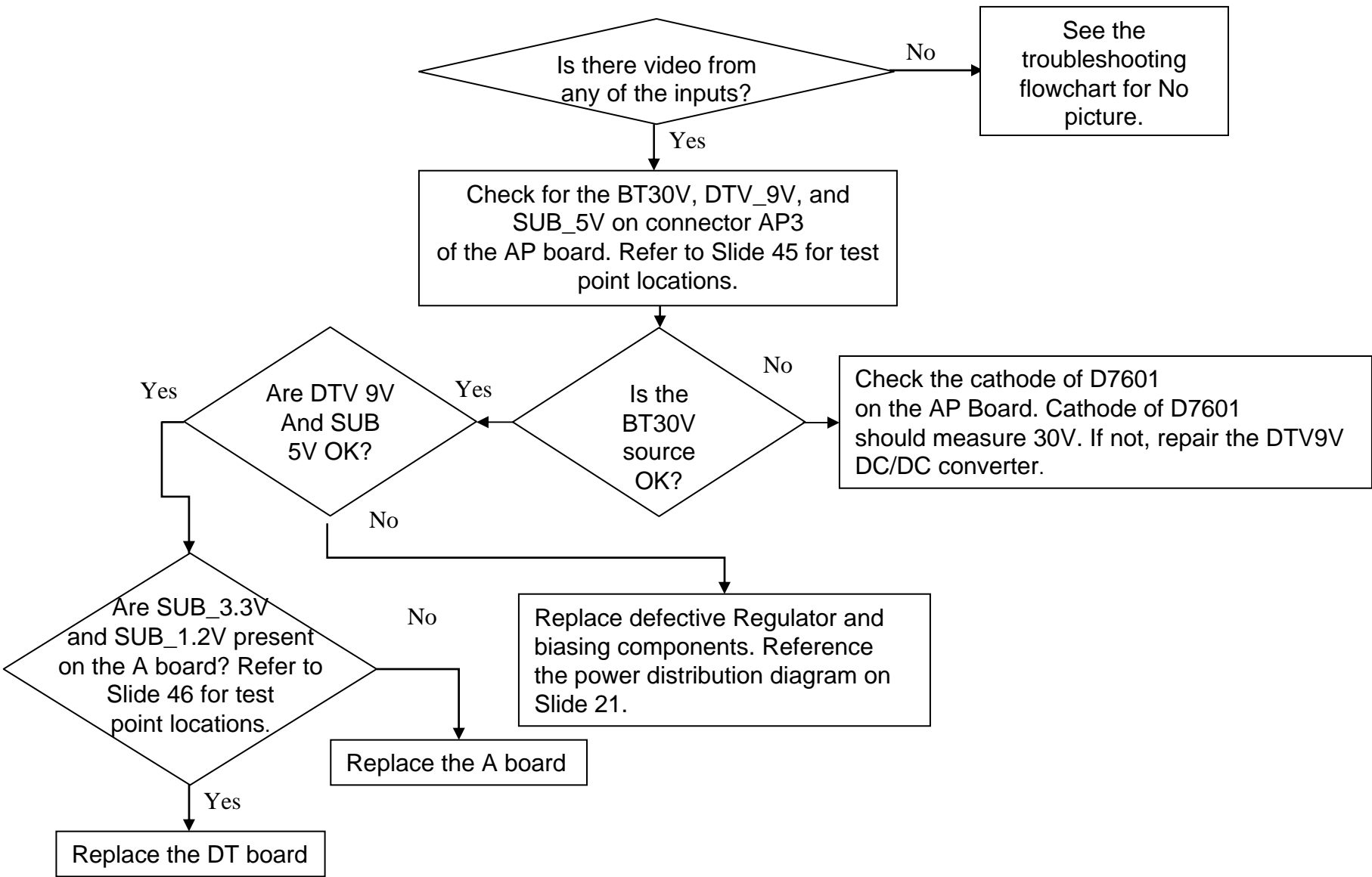

# No Picture

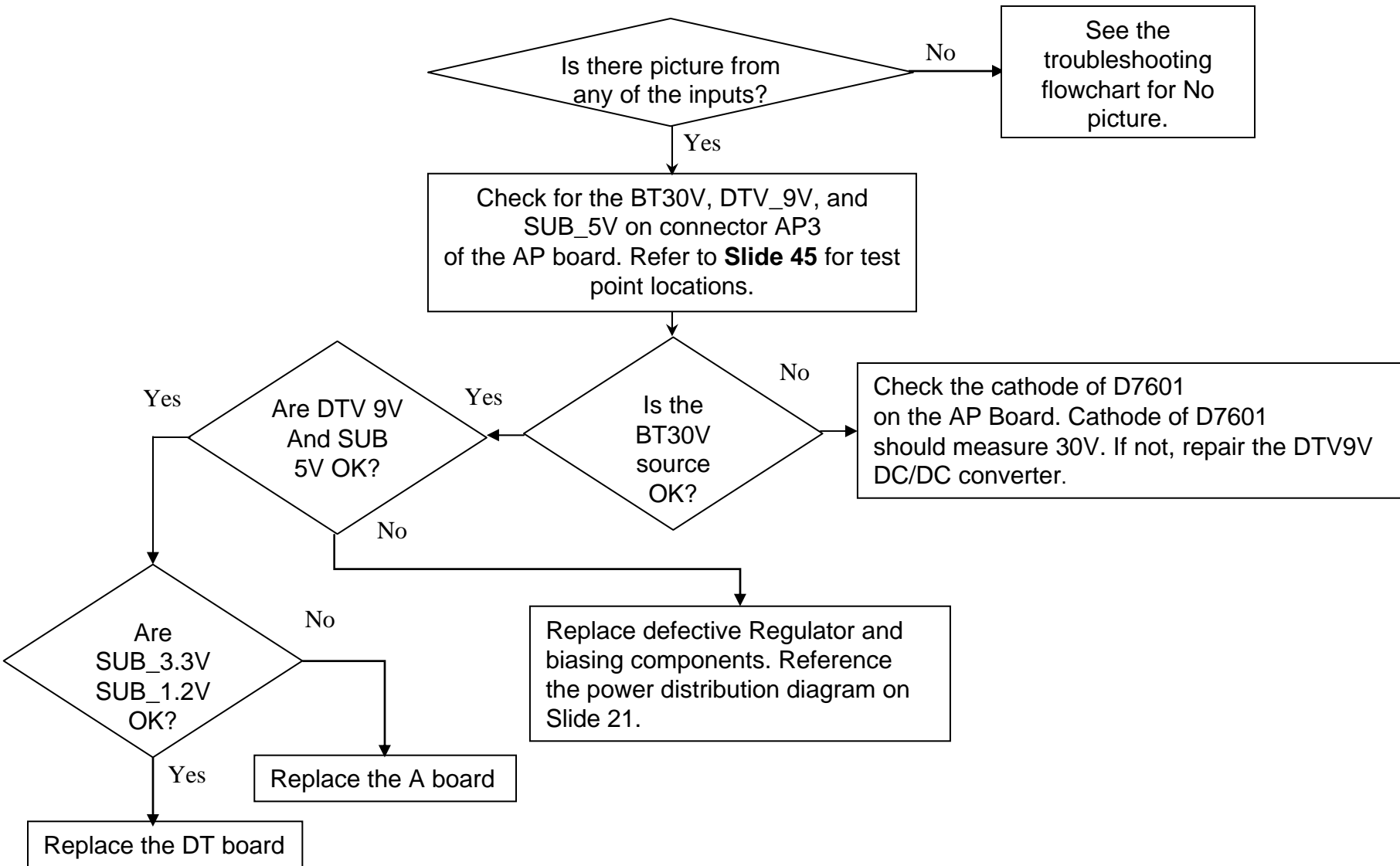

# No Video, Dark Blue Screen

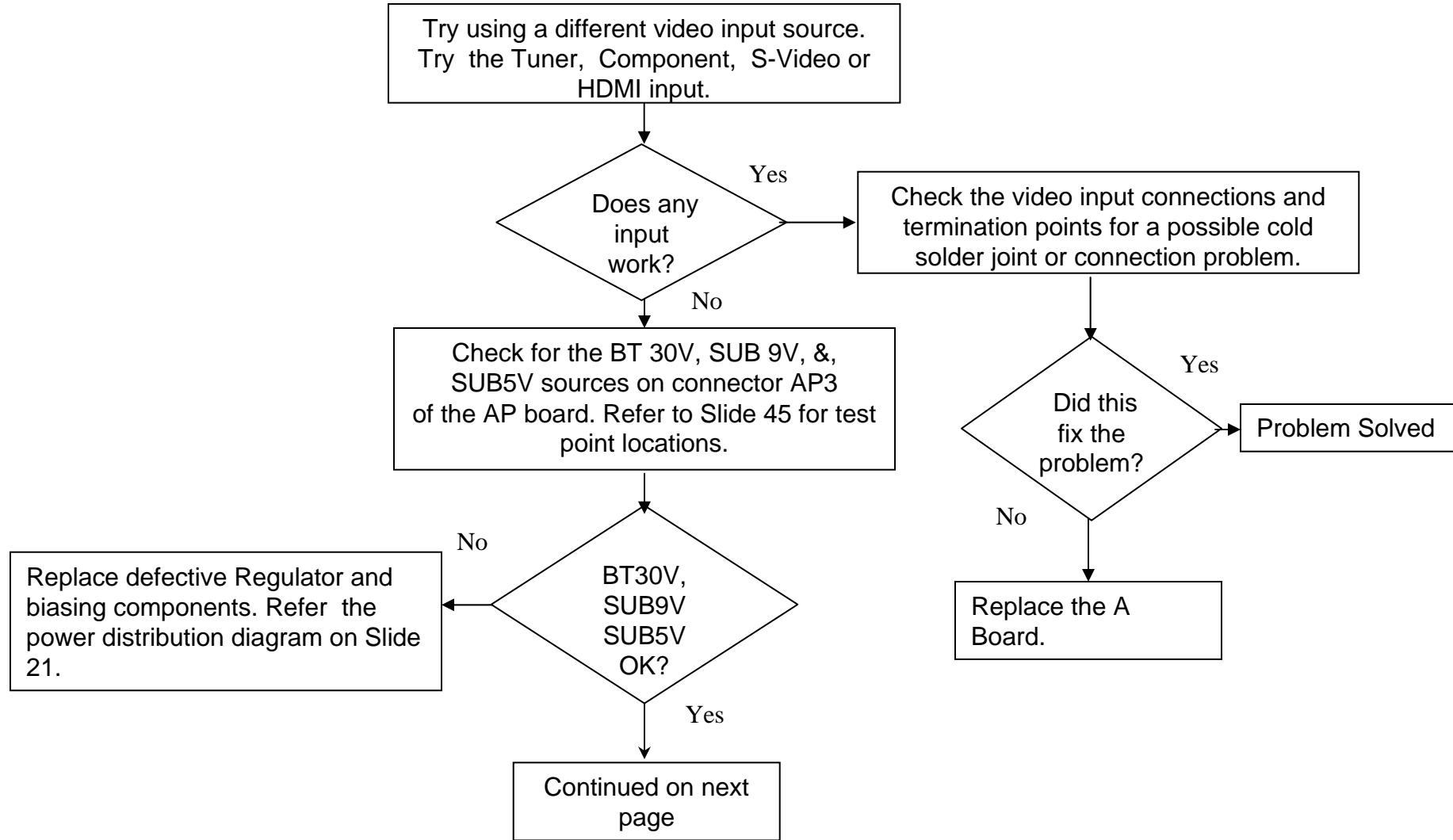

# No Video, Dark Blue Screen (Continued)

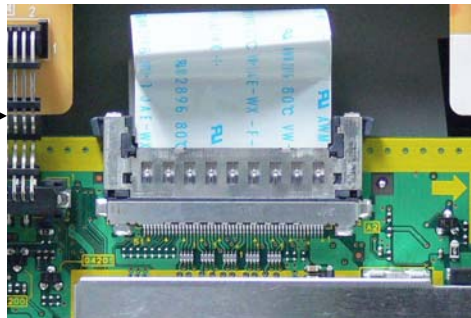
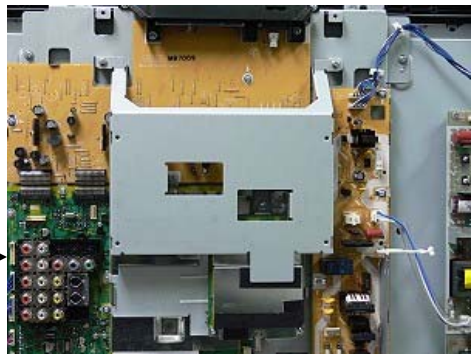
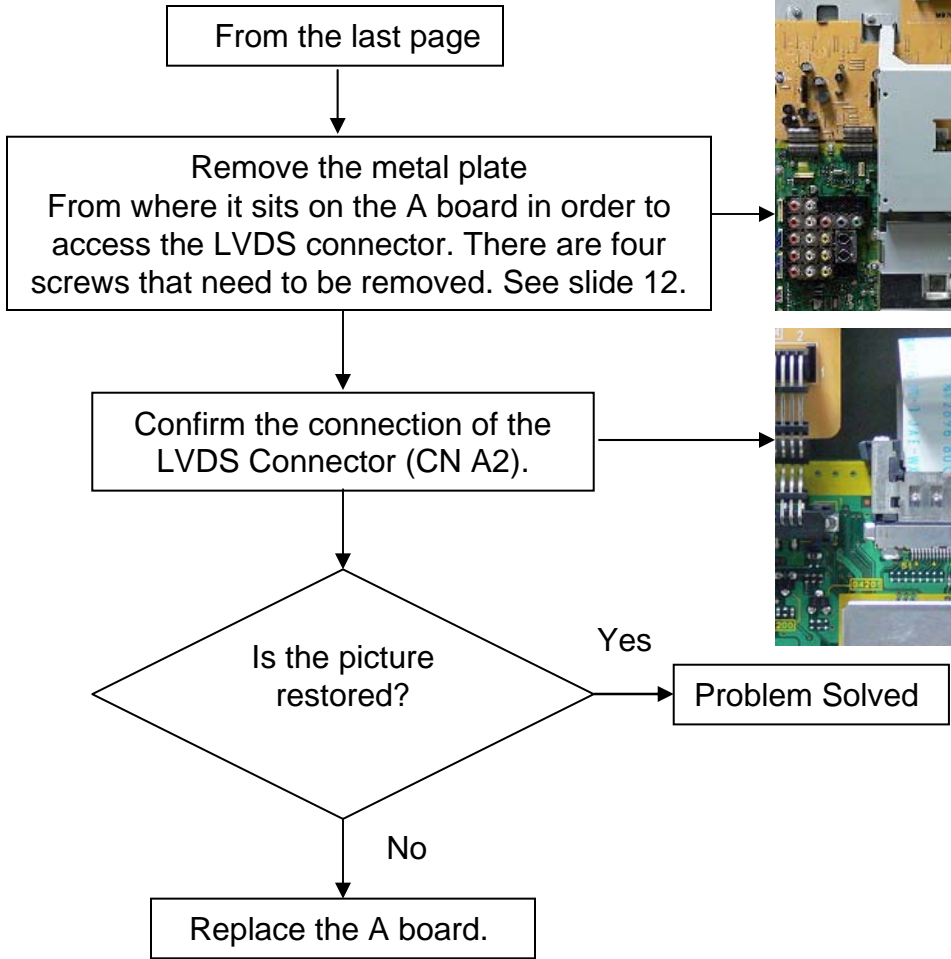

# No Audio

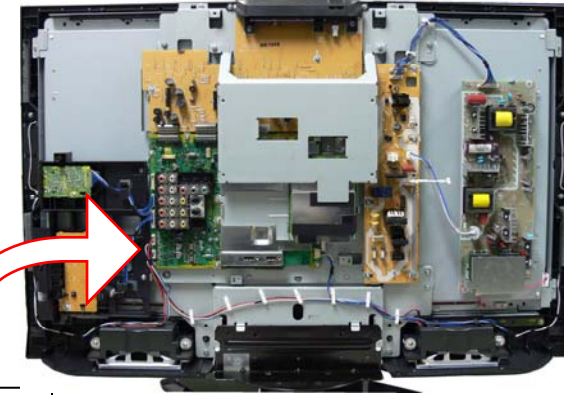
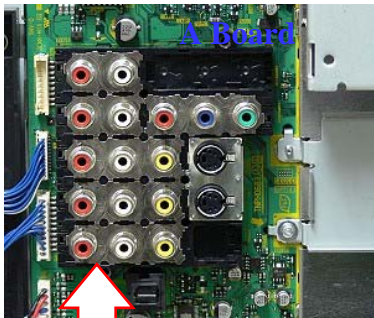

Try using a different audio input source. Try the Tuner, Component, S Video or HDMI input.

Yes

Are other Audio inputs OK ?

No

Determine which audio input is defective. Check for poor solder connections in the vicinity of the audio connection in question.

Check the L/R speaker output connection. Reseat connector A5 and A6.

Yes

Is the Audio ok?

No

Problem Solved

Change the A board.

Yes

Does this fix the Audio problem?

No

Problem Solved

Is there 15V on pins 2 & 3 of connector AP3/A3?

No

Check regulator IC7215 and biasing component on the AP Board. Replace if defective.

Yes

Change the A Board.

# No Power

Refer to the AP Board test points  
Slide 45.

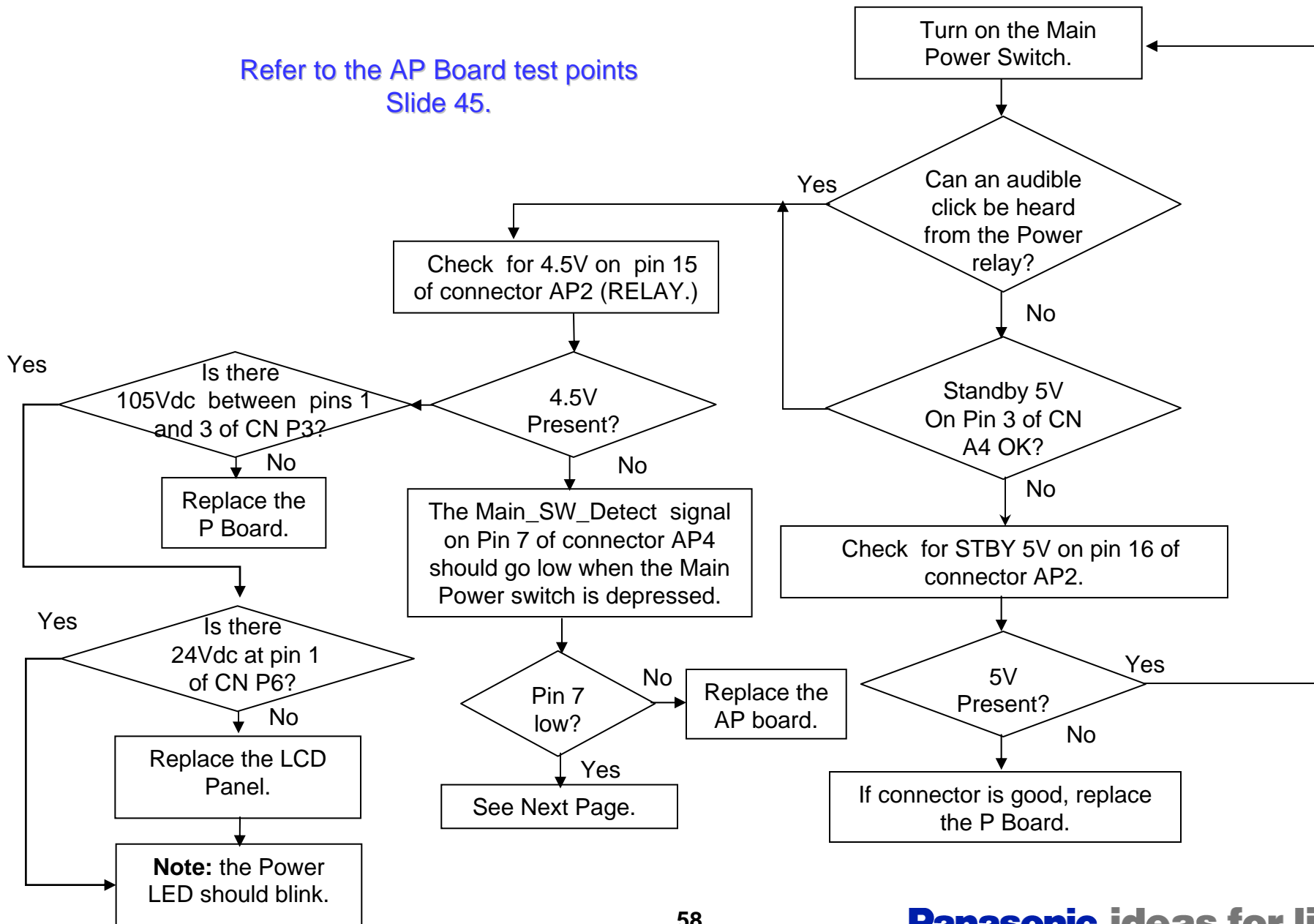



# No Power

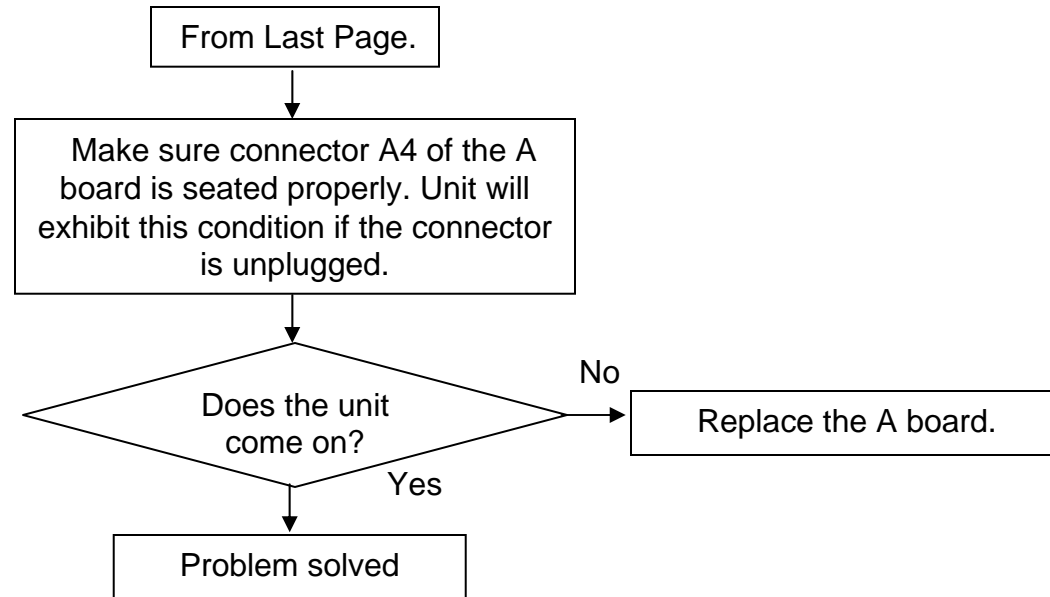

# Power LED Blinks One Time (INV\_SOS)

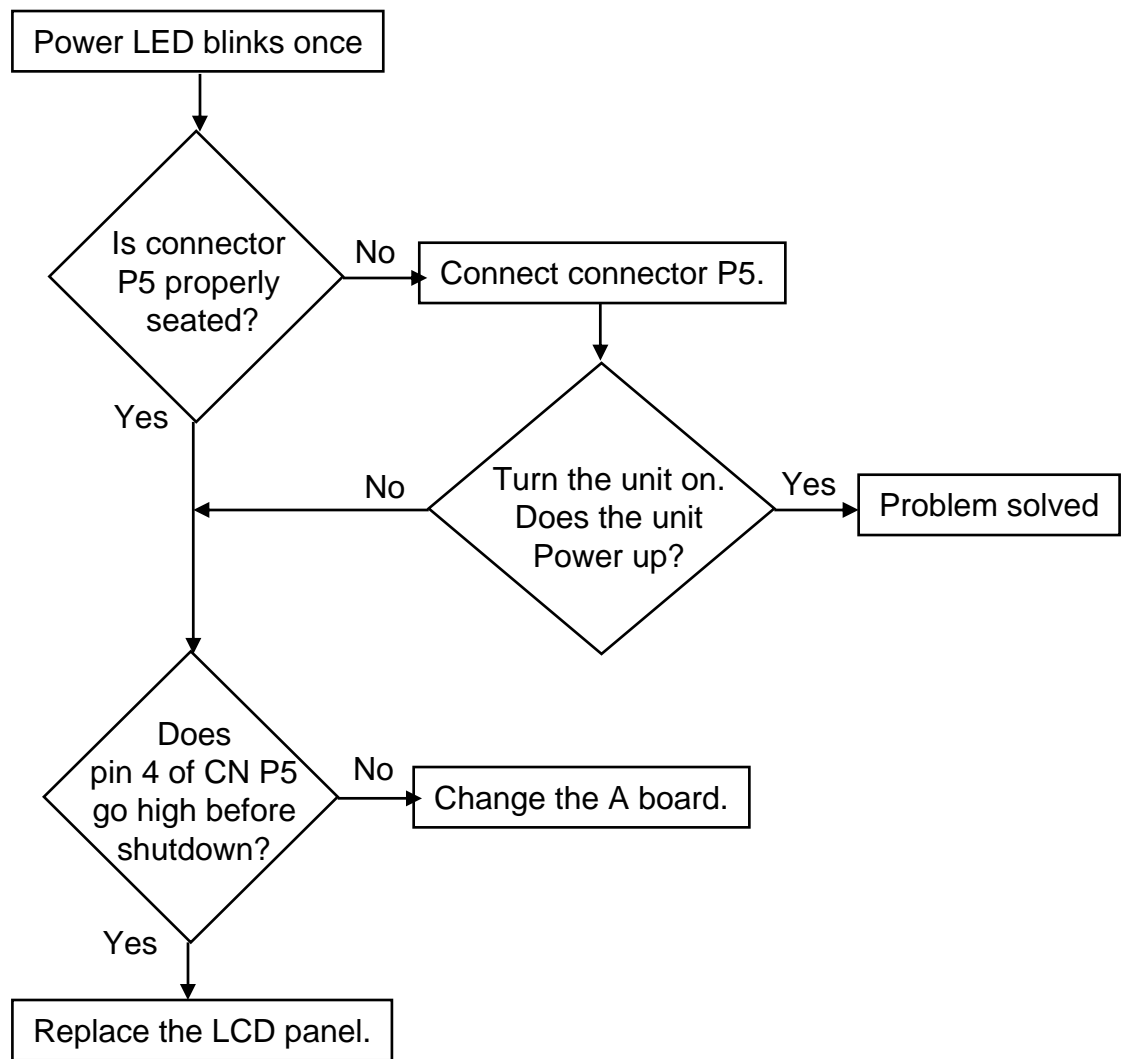

# Power LED Blinks Three Times (TV\_SOS)

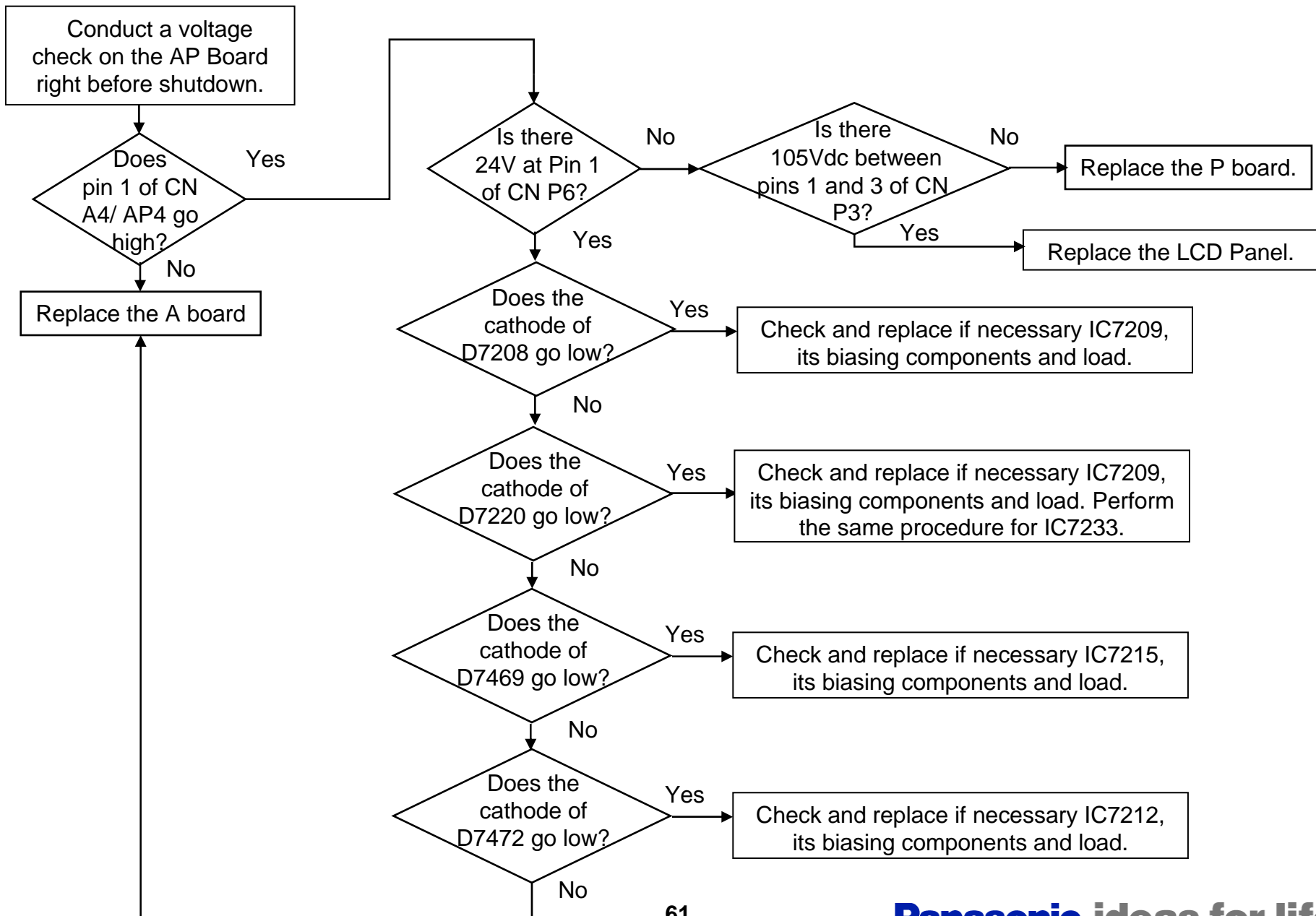

# Power LED Blinks Four Times

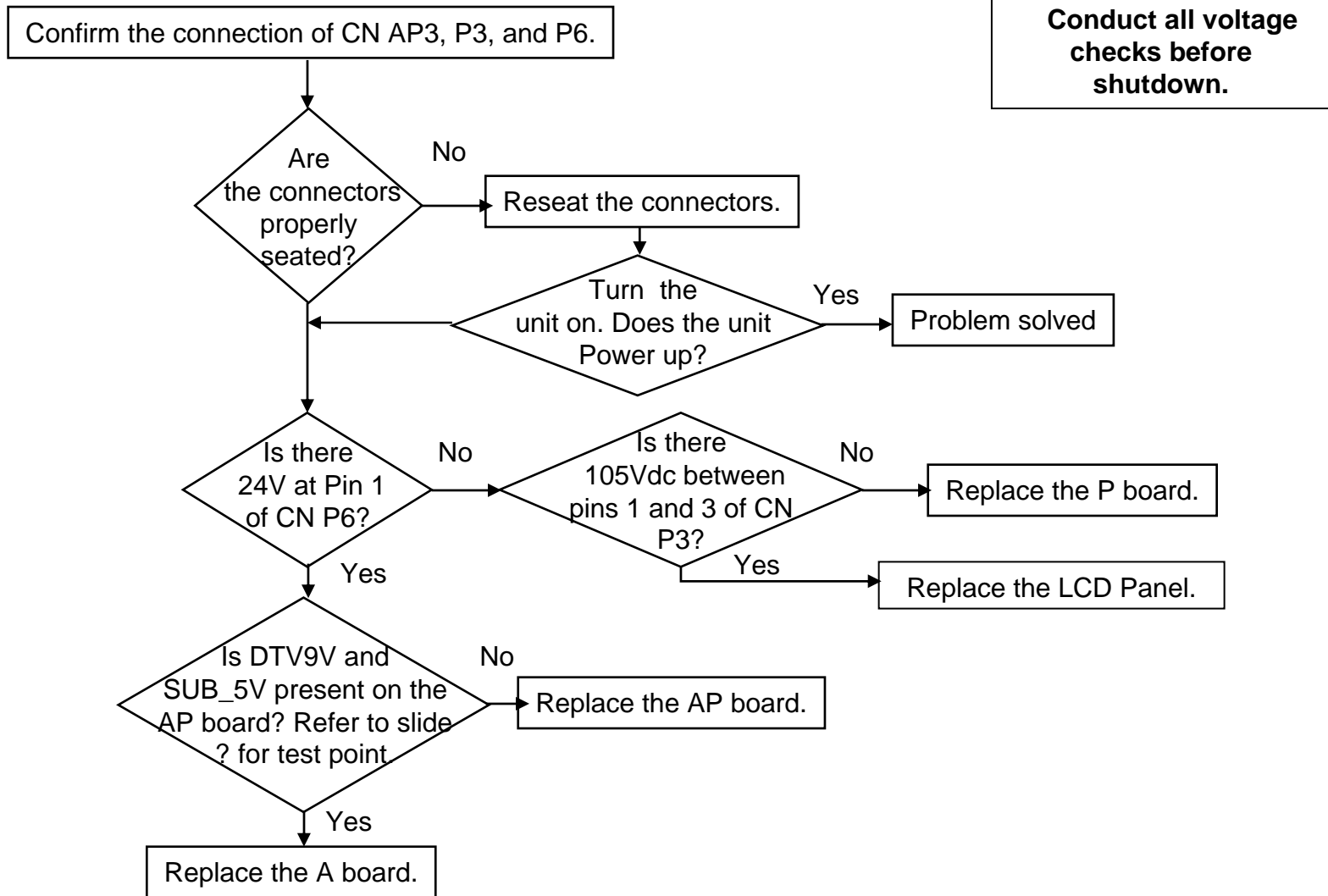

# 2008 LCD Television Models

## Technical Guide

TC-37LZ85U/TC32LX85 LCD Display Television



# Full HD TC-LZ85 & HD TC-LX85 Series

## VIERA Technology for Ultimate Full-HD Picture Quality

- 178° Wide Viewing Angle with IPS Alpha Panel
- 10,000:1 High Contrast with Intelligent Scene Controller
- x.v.Color
- Deep Color (HDMI™ 1.3)

## Other Features For Comfortable TVs Life

- Built-in SD Memory Card Slot with HD Photo Viewer
- Gallery Player® read
- VIERA Link™
- PC Input
- Horizontal Arch Design



**37**

**TC-37LZ85**

**37" Class LCD HDTV**  
(Measured Diagonally)



# Chassis structure (37 Full HD type)

**New**

2007 Model (ex 37LZ700D)

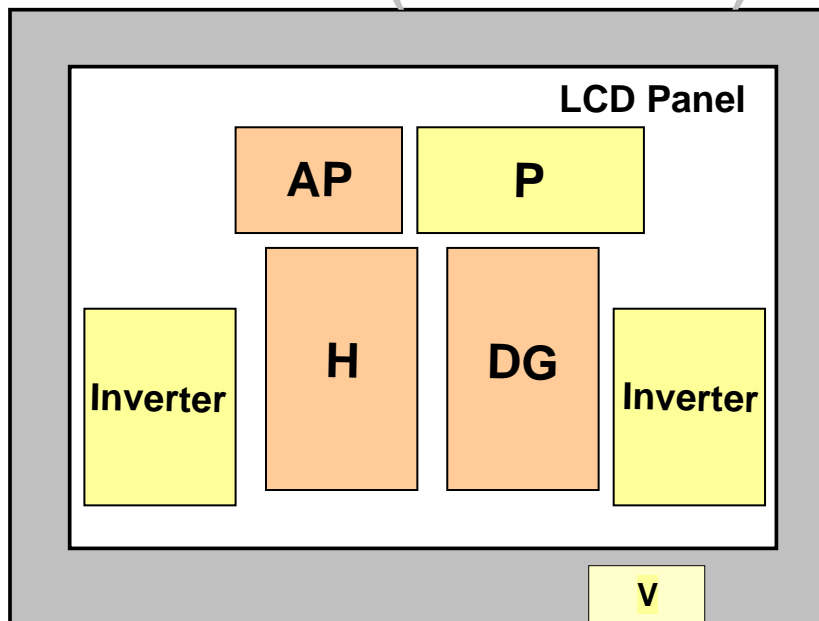

**2008 Model (ex 37LZ85 )**

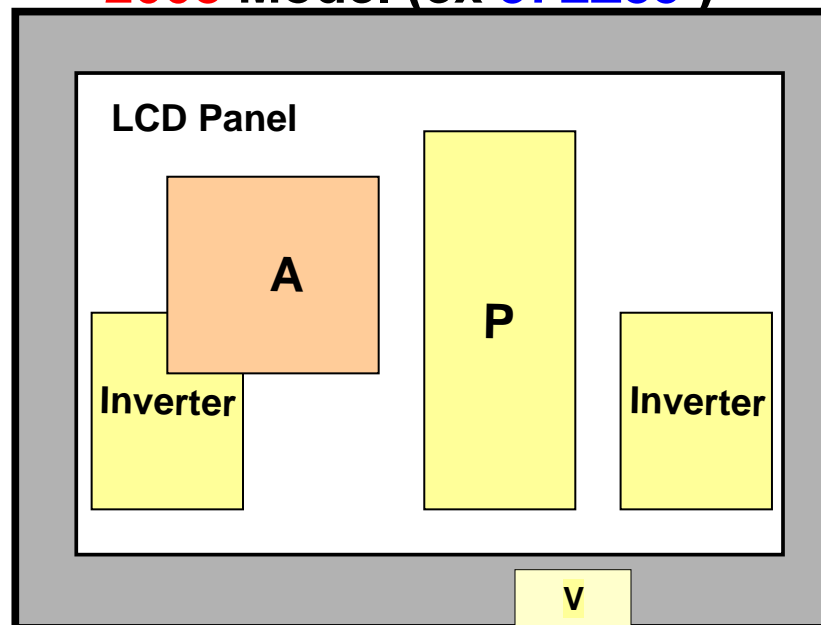

**Notice**

**H and DG boards are integrated to A board**

The H and DG board are integrated to A board of the 2008 model.  
Therefore the Input switch, system control, and signal processing are performed by the A board.  
The AP board is merged with the P board.

# Chassis structure (37 HD type)

**New**

2007 Model (ex 32LX70 series)

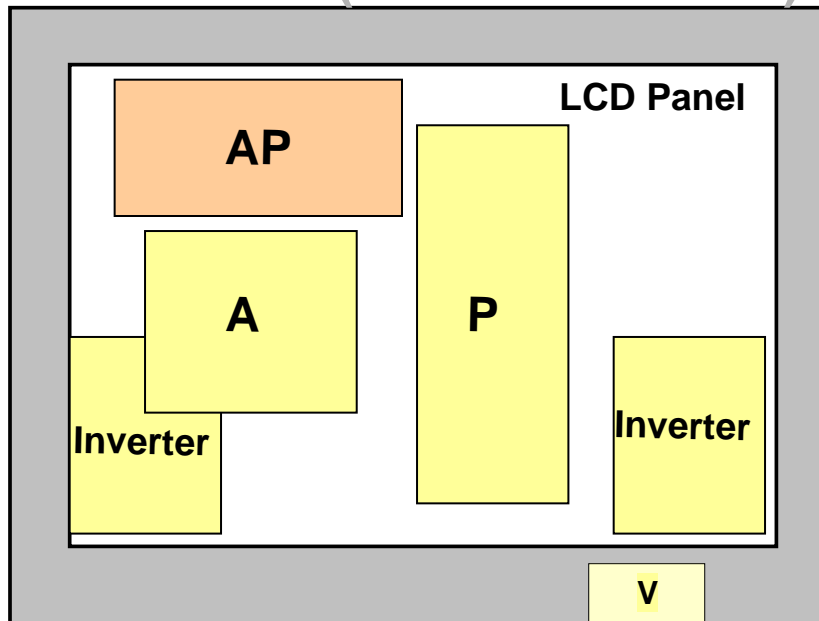

2008 Model (ex 32LX85 series)

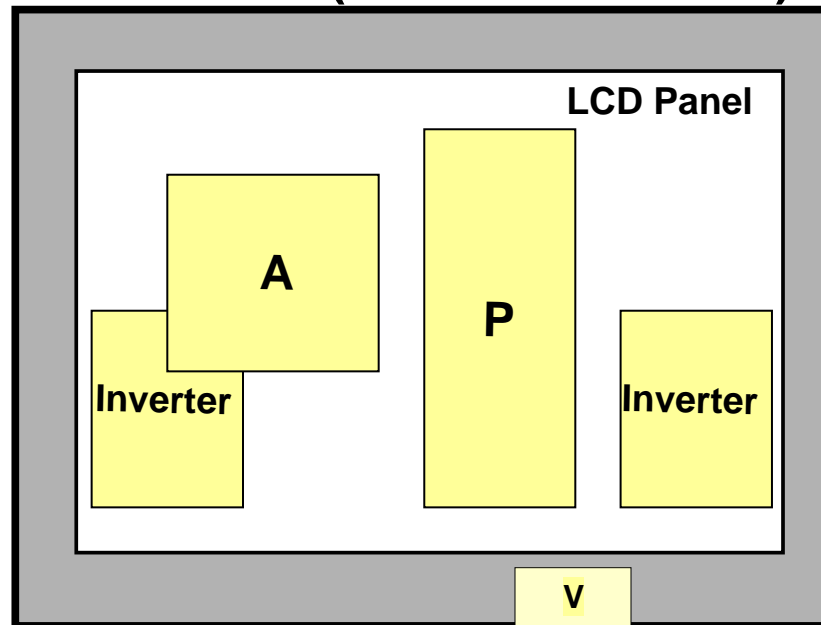

**Notice**

**AP board is now merged with the P board**

The A, P, and V boards are the only printed circuit boards used in the 2008 models.



# Signal Circuit Block Diagram

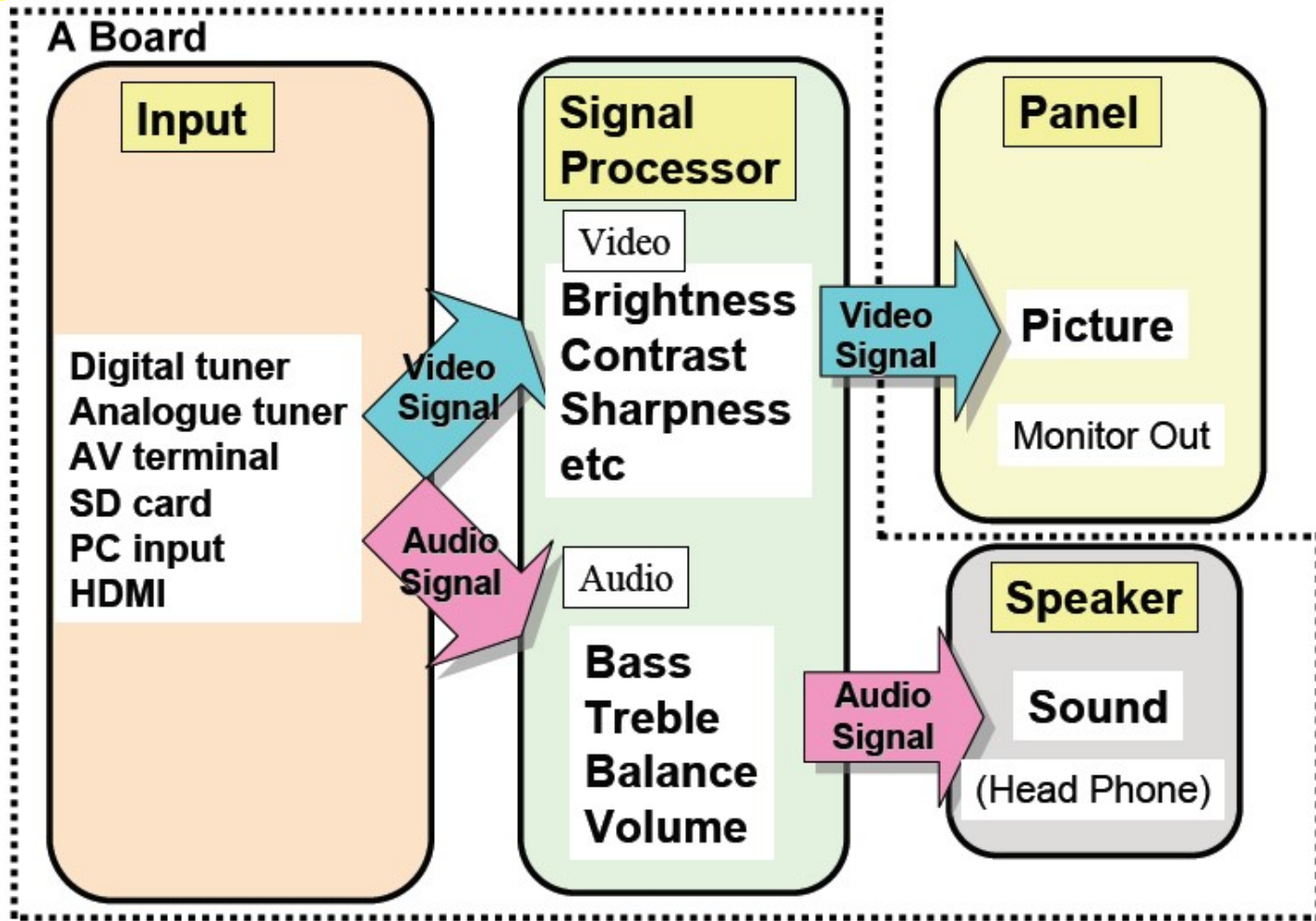

The A board is responsible for video input selection, video processing, and audio processing. The LVDS output signal is provided to the LCD panel for display and the audio signal to the speakers, headphone jack, and optical output jack.

# TC-32LX85 / TC37LZ85 Signal Circuit Block Diagram

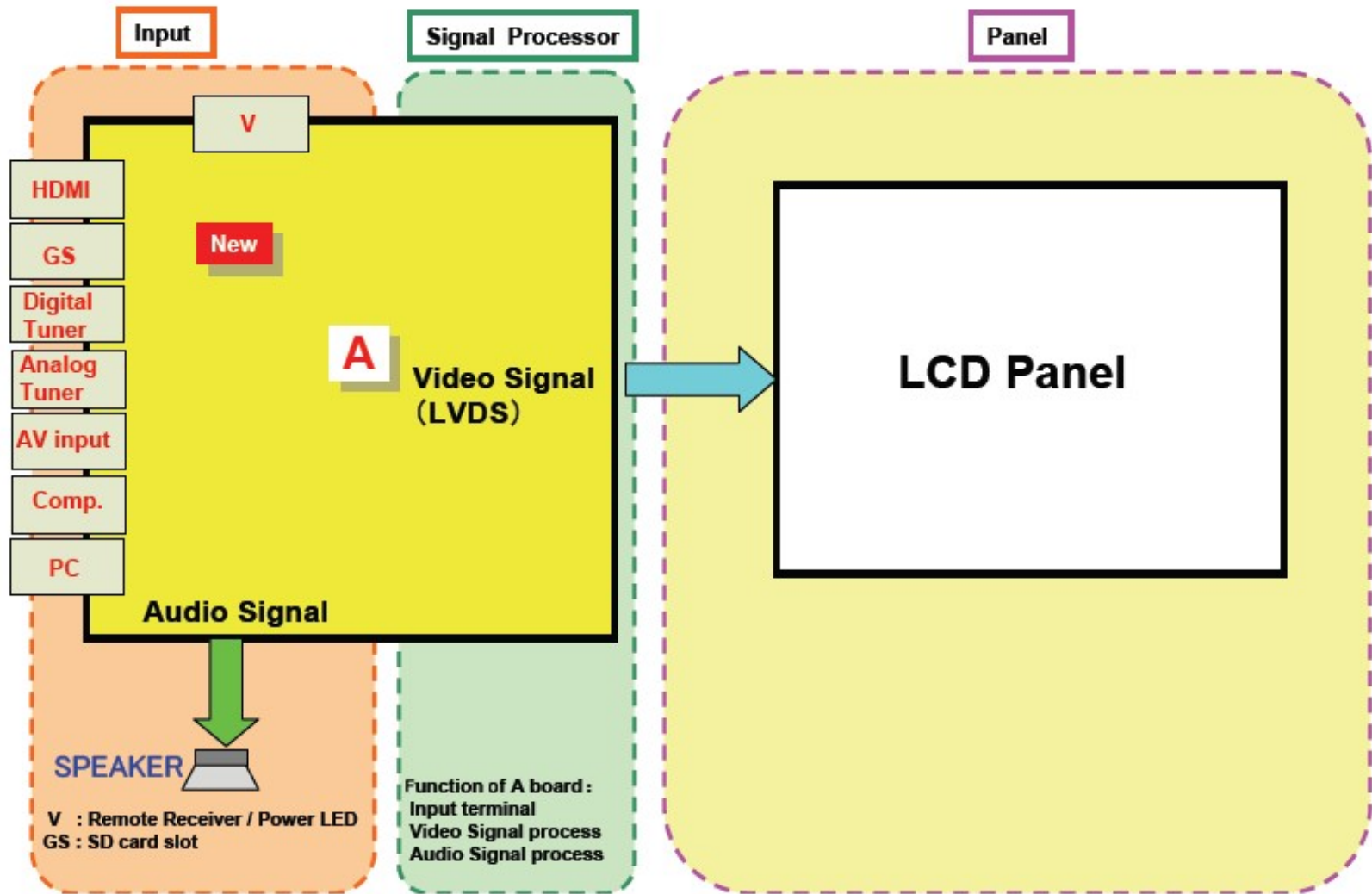

The A board is responsible for video input selection, video processing, and audio processing. The LVDS output signal is provided to the LCD panel for display and the audio signal to the speakers, headphone jack, and optical output jack.

# TC37LZ85 Signal Circuit Block Diagram

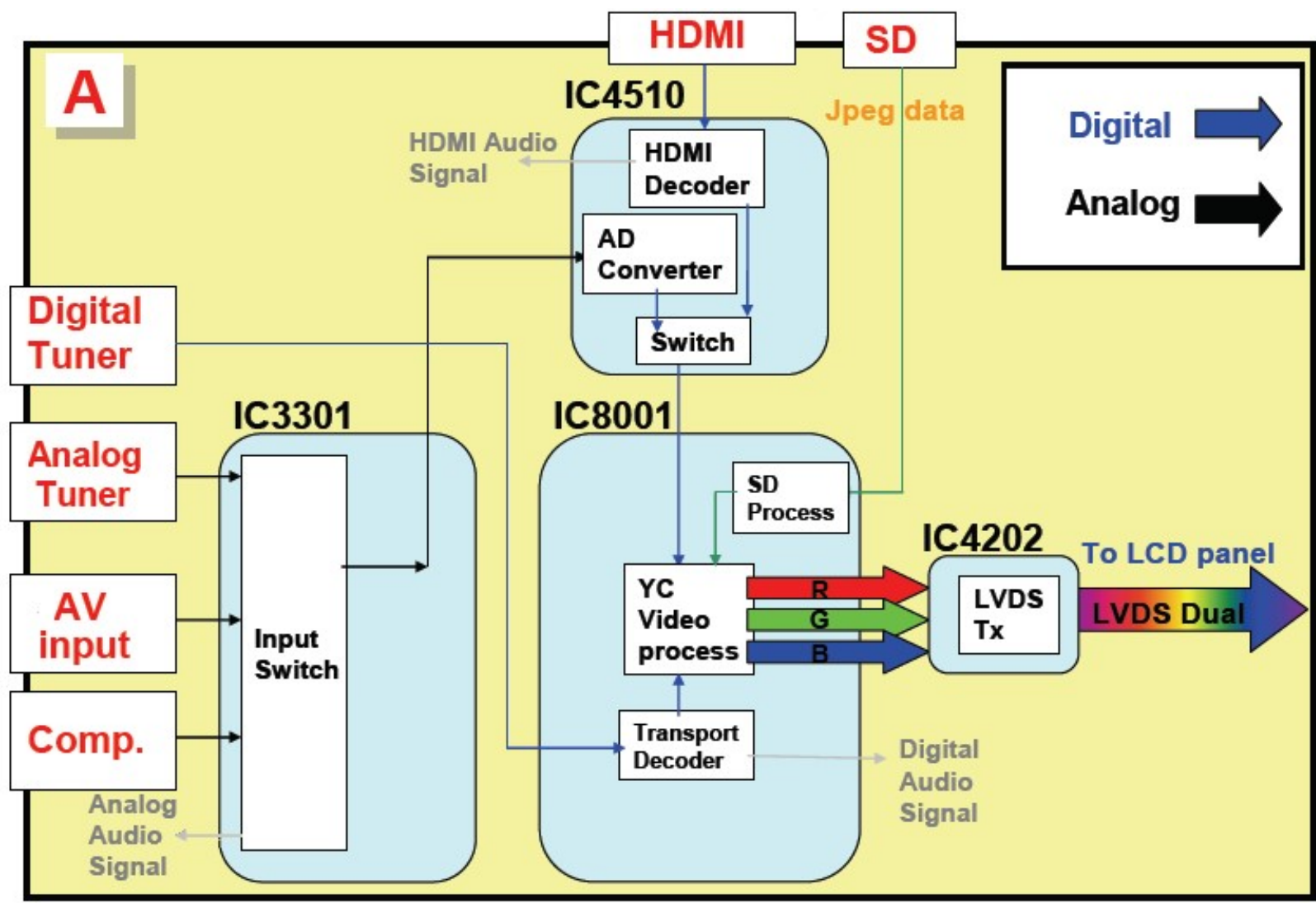

# TC37LZ85 Signal Circuit Block Diagram

The main function of the A board is to select and process incoming video signals. Video inputs, Component Video Input, and the composite video output of the tuner are all connected to IC3301 for selection. The video output signal of the switch can be in any of the three analog formats: Video, Y/C, or Y, Pb, Pr. The selected output enters IC4510, the HDMI I/F Receiver/Decoder IC, for A/D conversion. The 10 bit YUV data is provided to a video switch. The HDMI receiver section of IC4510 converts the incoming HDMI signals to YUV data and outputs to the switch. The output of the switch is provided to the PEAKS LITE IC, IC8001.

Digital television reception of the tuner is output in the form of a transport stream (CHODATA). The transport stream enters the DTV I/F (Interface) section of IC8001 where the video signal is extracted and converted to YUV data. The JPEG data of the GS board enters the JPEG I/F section of IC8001 for conversion into YUV data. The internal video selector of IC8001 (not shown in the diagram) selects and outputs the desired picture data to the Video Process circuit.

The Video Process section of the IC8001 performs all picture control operations such as brightness, contrast, color, tint, etc. On Screen Display data such as channel numbers, Digital TV closed caption, and picture adjustments are mixed with the video data. The output of IC8001 is provided to IC4202, the LVDS transmitter. The transmitter distributes signals with low-jitter, while creating little noise. It reduces power consumption and the generated noise from data transmission. Another benefit of the LVDS standard is minimal concern for cable length. The output of the LVDS transmitter is provided to the LCD for display.

# TC32LX85 Signal Circuit Block Diagram

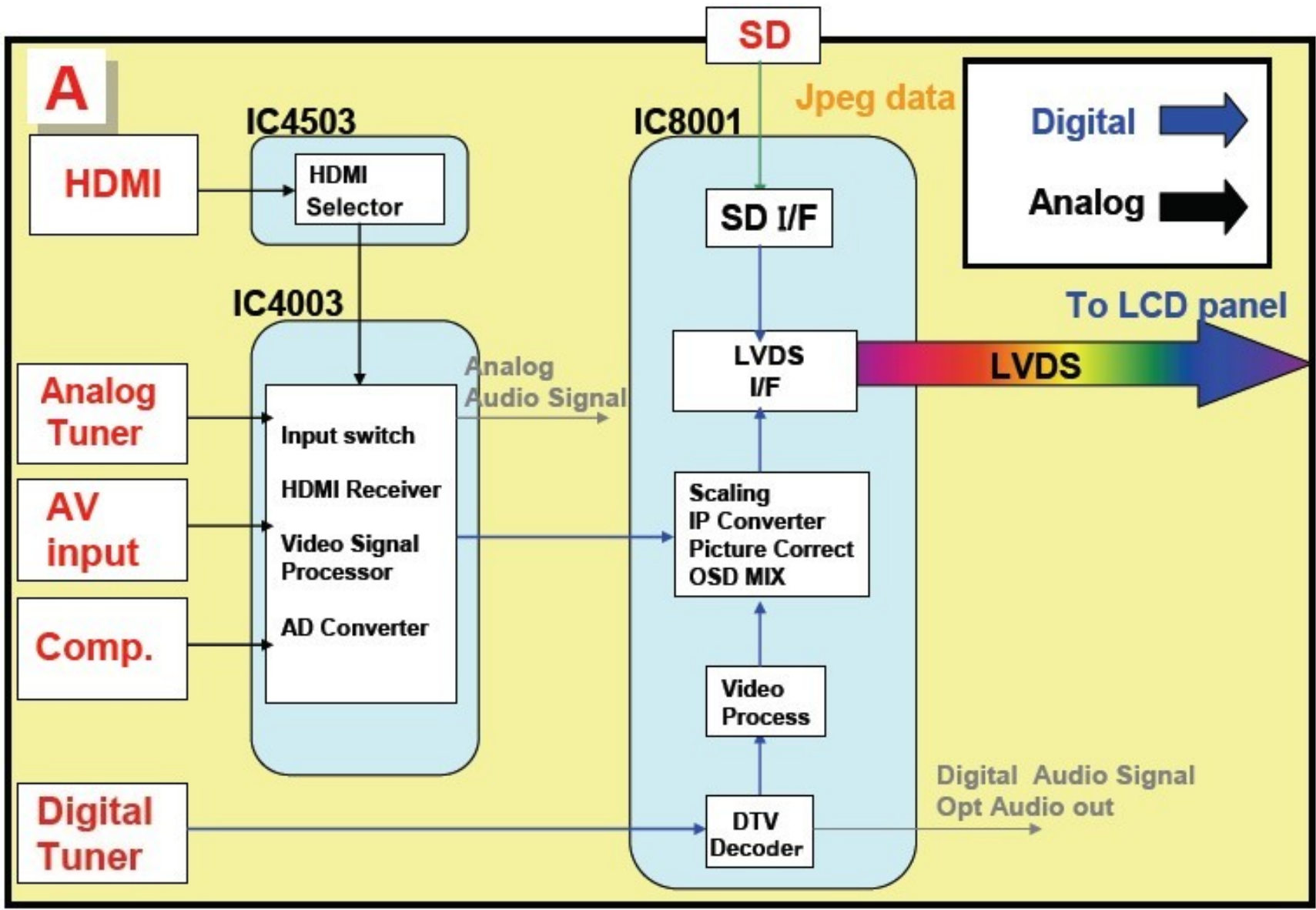

# TC32LX85 Signal Circuit Block Diagram

The main function of the A board is to select and process incoming video signals. The HDMI receiver located inside IC4003 converts the HDMI signal into YUV data. Analog signals such as; Video inputs, component video Input, composite video output of the tuner are all connected to IC4003 for selection. The selected analog signal enters the A/D converter circuit for conversion into YUV data. An internal switch of IC4003 selects the desired signal and outputs to the PEAKS LITE IC, IC8001.

Digital television reception of the tuner is output in the form of a transport stream (CHODATA). The transport stream enters the DTV decoder section of IC8001 where the video signal is extracted and converted to YUV data. The JPEG data of the GS board enters the SD/IF section of IC8001 for conversion into YUV data. The internal video selector of IC8001 (not shown in the diagram) selects and outputs the desired picture data to the Video Process circuit.

The Video Process section of the IC8001 performs all picture control operations such as brightness, contrast, color, tint, etc. On Screen Display data such as channel numbers, Digital TV closed caption, and picture adjustments are mixed with the video data. The RGB output of the video process section of the IC undergoes conversion to a LVDS signal before being output to the LCD panel for display.



# TC37LZ85 Audio Circuit Block Diagram

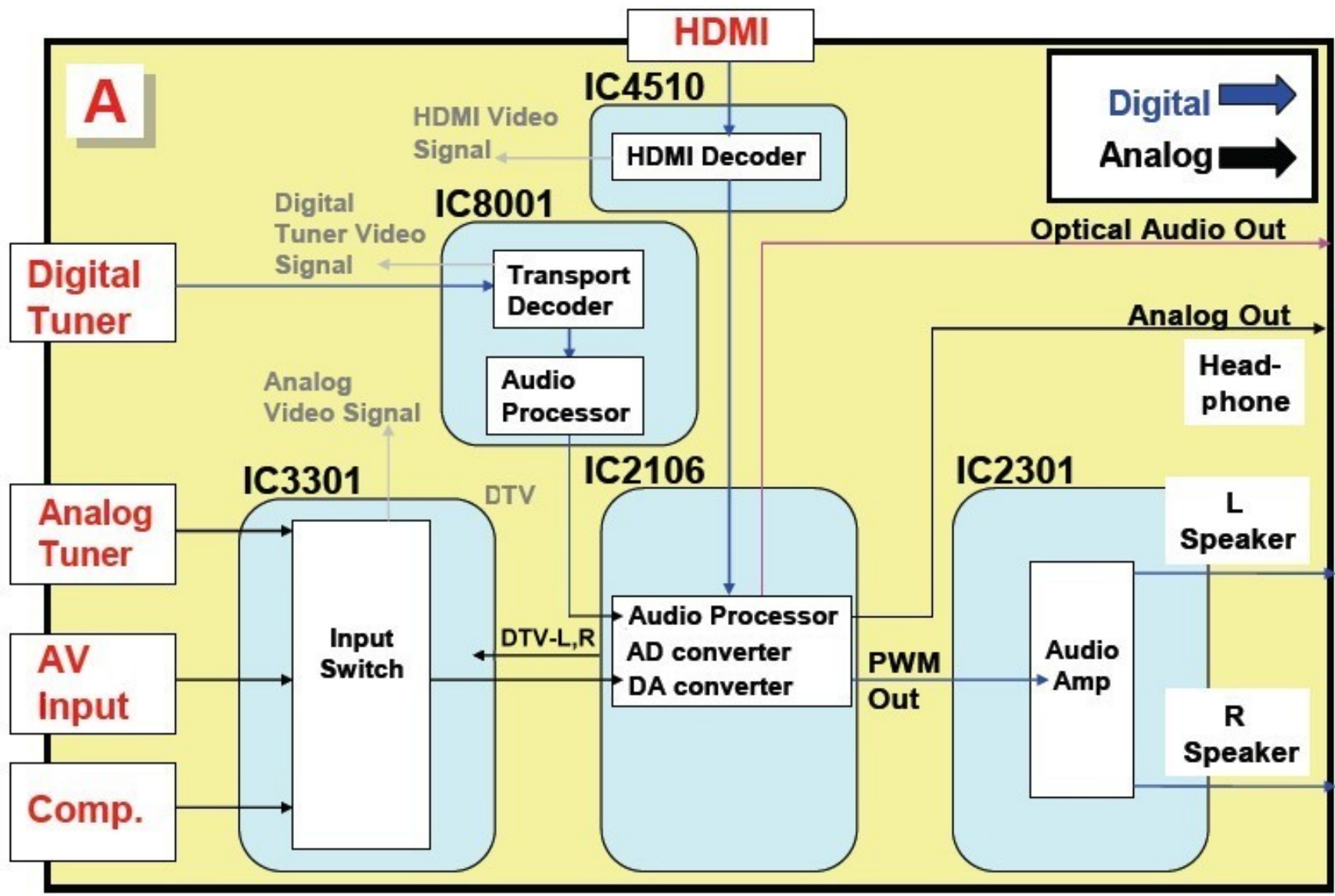

# TC37LZ85 Audio Circuit Block Diagram

IC3301 of the A board handles the audio selection of most inputs. Analog audio of the tuner and audio signals from composite, component, and DVI inputs are connected to IC3301 for selection. The output of IC3301 enters IC2106 and undergoes analog to digital conversion.

IC4510 converts the incoming HDMI audio into serial data and outputs to IC2106. Digital television reception of the tuner is output in the form of a transport stream that contains MPEG2 video and AC3 audio. The transport stream enters the DTV decoder section of IC8001 where the audio signal is extracted and converted to serial data. The DTV audio data is output to the audio DSP (Digital Signal Processor) IC2106 for processing.

The DSP IC2106 provides three audio outputs. One output is either AC3 or PWM audio connected to the digital audio output jack. A second output is analog audio provided to the headphone jack. The third output is adjusted for volume, bass, treble, and balance and then output as PWM data to the audio amplifier IC2301. The amplified two channel PWM data is output to the right and left channel speakers for sound reproduction.



# TC32LX85 Audio Circuit Block Diagram

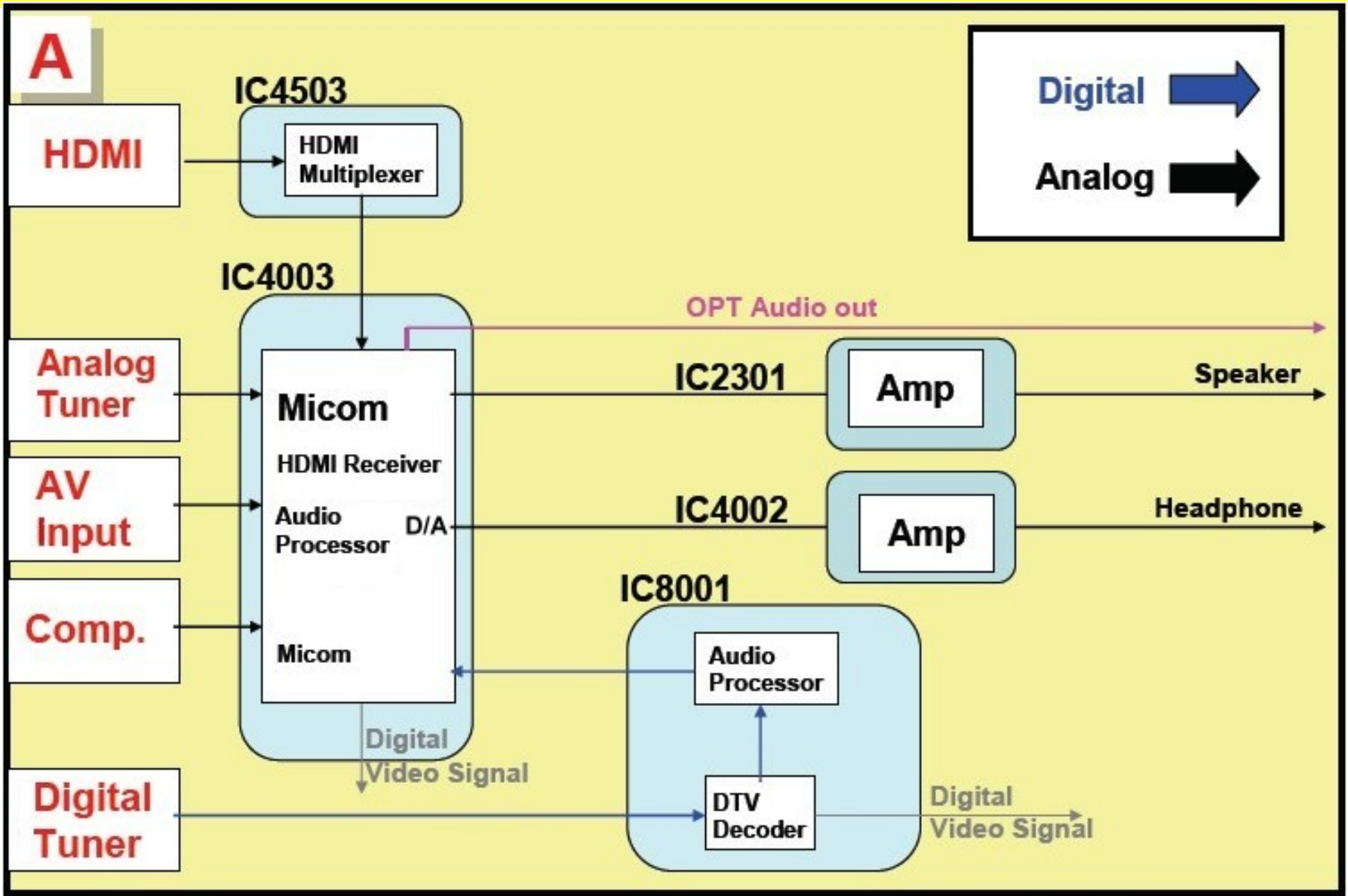

# TC32LX85 Audio Circuit Block Diagram

IC4003 of the A board handles the audio process of all inputs. Analog audio of the tuner and audio signals from composite, component, and DVI inputs are connected to IC4003 for selection and process..

IC4503 converts the incoming HDMI audio into serial data and outputs to IC4003. Digital television reception of the tuner is output in the form of a transport stream that contains MPEG2 video and AC3 audio. The transport stream enters the DTV decoder section of IC8001 where the audio signal is extracted and converted to serial data. The DTV audio data is then output to IC4003 for processing.

IC4003 provides three audio outputs. One output is either AC3 or PWM audio connected to the digital audio output jack. A second output is analog audio provided to IC4002 for amplification and then the headphone jack. The third output is adjusted for volume, bass, treble, and balance and then output as PWM data to the audio amplifier IC2301. The amplified two channel PWM data is output to the right and left channel speakers for sound reproduction.

# Power Supply Overview

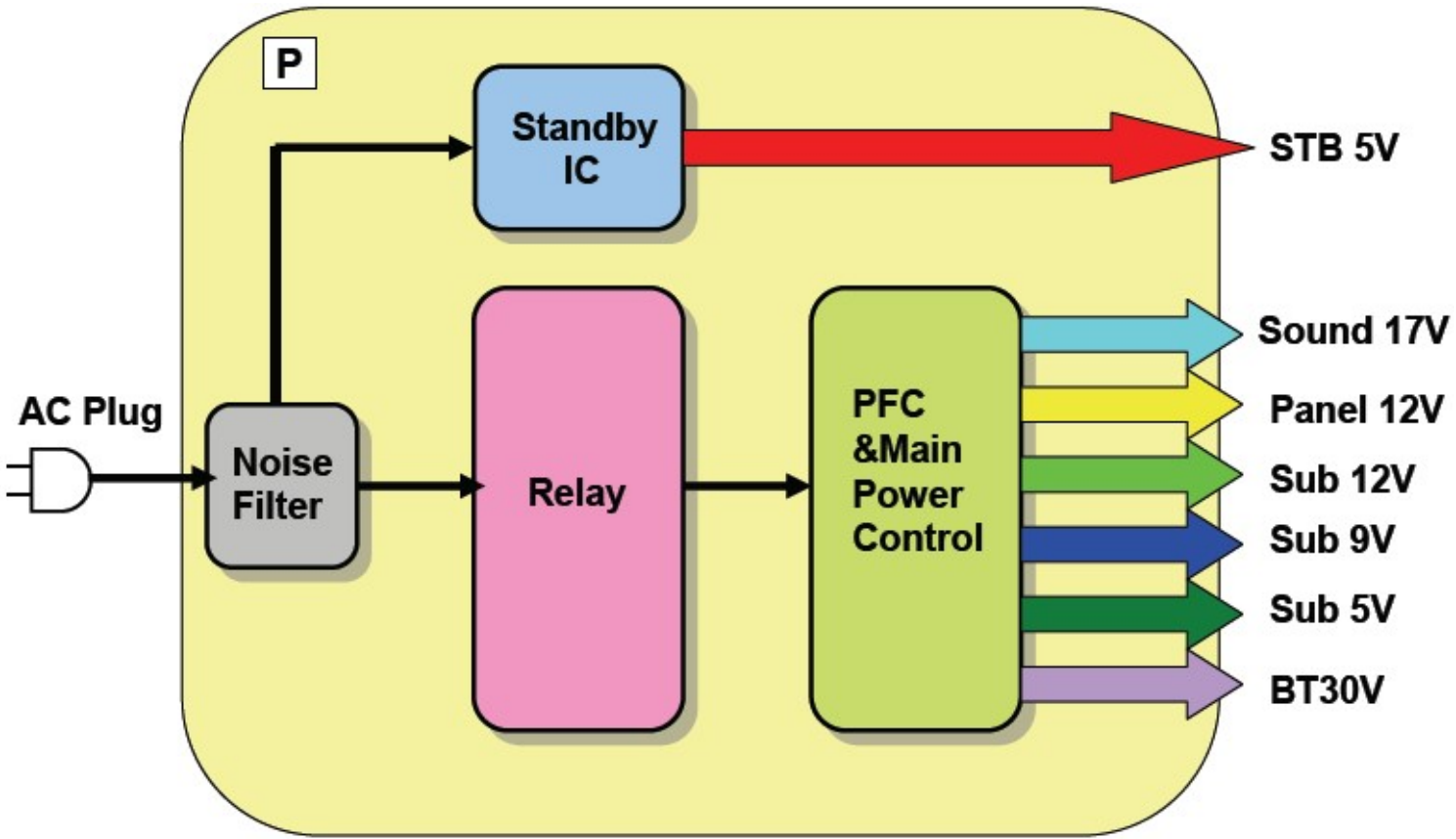

# TC-37LZ85 Power Supply Description

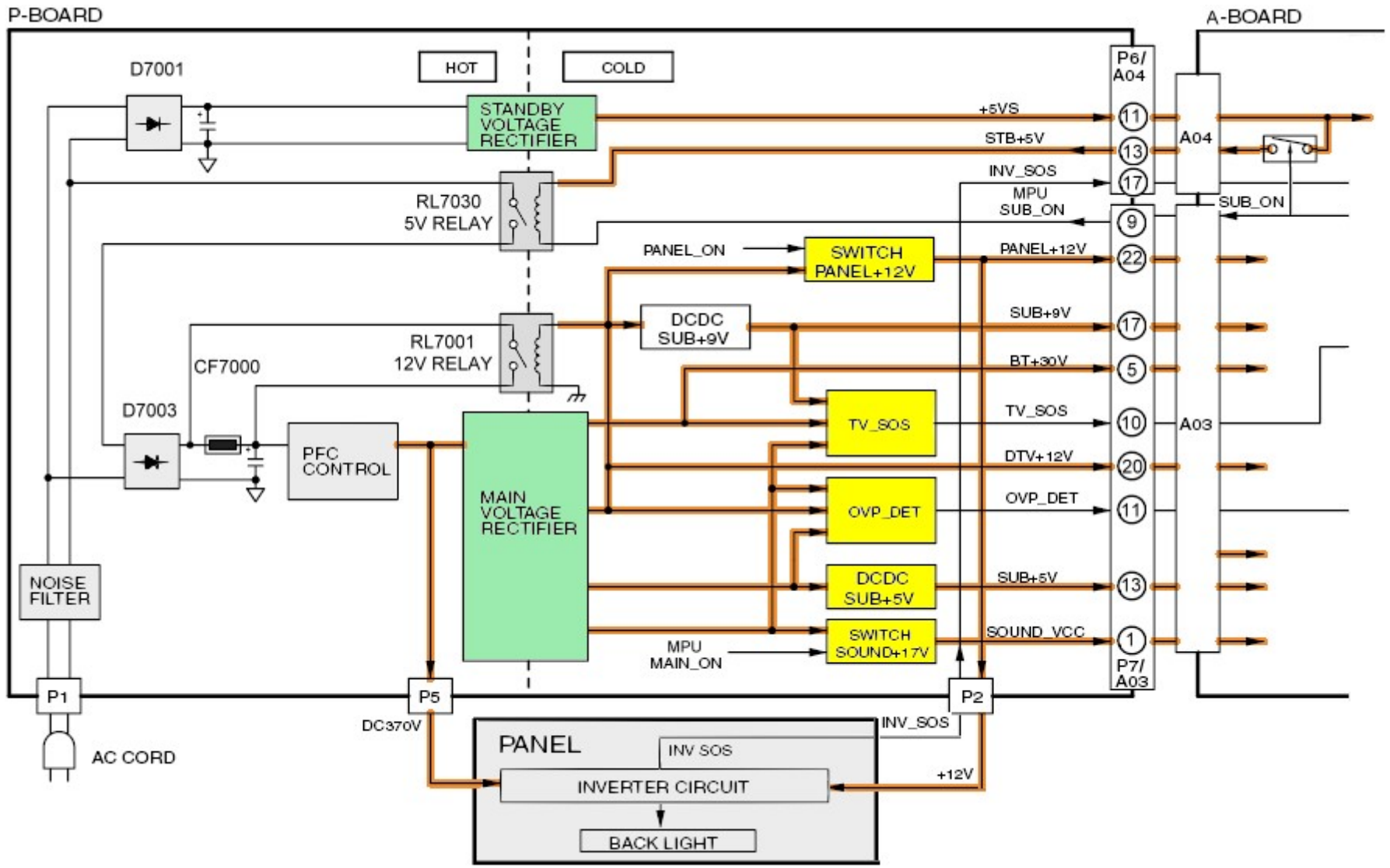

# TC-37LZ85 Power Supply Description

When AC is applied to the TV, the Standby circuit of the P board outputs STB5V to the A board. On the A board The STB5V is converted to 3.3V to power the system control circuit (not shown in the diagram) for standby operation. The STB3.3V is also applied to the Remote Control receiver and the power LED on the V board. The MCU (IC1100) of the A board outputs the SUB\_ON command to provide a ground connection to relay RL802 of the power supply board. On the A board, the SUB\_ON command is used to turn on a switch that provides STB5V to relay RL802 via pin 13 of connector A04/P6. When the relay is closed, 370Vdc from the PFC (Power Factor Control) is supplied to the LCD panel for conversion into 120AC. The 370Vdc of the PFC is also provided to the switch mode power supply for conversion into Sub+9V, BT+30V, DTV+12V, SUB+5V.

If the power button (main unit or remote control) is not pressed within 15 seconds after applying AC to the unit, the SUB\_ON command goes low to disengage the power relay. As a result, only STB+5V is output to power the system control circuit of the a board.

When the power button is pressed, the SUB\_ON command goes high to repeat the same operation. The voltages remain present until the unit is turned off. The MCU also provides the Panel\_ON command to trigger the output of PANEL+12V. This voltage is used to turn on the inverter PCBs for the production of 120VAC used to illuminate the backlights of the LCD panel. The PANEL+12V is also used to operate the drive circuits of the LCD panel. The MCU also outputs the Main\_ON command to trigger the output of the SOUND+17V source.

When the power supply output is too high, an over-voltage detection circuit outputs a high to the A board to trigger the shutdown of the unit. The power LED does not blink.

An over-current detection circuit on the power supply board monitors for short circuits. If a detection is made, a high is output to IC1100 to shut down the unit and provide 3 blinks of the power LED.

**Caution:** The P board is to be exchanged only.

# Self-Check and Reset Function

This is the **Self-Check** diagnosis function.

37LZ85 series

32LX85 series

## How to access

### Self-check indication only

- Press the “VOL -” button on the TV and press the “OK” button on the remote control for 3 seconds or more.

### Self-check indication and forced to factory shipment setting (Reset)

- Press the “VOL -” button on the TV and press the “MENU” button on the remote control for 3 seconds or more.

## How to exit

- Unplug the unit from the AC outlet.

**NG** indicates a defective part.  
When NG is displayed, please replace the board.

All parts are located on the A board.

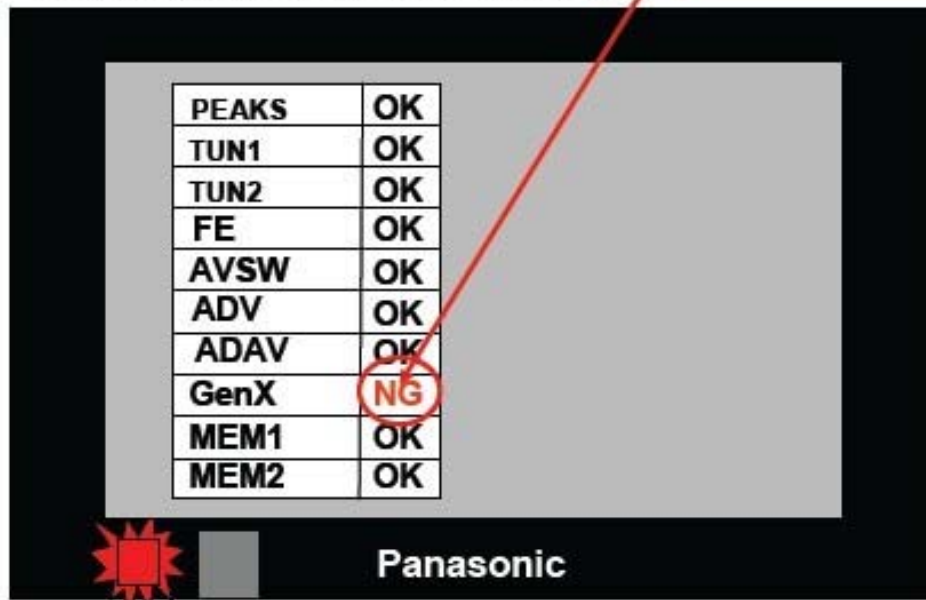

Display	Ref. No.	Description
PEAKS	IC8001	PEAKS
TUN1	TU8300	Tuner PLL Block
TUN2	TU8300	Tuner MTS Block
FE	IC8300	Digital Demodulator
AVSW	IC3001	Audio/video SW
ADV	IC4510	AD converter HDMI RX
ADAV	IC2106	Audio DSP
GenX	IC1100	Stand by Micom
MEM1	IC1101	EPROM(GenX5)
MEM2	IC8503	EPROM(Peaks)



# SOS and Power LED Indication



Blinking times	Contents	Check point
1	Inverter	LCD panel
3	SUB9V, SUB18V short, BT30V voltage down	A board P board
4	DT12V	A board P board
5	SUB 9V down	A board
6	Sub 5V down	A board P board
7	Sub 3.3V down	A board
8	Main 3.3V down	A board
9	Audio output trouble	A board P board
13	Communication Error	A board

Example of the power LED blinking 3 times



# Power LED Blinks 1 Time

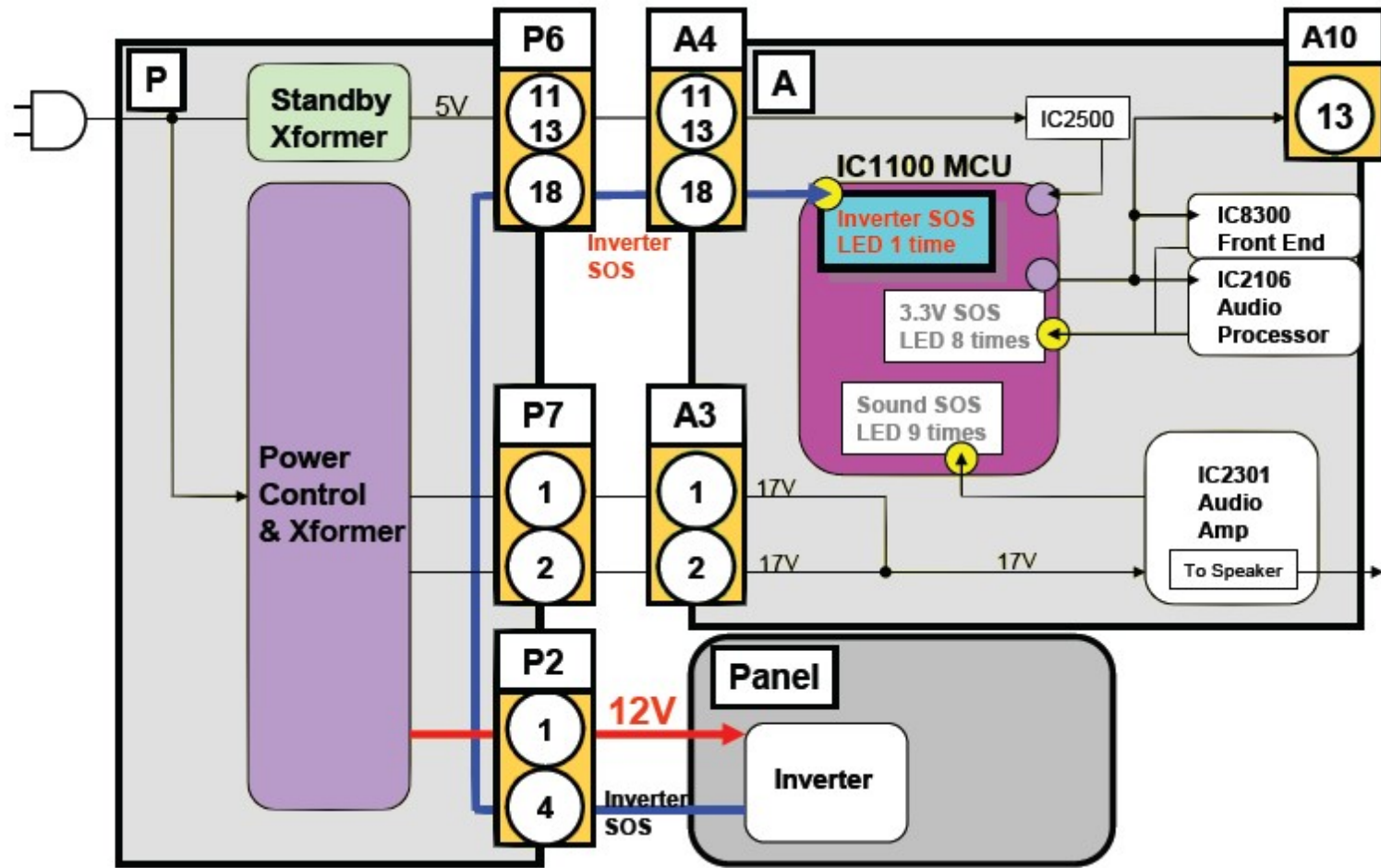

Pin 4 of connector P2 should toggle low after the backlights of the LCD panel turn on. If the backlights do not come on or pin 4 of CN P2 does not toggle low, Reseat the connectors A4, P6, and P2. Confirm the presence of 370Vdc at pin 1 of connector P5 and 12V at pin 1 of connector P2 before replacing the LCD panel.



# Power LED Blinks 3 Times

SUB9V, SOUND17V short, BT30V voltage down

37LZ85 series

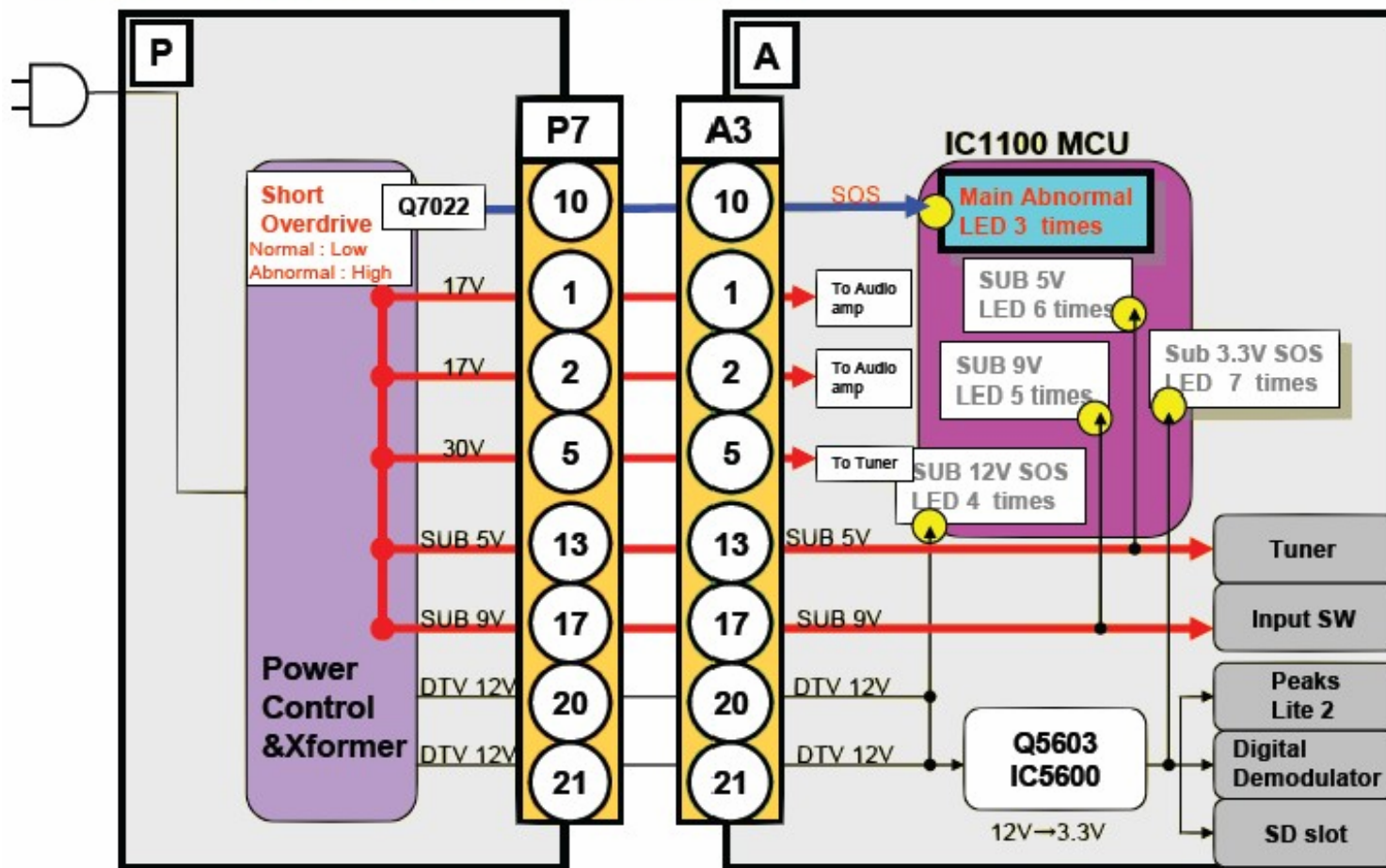

Pin 10 of connector P7/A3 outputs a high when an over-current condition is detected. On the power supply board, locate the test points for the SUB9V, SOUND17V and BT30V. Using an ohmmeter, determine if there is a short between each of the test-point and ground. If a test-point is shorted, disconnect the connector P7 or A3 to isolate the short to either the A or P board.

# Power LED Blinks 4 or 5 Times

4 Blinks: DTV 12V

5 Blinks: SUB 9V down

37LZ85 series

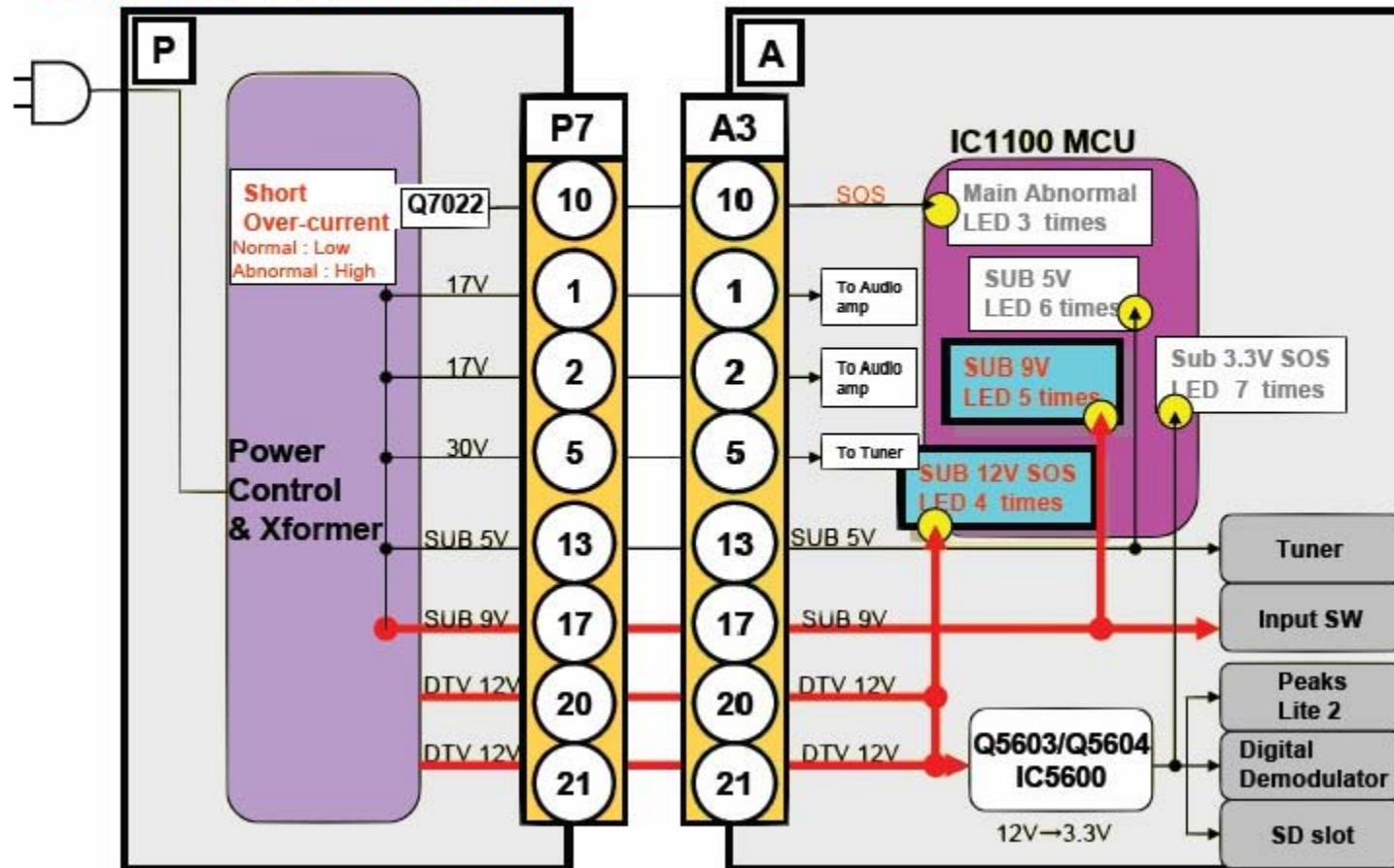

The DTV12V and SUB9V lines are monitored by the MCU. If the voltage corresponding to the number of blinks is missing or shorted, the MCU shuts down the unit and blinks the Power LED. Reseat the connectors P7 and A3 and turn on the unit. If the shutdown persists, use a voltmeter to measure the voltage. If it is present, replace the A board. If it is absent, use an ohmmeter to determine if there is a short to ground. When a short is detected, disconnect the connector P7 or A3 to isolate the short to either the A or P board.

# Power LED Blinks 6 or 7 Times

6 Blinks: SUB5V

7 Blinks: SUB 3.3V

37LZ85 series

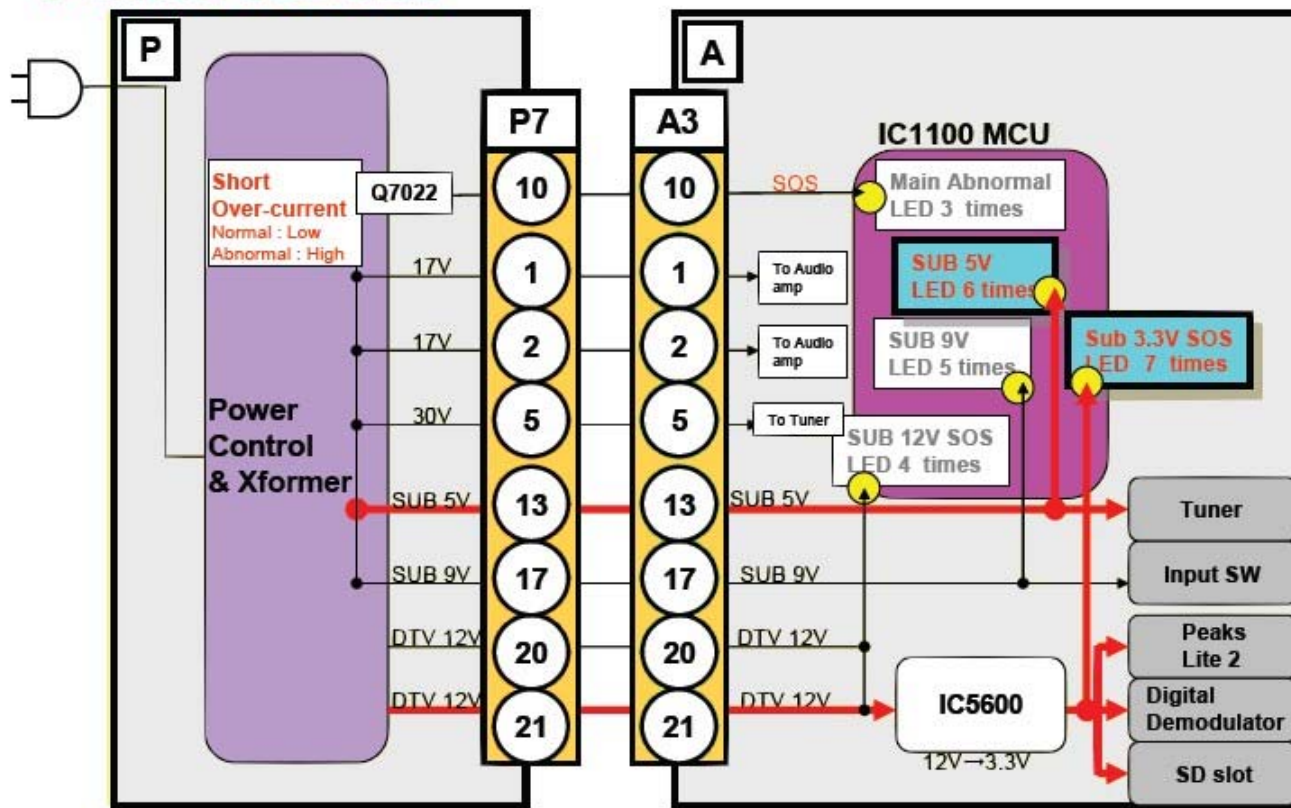

The SUB5V and SUB3.3V lines are monitored by the MCU. When the SUB5V is missing or shorted, the MCU shuts down the unit and blinks the Power LED. Reseat the connectors P7 and A3 and turn on the unit. If the shutdown persists, use a voltmeter to measure the voltage. If it is present, replace the A board. If it is absent, use an ohmmeter to determine if there is a short to ground. When a short is detected, disconnect the connector P7 or A3 to narrow it to the A or P board. A seven-blinks shutdown is always caused by the A board.

# Power LED Blinks 8 or 9 Times

37LZ85 series

8 times Blinking : Main 3.3V

9 times Blinking : Audio SOS

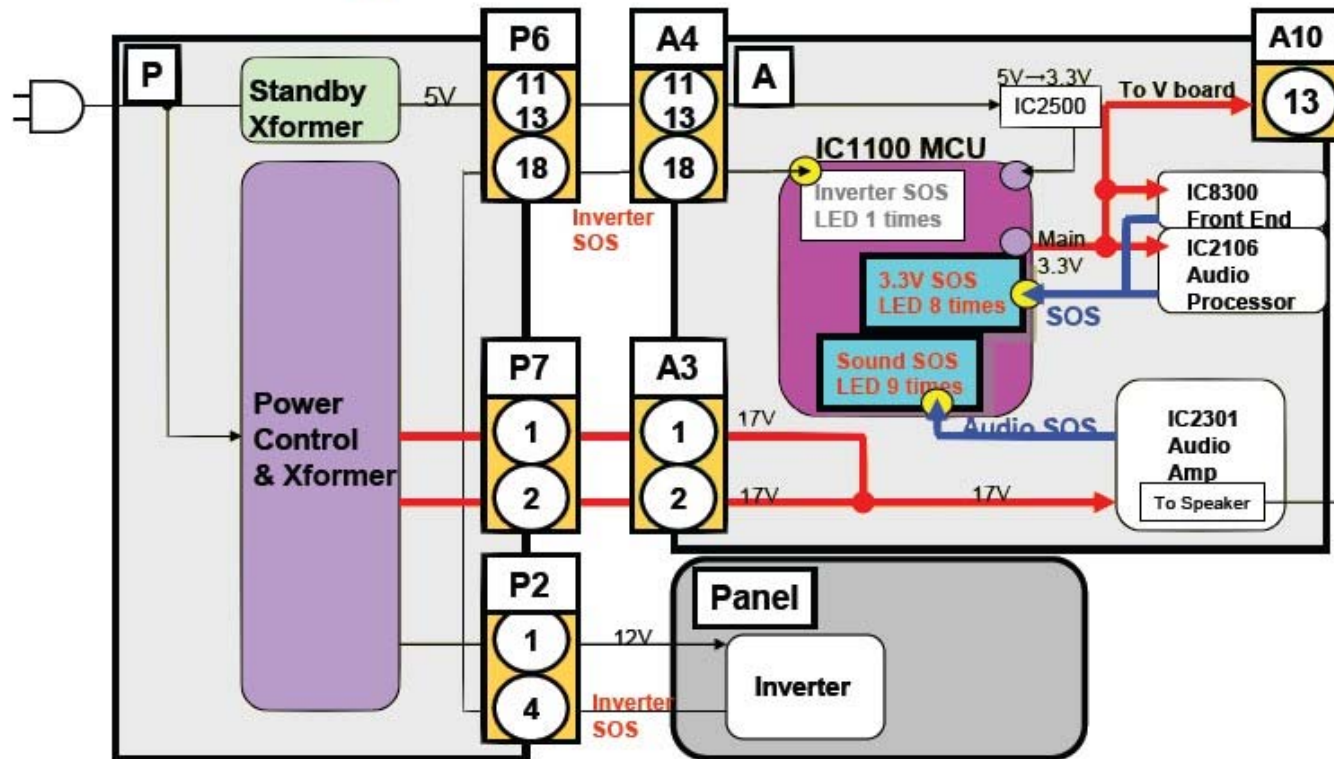

On the A board, the MCU (IC1100) monitors the SOUND+17V line and the operation of the audio power amplifier IC2301. If IC2301, or the 17V lines develops a short to ground, a high is provided to the MCU to trigger a SOS condition. The power LED blinks 9 times.

Use a voltmeter to measure the SOUND+17V source. If it is present, replace the A board. If it is absent, use an ohmmeter to determine if there is a short to ground. When a short is detected, disconnect the connector P7 or A3 to narrow it to the A or P board. A eight-blinks shutdown is always caused by the A board.



# Power LED Blinks 1 Time (TC-32LX85)

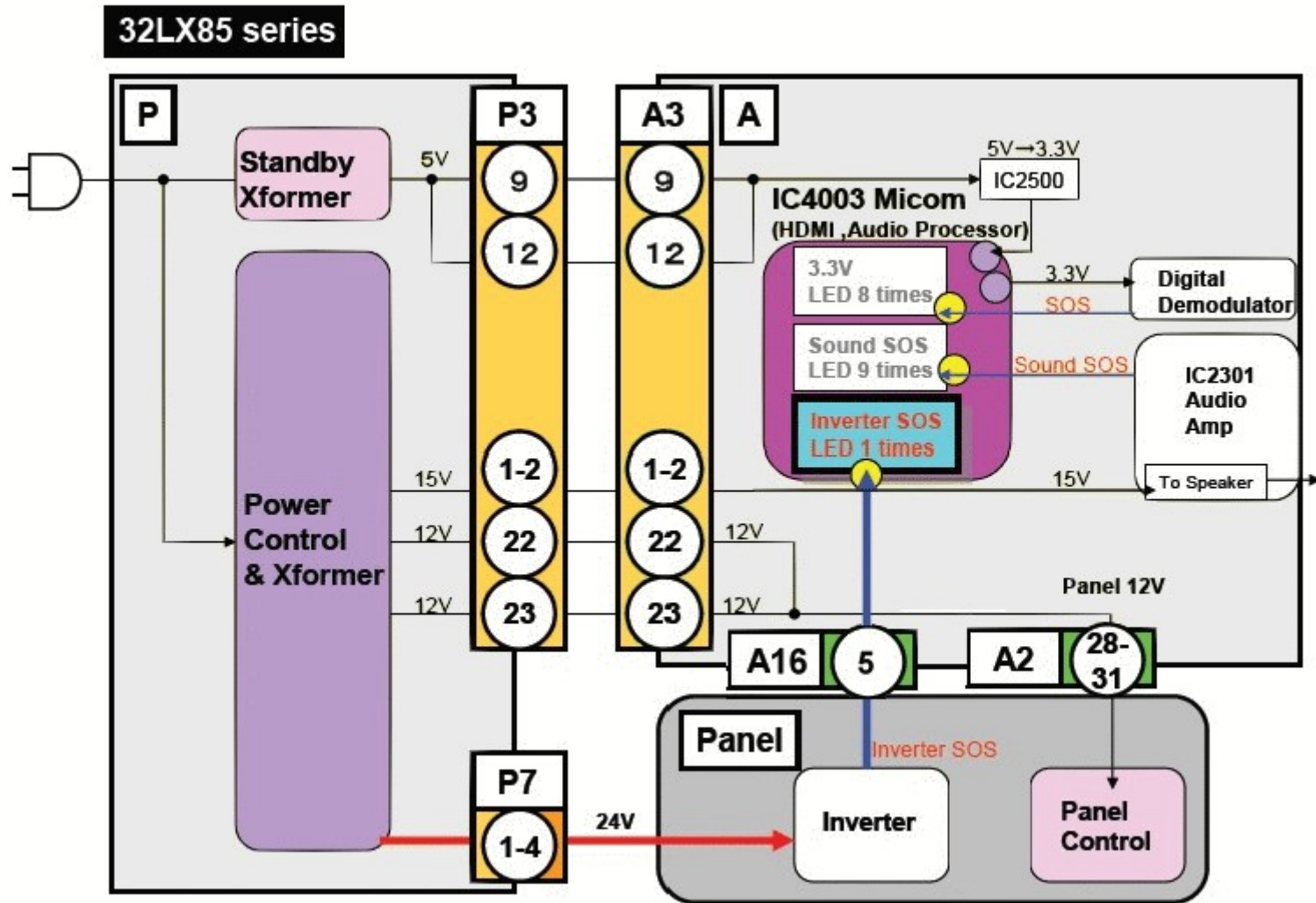

Pin 5 of connector A16 should toggle low after the backlights of the LCD panel turn on. If the backlights do not come on or pin 5 of CN A16 does not toggle low, Reseat the connectors A3, P3, and P7. Confirm the presence of 24Vdc at pin 1 of connector P7 and 12V at pin 28 of connector A2 before replacing the LCD panel.

# Power LED Blinks 3 Times (TC-32LX85)

SUB9V, Sound15V, BT30V Voltage Down, Panel 12V

32LX85 series

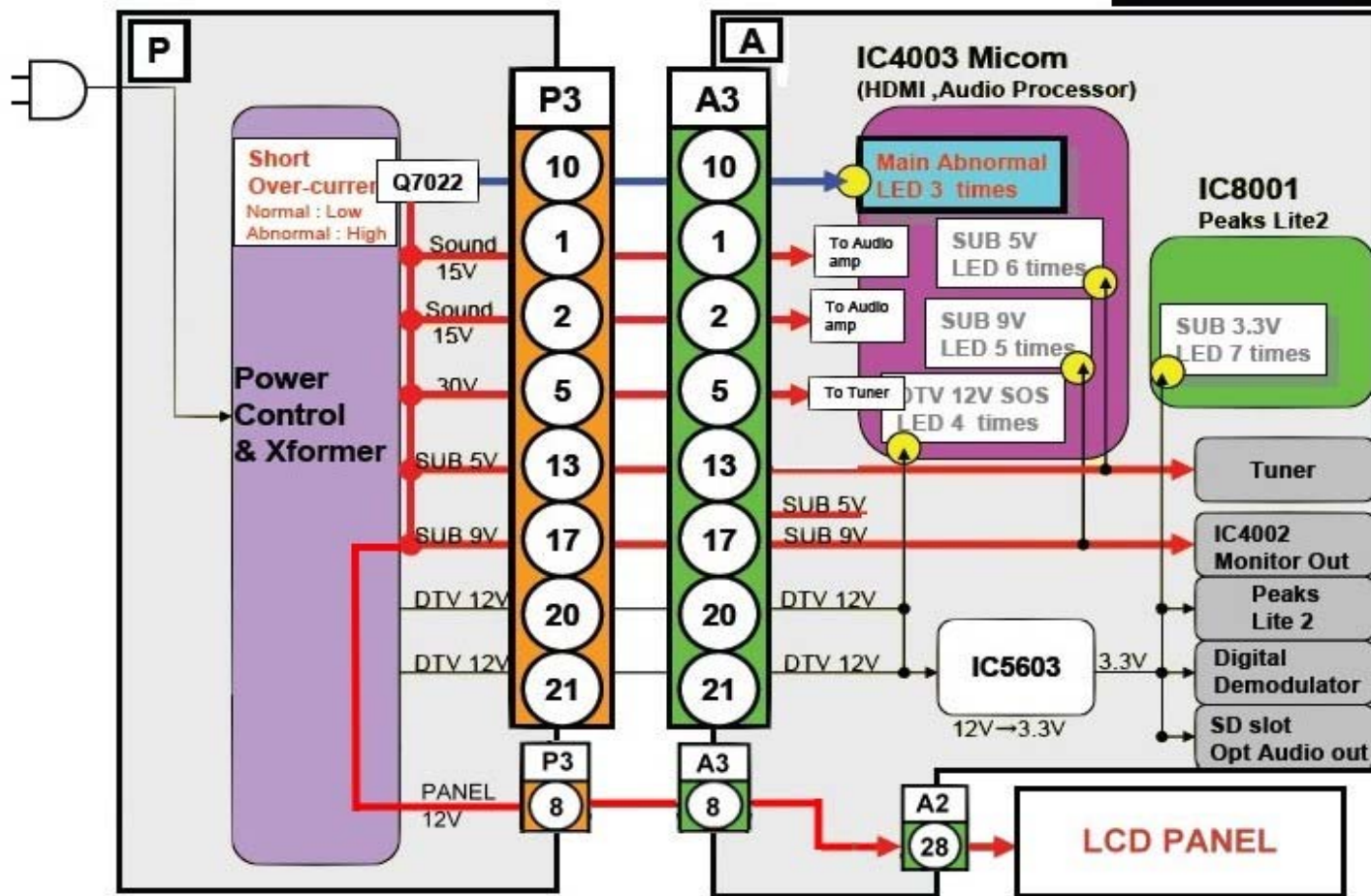

Pin 10 of connector P3/A3 outputs a high when an over-current condition is detected. On the power supply board, locate the test points for the SUB9V, SOUND15V, BT30V, and PANEL12V. Using an ohmmeter, determine if there is a short between each of the test-point and ground. If a test-point is shorted, disconnect the connector P3 or A3 to isolate the short to either the A or P board.

# Power LED Blinks 4 or 5 Times (TC-32LX85)

4 Blinks: DTV12V ----- 5 Blinks: Sub9V

32LX85 series

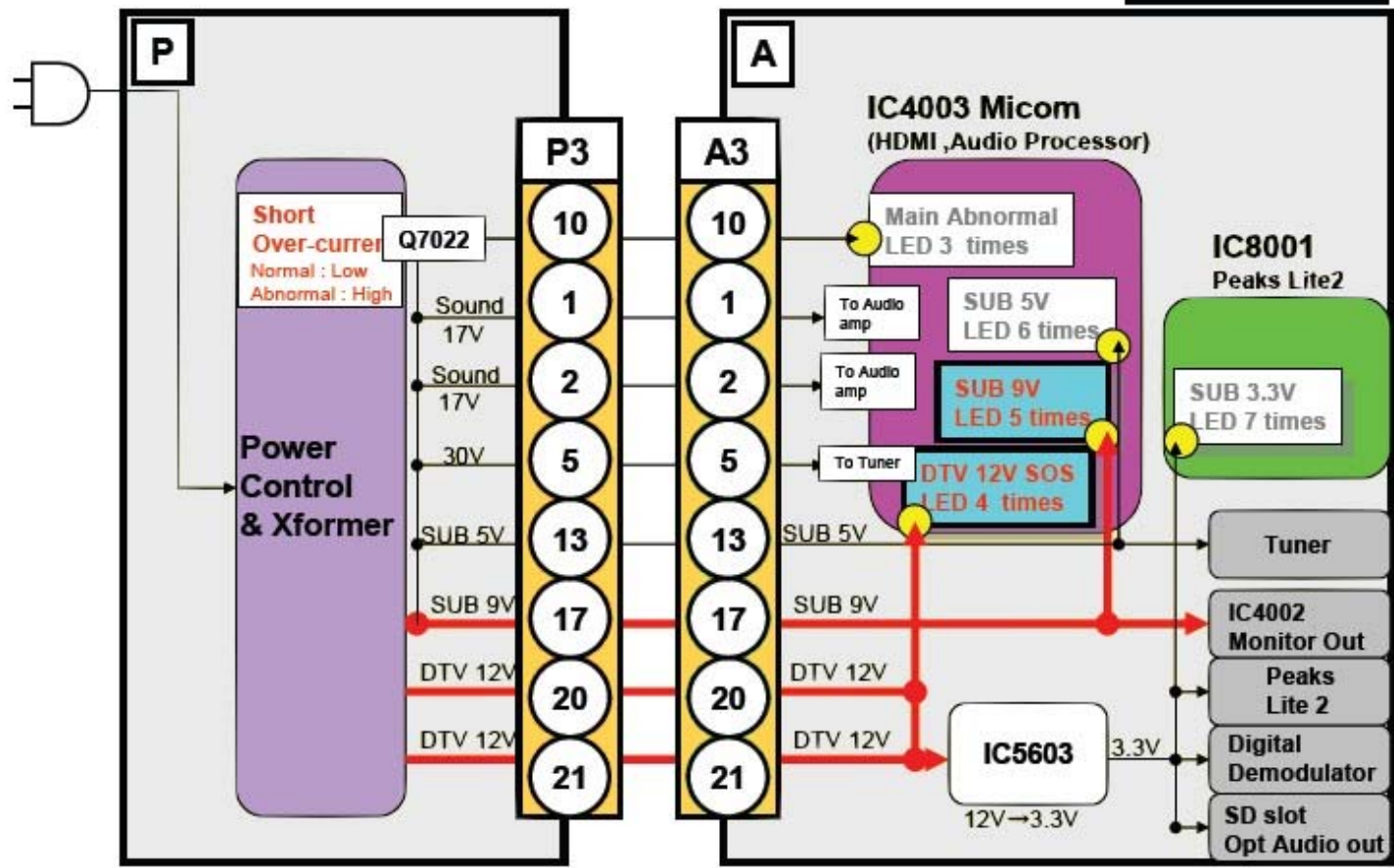

The DTV12V and SUB9V lines are monitored by the MCU. If the voltage corresponding to the number of blinks is missing or shorted, the MCU shuts down the unit and blinks the Power LED. Reseat the connectors P3 and A3 and turn on the unit. If the shutdown persists, use a voltmeter to measure the voltage. If it is present, replace the A board. If it is absent, use an ohmmeter to determine if there is a short to ground. When a short is detected, disconnect the connector P3 or A3 to isolate the short to either the A or P board.



# Power LED Blinks 6 or 7 Times (TC-32LX85)

6 Blinks: Sub5V ..... 7 Blinks: Sub3.3V

32LX85 series

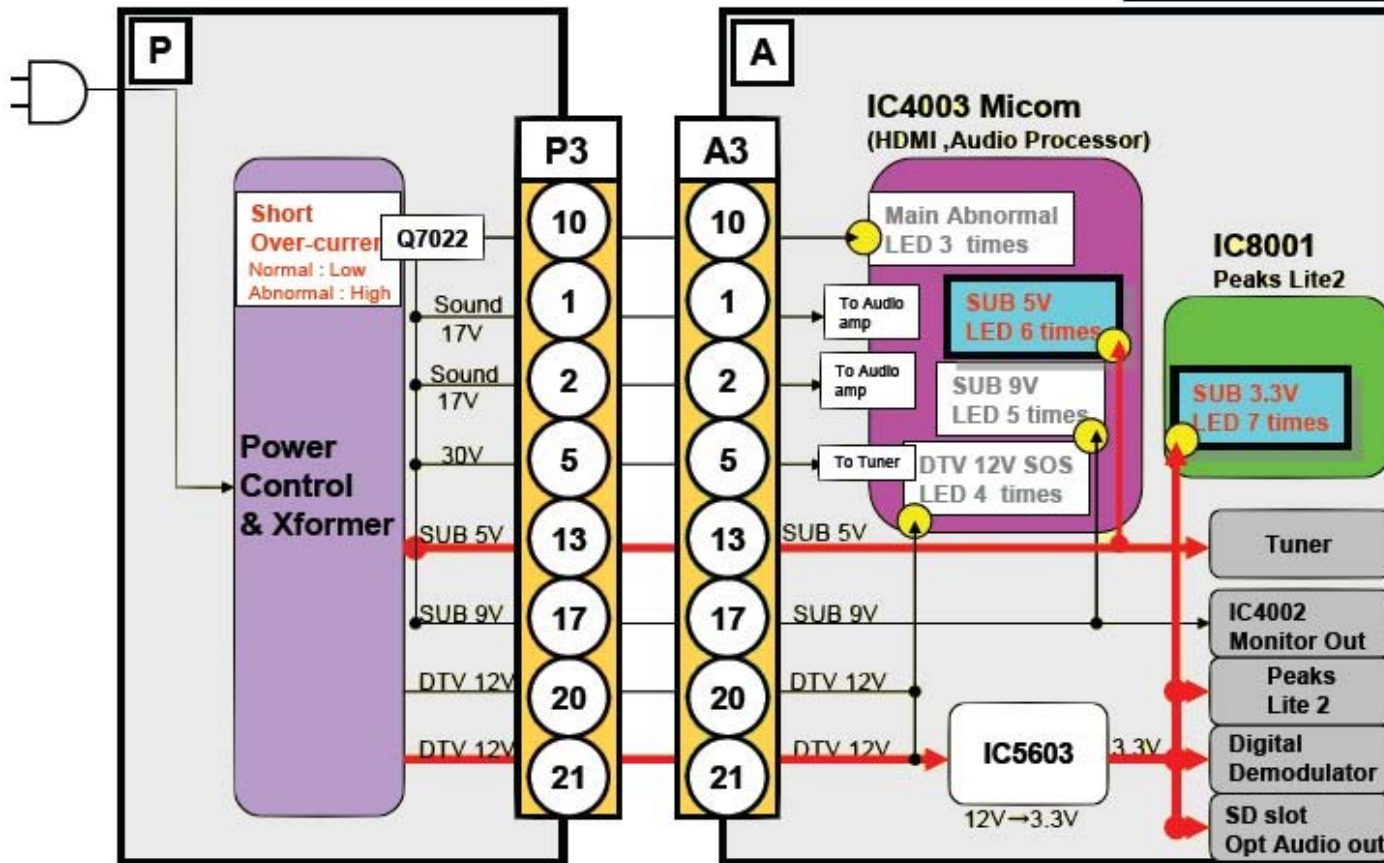

The SUB5V and SUB3.3V lines are monitored by the MCU. When the SUB5V is missing or shorted, the MCU shuts down the unit and blinks the Power LED. Reseat the connectors P7 and A3 and turn on the unit. If the shutdown persists, use a voltmeter to measure the voltage. If it is present, replace the A board. If it is absent, use an ohmmeter to determine if there is a short to ground. When a short is detected, disconnect the connector P7 or A3 to narrow it to the A or P board. A seven-blinks shutdown is always caused by the A board.



# Power LED Blinks 8 or 9 Times (TC-32LX85)

**8 Blinks: 3.3V ..... 9 Blinks: Sound SOS** 32LX85 series

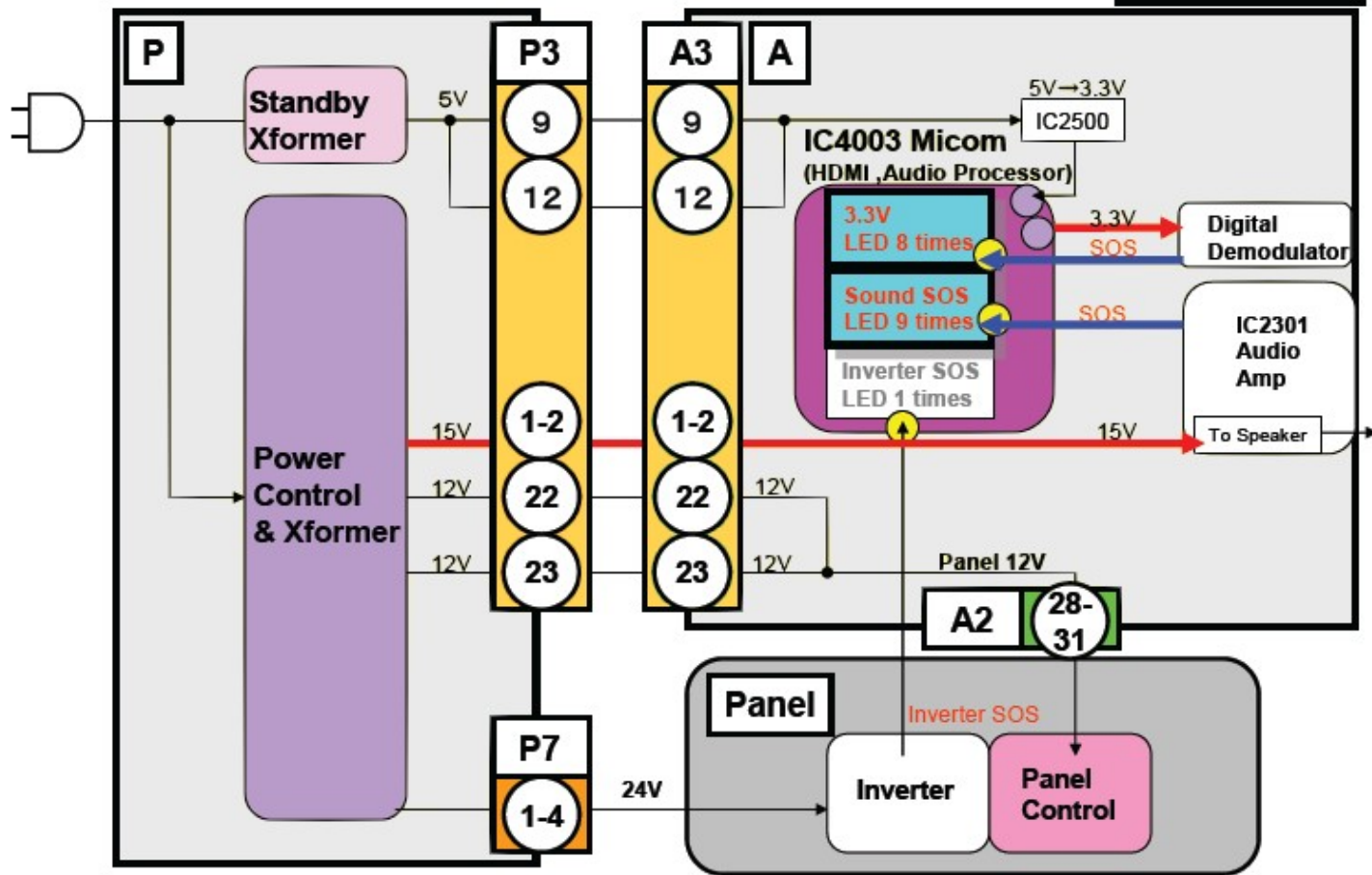

On the A board, the MCU (IC4003) monitors the SOUND+17V line and the operation of the audio power amplifier IC2301. If IC2301, or the 15V lines develops a short to ground, a high is provided to the MCU to trigger a SOS condition. The power LED blinks 9 times.

Use a voltmeter to measure the SOUND+15V source. If it is present, replace the A board. If it is absent, use an ohmmeter to determine if there is a short to ground. When a short is detected, disconnect the connector P3 or A3 to narrow it to the A or P board. A eight-blinks shutdown is always caused by the A board.

# Picture Defect (1)

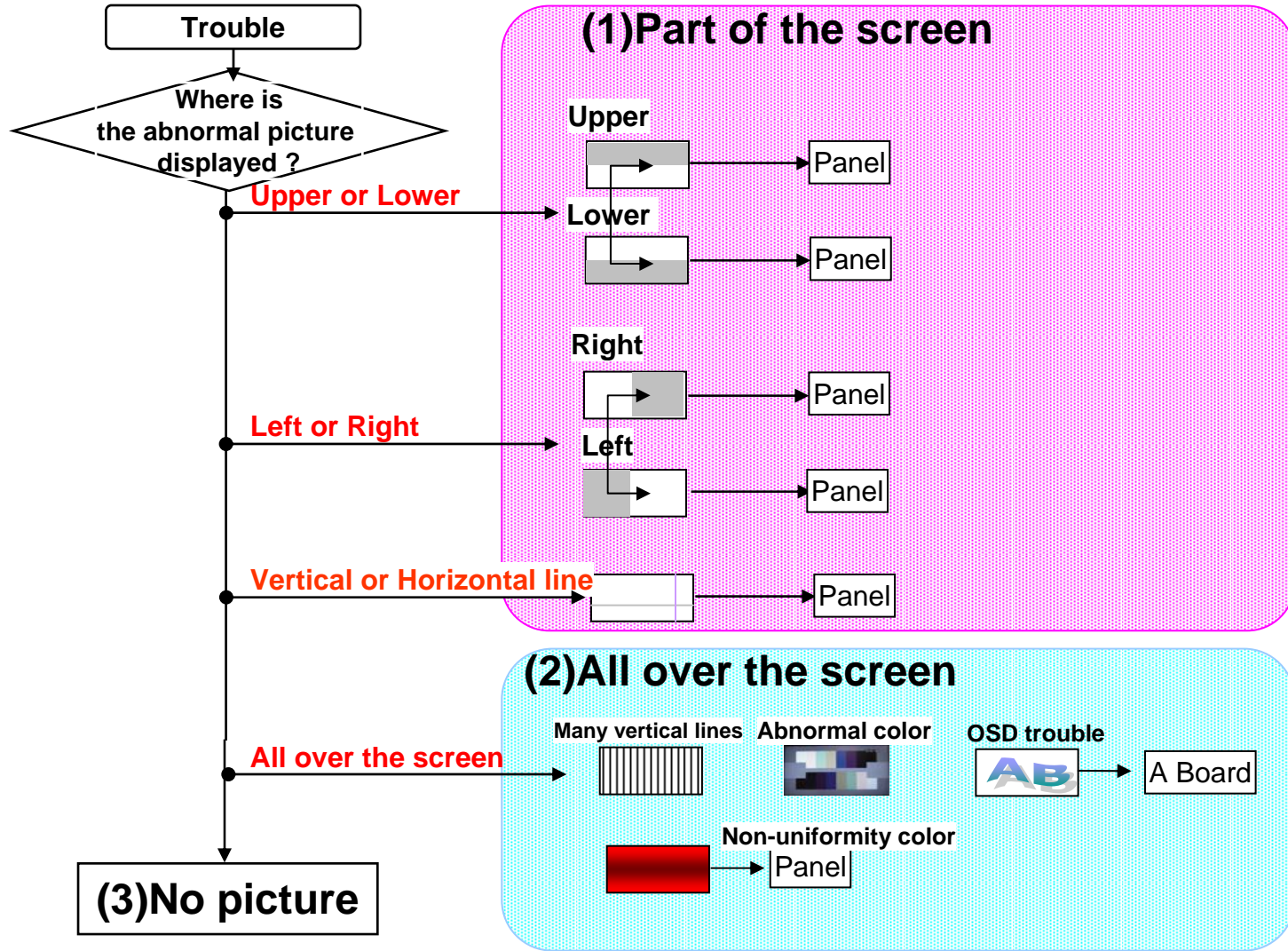

# Picture Defect (2)

## <Symptom>Upper or Lower Defect

Abnormality means

No Picture, Picture noise, abnormal picture,  
Full Horizontal line etc.

### <NG Area>

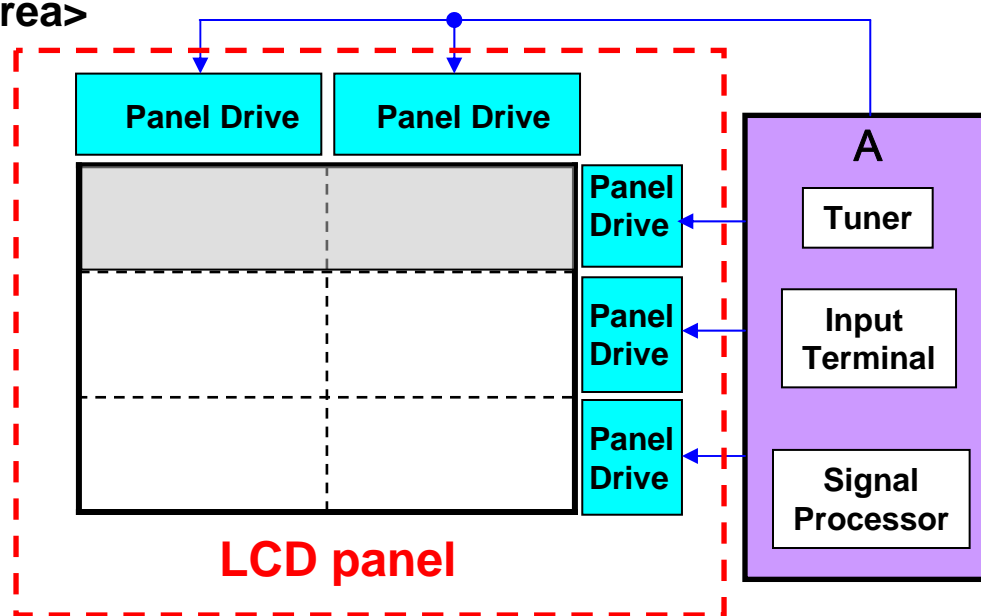

### <Defective parts>

Panel (Panel drive)

Relation to panel drive location,  
1/3 or 2/3 area will be troubled.

### <Actual Symptom>

Symptom: Upper trouble



# Picture Defect (3)

## <Symptom>Left or Right half defect

No Picture, Picture noise, Full Horizontal line, etc.

### <NG Area>

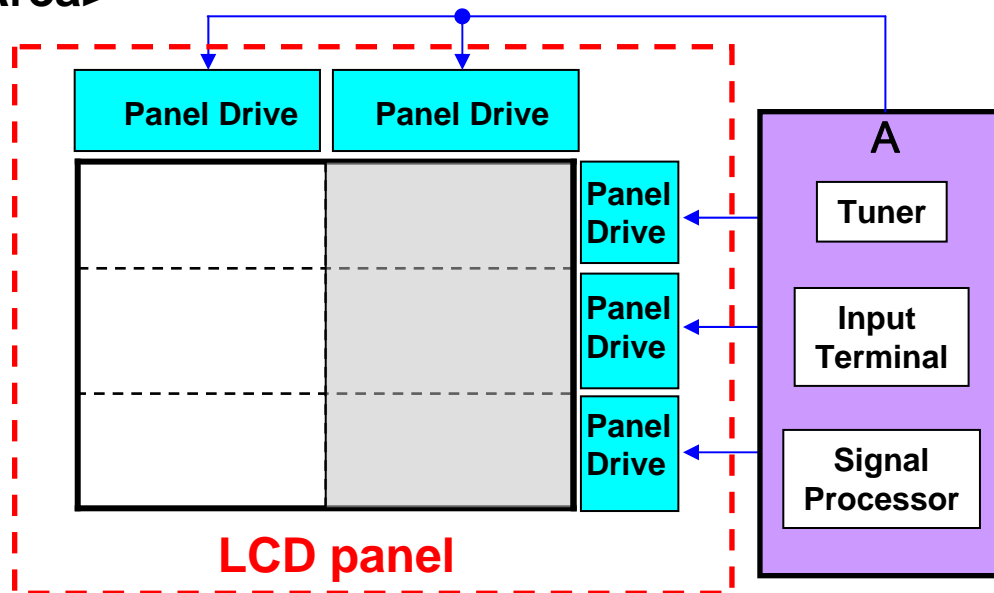

### <Defective parts>

Panel (Panel drive) or A board

### <Actual Symptom>

Symptom: Right half picture trouble

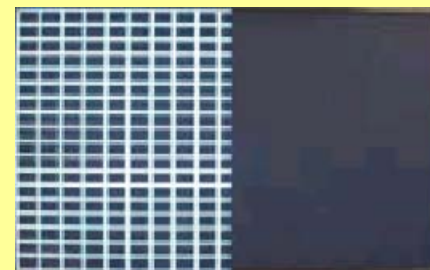

# Picture Defect (4)

<Symptom>Horizontal line

<NG Area>

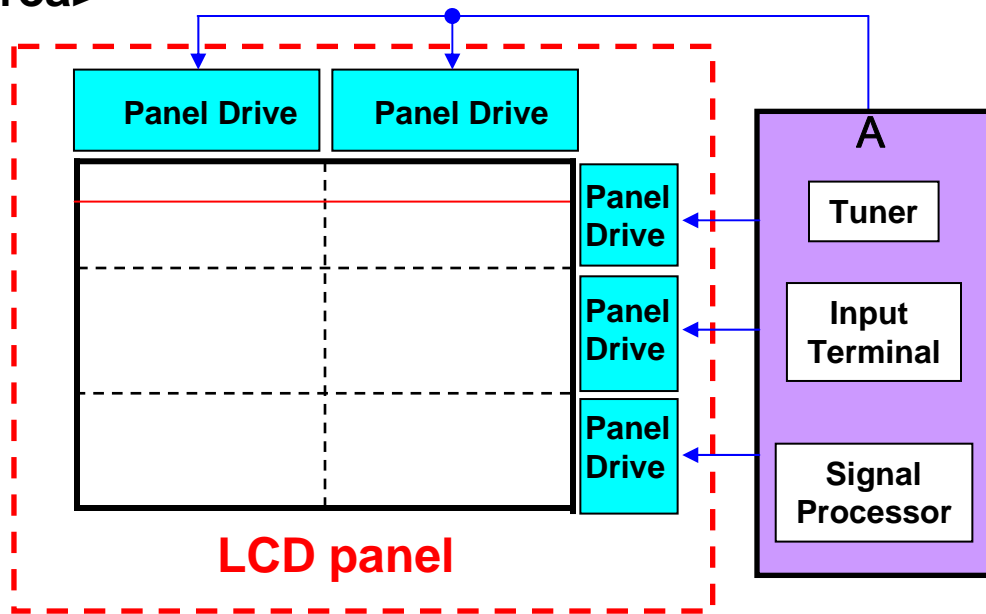

<Defective parts>

Panel

<Actual Symptom>

Symptom: Horizontal line



# Picture Defect (5)

## <Symptom>Vertical line

### <NG Area>

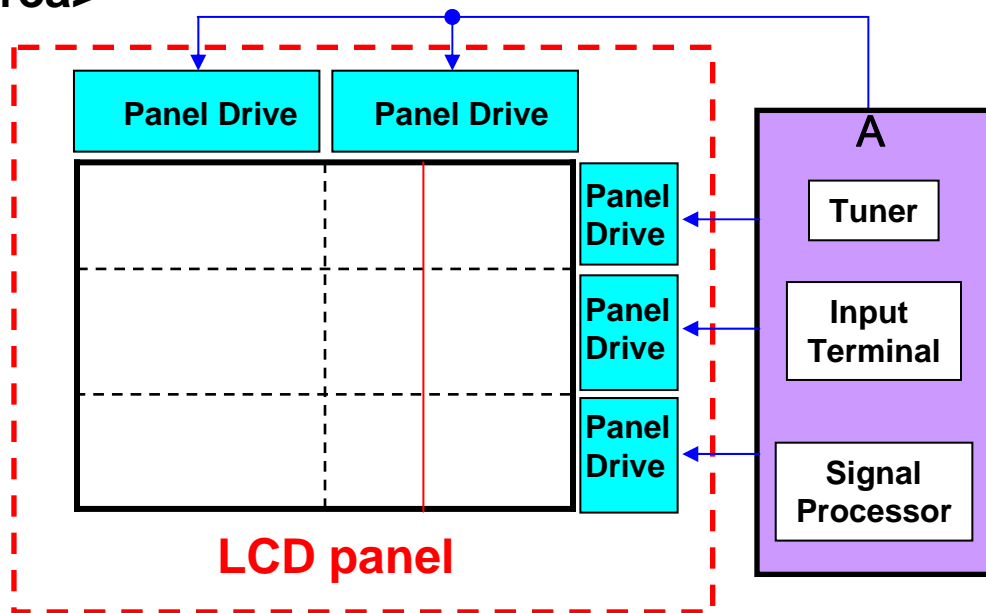

### <Defective parts>

Panel

## <Actual Symptom>

Symptom: Thin vertical line

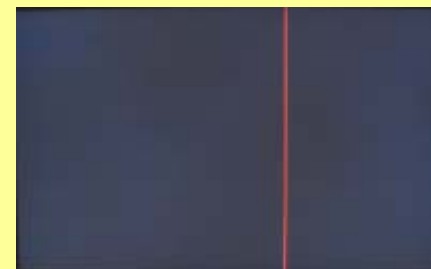

# Picture Defect (6)

<Symptom> Vertical line noise

<NG Area>

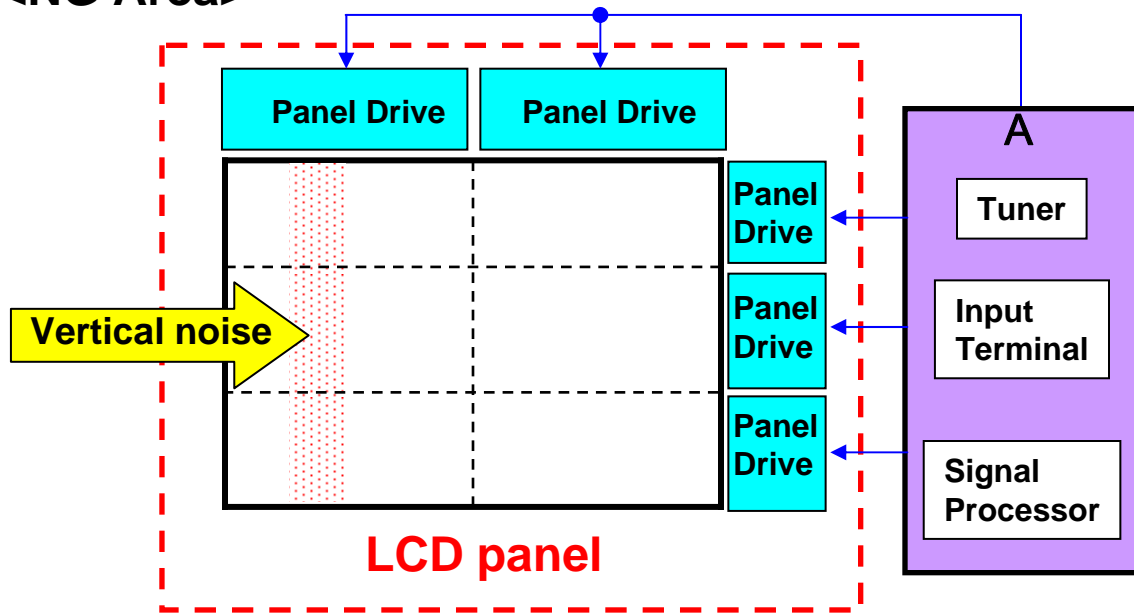

<Defective parts>

Panel or A board

<Actual Symptom>

Symptom: Vertical noise



# Picture Defect (7)

<Symptom>Sub picture NG

<NG Area>

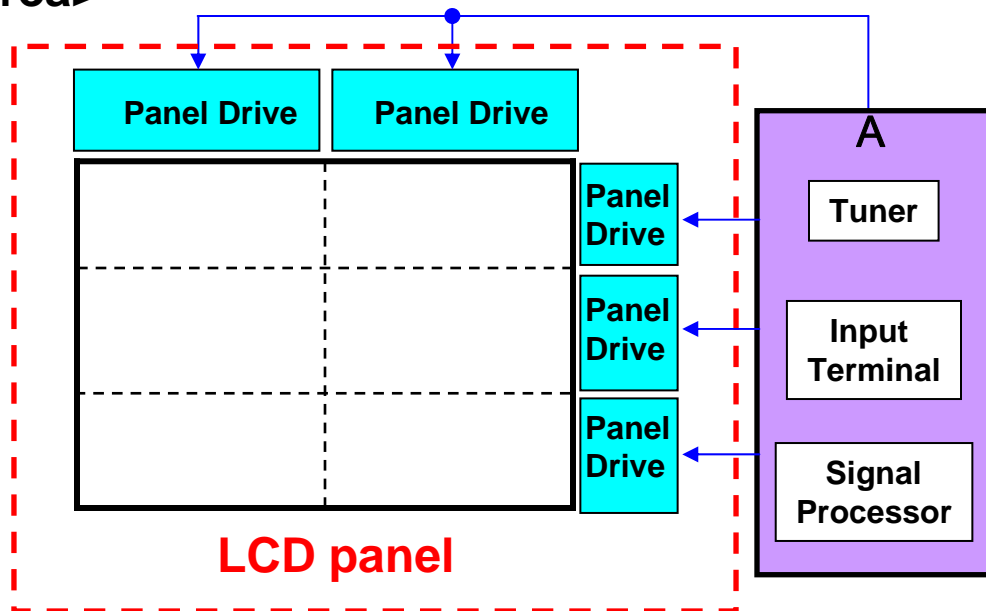

<Defective parts>

A board

<Actual Symptom>

Symptom: Sub picture NG



Note:

There is not sub picture function on some models.



# Picture Defect (8)

<Symptom>Non uniformity color

<NG Area>

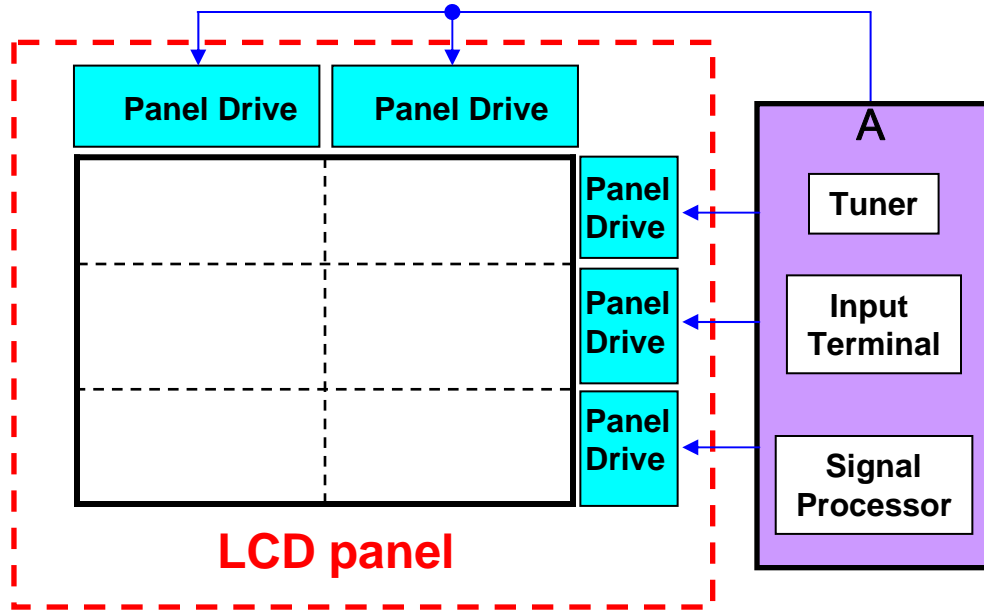

<Defective parts>

Panel

<Actual Symptom>

Symptom: Irregular color



# Picture Defect (9)

<Symptom> Vertical lines all over screen

<NG Area>

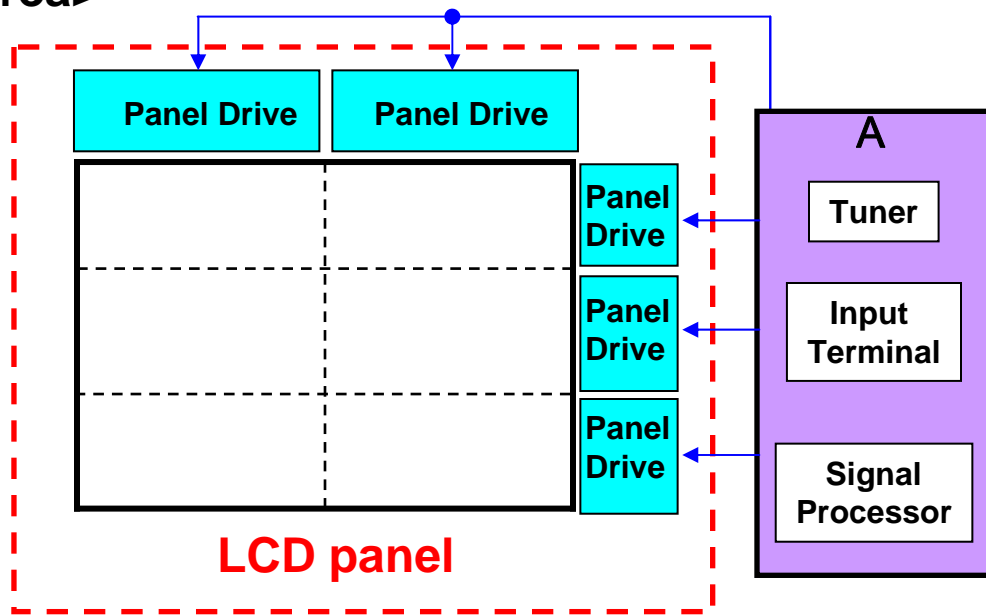

<Defective parts>

Mainly A board, in some cases panel

<Actual Symptom>

Symptom: Vertical line all over screen



# Picture Defect (10)

<Symptom>O.S.D. trouble

<NG Area>

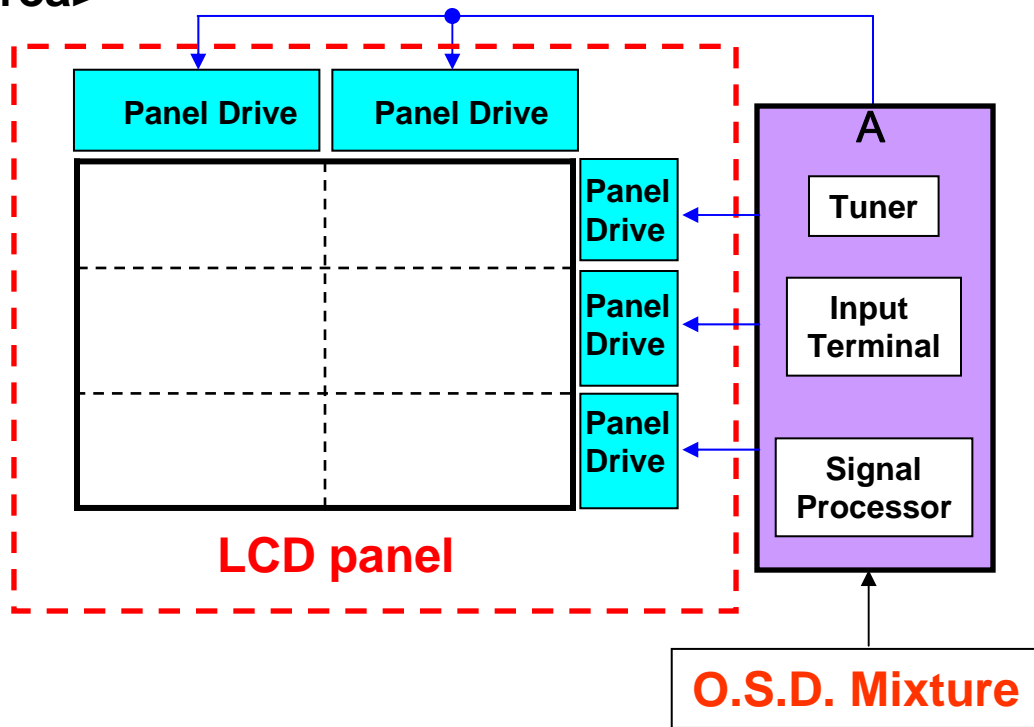

<Defective parts>

A board

<Actual Symptom>

Symptom: OSD trouble  
(Color is normal)



# Picture Defect (11)

<Symptom> Abnormal color

<NG Area>

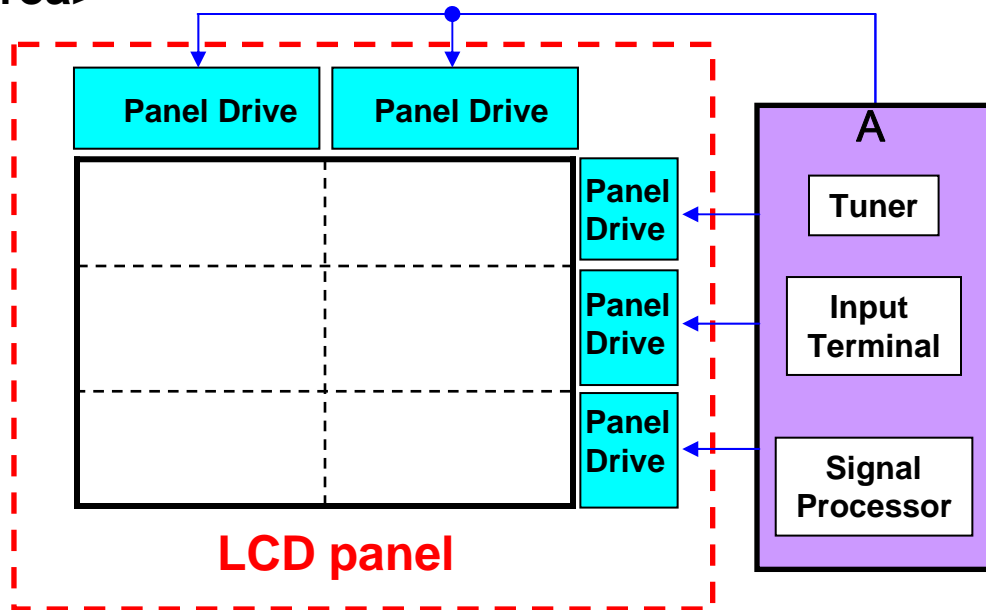

<Defective parts>

A board

<Actual Symptom>

Symptom: Abnormal color

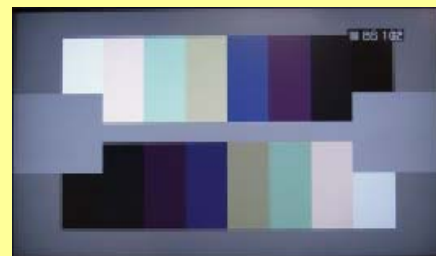

# Picture Defect (12)

<Symptom> **No Picture with Normal Sound**

<Actual Symptom>  
**No Picture and Normal Sound**  
 Reason: A board, Panel,

<NG Area> All

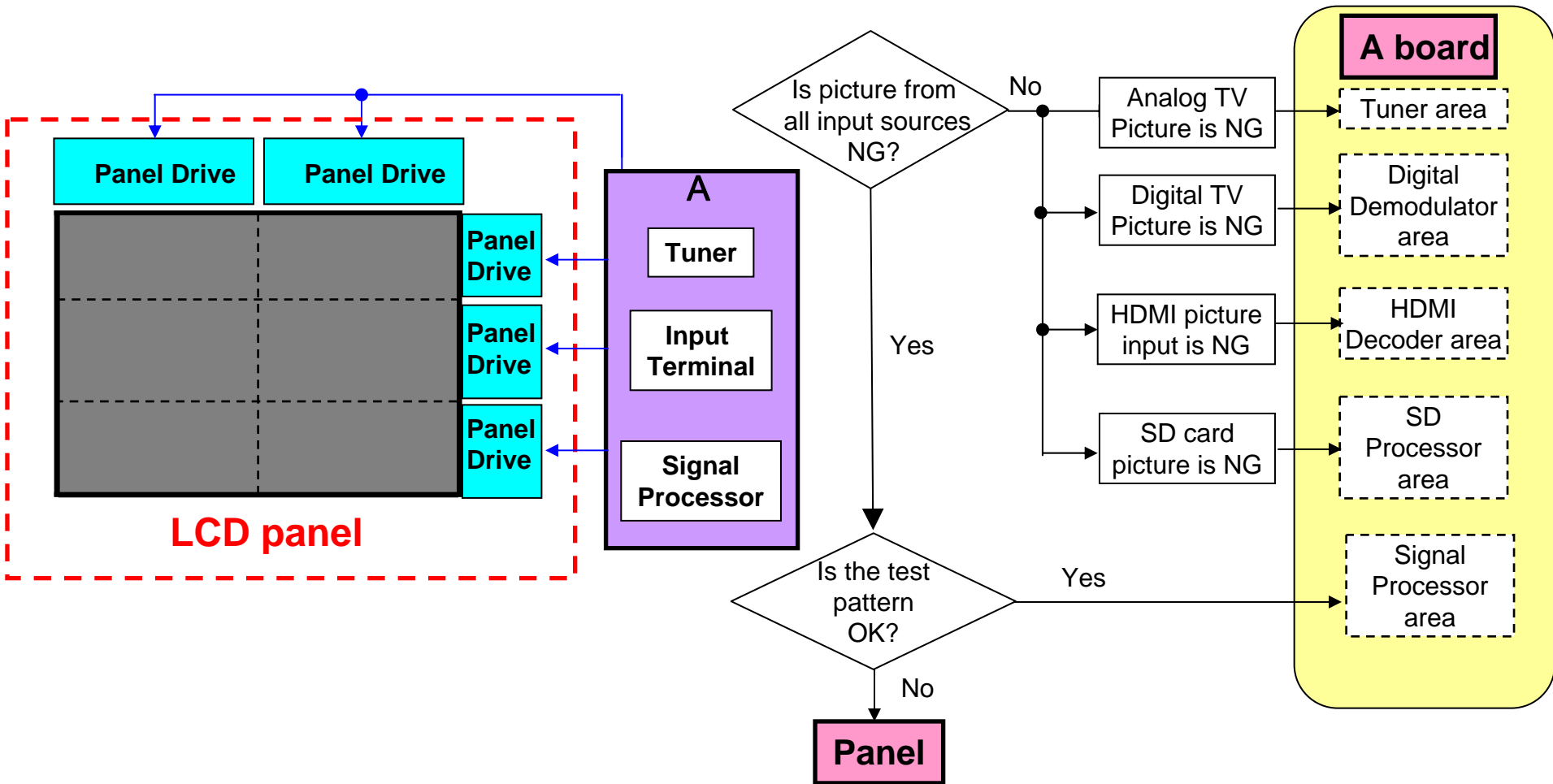

## <Symptom> Sound Trouble

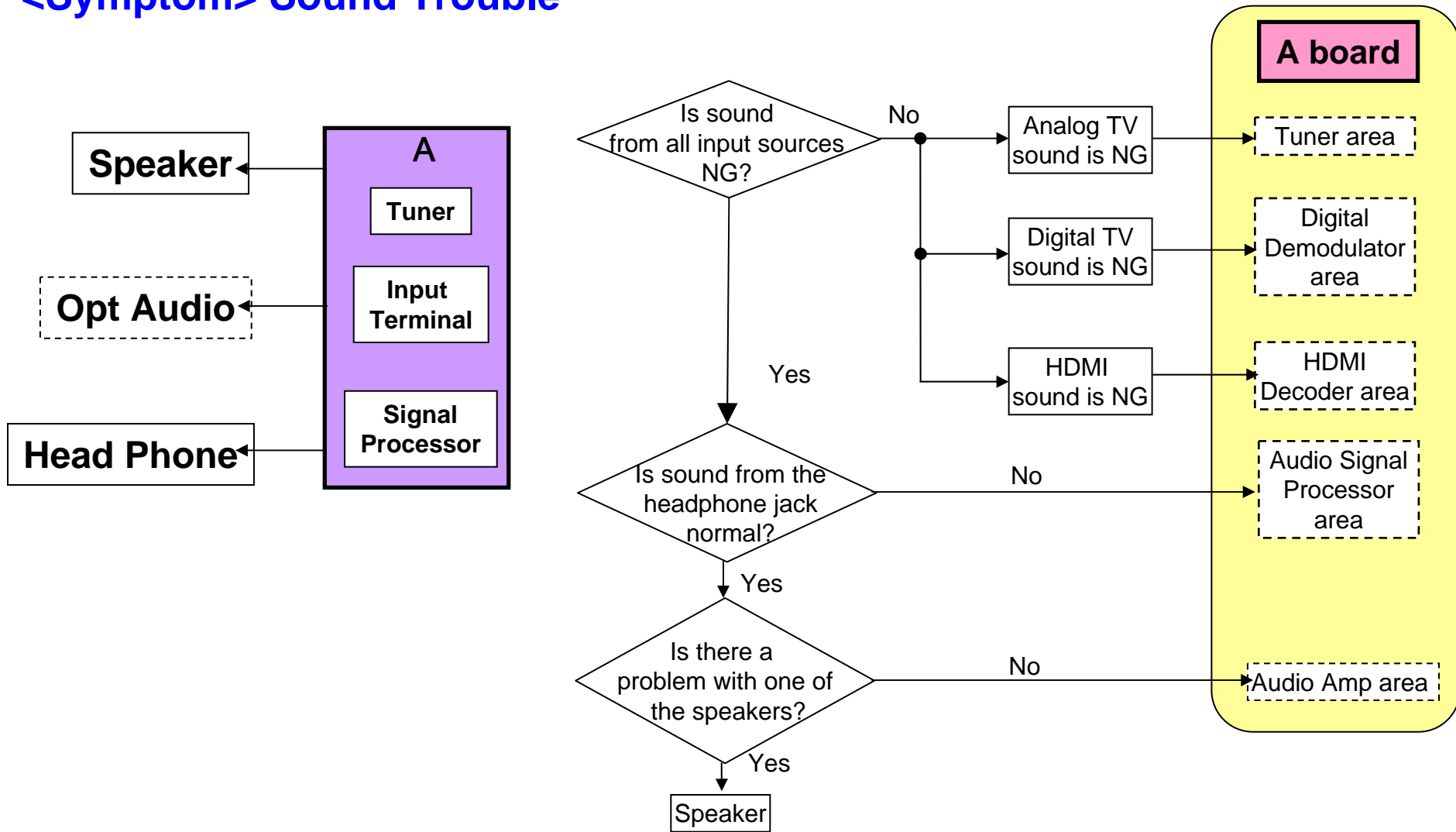

## 2008 LCD Display Televisions



- 1. Panel Free Run System**
- 2. Data copy to SD card**
- 3. Local Maintenance**
- 4. Picture Refresh Mode**

## Service information (1) Panel Free Run System (1)

When a picture problem is encountered, the test pattern may be used to determine whether the symptom is the result of a defective **A board or the panel.**

The “**Test pattern**” is displayed as follows:

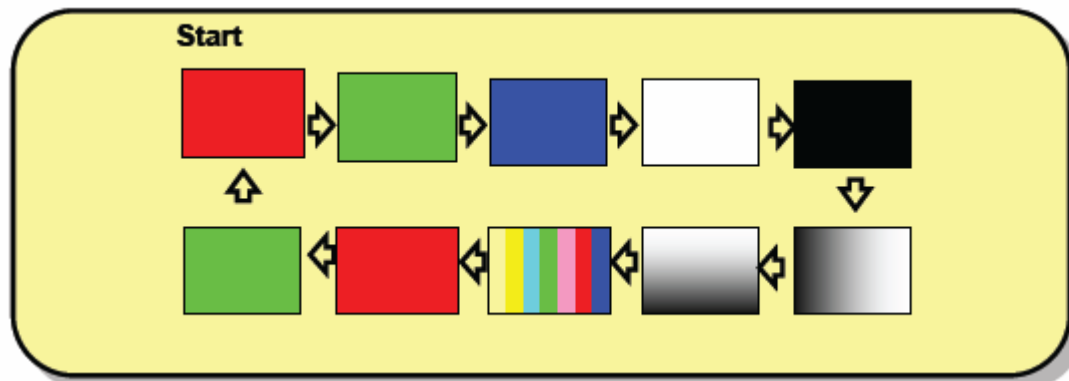



## Service Information (1) Panel Free Run System (2)

Test pattern displayed on the previous page are included in the **“Panel Free Run”** mode.

### How to enter **“Panel Free Run”** mode

Same time { Press **“VOL-”** button on TV unit  
Press **“SUB MENU”** button 3 times on remote controller

Main power off to exit.

### **“Panel Free Run”** operation

Test Patterns are generated at Panel side

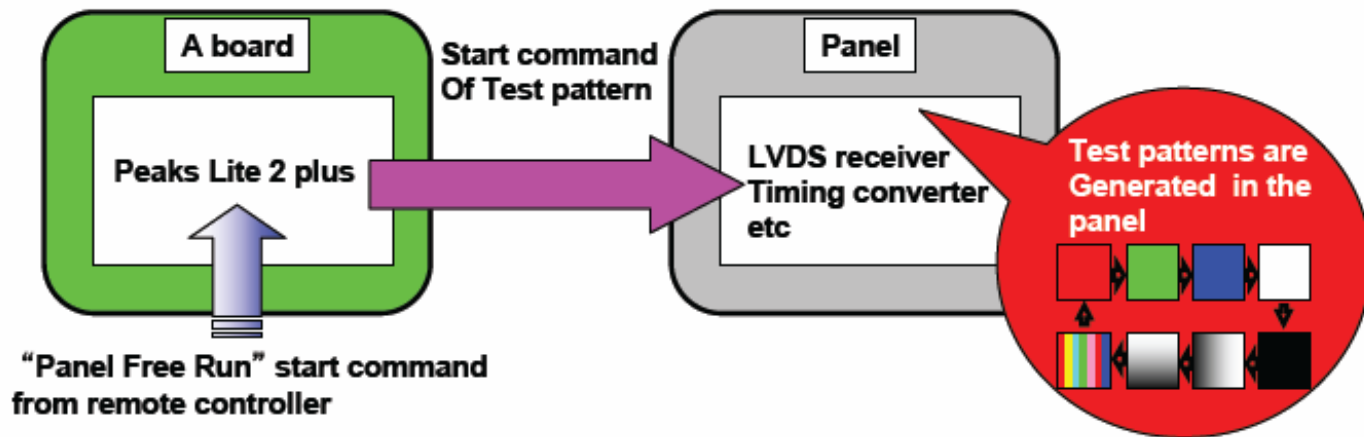

## Service Information (1) Panel Free Run System (3)

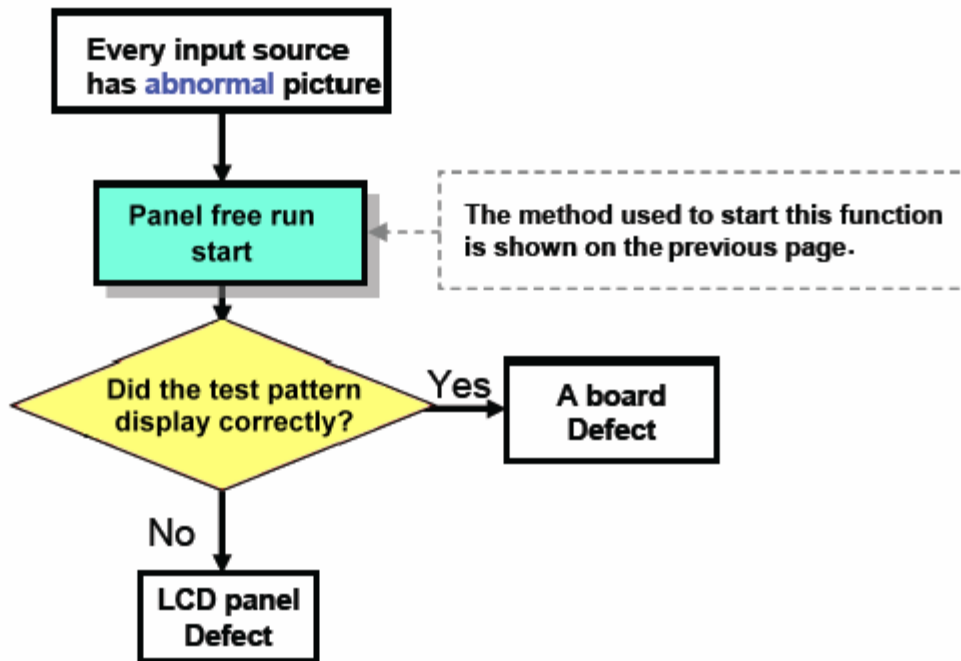

The test pattern is generated by the panel.

# Copy data to SD card (1)

LCD (and PDP) 2008 model has the new SD card copy data function for **2** situations

**1** Copy customer's data to SD card when replacing the A board.

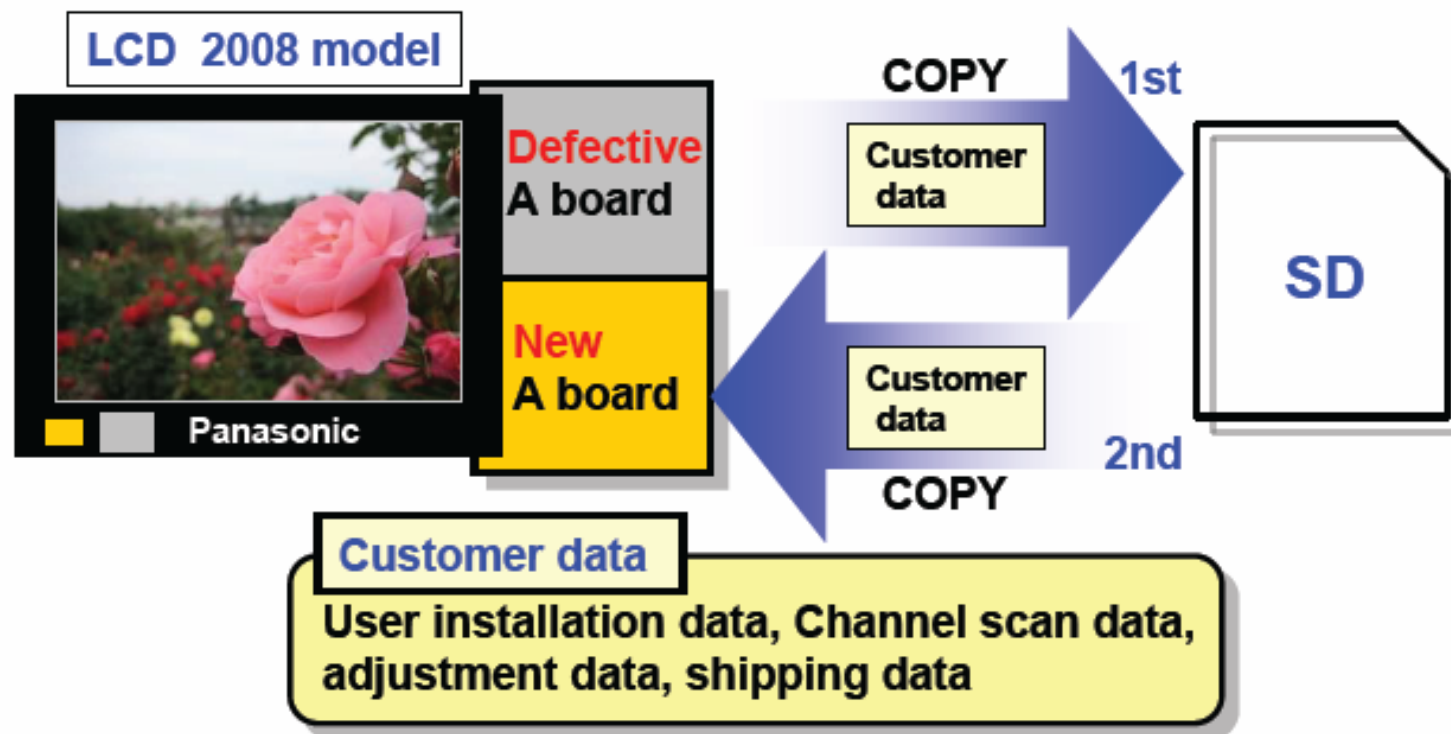

**We don't have to readjust customer's data after A board replacement.**

# Copy data to SD card (2)

## 2 Copy prompt data to SD card for new installation

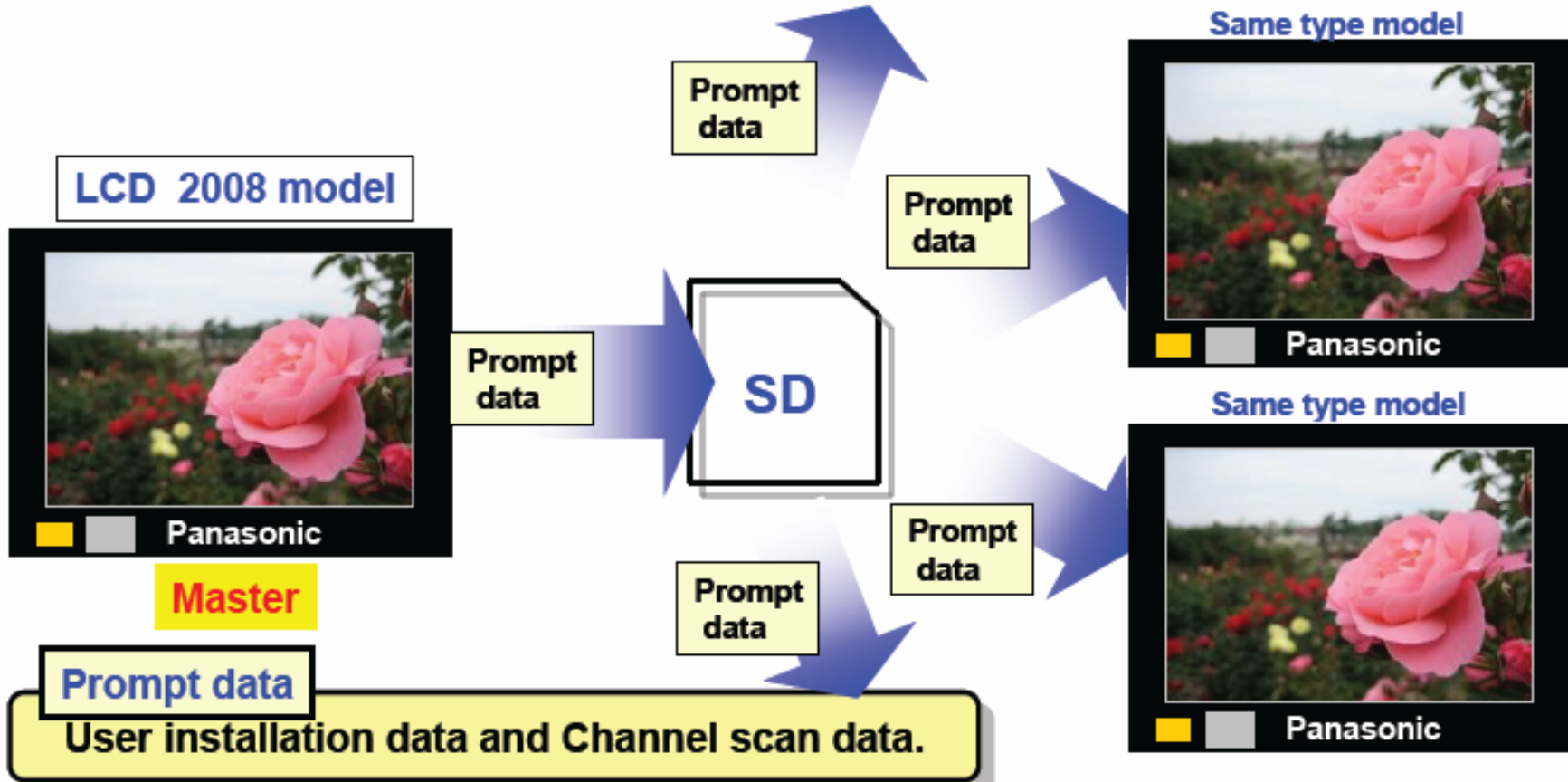

Copy Master TV setting data to a SD card and distribute to another TV. It's useful when we install many TV at same time, like in a hotel.

### <Primary>

Make the **operation file** inside of a SD card.  
Make file for each purpose.

File for replacement of board : boadreplace. pwd  
File hotel installation: hotel.pwd

When you change the file name , start the new text file and change the file name.  
Please make just **only 1 file**, for preventing operation error.



# Copy data to SD card (4)

## Copy data from TV set (Defective A board) to SD card.

### How to operate(1/2)

1. Power on the TV.
2. Insert the SD card in the SD card slot.
3. The Copy Program function will start automatically.

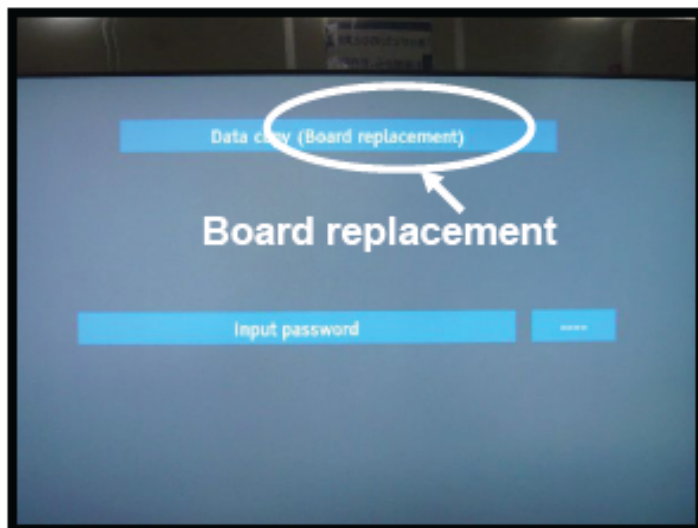

① Board replacement program

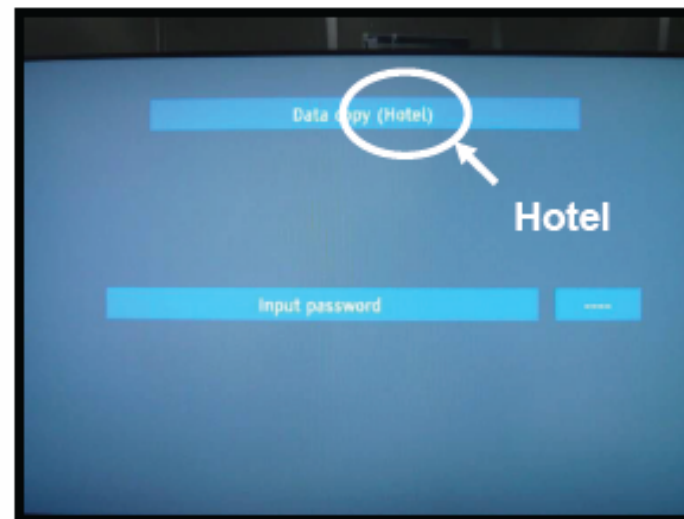

② Hotel program

# Copy data to SD card (5)

Copy data from TV set (Defective A board) to SD card.

## How to operate(1/2)

1. Power on the TV.
2. Insert the SD card in the SD card slot.
3. The Copy Program function will start automatically.

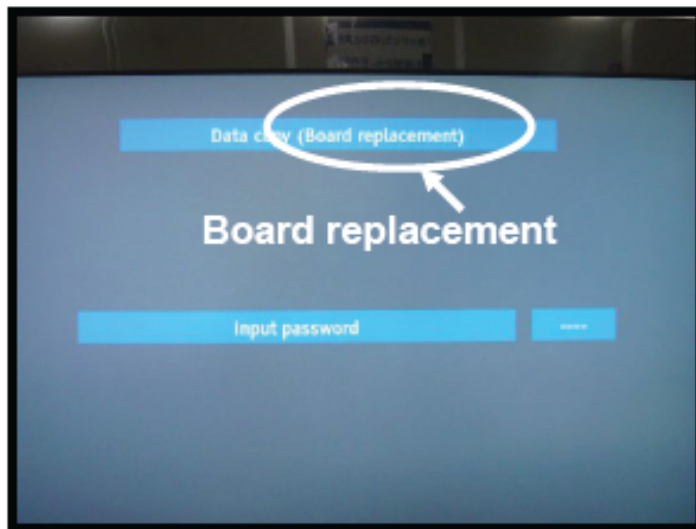

① Board replacement program

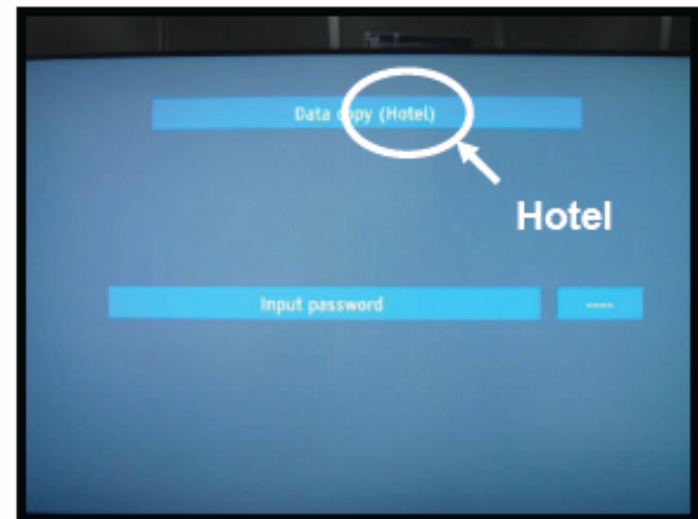

② Hotel program



## Copy data to SD card (6)

When data copy from the TV set to the SD card is finished, we can see the completion message as follows. In this situation the removal of the SD card is possible.

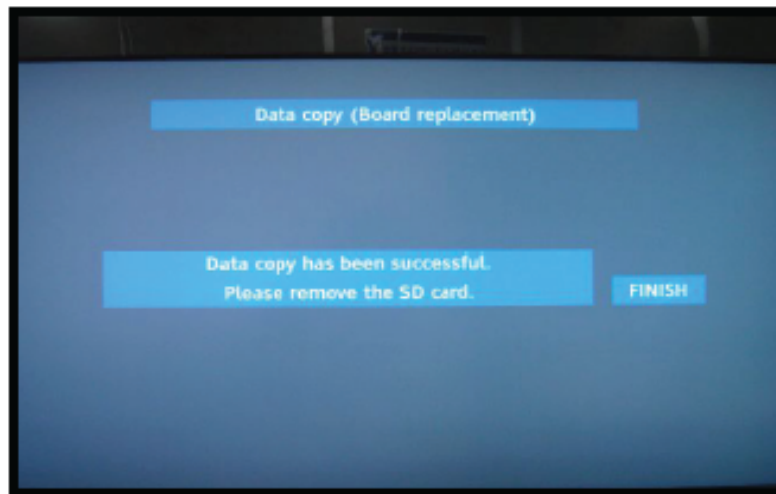

Data copy from the TV set to the SD card is finished.  
Eg: board replacement mode

We can check the copied data of the SD card by using a PC. Please check the folder as follows.

1. For board replacement : user setup
2. For Hotel installation : Hotel



## Copy data from the SD card to the TV

Insert the SD card with copied data into the SD card slot of the TV.  
The “Data Copy” program will start automatically.

Please input the password by using the keys of remote control.

2771 : After replacing the board.

4851 : For hotel installation.

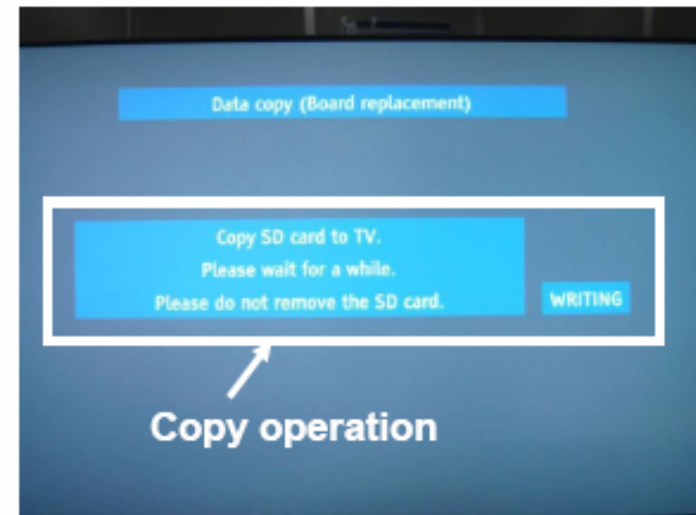
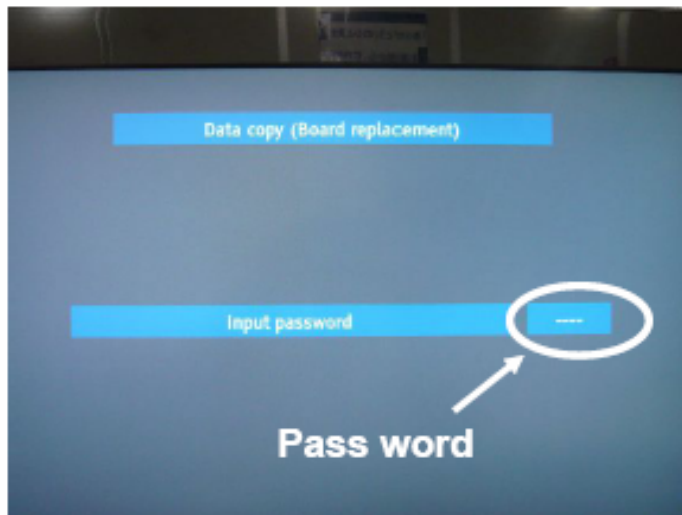

## Copy Data from the SD Card to the TV (2)

When copying data from the SD card to the TV unit is finished, this screen will appear as shown below.

Please take out the SD card and unplug the unit.

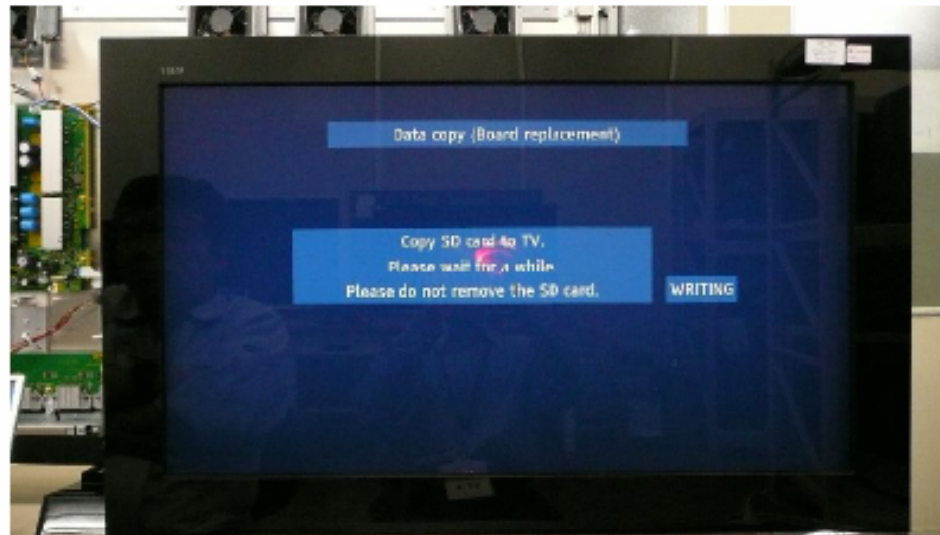

This copy operation is possible, between the same type of 2008 model only.

# Copy Self Check Data to the SD Card (1)

**New**

**Copy Self check data to SD card.**

It's effective even under **black out screen**.



Note : For 2008 Model Only : LCD with Peaks lite2 and all PDP

## How to copy Self check data to SD card

- 1) Power on the TV set
- 2) Insert the SD card into the SD card slot.
- 3) Start "Self check " as usual.  
If necessary, please refer to the service manual.
- 4) After copying the selfcheck data, the file "selfchecklog" is written on the SD card automatically. We can see this data by using a PC.

# Copy Self Check Data to the SD Card (2)

Usual  
Self check  
screen



Message  
SD card is inserted



## Log data indication of SD card

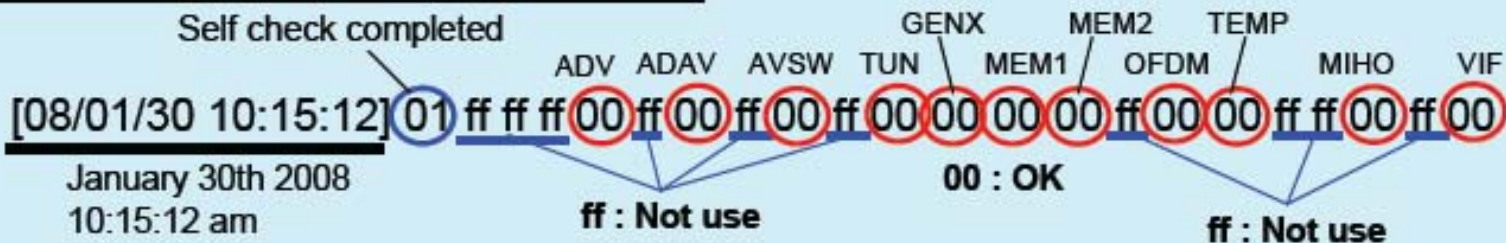

# Copy Self Check Data to the SD Card (3)

## Self check log data result at SD card

Sample

Item No. 1 2 3 4 5 6 7 8 9 ..... 19 20  
 [2008/05/17 10:24:33] 01 00 00 00 00 00 00 00 FF 00 00 00 00 00 00 00 00 00 00 00 00

yy: year,  
 mm: month,  
 dd: day,  
 hh: hour,  
 mm: minute,  
 ss: second

Item 1:exec flag  
 Selfcheck was completed

Item 4: Tuner 2 is OK

Item 8: ADAV4601 is NG

00 means OK  
 FF means NG or out of Self check

No.	Self check item		
1	<b>exec flag (01 stands for completed)</b>	6	avsw (Audio & Video SW)
2	PEAKS	7	adv (ADV7495A)
3	TUN1	8	<b>adav(ADAV4601)</b>
4	<b>TUN2</b>	9	genx (Genx or Hudson)
5	FE (Digital demodulator)	10	Mem1 or mem2

# Local Maintenance (1)

## What is “Local maintenance”?

Diagnosis system for tuning error and initial scanning log data of Digital TV. (ATSC type)

## How to enter “Local maintenance” (1/2)

- 1) Press the “VOL-” button on the unit and press the “INFO” button three times on the remote control at the same time.
- 2) After entering the service mode, please select SRV-TOOL by pressing the 1 or 2 button of the remote control. (Left side photo)
- 3) Please push the “OK “ button to select item SRV-TOOL.

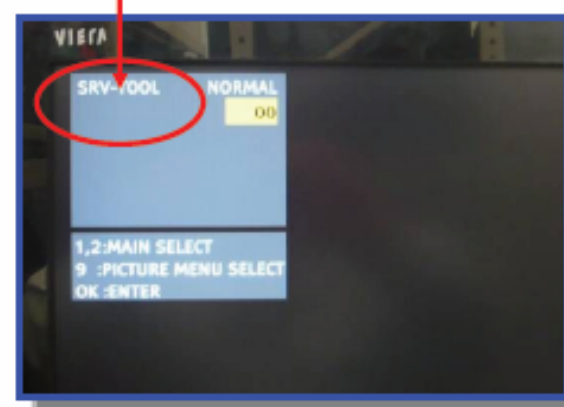
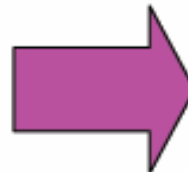
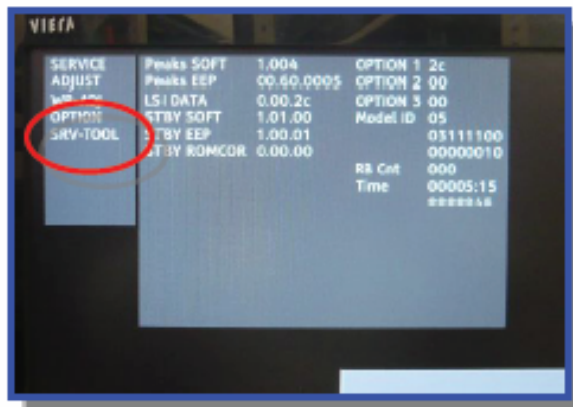

Go to Next Page

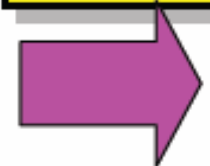



## How to enter "Local maintenance" (2/2)

- 1) As a next step, you can enter SRV-TOOL menu like as left photo.
- 2) Please select "Local Maintenance" by using the remote control button.
- 3) After entering "Local Maintenance" you can see the Log menu of Local maintenance as in the photo on the right.
- 4) Meaning of Local Maintenance Logo message is shown on next page.

From  
Previous Page

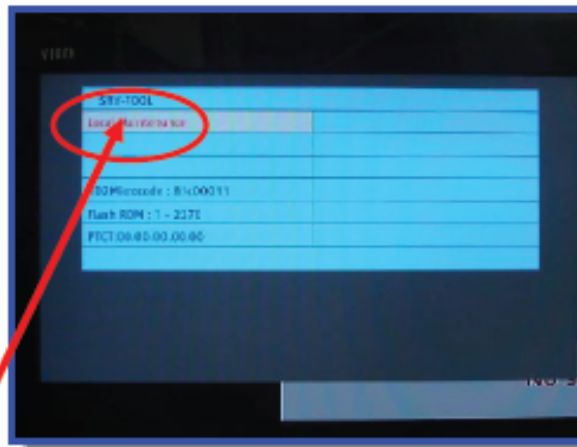
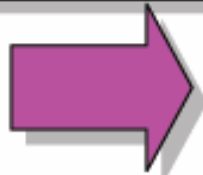

Menu of the "SRV-TOOL"

Local maintenance

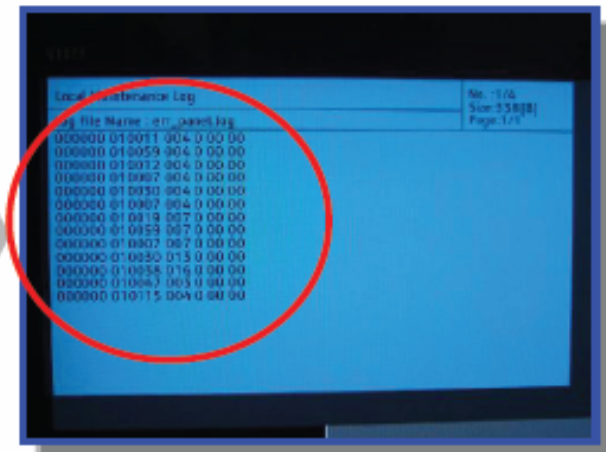

Log menu of Local Maintenance

## Log file name selection

Log file

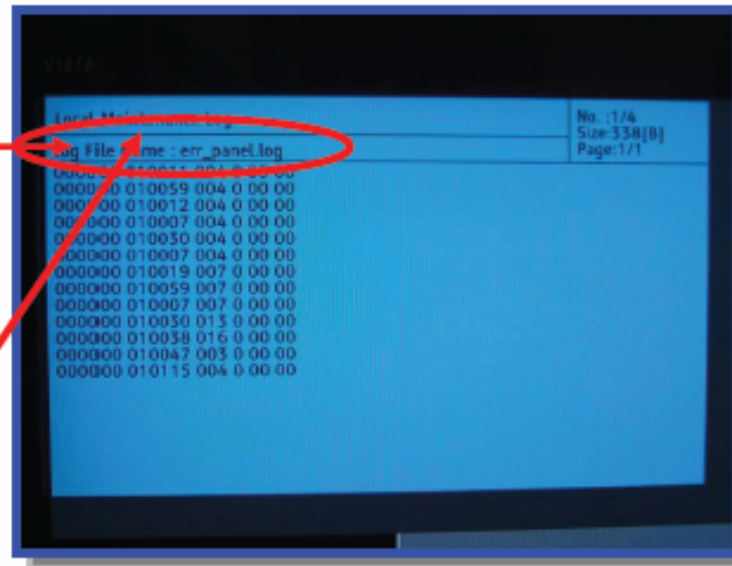

Log menu of Local Maintenance

1. **errpanel\_log.0** ... When error message took place, kind of message, date and time, tuning log.
2. **pow\_msg.log** ... Only analysis of engineering
3. **s\_sig\_kill.log** ... Only analysis of engineering
4. **sig\_msg.log** ... Only analysis of engineering
5. **svl.log** ... Auto scan date and tuning log.
6. **cec.log** ... Only analysis of engineering



# Local Maintenance (4)

## What does the Log message mean?

Log file 1. "error panel log0."

**[Sample]**

[<sup>①</sup>2008/ <sup>②</sup>1/ <sup>③</sup>1/01:26:34]<sup>④</sup>[<sup>⑤</sup>16/ <sup>⑥</sup>61/ <sup>⑦</sup>513/ 61/3/ 447000000]

[0x00000000/0x0006/0x0201/0x0000/0x00b7/0x00b0/0x00b1/0x80/0x81/eng]

**① Date and time** : year, month, day, hour, minute, second  
In this sample, this message means January 1st 2008 and 1:26 and 34 seconds

**② Error status** : 1=No program, 2=Not tuner lock, 4=No PAT, 8=No PMT  
16=Scramble Channel,32=No audio or no video stream.  
In this sample,16 means received scramble channel.

**③ Major channel, ④ Minor Channel, ⑤ Actual channel**

**⑥ Modulate** : 0 = VSB, 1=64QAM, 2=256QAM, 3=QAM  
In this sample 3 means QAM

Please ignore other data except the one above.

# Local Maintenance (5)

## What does the Log message mean?

Log file 5. "svl.log."

Under developing

[Sample]

① [2008/ 1/ 1/01:26:34] ② [DO/ T / 3 /46 / L / OK / U / 1 /0xAFFA / 0xFFBB / 0xFBCA  
③ ④ ⑤ ⑥ ⑦ ⑧ ⑨ ⑩ ⑪ ⑫

### ① Auto Scan start time

This sample is Jan. 1<sup>st</sup>. 1,26 and 34 seconds in 2008

### ② Auto Scan mode

ALL : All scan  
DO : Digital only  
AO : Analogue Only

### ③ Antenna

T : Terrestrial  
C : Cable

### ④ Actual tunnel

### ⑤ Antenna level only digital tuning

### ⑥ SYNC Information

L : Synchronize is OK  
U : Synchronize was failure

### ⑦ Scan Information

OK : Scan was completed  
NG : Scan was impossible

### ⑧ Service Condition

U : Registered service was renewal  
S : Same service was registered yet.  
NG : Scan was impossible

### ⑨ Major number and Minor number

Major 0~99  
Minor 0~999

### ⑩ Service ID Program number

Range 0~0xFFFF

### ⑪ Source ID

Range 0~0xFFFF

### ⑫ Source hidden Information

Range 0~0xFFFF

# Local Maintenance (6)

## Copy “Local Maintenance Log data” to SD card.

We can copy the Local maintenance data to a SD card and check the data on a PC.

## How to copy “Local maintenance Log data” to a SD card. (TV set → SD card)

1. Make new operation file of SD card.
2. Open the new txt file and name “localmainte. pwd”  
Please make only one file In the SD card.  
If there are some files in the SD card, it will cause trouble or operation error.
3. Power ON the TV.
4. Insert the SD card with file into the SD slot.
5. After this process, the copy screen will appear automatically as shown in the photo.

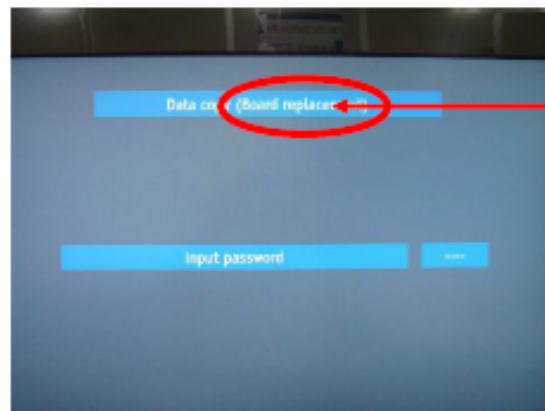

Local maintenance

## Start copying data

Input the password to start copying data.  
Press 0813 on the remote control.  
After inputting the password, copy will start.

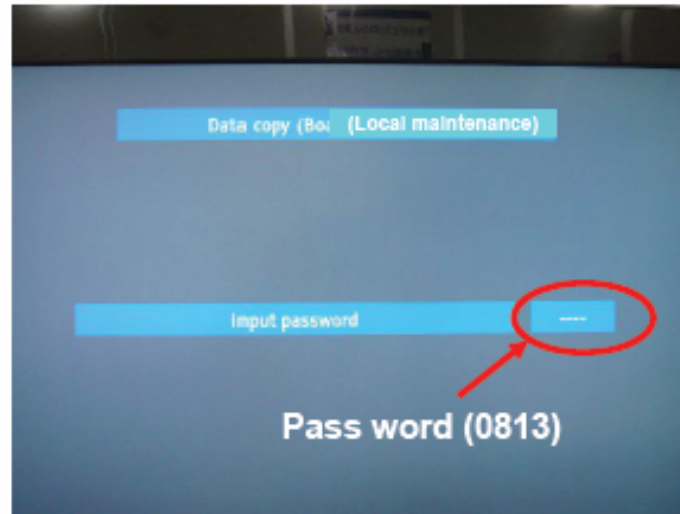

**Input Password**

### Note

There is **no** data copy function from the SD card to the TV.

## Finish copying data

When the data copy is finished, the end of copy screen will appear automatically as shown in the photo.

You can take out the SD card in this situation.

A new folder was made and new data are copied in SD card.

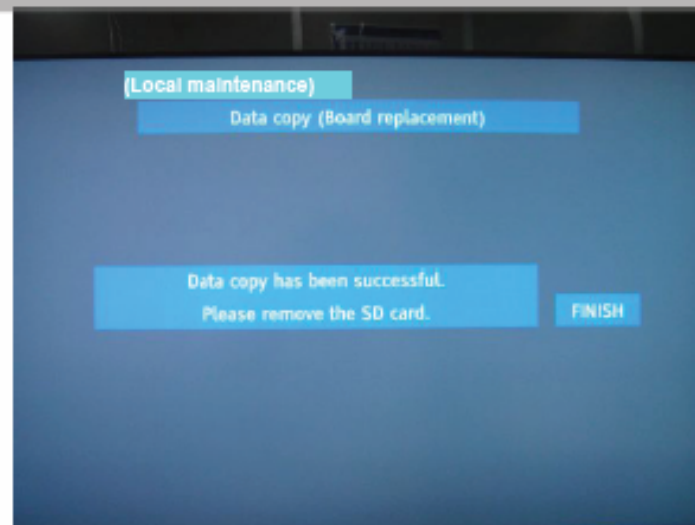

● How to log off Local maintenance = Unplug the unit

● How to clear /Refresh log data.

Same as factory shipment setting.

Press the “VOL-” button on the unit and press the “MENU” button of the remote control at the same time.

# Picture Refresh Mode

## How to enter the "Picture Refresh Mode"

- 1) First plug in from factory shipment
- 2) Press the "Volume (-)" button of the TV unit and press Channel up button 3 times on the remote control at the same time.

