

Service
Service

Service Manual

KEY BOARD - CIRCUIT DIAGRAM

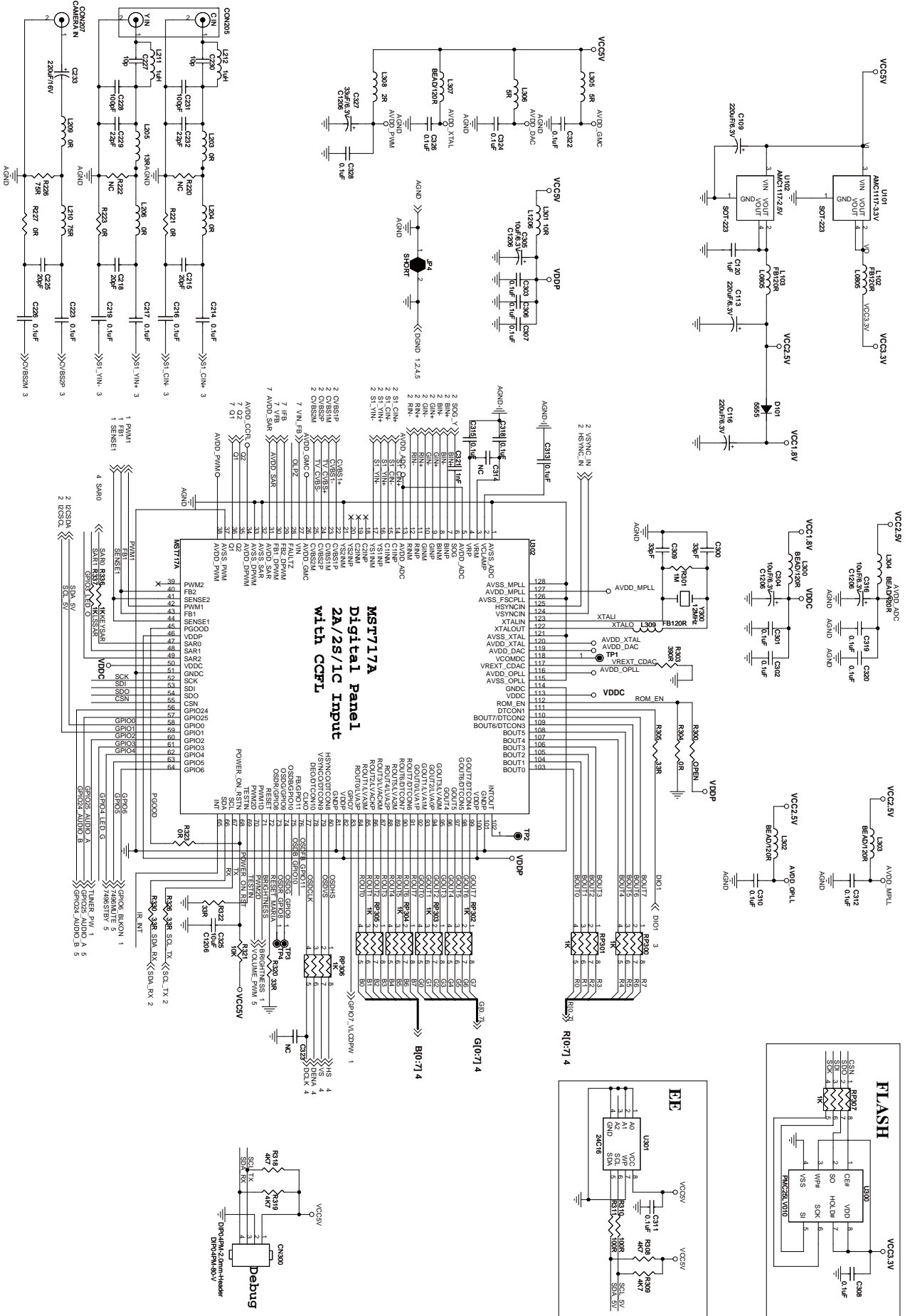

KEY BOARD - CIRCUIT DIAGRAM

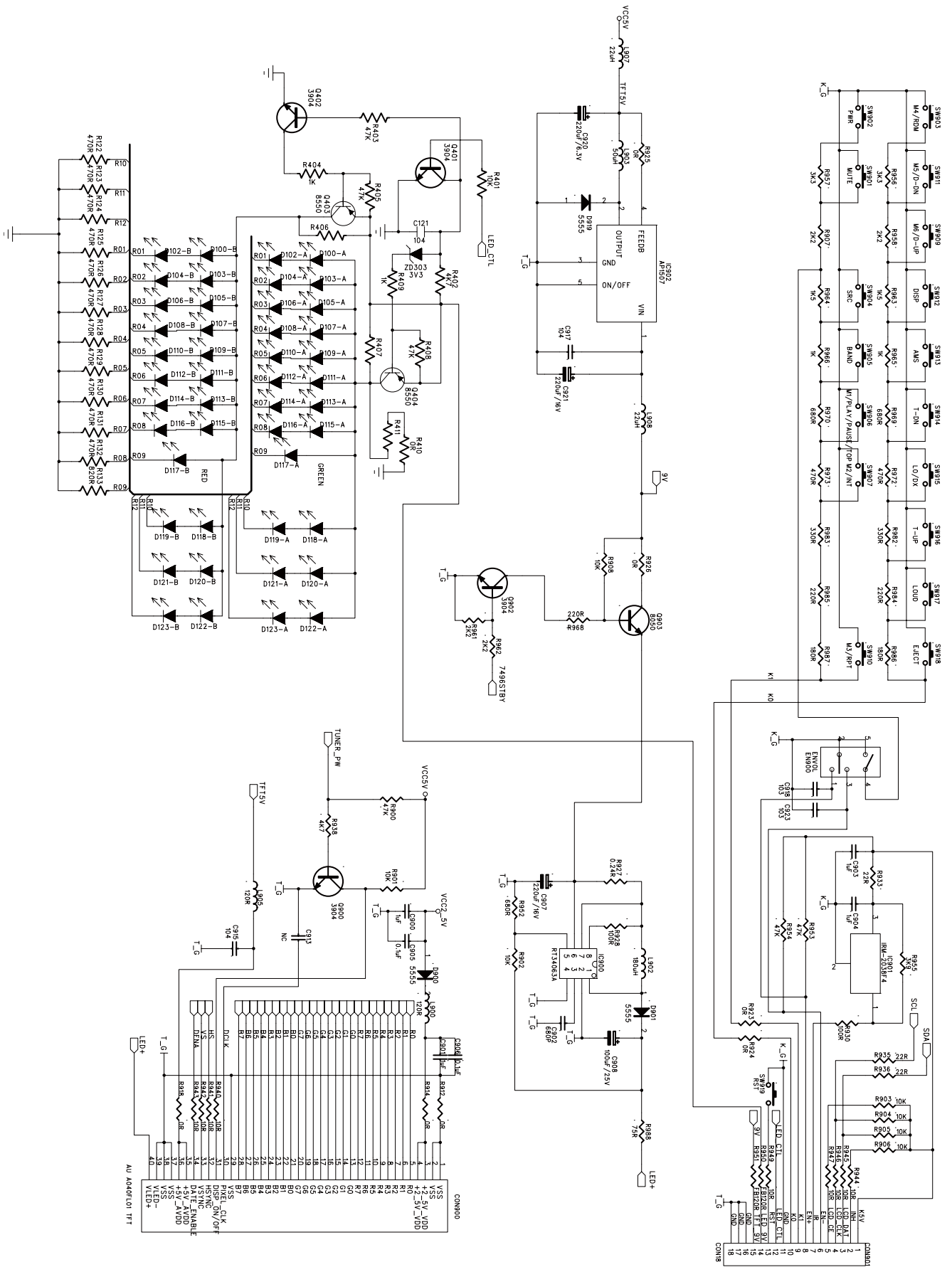

KEY BOARD - LAYOUT DIAGRAM

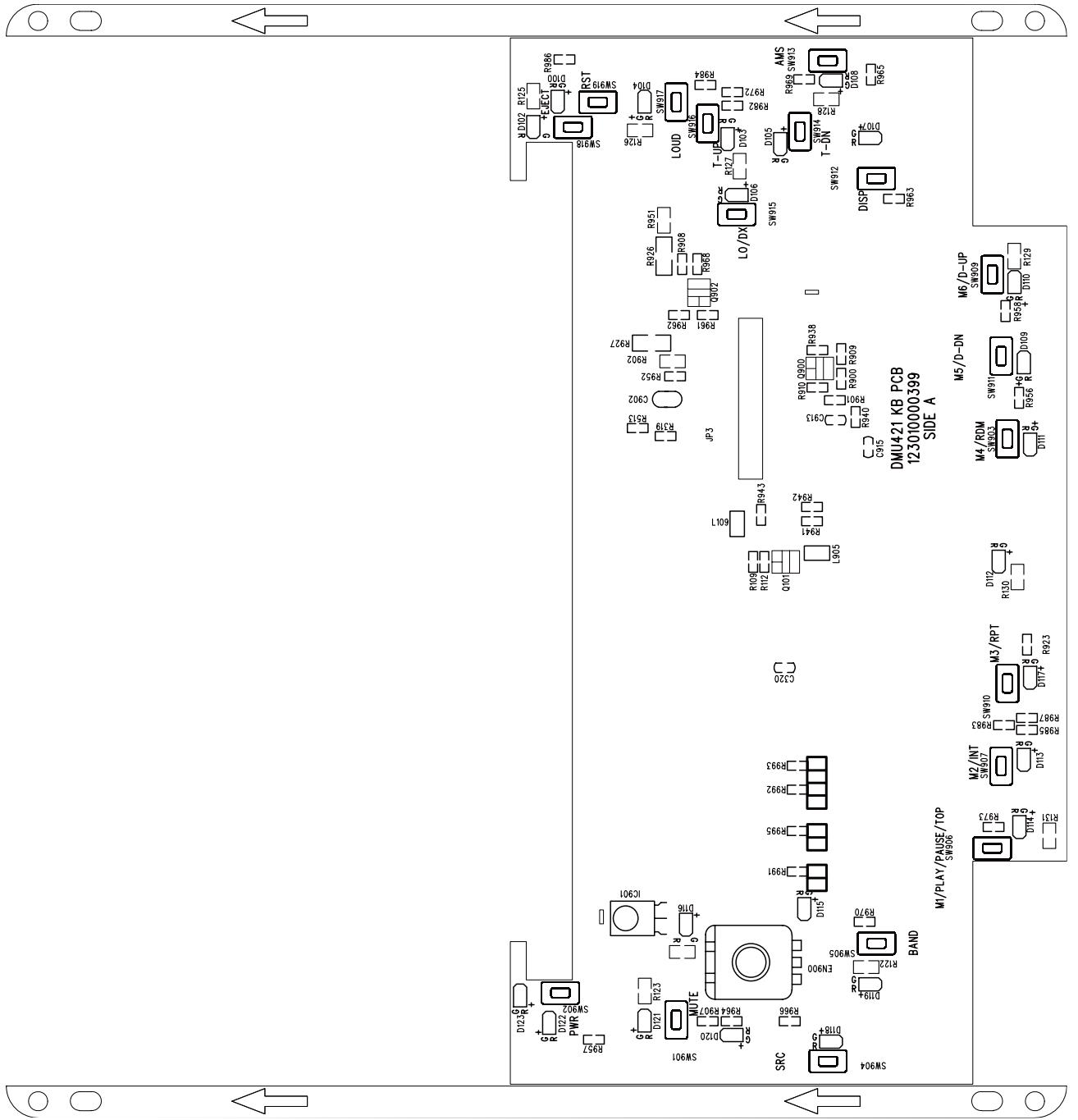

MAIN BOARD - CIRCUIT DIAGRAM

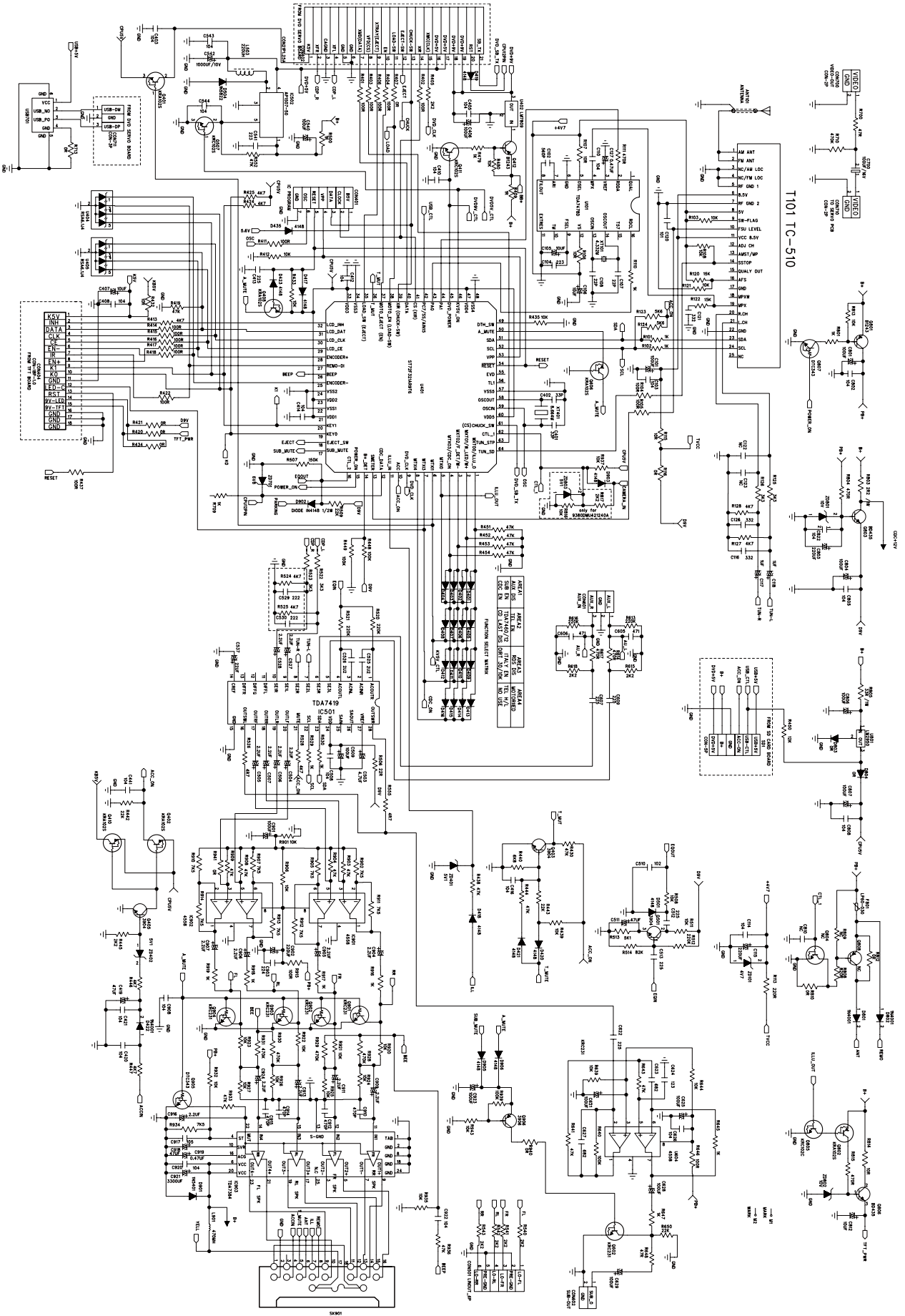

MAIN BOARD - PCB LAYOUT TOP VIEW

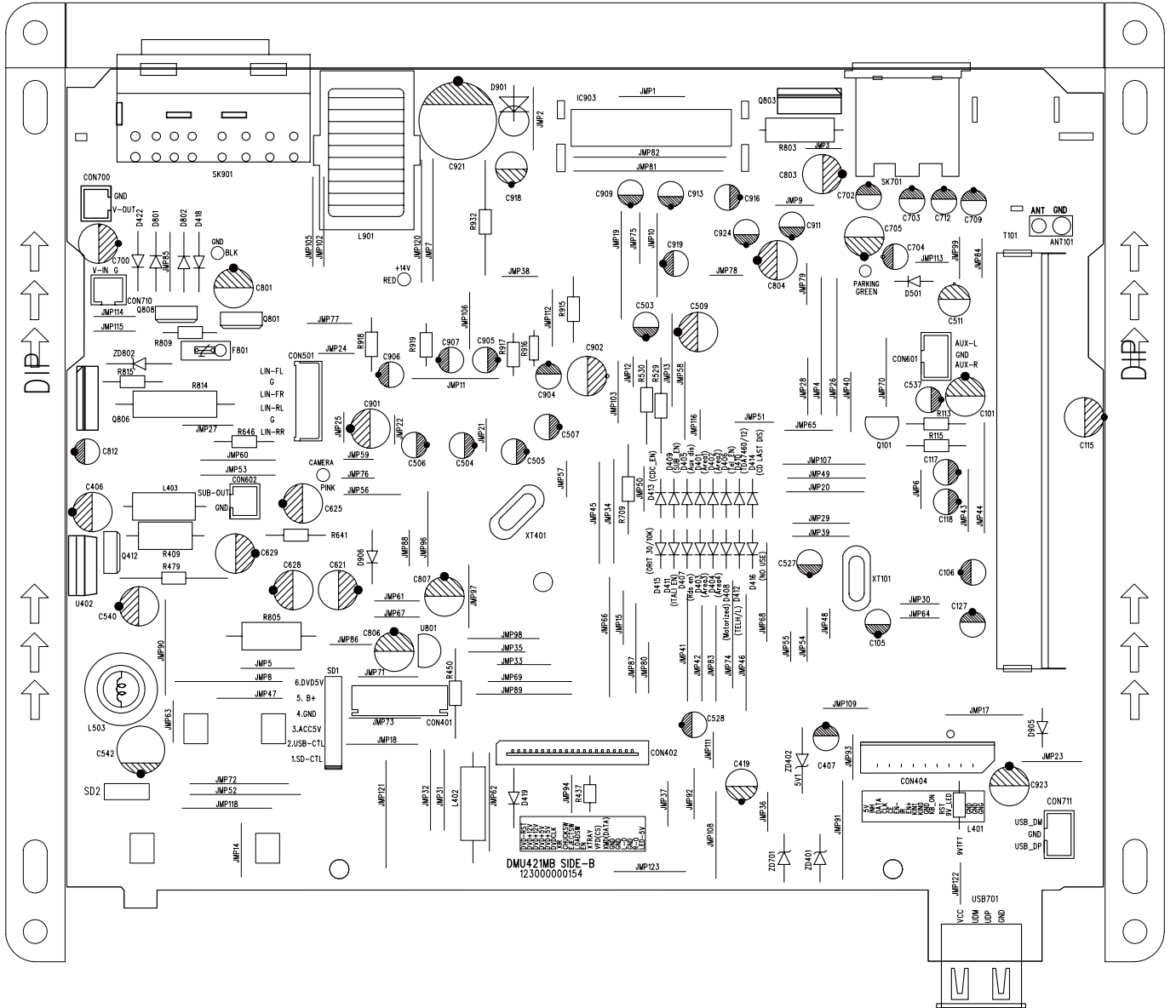

MAIN BOARD - PCB LAYOUT BOTTOM VIEW

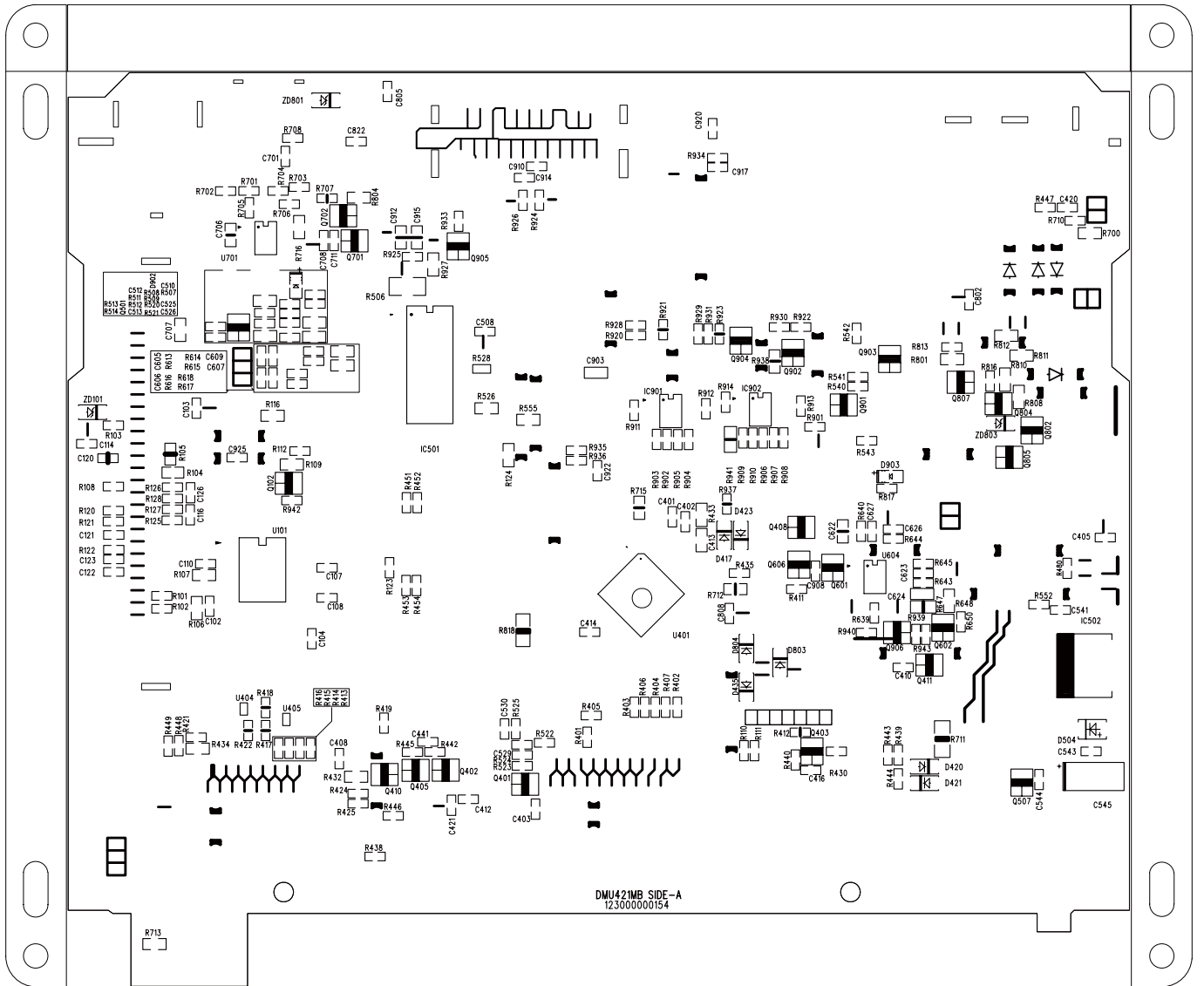

SD BOARD - CIRCUIT DIAGRAM

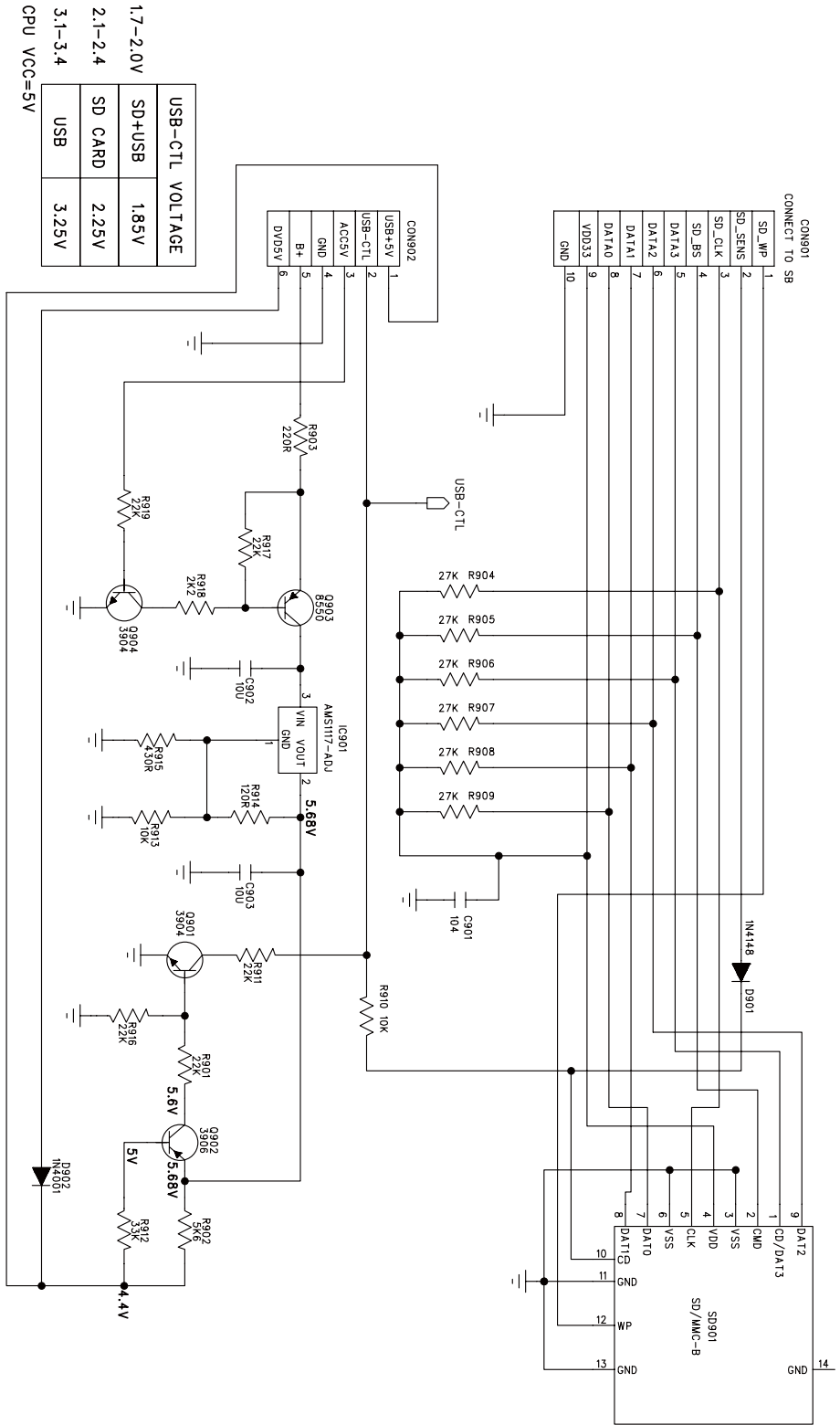

SD BOARD - LAYOUT DIAGRAM

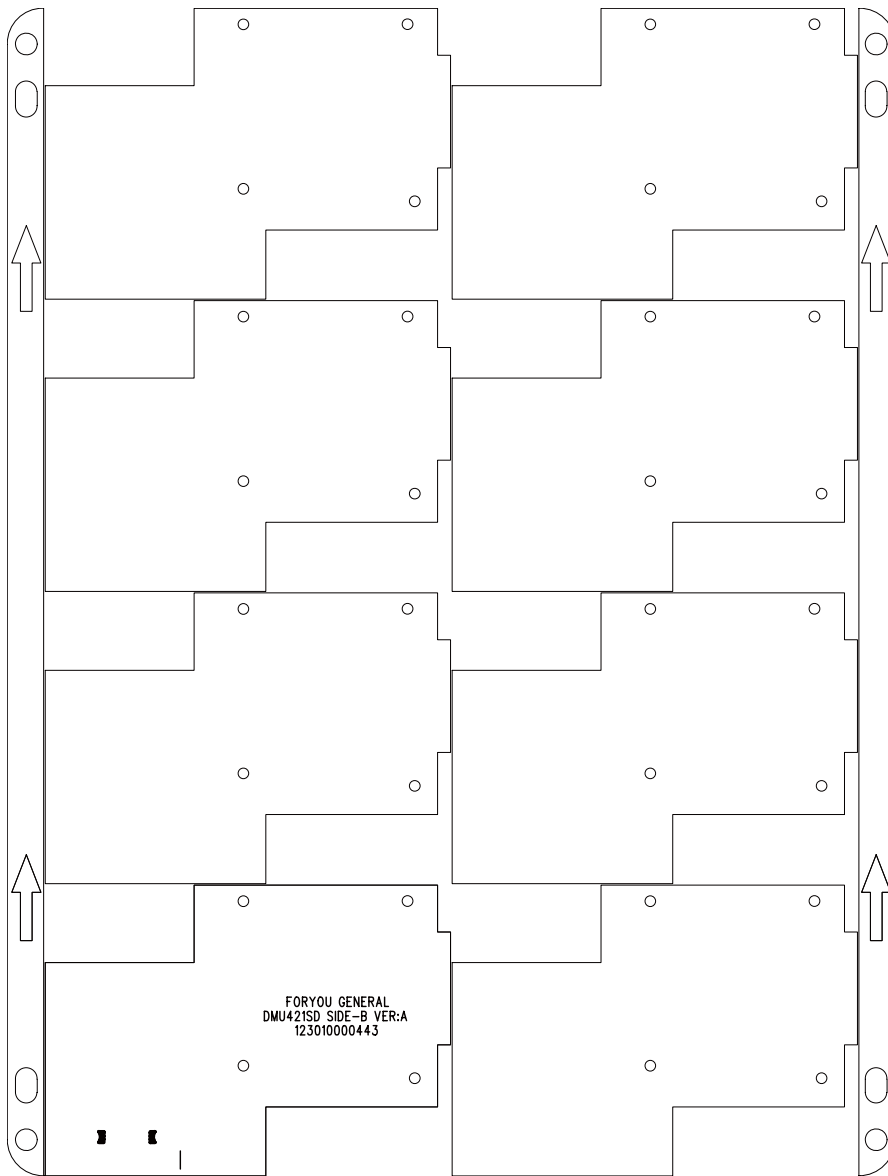

SD BOARD - LAYOUT DIAGRAM

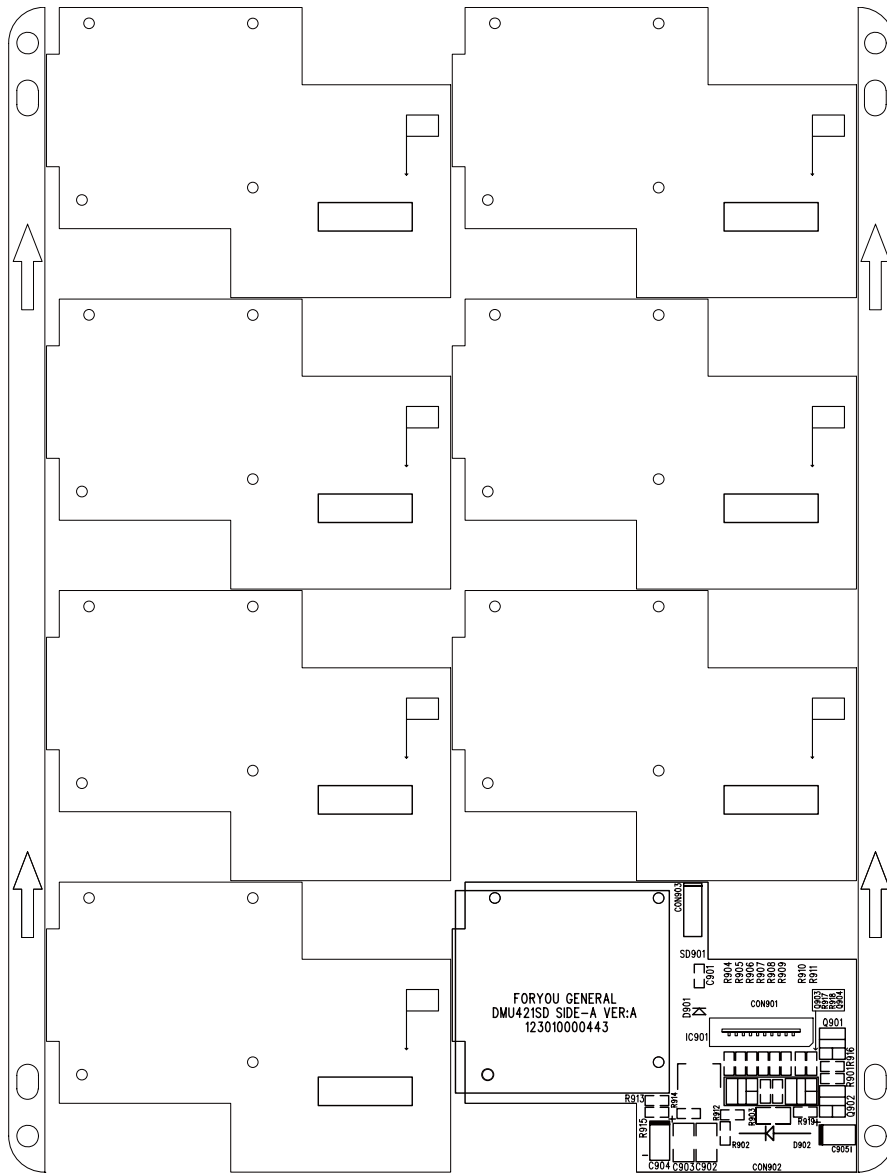

SERVO BOARD - CIRCUIT DIAGRAM

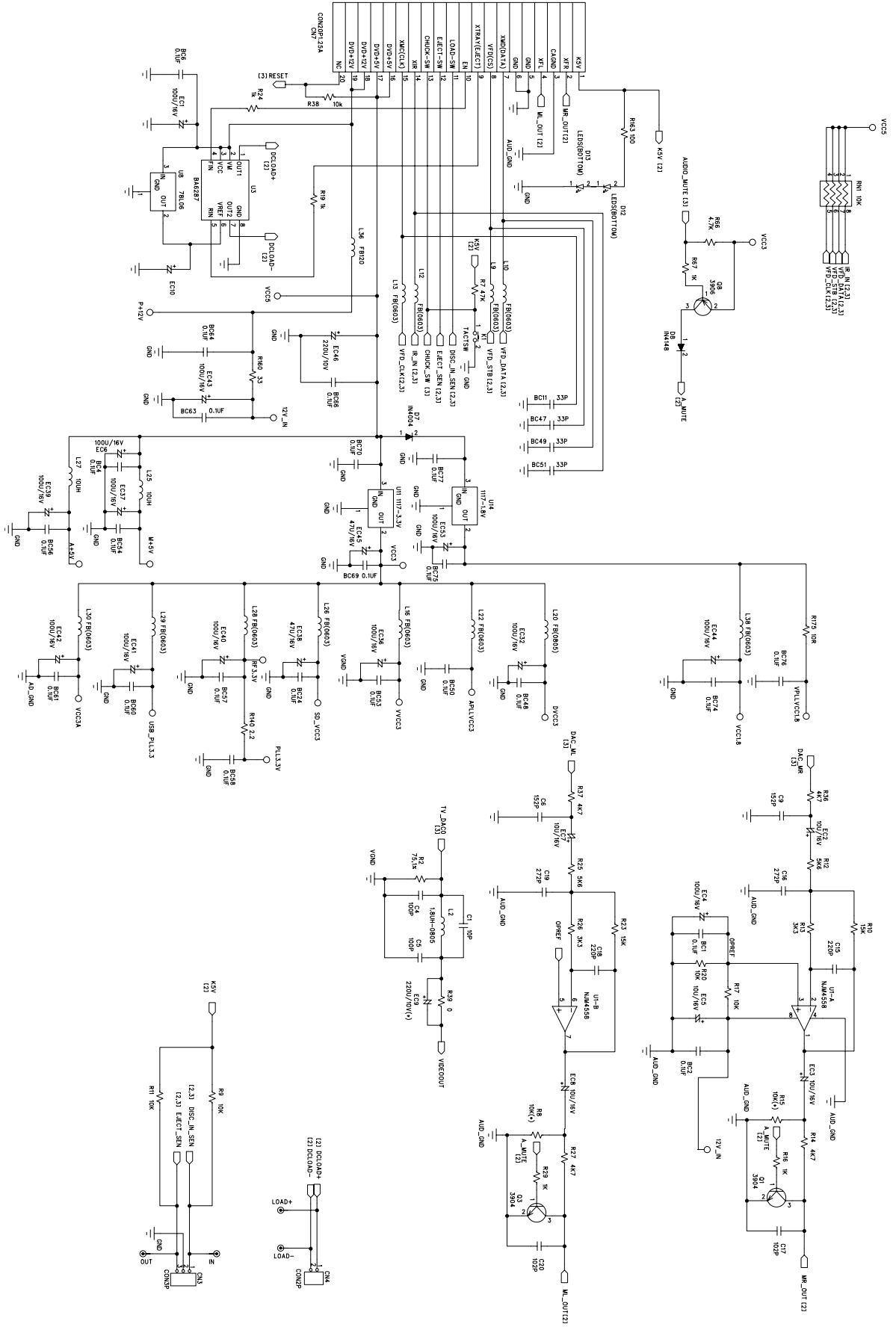

SERVO BOARD - CIRCUIT DIAGRAM

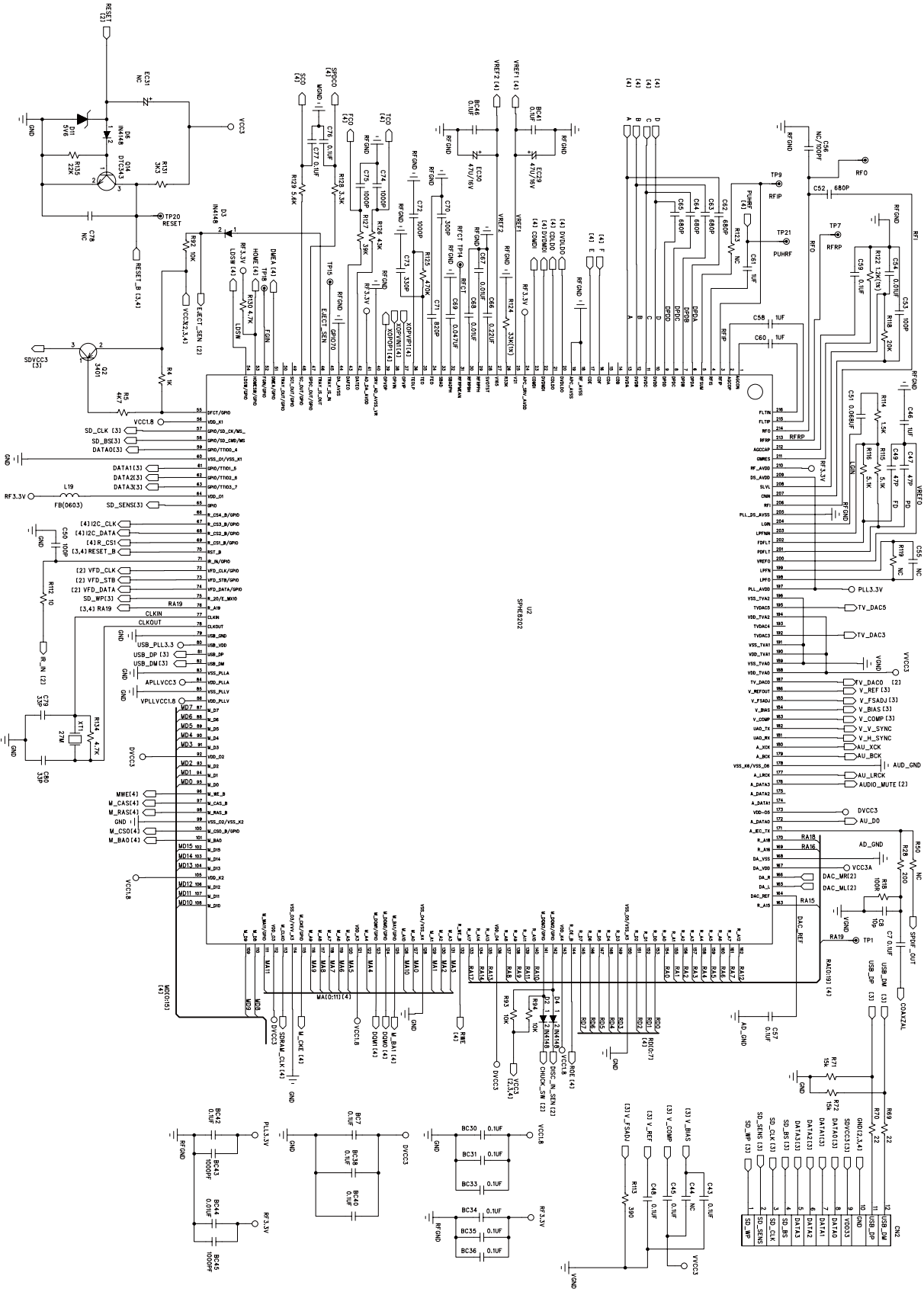

SERVO BOARD - CIRCUIT DIAGRAM

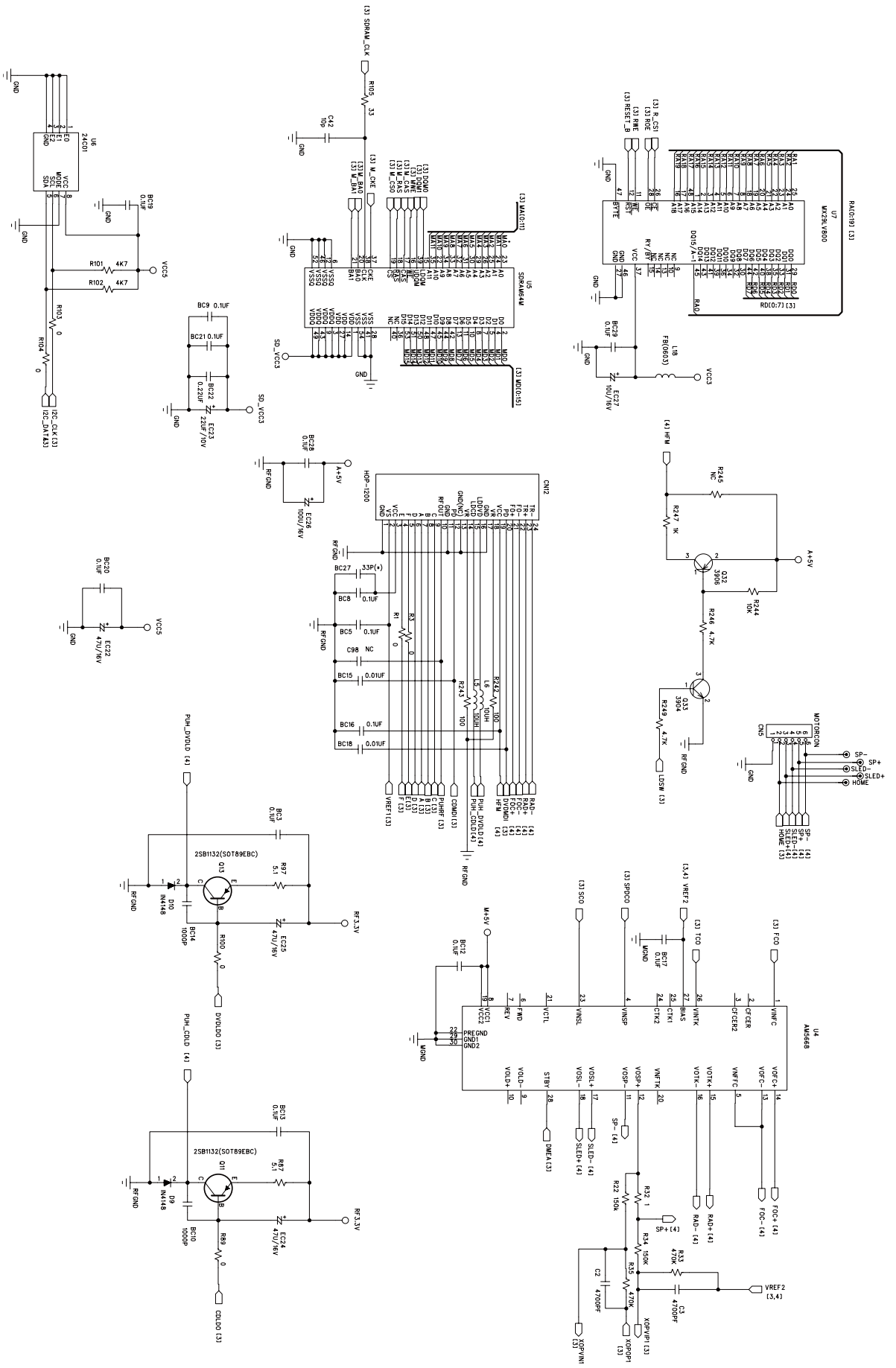

SERVO BOARD - LAYOUT DIAGRAM TOP VIEW

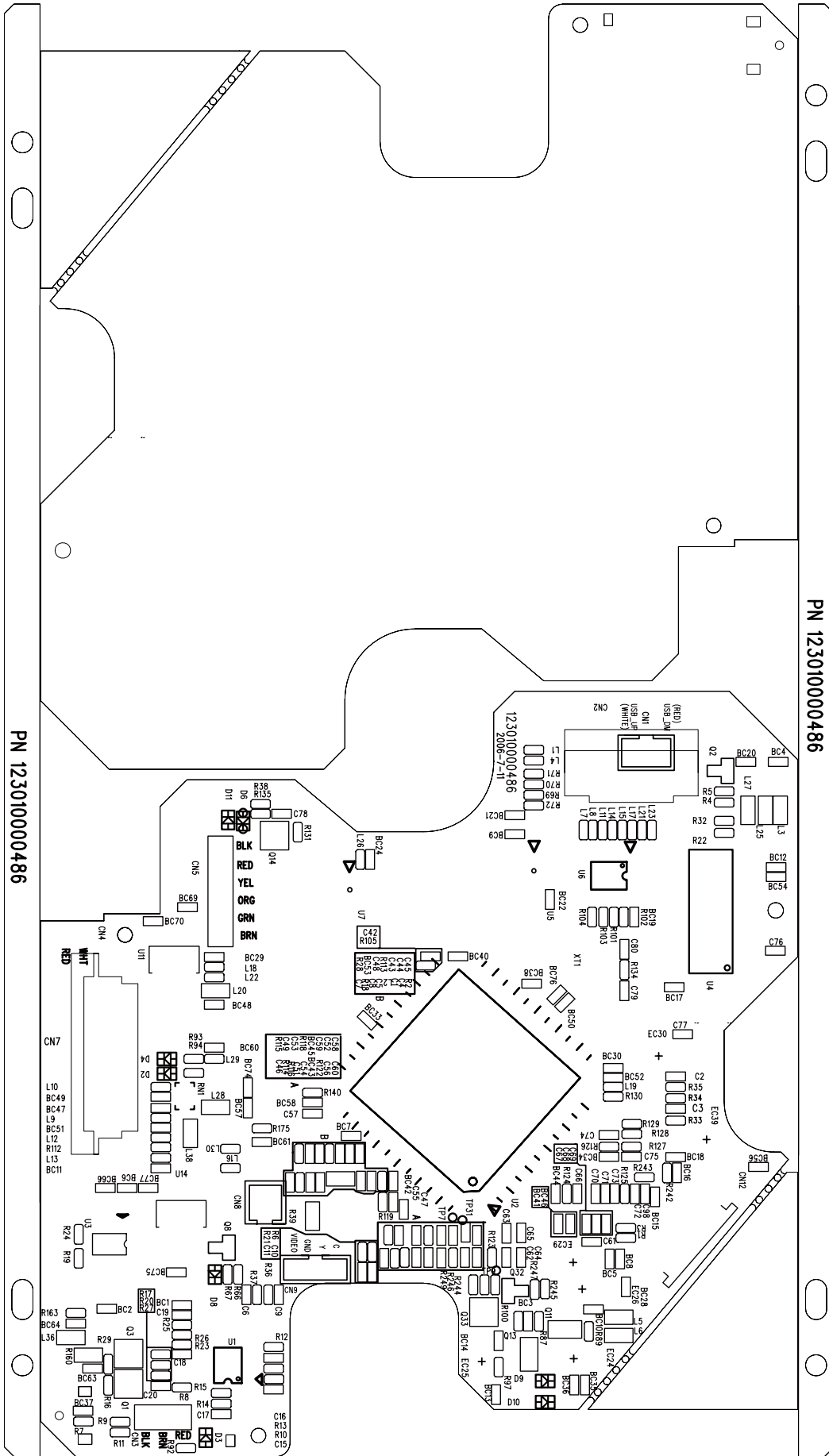

SERVO BOARD - LAYOUT DIAGRAM BOTTOM VIEW

