

# COMPACT DISC PLAYER CDX-497/CDX-397

## SERVICE MANUAL

### IMPORTANT NOTICE

This manual has been provided for the use of authorized YAMAHA Retailers and their service personnel. It has been assumed that basic service procedures inherent to the industry, and more specifically YAMAHA Products, are already known and understood by the users, and have therefore not been restated.

**WARNING:** Failure to follow appropriate service and safety procedures when servicing this product may result in personal injury, destruction of expensive components, and failure of the product to perform as specified. For these reasons, we advise all YAMAHA product owners that any service required should be performed by an authorized YAMAHA Retailer or the appointed service representative.

**IMPORTANT:** The presentation or sale of this manual to any individual or firm does not constitute authorization, certification or recognition of any applicable technical capabilities, or establish a principle-agent relationship of any form.

The data provided is believed to be accurate and applicable to the unit(s) indicated on the cover. The research, engineering, and service departments of YAMAHA are continually striving to improve YAMAHA products. Modifications are, therefore, inevitable and specifications are subject to change without notice or obligation to retrofit. Should any discrepancy appear to exist, please contact the distributor's Service Division.

**WARNING:** Static discharges can destroy expensive components. Discharge any static electricity your body may have accumulated by grounding yourself to the ground buss in the unit (heavy gauge black wires connect to this buss).

**IMPORTANT:** Turn the unit OFF during disassembly and part replacement. Recheck all work before you apply power to the unit.

CDX-497/CDX-397

## ■ CONTENTS

TO SERVICE PERSONNEL .....	2-4	DISASSEMBLY PROCEDURES / 分解手順 .....	11-12
PREVENTION OF ELECTROSTATIC DISCHARGE ....	5	TEST MODE / テストモード .....	13-14
FRONT PANELS .....	6	IC DATA .....	15-19
REAR PANELS .....	6-8	BLOCK DIAGRAM .....	20
REMOTE CONTROL PANELS .....	8	WIRING DIAGRAM .....	21
SPECIFICATIONS / 参考仕様 .....	9	PRINTED CIRCUIT BOARDS .....	22-24
INTERNAL VIEW .....	9	SCHEMATIC DIAGRAMS .....	25-26
REPAIR NOTES / 修理上の留意点 .....	10	REPLACEMENT PARTS LIST .....	28-29
HOW TO MANUALLY EJECT THE TRAY / 手動でトレイを開く方法 .....	10	REMOTE CONTROL .....	30



このサービスマニュアルは、エコマーク認定の再生紙を使用しています。  
This Service Manual uses recycled paper.

101016

© 2006 YAMAHA CORPORATION All rights reserved.  
This manual is copyrighted by YAMAHA and may not be copied or  
redistributed either in print or electronically without permission.



# YAMAHA

YAMAHA CORPORATION  
P.O.Box 1, Hamamatsu, Japan

06.07

## ■ TO SERVICE PERSONNEL

### 1. Critical Components Information

Components having special characteristics are marked  $\Delta$  and must be replaced with parts having specifications equal to those originally installed.

### 2. Leakage Current Measurement (For 120V Models Only)

When service has been completed, it is imperative to verify that all exposed conductive surfaces are properly insulated from supply circuits.

- Meter impedance should be equivalent to 1500 ohms shunted by 0.15 $\mu$ F.

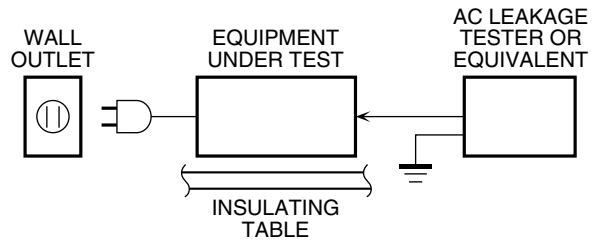

- Leakage current must not exceed 0.5mA.
- Be sure to test for leakage with the AC plug in both polarities.

## WARNING: CHEMICAL CONTENT NOTICE!

The solder used in the production of this product contains LEAD. In addition, other electrical/electronic and/or plastic (where applicable) components may also contain traces of chemicals found by the California Health and Welfare Agency (and possibly other entities) to cause cancer and/or birth defects or other reproductive harm.

DO NOT PLACE SOLDER, ELECTRICAL/ELECTRONIC OR PLASTIC COMPONENTS IN YOUR MOUTH FOR ANY REASON WHATSOEVER!

Avoid prolonged, unprotected contact between solder and your skin! When soldering, do not inhale solder fumes or expose eyes to solder/flux vapor!

If you come in contact with solder or components located inside the enclosure of this product, wash your hands before handling food.

## About Lead Free Solder / 無鉛ハンダについて

All of the P.C.B.s installed in this unit are soldered using the lead free solder.

Among some types of lead free solder currently available, it is recommended to use one of the following types for the repair work.

- Sn + Ag + Cu (tin + silver + copper)
- Sn + Cu (tin + copper)
- Sn + Zn + Bi (tin + zinc + bismuth)

本機に搭載されているすべての基板は無鉛ハンダでハンダ付けされています。

無鉛ハンダにはいくつかの種類がありますが、修理時には下記のような無鉛ハンダの使用を推奨します。

- Sn+Ag+Cu (錫+銀+銅)
- Sn+Cu (錫+銅)
- Sn+Zn+Bi (錫+亜鉛+ビスマス)

### Caution:

As the melting point temperature of the lead free solder is about 30°C to 40°C (50°F to 70°F) higher than that of the lead solder, be sure to use a soldering iron suitable to each solder.

### 注意：

無鉛ハンダの融点温度は通常の鉛入りハンダに比べ30～40℃程度高くなっていますので、それぞれのハンダに合ったハンダごてをご使用ください。

## WARNING: Laser Safety

This product contains a laser beam component. This component may emit invisible, as well as visible radiation, which may cause eye damage. To protect your eyes and skin from laser radiation, the following precautions must be used during servicing of the unit.

- 1) When testing and/or repairing any component within the product, keep your eyes and skin more than 30 cm away from the laser pick-up unit at all times. Do not stare at the laser beam at any time.
- 2) Do not attempt to readjust, disassemble or repair the laser pick-up, unless noted elsewhere in this manual.
- 3) CAUTION: Use of controls, adjustments or performance of procedures other than those specified herein may result in hazardous radiation exposure.

## Laser Emitting conditions:

- 1) When the top cover is removed, and the "STANDBY/ON" SW is turned to the "ON" position, the laser component will emit a beam for several seconds to detect if a disc is present. During this time (5-10 sec.) the laser may radiate through the lens of the laser pick-up unit. Do not attempt any servicing during this period!

If no disc is detected, the laser will stop emitting the beam. When a disc is set, you will not be exposed to any laser emissions.

2) The laser power level can be adjusted with the VR on the pick-up PWB. However, this level has been set by the factory prior to shipping from the factory. Do not adjust this laser level control unless instruction is provided elsewhere in this manual. Adjustment of this control can increase the laser emission level from the device.

## Laser Diode Properties

Material: GaAlAs  
 Wavelength: 780 nm  
 Emission duration: continuous  
 Laser output: max. 44.6  $\mu$ W \*

\* This output is the value measured at a distance of about 200 mm from the objective lens surface on the Optical Pick-up Block.

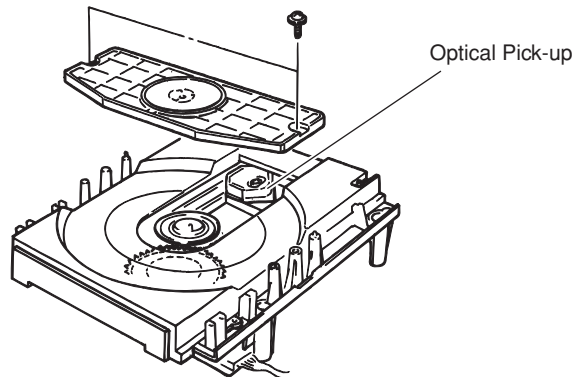

## WARNING

CAUTION	- INVISIBLE LASER RADIATION WHEN OPEN AND INTERLOCKS DEFEATED, AVOID EXPOSURE TO BEAM.
VORSICHT!	UNSICHTBARE LASERSTRAHLUNG TRITT AUS, WENN DECKEL GEÖFFNET UND WENN SICHERHEITSPERIEGELUNG ÜBERBRÜCKT IST. NICHT DEM STRAHL AUSSETZEN!
VARNING	- OSYNLIG LASERSTRÅLNING NÄR DENNA DEL ÄR ÖPPNAD OCH SPÄRR ÄR URKOPPLAD. STRÅLEN ÄR FARLIG.

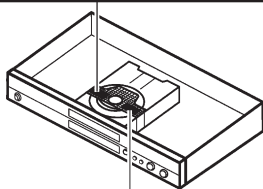

ADVARSEL	- USYNLIG LASERSTRÅLING VED ÅBNING, NÄR SIKKERHEDSAFBRYDERE ER UDE AF FUNKTION. UNDGÅ UDSÆTTELSE FOR STRÅLING.
VAROITUS!	- SUOJAKOTEL OI EI SAA AVATA. LAITE SISÄLTÄÄ LASERIODIN, JOKA LÄHETTÄÄ (NÄKYMÄTÖNTÄ) SILMILLE VAARALLISTA LASERSÄTEILYÄ.
ADVARSEL	- OSYNLIG LASERBESTRÅLING NÄR DENNE DELEN ER ÅPEN OG SIKKERHETSPERREN ER UTKOBLET. UNNGÅ UTSETTELSE FOR STRÅLING.

**CAUTION**  
 VISIBLE AND INVISIBLE LASER RADIATION WHEN OPEN. AVOID EXPOSURE TO BEAM.

**ADVARSEL**  
 SYNLIG OG USYNLIG LASERSTRÅLING VED ÅBNING. UNDGÅ UDSÆTTELSE FOR STRÅLING.

**ADVARSEL**  
 SYNLIG OG USYNLIG LASERSTRÅLING NÄR DEKSEL ÅPNES. UNNGÅ EKSPONERING FOR STRÅLEN.

**VARNING**  
 SYNLIG OCH OSYNLIG LASERSTRÅLNING NÄR DENNA DEL ÄR ÖPPNAD. BETRakta EJ STRÅLEN.

**VARO!**  
 AVATTAESSÄ OLET ALTTIINA NÄKYVÄLLE JA NÄKYMÄTTÖMÄLLE LASER SÄ TEILYLLE. ÄLÄ KATSO SÄTEESEEN.

**VORSICHT**  
 SICHTBARE UND UNSICHTBARE LASERSTRAHLUNG WENN ABDECKUNG GEÖFFNET. NICHT DEM STRAHL AUSSETZEN.

**DANGER**  
 VISIBLE AND INVISIBLE LASER RADIATION WHEN OPEN. AVOID DIRECT EXPOSURE TO BEAM.

**ATTENTION**  
 RAYONNEMENT LASER VISIBLE ET INVISIBLE EN CAS D'OUVERTURE. EXPOSITION DANGEREUSE AU FAISCEAU.

**ПРЕДУПРЕЖДЕНИЕ**  
 ПРИ ОТКРЫТИИ УСТРОЙСТВА ВЫ МОЖЕТЕ ПОДВЕРГНУТЬСЯ ВОЗДЕЙСТВИЮ ВИДИМОГО И НЕВИДИМОГО ЛАЗЕРНОГО ИЗЛУЧЕНИЯ. ИЗБЕГАЙТЕ ВОЗДЕЙСТВИЯ ЛУЧА.

**注意**  
 打开时存在可见或不可见的激光辐射。应避免被激光光束照射。

**CAUTION**

Use of controls or adjustments or performance of procedures other than those specified herein may result in hazardous radiation exposure.

**ATTENTION**

L'emploi de commandes, de réglages ou un choix de procédures différents des spécifications de cette brochure peut entraîner une exposition à d'éventuelles radiations pouvant être dangereuses.

**ACHTUNG**

Die Verwendung von Bedienungselementen oder Einstellungen oder die Durchführung von Bedienungsvorgängen, die nicht in dieser Anleitung aufgeführt sind, kann zu einem Kontakt mit gefährlichen Laserstrahlen führen.

**OBSERVERA**

Användning av kontroller och justeringar eller genomförande av procedurer andra än de som specificeras i denna bok kan resultera i att du utsätter dig för farlig strålning.

**ATTENZIONE**

Uso di controlli o regolazioni o procedure non specificamente descritte può causare l'esposizione a radiazioni di livello pericoloso.

**PRECAUCIÓN**

El uso de los controles o los procedimientos de ajuste o utilización diferentes de los especificados en este manual pueden causar una exposición peligrosa a la radiación.

**VOORZICHTIG**

Gebruik van bedieningsorganen of instellingen, of uitvoeren van handelingen anders dan staan beschreven in deze handleiding kunnen leiden tot blootstelling aan gevaarlijke stralen.

**ПРЕДУПРЕЖДЕНИЕ**

Использование органов управления или настроек или выполнение процедур, отличных от описанных в данном руководстве, могут привести к опасному облучению.

**注意**

使用此处指定外的控制或调节以及进行指定外的操作都有可能引起有害的辐射暴露。

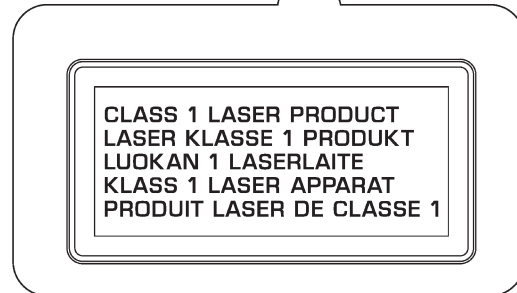
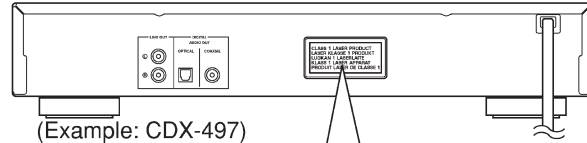
**VARO!**

AVATTAESSA JA SUOJALUKITUS OHITETTAESSA OLET ALTTIINA NÄKYMÄTTÖMÄLLE LASERSÄTEILYLLE. ÄLÄ KATSO SÄTEESEEN.

**WARNING!**

OSYNLIG LASERSTRÅLNING NÄR DENNA DEL ÄR ÖPPNAD OCH SPÄRREN ÄR URKOPPLAD. BETRAKTA EJ STRÅLEN.

## ■ PREVENTION OF ELECTROSTATIC DISCHARGE

Some semiconductor (solid state) devices can be damaged easily by static electricity. Such components commonly are called Electrostatically Sensitive (ES) Devices. Examples of typical ES devices are integrated circuits and some field-effect transistors and semiconductor “chip” components. The following techniques should be used to help reduce the incidence of component damage caused by electro static discharge (ESD).

1. Immediately before handling any semiconductor component or semiconductor-equipped assembly, drain off any ESD on your body by touching a known earth ground. Alternatively, obtain and wear a commercially available discharging ESD wrist strap, which should be removed for potential shock reasons prior to applying power to the unit under test.
2. After removing an electrical assembly equipped with ES devices, place the assembly on a conductive surface such as aluminum foil, to prevent electrostatic charge buildup or exposure of the assembly.
3. Use only a grounded-tip soldering iron to solder or unsolder ES devices.
4. Use only an anti-static solder removal device. Some solder removal devices not classified as “anti-static (ESD protected)” can generate electrical charge sufficient to damage ES devices.
5. Do not use freon-propelled chemicals. These can generate electrical charges sufficient to damage ES devices.
6. Do not remove a replacement ES device from its protective package until immediately before you are ready to install it. (Most replacement ES devices are packaged with leads electrically shorted together by conductive foam, aluminum foil or comparable conductive material).
7. Immediately before removing the protective material from the leads of a replacement ES device, touch the protective material to the chassis or circuit assembly into which the device will be installed.  
CAUTION: Be sure no power is applied to the chassis or circuit, and observe all other safety precautions.
8. Minimize bodily motions when handling unpackaged replacement ES devices. (Otherwise harmless motion such as the brushing together of your clothes fabric or the lifting of your foot from a carpeted floor can generate static electricity (ESD) sufficient to damage an ES device).

### Grounding for electrostatic breakdown prevention

1. Human body grounding.  
Use the antistatic wrist strap to discharge the static electricity from your body.
2. Work table grounding.  
Put a conductive material (sheet) or steel sheet on the area where the optical pickup is placed and ground the sheet.

#### Caution:

The static electricity of your clothes will not be grounded through the wrist strap. So take care not to let your clothes touch the optical pickup.

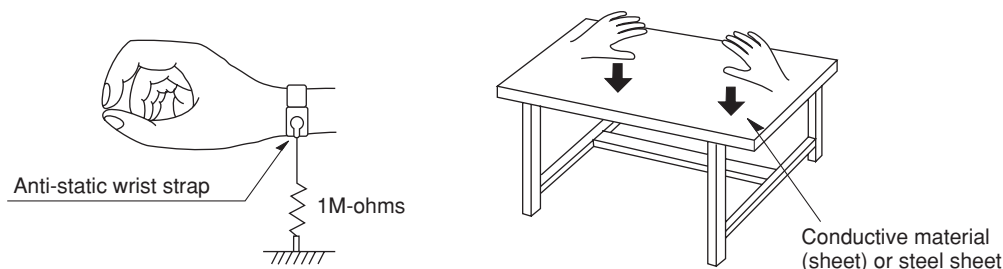

## FRONT PANELS

CDX-497 (R, T, K, A, B, G, J models)

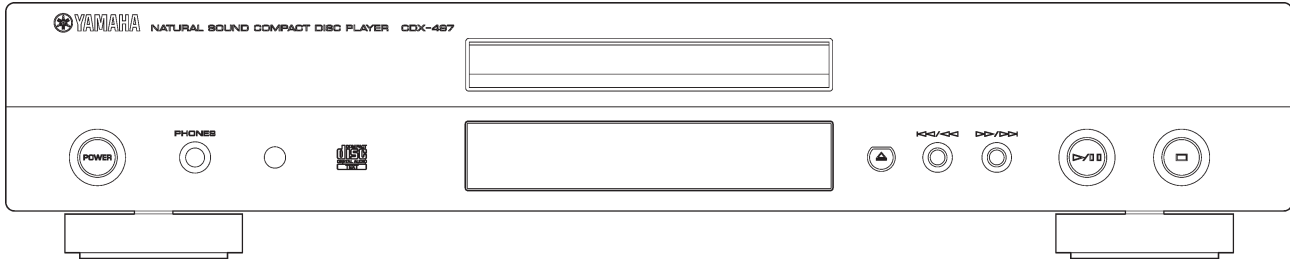

CDX-397 (R, T, A, B, G models)

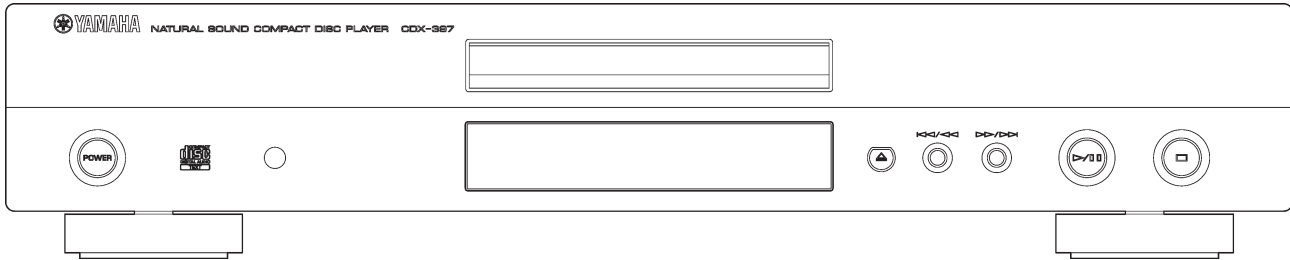

## REAR PANELS

CDX-497 (R model)

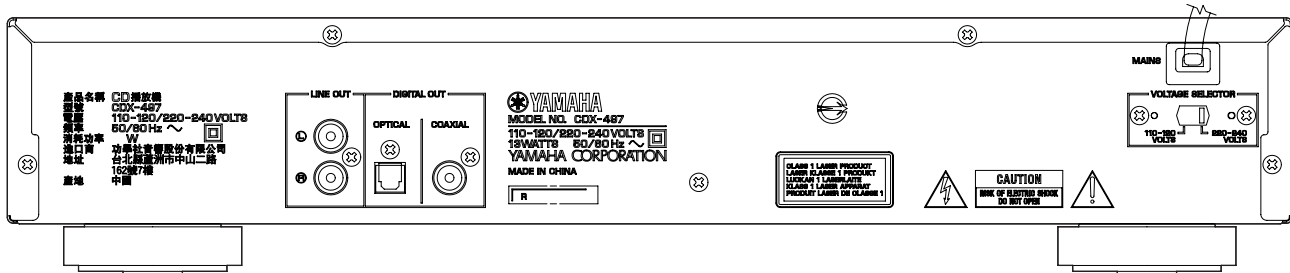

CDX-497 (T model)

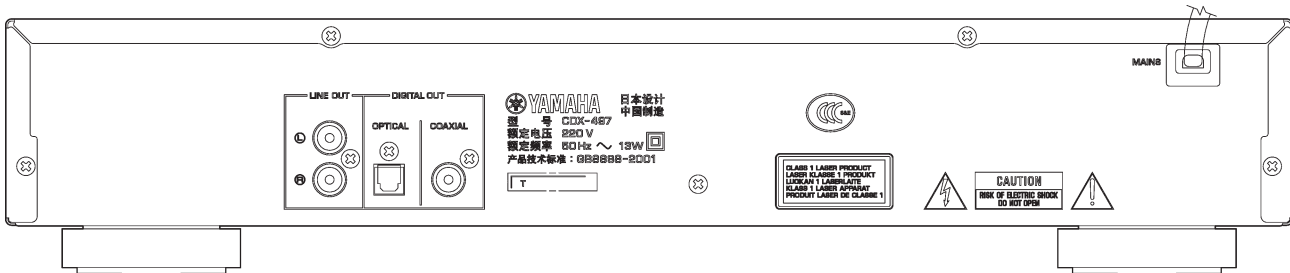

CDX-497 (K model)

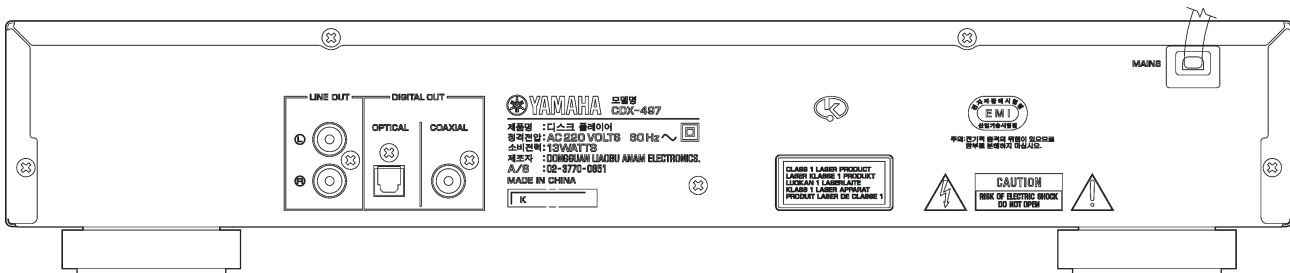

CDX-497 (A model)

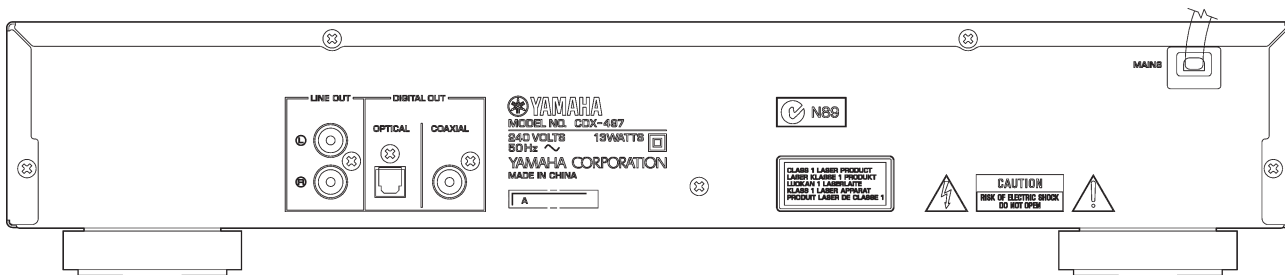

CDX-497 (B, G models)

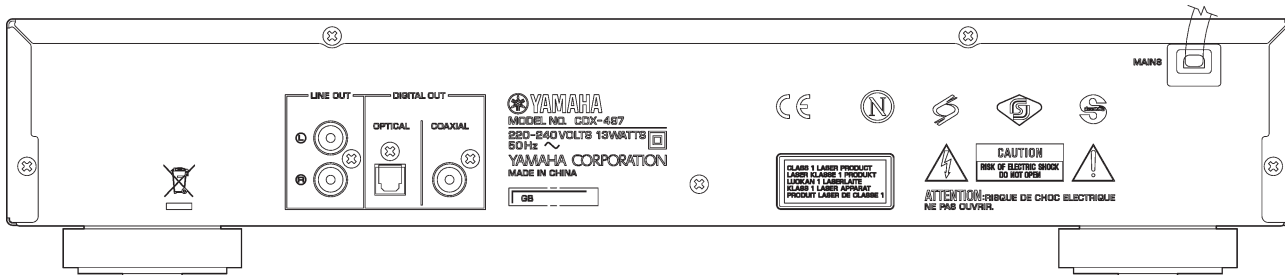

CDX-497 (J model)

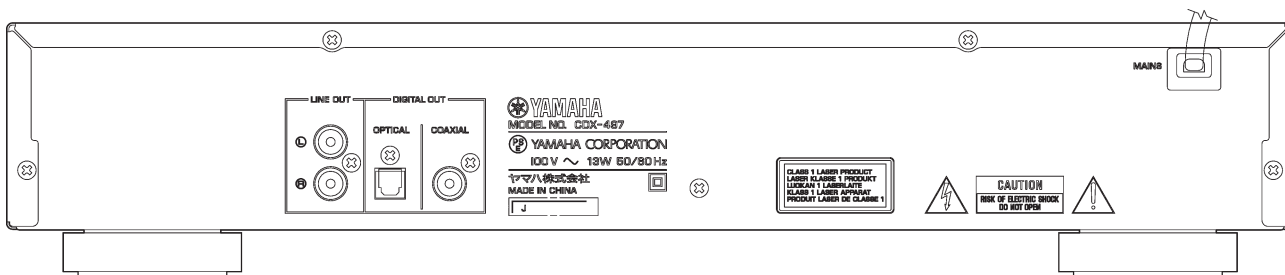

CDX-397 (R model)

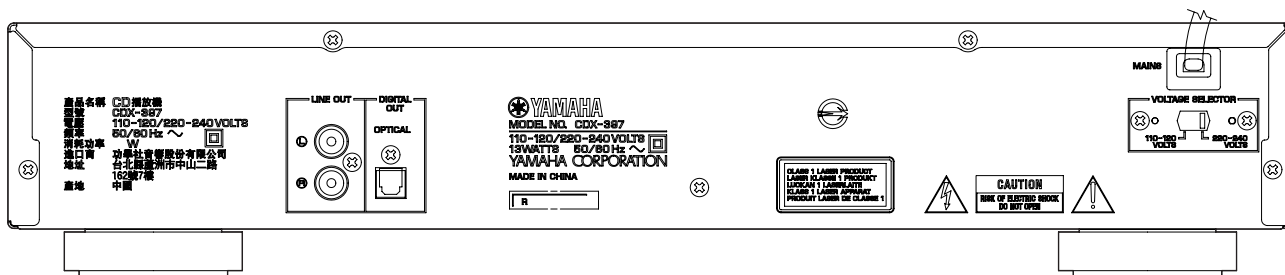

CDX-397 (T model)

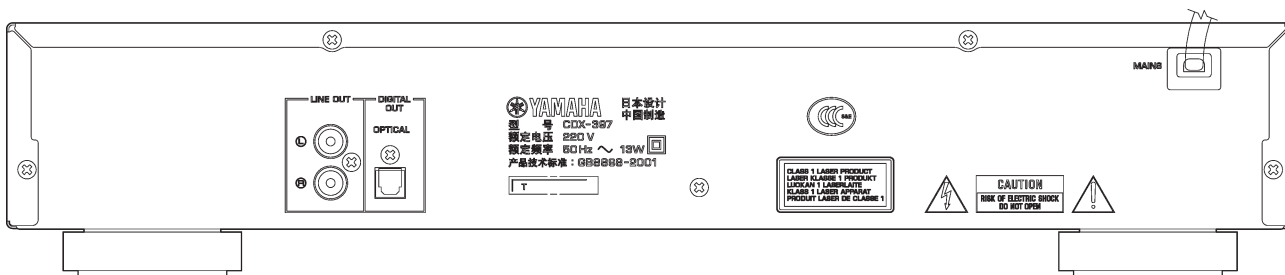

CDX-497/CDX-397

CDX-397 (A model)

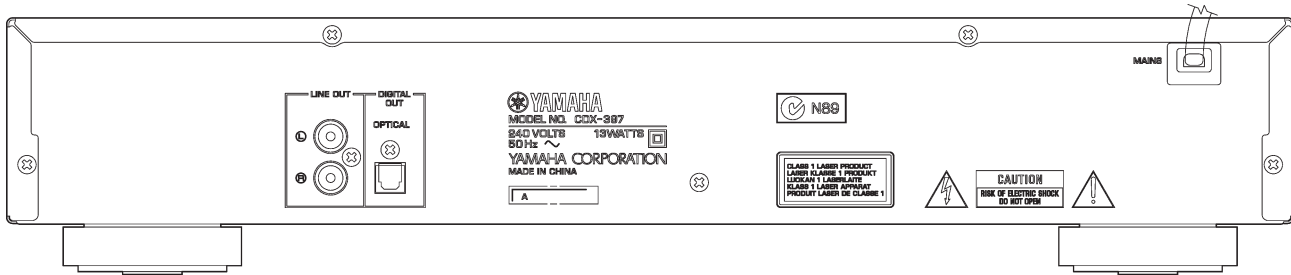

CDX-397 (B, G models)

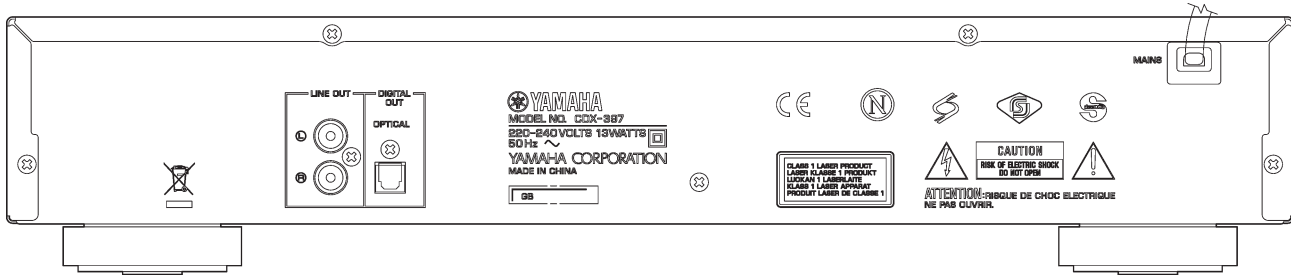

■ REMOTE CONTROL PANELS

CDX-497 (R, T, K, A, B, G, J models)

CDX-397 (R, T, A, B, G models)

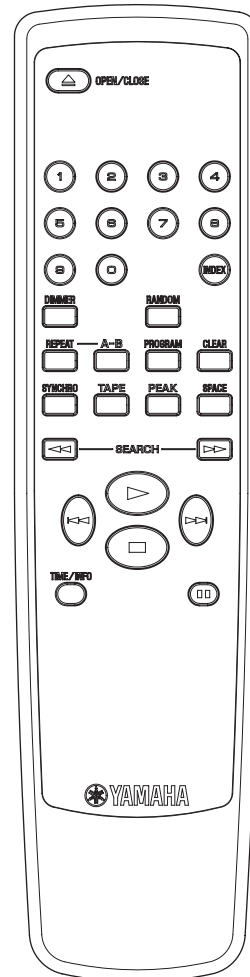
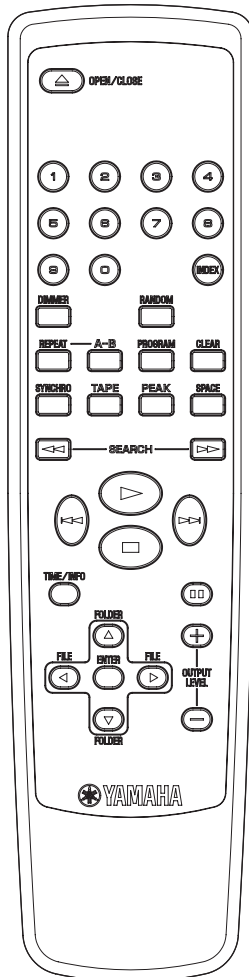

CDX-497/CDX-397



## ■ SPECIFICATIONS / 参考仕様

### ■ Audio Section / オーディオ部

#### Frequency Response / 周波数特性

..... 2 Hz to 20 kHz,  $\pm 0.5$  dB

#### Total Harmonic Distortion + Noise (1 kHz) / 高調波歪率(1 kHz)

..... 0.003 % or less

#### Signal to Noise Ratio / 信号対雑音比

..... 105 dB or more

#### Dynamic Range / ダイナミックレンジ

..... 95 dB or more

#### Output Voltage (1 kHz, 0 dB) / 出力電圧(1 kHz、0 dB)

.....  $2.0 \pm 0.5$  V

#### Headphone Output (-20 dB) / ヘッドフォン出力電圧(-20 dB)

[CDX-497 model]

.....  $750 \pm 100$  mV/32 ohms

### ■ General / 総合

#### Power Supply / 電源電圧

R model ..... AC 110-120/220-240 V, 50/60 Hz

T model ..... AC 220 V, 50 Hz

K model ..... AC 220 V, 60 Hz

A model ..... AC 240 V, 50 Hz

B, G models ..... AC 220-240 V, 50 Hz

J model ..... AC 100V, 50/60 Hz

#### Power Consumption / 消費電力

..... 13 W

#### Dimensions (W x H x D) / 寸法(幅×高さ×奥行き)

..... 435 x 87 x 287 mm (17-1/8" x 3-7/16" x 11-5/16")

#### Weight / 質量

..... 3.5 kg (7 lbs. 11 oz)

#### Finish / 仕上げ

##### [CDX-497]

Gold color ..... T, K, J models

Black color ..... R, A, G models

Titanium color ..... R, B, G models

##### [CDX-397]

Gold color ..... T model

Black color ..... R, T, A, G models

Titanium color ..... R, B, G models

### Accessories / 付属品

Remote control x 1, Batteries x 2, Audio pin cable (1.5 m) x 1

\* Specifications are subject to change without notice due to product improvements.

※ 参考仕様および外観は予告なく変更されることがあります。

R .....	General model	T .....	Chinese model
K .....	Korean model	A .....	Australian model
B .....	British model	G .....	European model
J .....	Japanese model		

### • DIMENSIONS

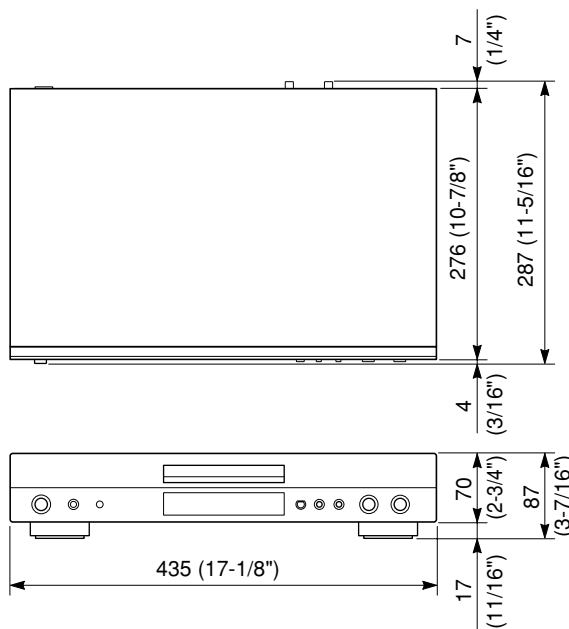

Unit: mm (inch)  
単位: mm(インチ)

## ■ INTERNAL VIEW

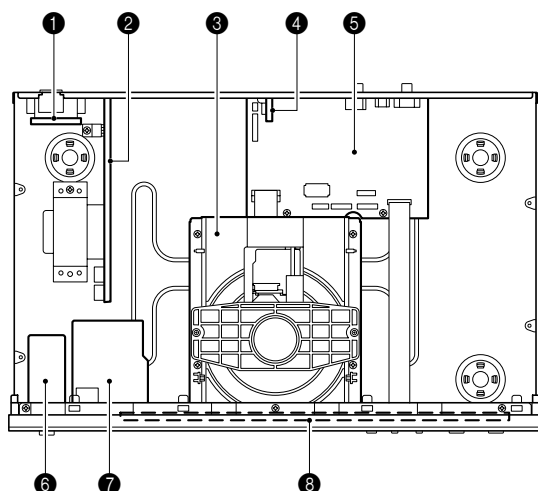

- ① FRONT (5) P.C.B. (R model)
- ② FRONT (2) P.C.B.
- ③ CD Mechanism
- ④ MAIN (2) P.C.B.
- ⑤ MAIN (1) P.C.B.
- ⑥ FRONT (4) P.C.B.
- ⑦ FRONT (3) P.C.B. (CDX-497 model)
- ⑧ FRONT (1) P.C.B.

## REPAIR NOTES / 修理上の留意点

None of the components of the following unit can be supplied separately.

Each unit must be replaced as a whole in case of a failure.

- CD Mechanism
- MAIN P.C.B.
- FRONT P.C.B.

下記のユニットは、小部品の部品供給はできません。  
故障の場合は、各ユニットを交換してください。

- CDメカニズム
- MAIN P.C.B.
- FRONT P.C.B.

## HOW TO MANUALLY EJECT THE TRAY / 手動でトレイを開く方法

- Turn the unit bottom up.
- Using a flatblade screwdriver, turn the loading cam 90 degrees in the direction indicated by an arrow in the figure.
- Gently pull the tray out.

- 本機を上下反転します。
- マイナスドライバーでローディングカムを図に示す矢印の方向に90度回転します。
- トレイをそっと引き出します。

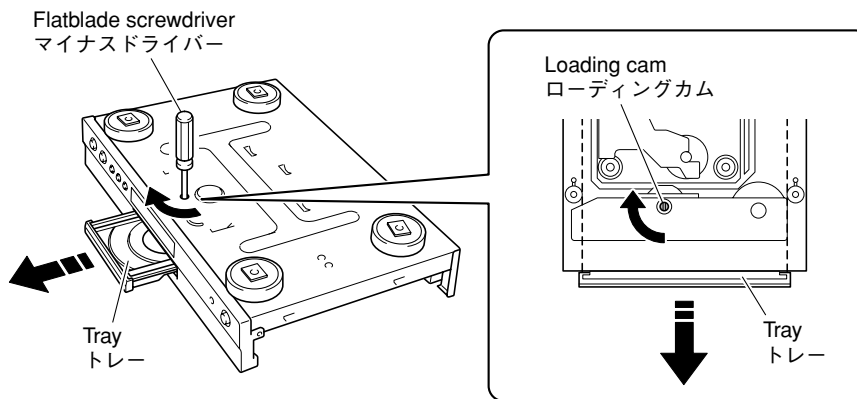

## DISASSEMBLY PROCEDURES

See REPLACEMENT PARTS LIST for item numbers.

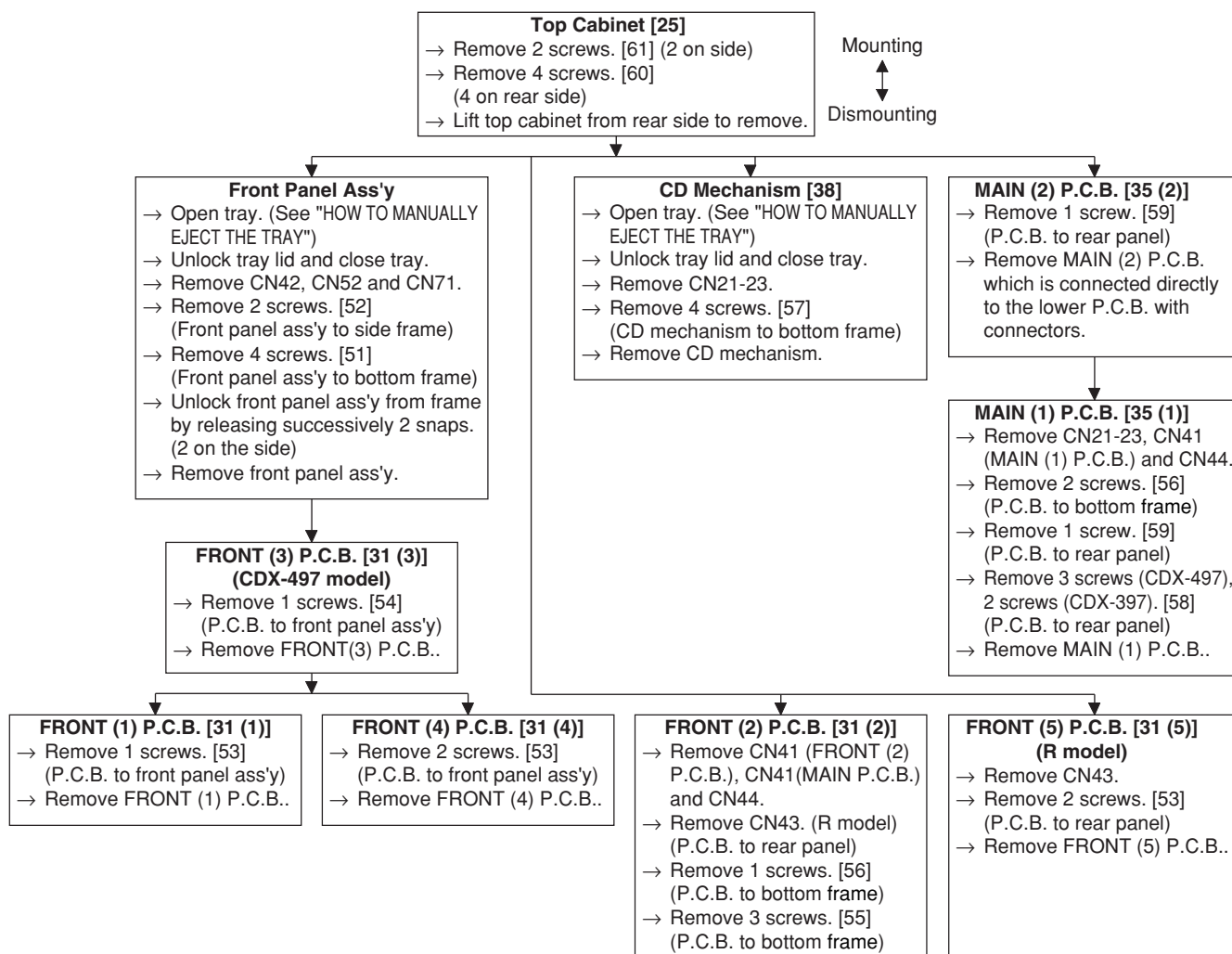

### Cable Connections

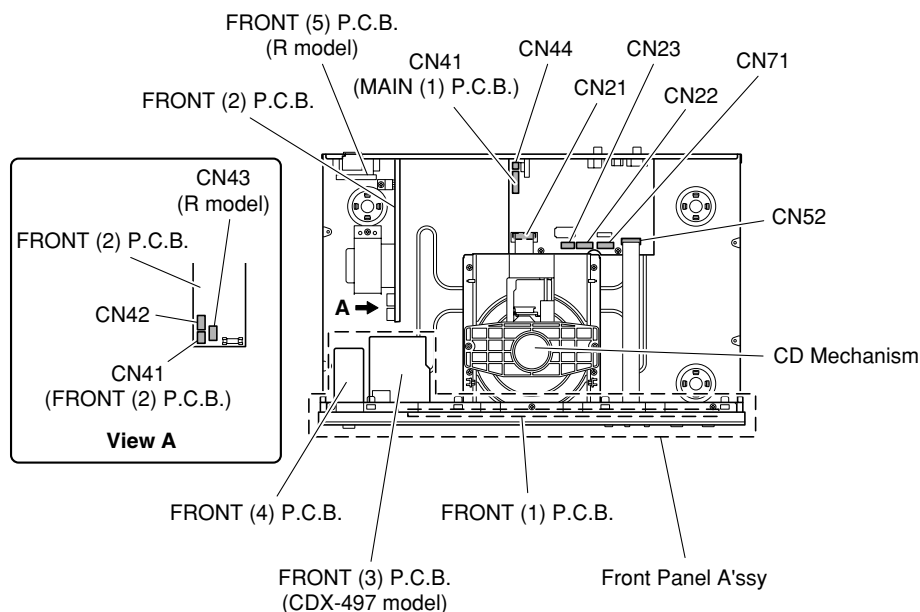

CDX-497/CDX-397

## ■ 分解手順

項目番号については、REPLACEMENT PARTS LISTを参照してください。

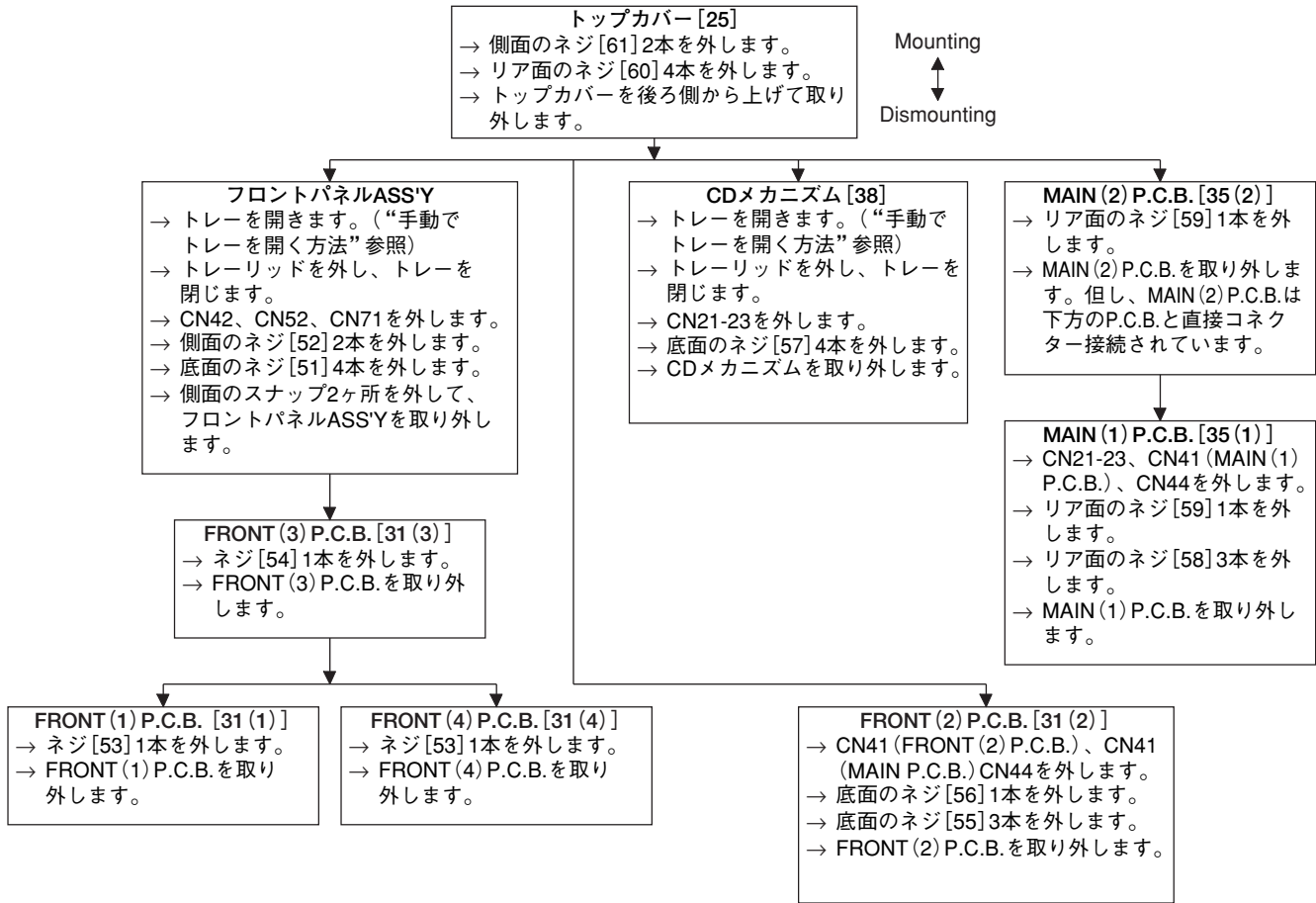

### ・コネクタ配置図

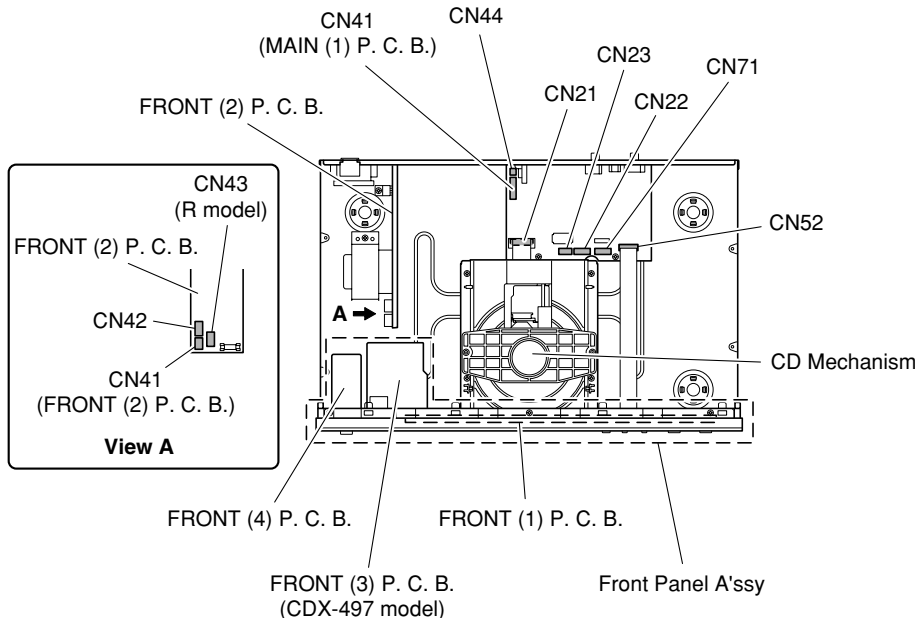

## ■ TEST MODE

### • Starting Test Mode

- Connect the power cable to the AC power outlet.
- Press the "POWER" key while simultaneously pressing "▶ / ■■" (PLAY/PAUSE) and "■" (STOP) keys of the main unit.
- When in the TEST mode, the "TEST MODE" is displayed for 2 seconds.

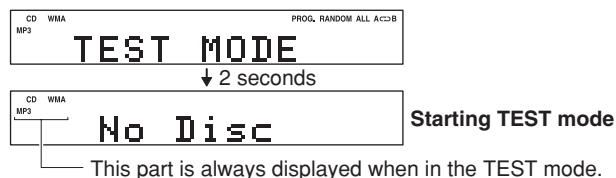

### 1. Function list of panel keys.

Panel key	Function
▲ (OPEN/CLOSE)	Tray open/close.
▶ / ■■ (PLAY/PAUSE)	Playback/Pause.
■ (STOP)	Stop.
◀◀ / ◀◀ (SKIP-/SEARCH-)	Move traverse reverse.
▶▶ / ▶▶ (SKIP+/SEARCH+)	Move traverse forward.

### 2. Function list of remote control keys.

Panel key	Function
▲ (OPEN/CLOSE)	Tray open/close.
▶ (PLAY)	Playback.
■■ (PAUSE)	Pause.
■ (STOP)	Stop.
◀◀ (SKIP-)	Move traverse reverse.
▶▶ (SKIP+)	Move traverse forward.
TIME/INFO	Check FL display. (*1)
SPACE	EEPROM write/read test.
RANDOM	Spindle servo on/off.
OUTPUT LEVEL +	Output level up. (CDX-497 model)
OUTPUT LEVEL -	Output level down. (CDX-497 model)

#### \*1 Check FL display

The display condition varies as shown below according to the "TIME/INFO" key of the remote control.

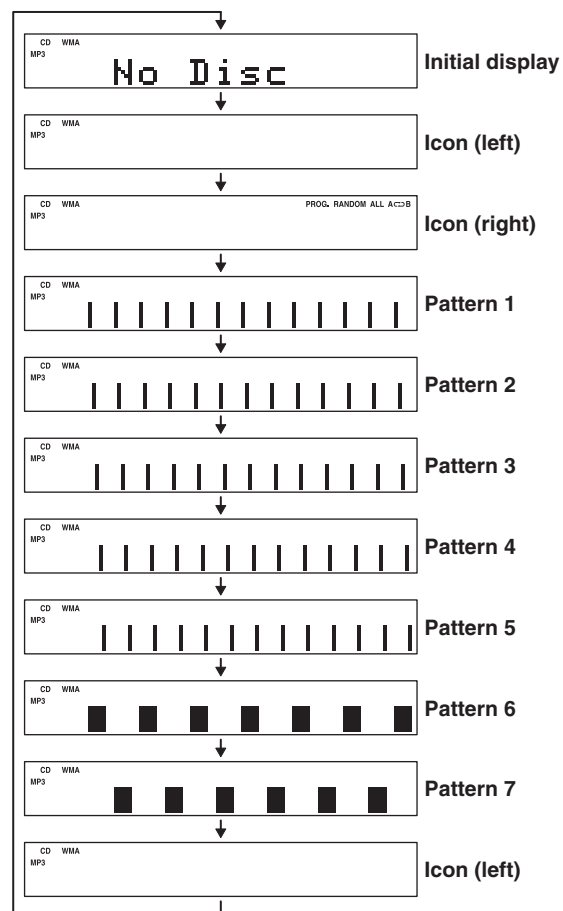

### • Canceling Test Mode

Press the "POWER" key of the main unit.

## ■ テストモード

### ・ テストモードの起動

- 電源コードをACコンセントに接続します。
- 同時に本機の“▶/■”(PLAY/PAUSE)キーと“■”(STOP)キーを押しながら、“POWER”キーを押します。
- テストモードが起動し、約2秒間“TEST MODE”が表示されます。



### 1. パネルキー操作

パネルキー	機能
▲ (OPEN/CLOSE)	トレイ オープン/クローズ
▶ / ■ (PLAY/PAUSE)	再生 (DISC挿入時) / 一時停止 (DISC再生時)
■ (STOP)	停止 (DISC再生時)
◀◀ / ◀ (SKIP-/SEARCH-)	トラバース内周移動
▶▶ / ▶ (SKIP+/SEARCH+)	トラバース外周移動

### 2. リモコンキー操作

パネルキー	機能
▲ (OPEN/CLOSE)	トレイ オープン・クローズ
▶ (PLAY)	再生 (DISC挿入時)
■ (PAUSE)	一時停止 (DISC再生時)
■ (STOP)	停止 (DISC再生時)
◀◀ (SKIP-)	トラバース内周移動
▶▶ (SKIP+)	トラバース外周移動
TIME/INFO	表示器チェック(*1)
SPACE	EEPROM書き込み / 読み取りテスト
RANDOM	スピンドルサーボオン/オフ
OUTPUT LEVEL +	出力レベルを上げる
OUTPUT LEVEL -	出力レベルを下げる

#### \*1 表示器チェック

リモコンの“TIME/INFO”キーを押すことにより、表示状態が下記のように変わります。

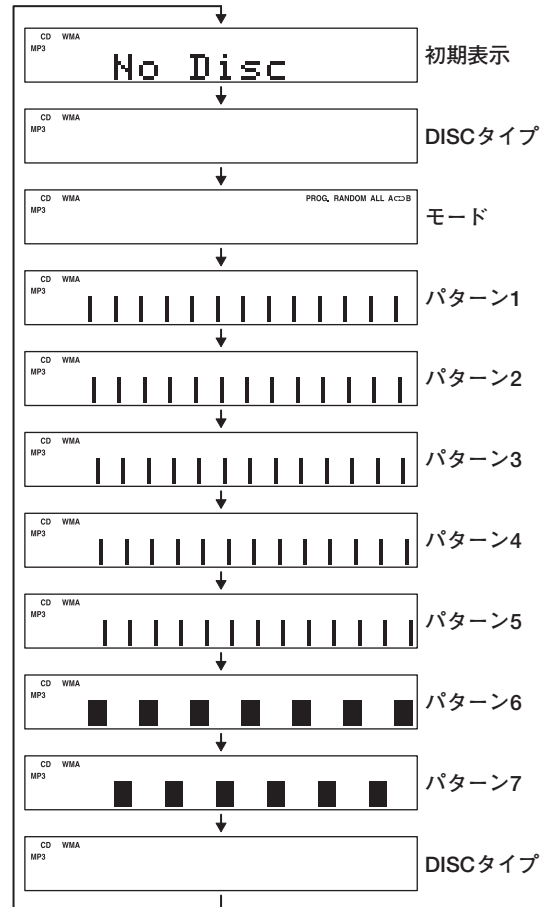

### ・ テストモードの解除

本機の“POWER”キーを押します。

■ IC DATA

IC21 : TC94A54 (MAIN P.C.B)  
DSP

\* No replacement part available.

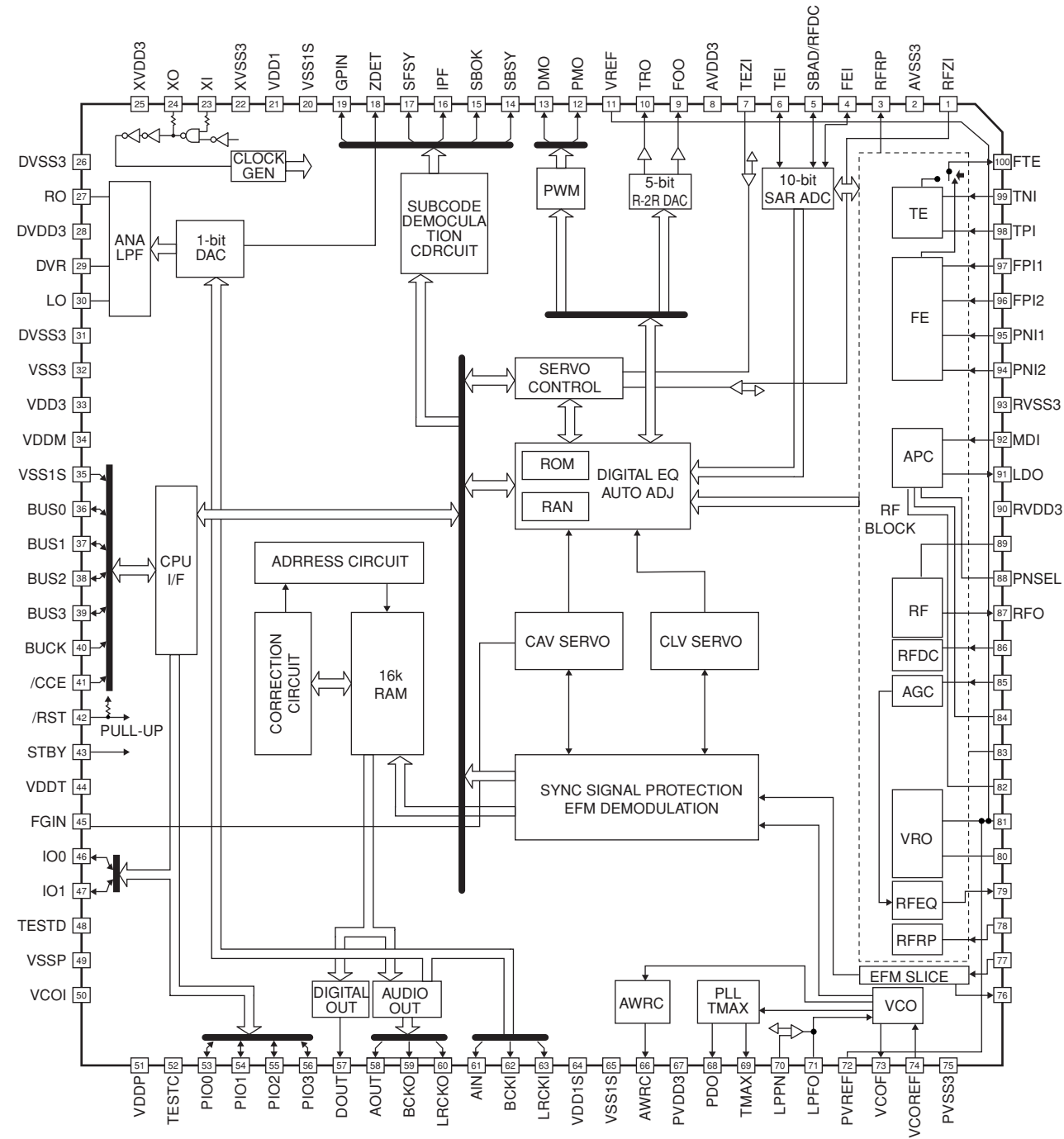

IC21 : TC94A54 (MAIN P.C.B)  
DSP

Pin No.	Pin name	I/O	Description	Remark
1	RFZI	I 3A/I/F	Input pin for the RF ripple zero-cross signal.	To be connected to the RFRP via 0.033 uF.
2	AVSS3	-	Grounding pin for 3.3V analog circuits.	-
3	RFRP	O 3A/I/F	RF ripple signal output pin.	-
4	FEI	O 3A/I/F	Focus error signal input pin.	Monitor pin for various signals.
5	SBAD/RFDC	O 3A/I/F	Subbeam addition signal input pin.	
6	TEI	O 3A/I/F	Tracking error signal input pin.	To be connected to the TEI via 0.033 uF.
7	TEZI	I 3A/I/F	Input pin for tracking error signal zero-cross.	
8	AVDD3	-	Supply voltage pin for 3.3V analog circuit.	-
9	FOO	O 3A/I/F	Forcus equalizer output pin.	-
10	TRO	O 3A/I/F	Tracking equalizer output pin.	-
11	VREF	O 3A/I/F	Analog reference supply voltage pin.	Connected to the VRO and PVREF within the IC. To be connected 0.1 uF.
12	FMO	O 3A/I/F	Speed error/feed equalizer output pin.	PWM ternary output (AVDD3, GND, and VREF).
13	DMO	O 3A/I/F	Disc equalizer output pin.	
14	SBSY (SPCK)	O 3I/F	Pin for outputting the subcode block sync signal. It is "H" at position S1 when the subcode sync signal is detected. (CD Processor Status Read Clock (176.4 kHz) output)	"H" at S1 when Subcode Sync is detected.
15	SBOK (FOK) (CLCK) (MBOV)	O 3I/F	Pin for outputting the CRCC check result of a subcode Q data check. It is "H" when the check result is OK. (Focus OK signal) (Input/output pin for the clock used in reading the subcode P to W data.) (CD Buffer memory overflow output)	-
16	IPF (SPDA)	O 3I/F	Correction flag output pin. "H" if the AOUT pin outputs an uncorrectable symbol in C2 correction. (CD Processor Status signal output)	-
17	SFSY (EMPH) (LOCK) (MONIT)	O 3I/F	Pin for outputting the playback frame sync signal. (Emphasis flag output pin. ENPH on: "H". EMPH off: "L". The output polarity can be switched, using a command.) (LOCK signal) (Pin for monitoring signals in the DSP.)	7.35kHz (At this pin, flags in the DSP and PLL-circuit clock can be monitored, using microcontroller commands. The pin also outputs text data serially.)
18	ZDET (DATA) (COFS)	O 3I/F	Output pin for zero detection flag for the 1-bit DAC. (Pin for outputting subcode P to W data) (Error Correstion Frame Clock 7.35 kHz output)	Valid also for 1-bit DAC external inputs.
19	GPIN	I/O 3I/F	General-purpose I/O (DSP)	General-purpose I/O (input after a reset).
20	VSS1	-	1.5V grounding pin dedicated to the Digital circuit.	-
21	VDD1	-	1.5V supply voltage pin dedicated to the Digital circuit.	-
22	XVSS3	-	Grounding pin for the system clock oscillation circuit.	-
23	XI	I 3A/I/F	Input pin for the system clock oscillation circuit.	-
24	XO	O 3A/I/F	Output pin for the system clock oscillation circuit.	Input to the internal MCK.
25	XVDD3	-	3.3V supply voltage pin for the system clock oscillation circuit.	-
26	DVSS3	-	Grounding pin for the 1-bit DAC.	-
27	RO	O 3A/I/F	Output pin for normal R-channel data for the 1-bit DAC.	No capacitor is required at the DVR pin unless the built-in 1-bit DAC is used.
28	DVDD3	-	3.3V supply voltage pin for the 1-bit DAC.	3.3V must be applied across the DVDD3 and DVSS3 pins, however.
29	DVR	O	Reference voltage pin for the 1-bit DAC.	-
30	LO	O 3A/I/F	Output pin for normal L-channel data for the 1-bit DAC.	-
31	DVSS3	-	Grounding pin for the 1-bit DAC.	-
32	VSS3	-	3.3V grounding pin dedicated to the I/F circuit	-
33	VDD3	-	3.3V supply voltage pin dedicated to the I/F circuit.	-



IC21 : TC94A54 (MAIN P.C.B)  
DSP

Pin No.	Pin name	Pin name	Function	Remark
34	VDDM	–	1.5V supply voltage pin dedicated to the DSP/1Mbit SRAM circuit.	–
35	VSS1	–	1.5V groundind pin dedicated to the DSP/1Mbit SRAM circuit.	–
36	BUS0	I/O 3I/F	Data input/output pin for the microcontroller interface.	To be fixed at "H" or "L" when communication is not in progress, so that the pin will not become HiZ.
37	BUS1	I/O 3I/F		
38	BUS2	I/O 3I/F		
39	BUS3	I/O 3I/F		
40	BUCK	I 3I/F	Clock input pin for the microcontroller interface.	To be fixed at "H" when communication is not in progress, so that the pin will not become HiZ.
41	/CCE	I 3I/F	Chip enable signal input pin for the microcontroller interface. BUS3 to BUS0 are active if this pin is "L".	
42	/RST	I 3I/F	Reset signal input pin. The internal registers and servo section registers are reset, respectively, when the reset signal is "L" and on the positive-going edge of the reset signal.	To be connected to 0.1 uF.
43	STBY	I 3I/F	STANDBY control pin dedicated to the DSP/1Mbit SRAM circuit.	–
44	VDDT	–	3.3V supply voltage pin dedicated to the Digital I/O circuit.	–
45	FGIN	I 3A/F	FG signal input pin for CAV. CLV: "L". CAV: FG input.	–
46	IO0A (/HSO)	I/O 3I/F	General-purpose input/output pins. (Pin for outputting the playback speed mode flag.)	General-purpose I/O (input after a reset). The playback speed mode flag output can be switched, using command bits.
47	IO1A (/UHSO)	I/O 3I/F		
48	TESTD	I 3I/F	DSP/Test input pin. Usually fixed at "L".	–
49	VSSP	–	1.5V grounding pin dedicated to the DSP/VCO circuit.	–
50	VCOI	O 1.5A/F	PD output pin dedicated to the DSP/VCO circuit.	–
51	VDDP	–	1.5V supply voltage pin dedicated to the DSP/VCO circuit.	–
52	TESTC	I 3I/F	CD/Test input pin. Usually fixed at "L".	–
53	PIO0	I/O 3I/F	General-purpose I/O (CD/DSP)	General-purpose I/O (input after a reset).
54	PIO1	I/O 3I/F	General-purpose I/O (CD/DSP)	
55	PIO2	I/O 3I/F	General-purpose I/O (DSP)	
56	PIO3	I/O 3I/F	General-purpose I/O (DSP)	
57	DOUT	O 3I/F	Digital-out output pin. Digital data for up to double speed can be output when a frequency of 16.9344 MHz is used.	As per CP-1201
58	AOUT	O 3I/F	Audio data output pin. Which bit is first (MSB first or LSB first) can be selected, using a command.	–
59	BCK	O 3I/F	Bit clock output pin. 32fs, 48fs, and 64fs can be selected, using a command.	Normal speed: 32fs = 1.4112 MHz
60	LRCK	O 3I/F	LR channel clock output pin. L for the L-channel and "H" for the R-channel. The output polarity can be inverted, using a command.	Normal speed: 44.1kHz
61	AIN	I 3I/F	1-bit DAC external input: AIN	1-bit DAC external input
62	BCKI	I 3I/F	1-bit DAC external input: BCKI	
63	LRCKI	I 3I/F	1-bit DAC external input: LRCKI	
64	VDD1	–	1.5V supply voltage pin dedicated to the DSP circuit.	
65	VSS1	–	1.5V grounding pin dedicated to the DSP circuit.	
66	AWRC	O 3A/F	VCO control pin for active wide range.	Controllable in CLV/CAV.
67	PVDD3	–	3.3V supply voltage pin dedicated to the PLL circuit.	–
68	PDO	O 3A/F	Pin for outputting a phase difference signal between the EFM signal and PLCK signal.	Quaternary output (PVDD3, HiZ, VSS, and PVREF).
69	TMAX	O 3A/F	Pin for outputting the result of TMAX detection. The TMAX pin output the same signal.	Ternary output (PVDD3, VSS, and HiZ).

IC21 : TC94A54 (MAIN P.C.B)  
DSP

Pin No.	Pin name	I/O	Description	Remark
70	LPFN	I 3A/F	Pin for receiving an inverted output of the PLL-circuit low-pass filter amp.	The resistance side is connected. See an applicable circuit diagram.
71	LPFO	O 3A/F	Pin for the PLL-circuit low-pass filter amp output.	The capacitor side is connected. See an applicable circuit diagram.
72	PVREF	–	1.65V reference supply voltage pin dedicated to the PLL circuit.	Connected to the VREF and PVREF within the IC. A 0.1 uF capacitor is connected.
73	VCOF	O 3A/F	VCO filter pin.	–
74	VCOREF	I 3A/F	Input pin for the VCO center frequency reference level.	To be connected to the PVREF if the AWRC is not used.
75	PVSS3	–	3.3V grounding pin dedicated to the PLL circuit.	–
76	SLCO	O 3A/F	EFM slice level output pin. For both analog and digital slice modes, the output impedance = 2.5 k-ohms.	A capacitor to be connected is selected according to the servo operation band.
77	RFI	I 3A/F	RF signal input pin. The input resistance can be selected, using a command.	Zin: 20 k-ohms, 10 k-ohms, 5 k-ohms
78	RFRPI	I 3A/F	RF ripple signal input pin.	–
79	RFEQO	O 3A/F	RF equalizer circuit output pin.	To be connected to the RFRPI via 0.1 uF and to the RFI via 4700 pF or higher.
80	RESIN	I 3A/F	Pin for connecting a reference current generating resistance.	To be connected to 22 k-ohms and 680 pF in parallel.
81	VRO	O 3A/F	1.65V reference voltage output pin.	Connected to the VREF and PVREF within the IC To be connected to 0.1uF anf 100 uF.
82	VMDIR	–	Reference voltage poutput pin for the APC circuit.	To be connected to 0.1uF.
83	TESTR	O 3A/F	LPF pin for RFEQO offset correction.	To be connected to 0.015 uF or higher.
84	INVSEL	I 3A/F	Test pin, usually fixed at "L".	–
85	AGCI	I 3A/F	Pin for RF signal amplitude adjustment amp input.	–
86	AGCI	I 3A/F	RF signal peak detction input pin.	–
87	RFO	O 3A/F	RF signal generation amp output pin.	To be connected directly to the RFDCl. To ne connected to the AGCI via 0.1 uF.
88	PNSEL	I 3A/F	Test pin, usually fixed at "H".	
89	EQSET	O 3A/F	External connection pin for the RF signal equalizer.	To be kept open when the RFEQ is used.
90	RVDD3	–	3.3V supply voltage pin for the Rfamp core section.	–
91	LDO	O 3A/F	Laser diode amp output pin.	
92	MDI	I 3A/F	Monitor photodiode amp input pin.	Reference to 178 mV (typ.)
93	RVSS3	–	3.3V grounding pin for the RF amp core section.	–
94	FNI2	I 3A/F	Main beam input pin. Connected to PIN diode C.	–
95	FNI1	I 3A/F	Main beam input pin. Connected to PIN diode A.	–
96	FPI2	I 3A/F	Main beam input pin. Connected to PIN diode D.	–
97	FPI1	I 3A/F	Main beam input pin. Connected to PIN diode B.	–
98	TPI	I 3A/F	Subbeam input pin. Connected to PIN diode F.	–
99	TNI	I 3A/F	Subbeam input pin. Connected to PIN diode E.	–
100	FTE	O 3A/F	Focus /tracking signal output. (Test pin for servo characteristic measurement.)	Switchable using a command.

Note: "3A/F : 3V circuit analog input/output pin."  
"3I/F : 3V circuit digital input/output pin."  
"1.5A/F : 1.5V circuit analog input/output pin."



**IC22** : TA2125 (MAIN P.C.B)

Motor driver

\* No replacement part available.

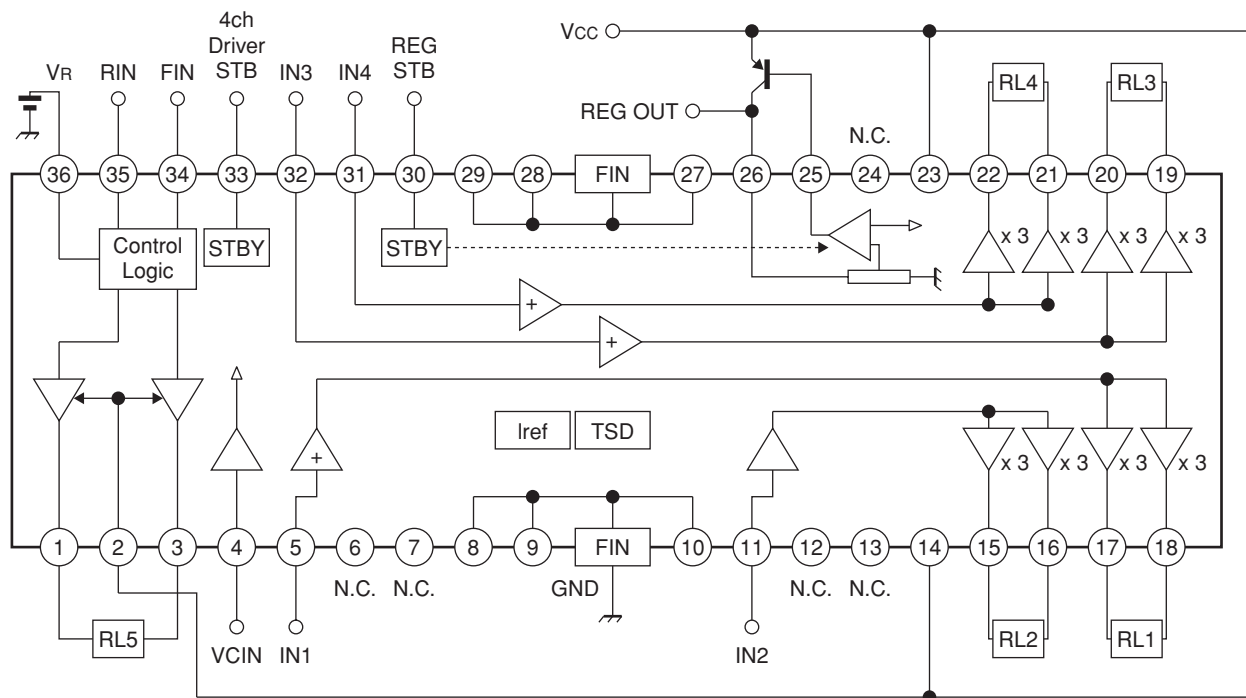

No.	Symbol	Function	
1	OUT5A	Output terminal	H-bridge
2	VM	Supply voltage terminal for Logic	H-bridge
3	OUT5B	Output terminal	H-bridge
4	VCIN	Input reference voltage	4ch BTL
5	IN1	Input for ch1	4ch BTL
6	N.C.	Open	-
7	N.C.	Open	-
8	N.C.	8, 9, 10, 27, 28, 29 are connected to PW GND (FIN)	-
9	N.C.	8, 9, 10, 27, 28, 29 are connected to PW GND (FIN)	-
10	N.C.	8, 9, 10, 27, 28, 29 are connected to PW GND (FIN)	-
11	IN2	Input for ch2	4ch BTL
12	N.C.	Open	-
13	N.C.	Open	-
14	VCC1	Supply voltage terminal for ch 1/ch2	4ch BTL
15	OUT2M	Inverted output for ch2	4ch BTL
16	OUT2P	Non-inverted output for ch2	4ch BTL
17	OUT1M	Inverted output for ch1	4ch BTL
18	OUT1P	Non-inverted output for ch1	4ch BTL
19	OUT3P	Non-inverted output for ch3	4ch BTL
20	OUT3M	Inverted output for ch3	4ch BTL
21	OUT4P	Non-inverted output for ch4	4ch BTL
22	OUT4M	Inverted output for ch4	4ch BTL
23	VCC2	Supply voltage terminal for ch3/ch4	4ch BTL
24	N.C.	Open	-
25	REG OUT	Connection with BASE of PNP Tr	Regulator
26	REG OUT	Output for regulator (5V)	Regulator
27	N.C.	8, 9, 10, 27, 28, 29 are connected to PW GND (FIN)	-
28	N.C.	8, 9, 10, 27, 28, 29 are connected to PW GND (FIN)	-
29	N.C.	8, 9, 10, 27, 28, 29 are connected to PW GND (FIN)	-
30	REG STBY	Standby control for regulator	Regulator
31	IN4	Input for ch4	4ch BTL
32	IN3	Input for ch3	4ch BTL
33	STBY	Standby control for 4ch BTL	4ch BTL
34	FIN	Logic control input	H-bridge
35	RIN	Logic control input	H-bridge
36	VR	Supply voltage terminal for motor driver	H-bridge

IC71 : CS4392 (MAIN P.C.B)  
DAC

\* No replacement part available.

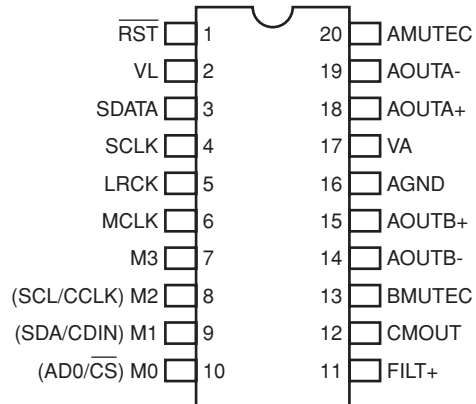
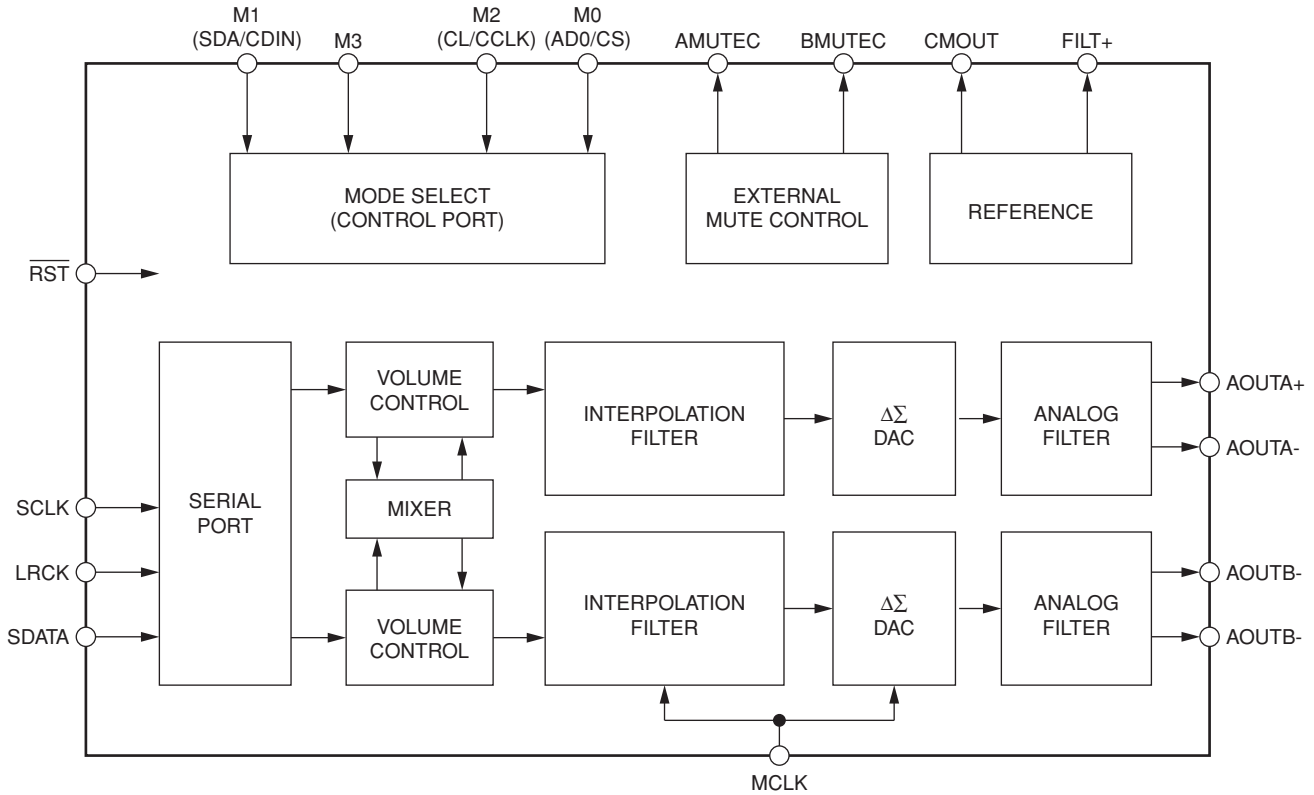

CDX-497/CDX-397

IC71 : CS4392 (MAIN P.C.B)  
DAC

No.	Symbol	Function
1	RST	Reset (Input) - Powers down device and resets all internal registers to their default settings.
2	VL	Logic Power (Input) - Positive power for the digital input/output.
3	SDATA	Serial Audio Data (Input) - Input for two's complement serial audio data.
4	SCLK	Serial Clock (input/output) - Serial clock for the serial audio interface.
5	LRCK	Left Right Clock (Input/output) - Determines which channel, Left or Right, is currently active on the serial audio data line.
6	MCLK	Master Clock (Input) -Clock source for the delta-sigma modulator and digital filters.
11	FILT+	Positive Voltage Reference (Output) - Positive reference voltage for the internal sampling circuits.
12	CMOUT	Common Mode Voltage (Output) - Filter connection for internal quiescent voltage.
20	AMUTE $\overline{C}$	Mute Control (output) - The Mute Control pin goes high during power-up initialization, reset, muting, power-down or if the master clock to left/right clock frequency ratio is incorrect.
13	BMUTE $\overline{C}$	
14	AOUTB-	
15	AOUTB+	Differential Analog Output (Outputs) - The full scale differential analog output level is specified in the Analog Characteristics specification table.
18	AOUTA+	
19	AOUTA-	
16	AGND	Ground (Input)
17	VA	Analog Power (Input) - Positive power for the analog section.

#### Control Port mode Definitions

No.	Symbol	Function
7	M3	Mode Selection (Input) -This pins should be tied to GND level during control port mode.
8	SCL/CCLK	Serial Control Port Clock (input) - Serial clock for the serial control port.
9	SDA/CDIN	Serial Control Data (input/output) - SDA is a data I/O line in I <sup>2</sup> C mode.CDIN is the input data line for the control port interface in SPI mode.
10	AD0/ $\overline{CS}$	Address Bit 0 (I <sup>2</sup> C) / Control Port Chip Select (SPI) (Input/Output) - AD0 is a chip address pin in I <sup>2</sup> C mode, $\overline{CS}$ is the chip select signal for SPI format.

#### Stand-Alone Mode Definitions

No.	Symbol	Function
7	M3	
8	M2	
9	M1	
10	M0	Mode Selection (Input) - Determines the operational mode of the device.

# ■ BLOCK DIAGRAM

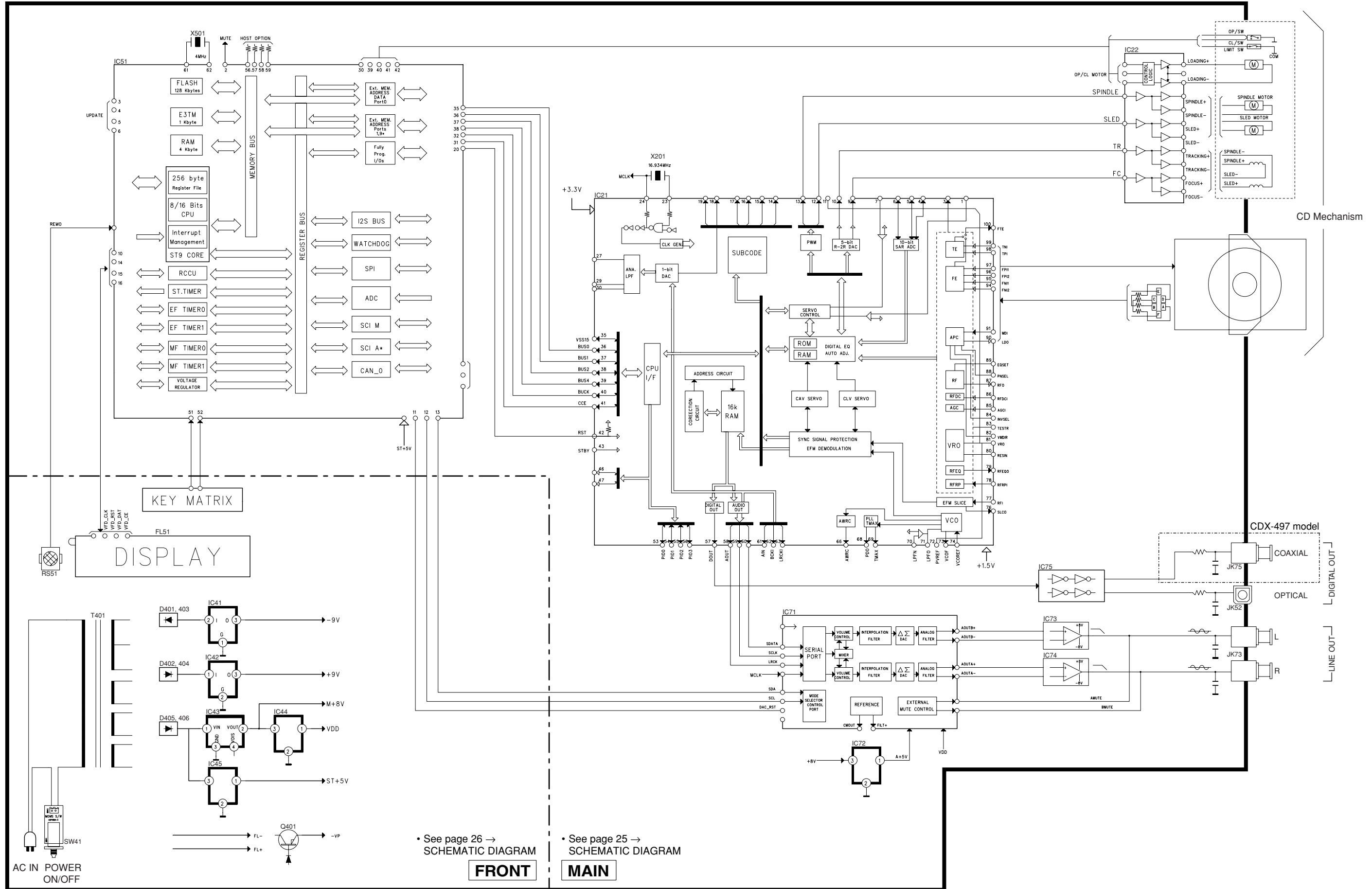

• See page 26 → SCHEMATIC DIAGRAM

**FRONT**

• See page 25 → SCHEMATIC DIAGRAM

**MAIN**

1 ■ WIRING DIAGRAM

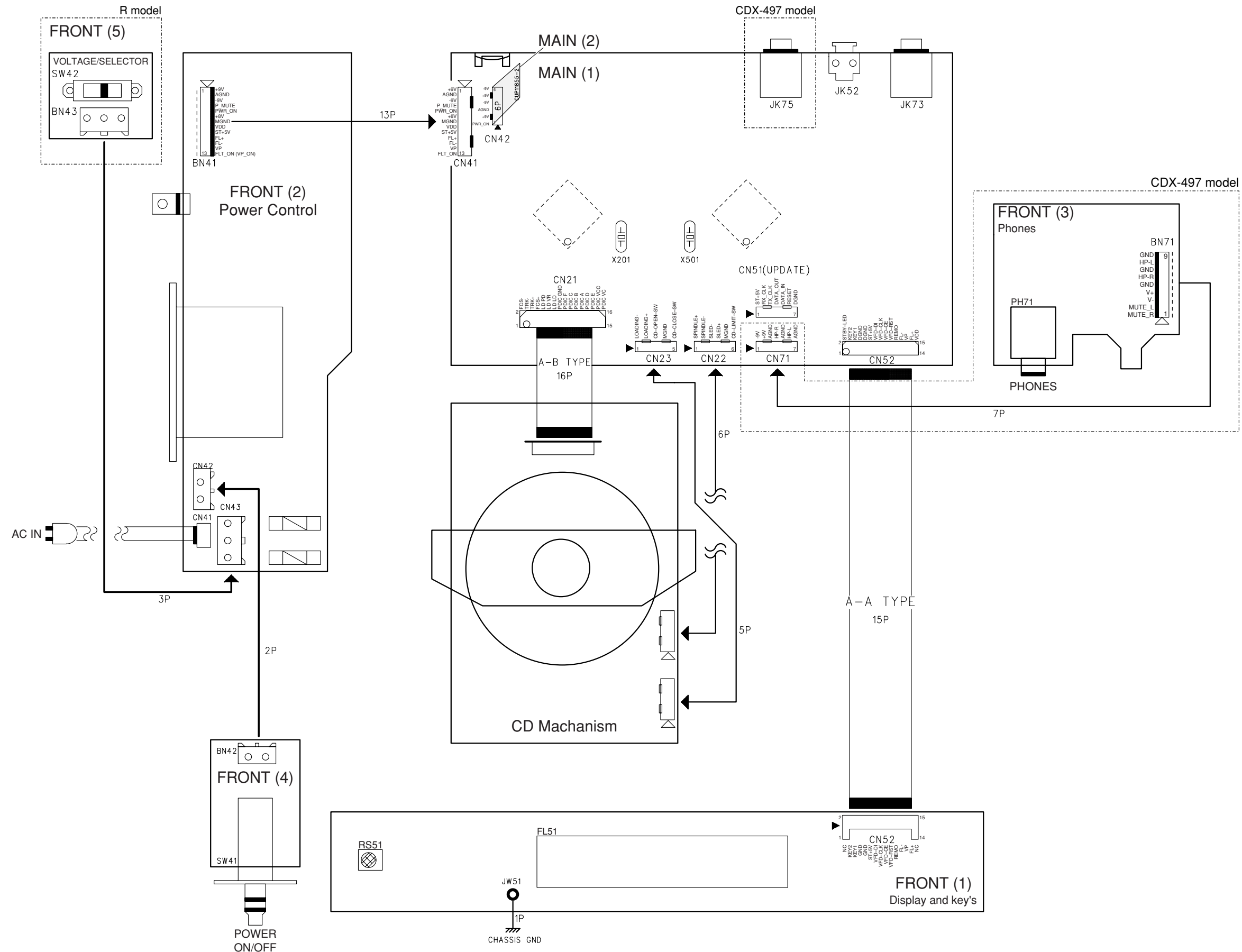

### PRINTED CIRCUIT BOARDS

FOR INFORMATION ONLY (NO SERVICE PARTS WILL BE AVAILABLE)

**MAIN (1) P.C.B.** (Top view)

**MAIN (2) P.C.B.** (Top view)

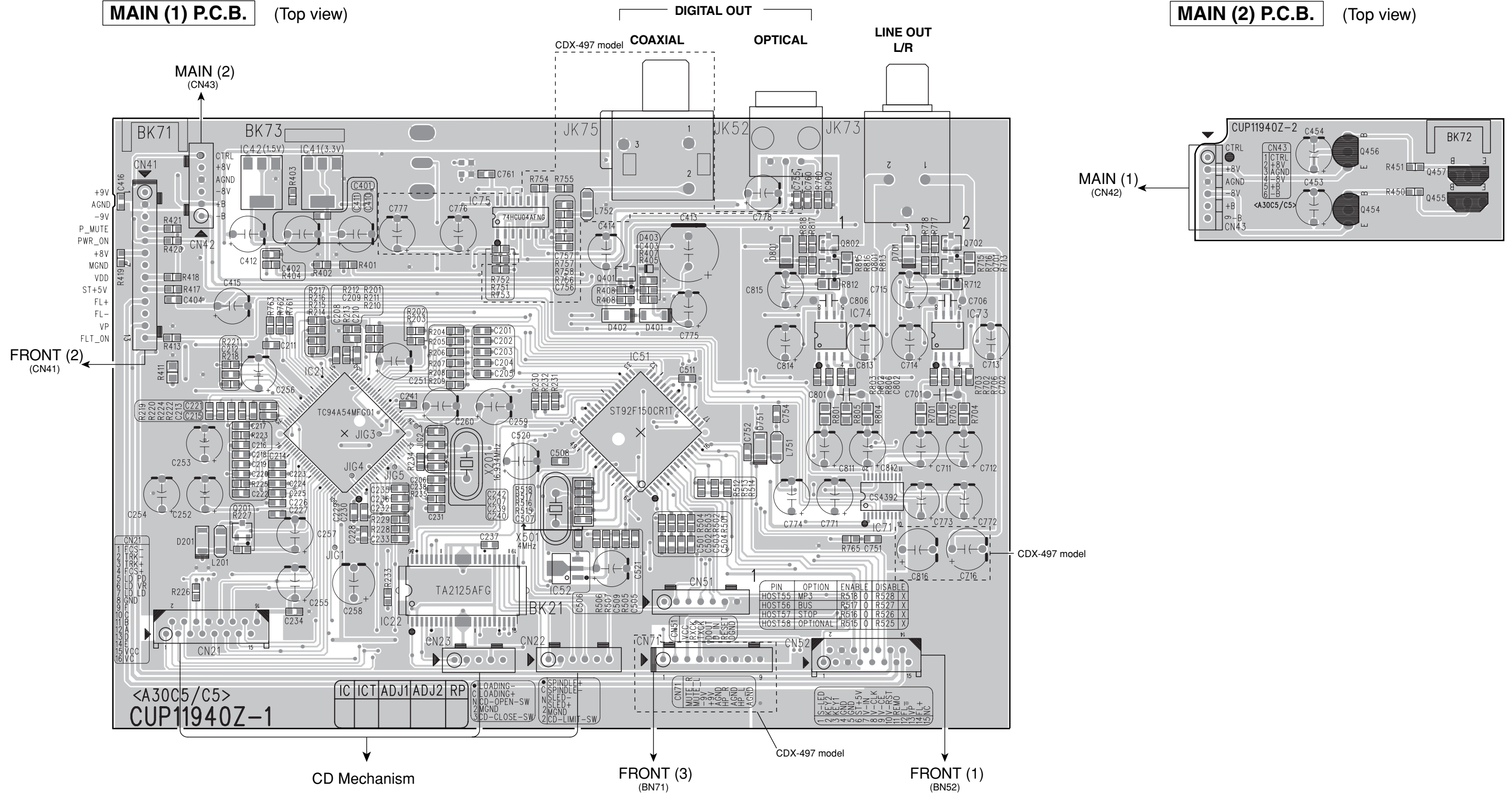

**MAIN (1) P.C.B.** (Bottom view)

**MAIN (2) P.C.B.** (Bottom view)

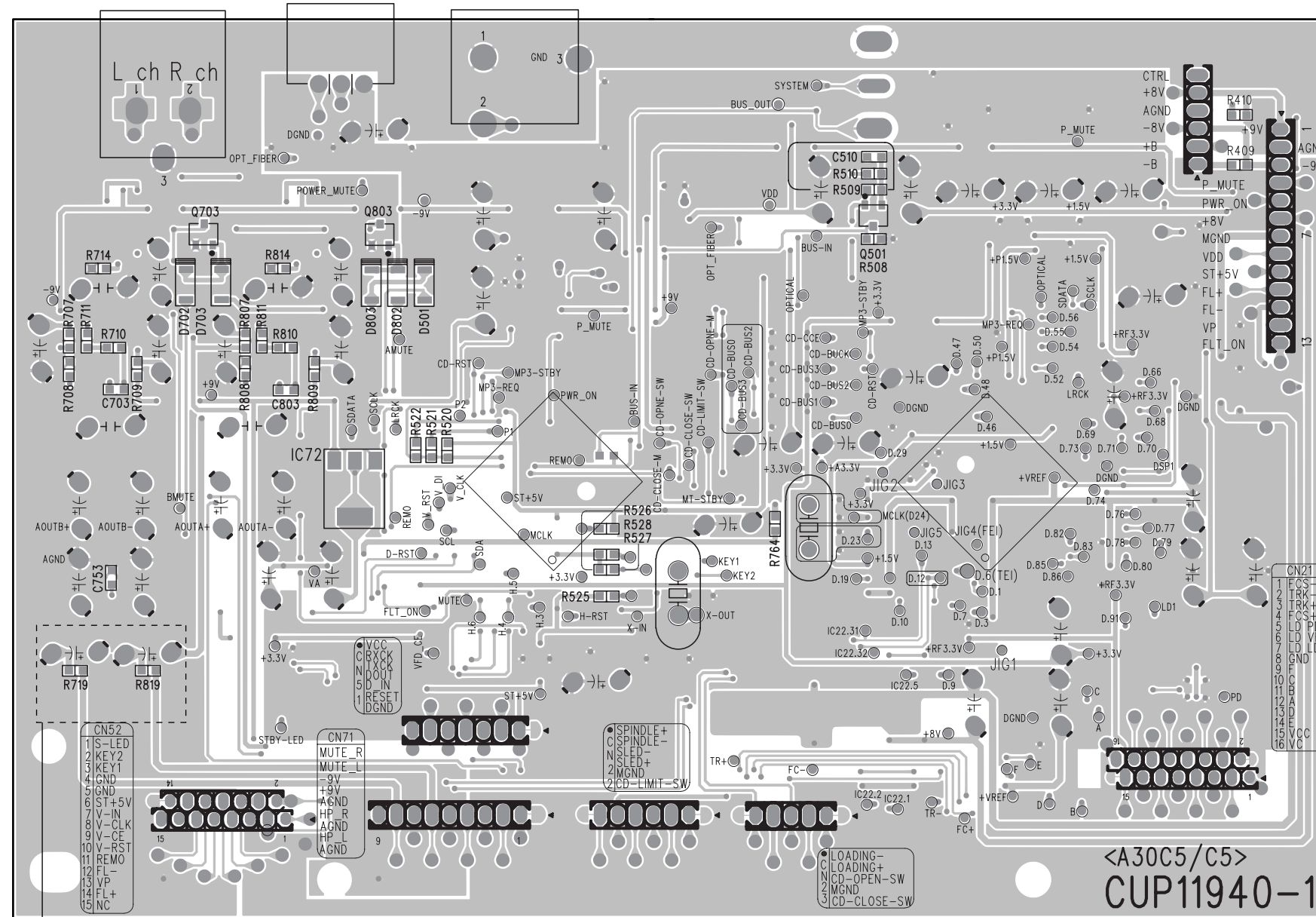

CDX-497 model

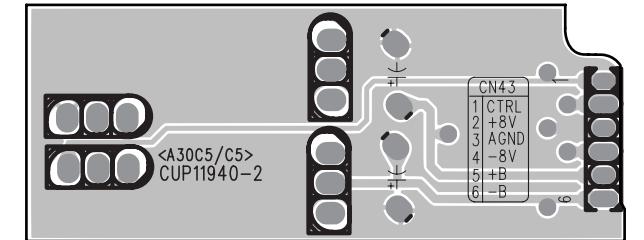



1 ■ SCHEMATIC DIAGRAMS

FOR INFORMATION ONLY (NO SERVICE PARTS WILL BE AVAILABLE)

MAIN

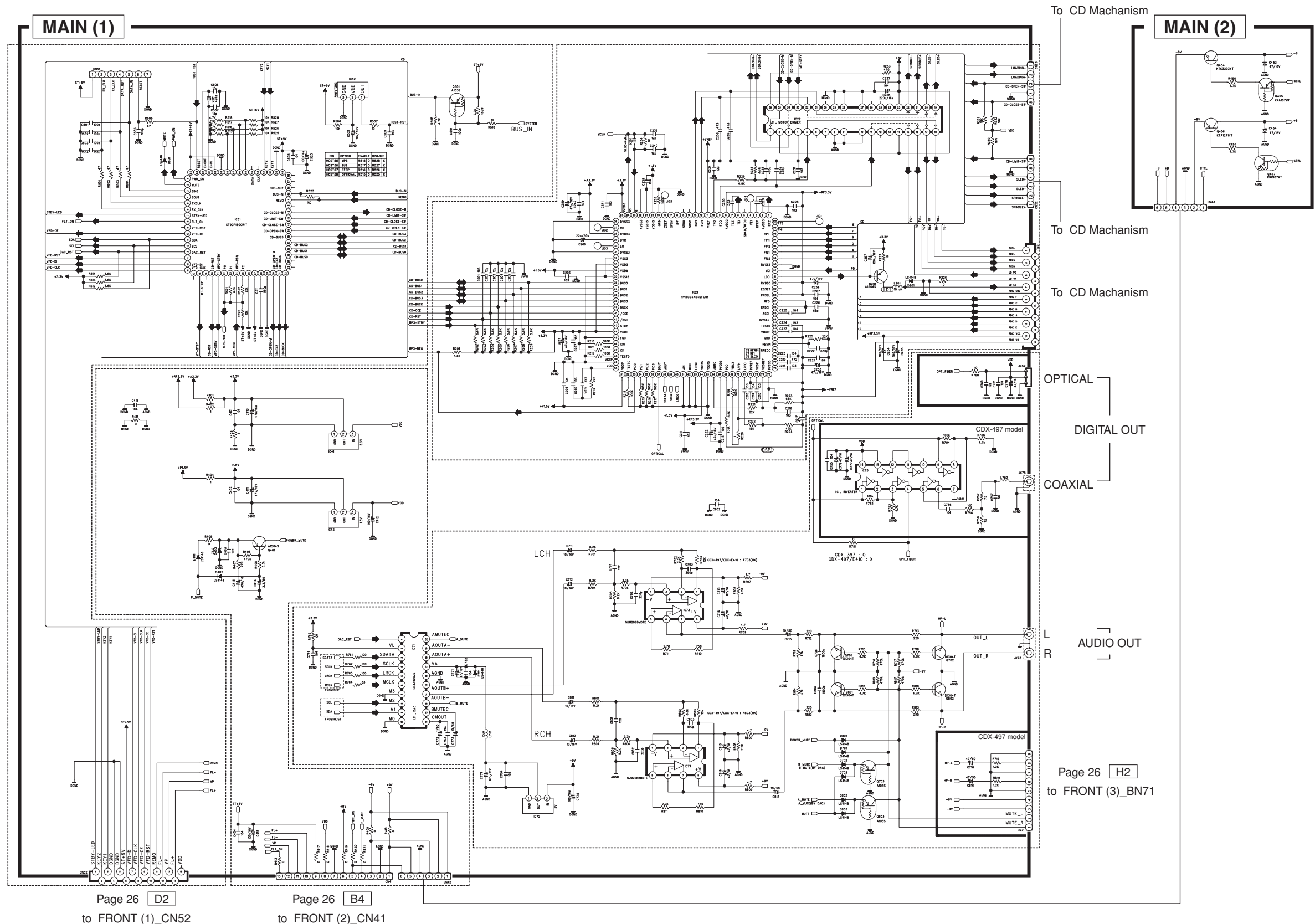

Page 26 D2 to FRONT (1)\_CN52

Page 26 B4 to FRONT (2)\_CN41

Page 26 H2 to FRONT (3)\_BN71

★ Components having special characteristics are marked  $\triangle$  and must be replaced with parts having specifications equal to those originally installed.  
 ★ Schematic diagram is subject to change without notice.

●  $\triangle$ 印のある部品は、安全性確保部品を示しています。部品の交換が必要な場合、パーツリストに記載されている部品を使用してください。  
 ● 本回路図は標準回路図です。改良のため予告なく変更することがございます。



FRONT

Page 25 B7  
to MAIN (1)\_CN52

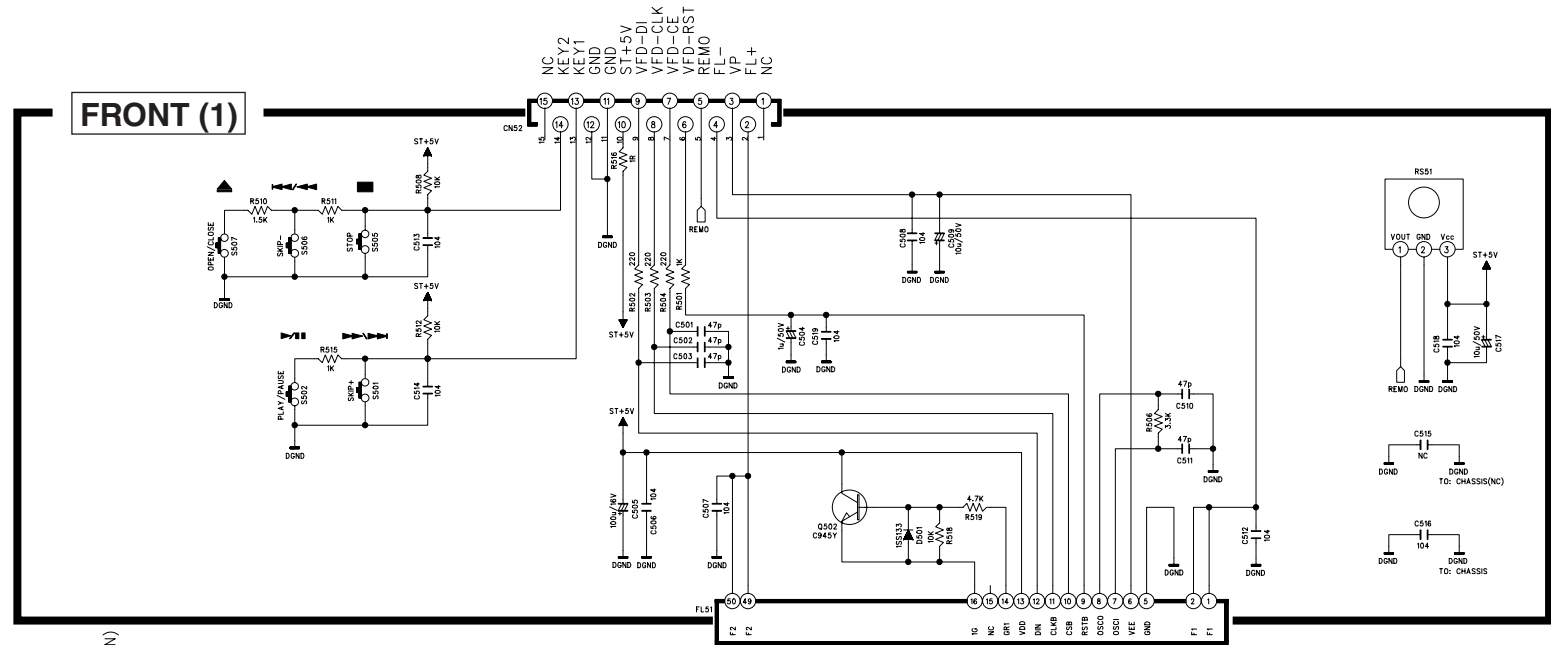

Page 25 C7  
to MAIN (1)\_CB41

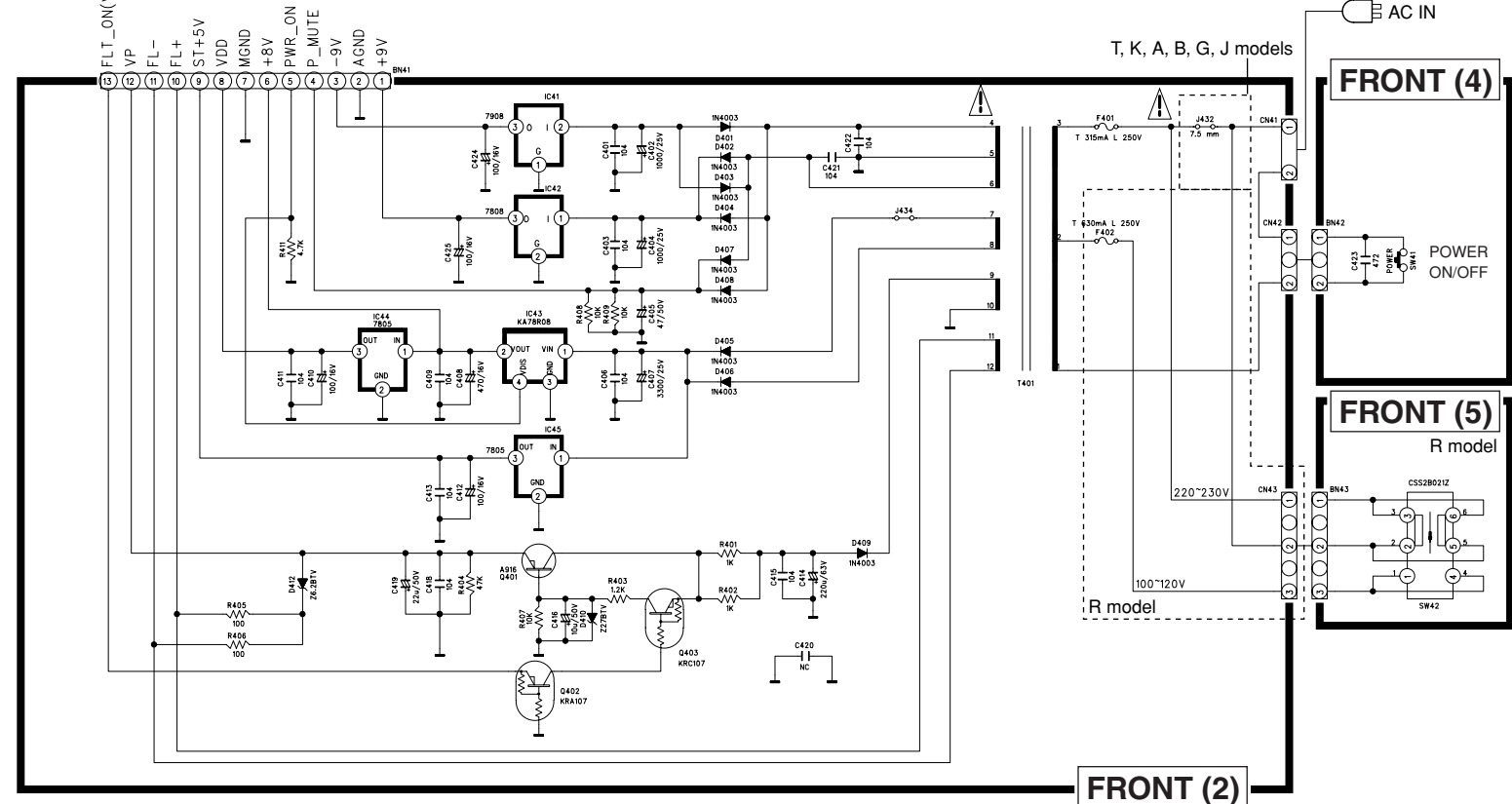

FRONT (2)

Page 25 H6  
to MAIN (1)\_CN71

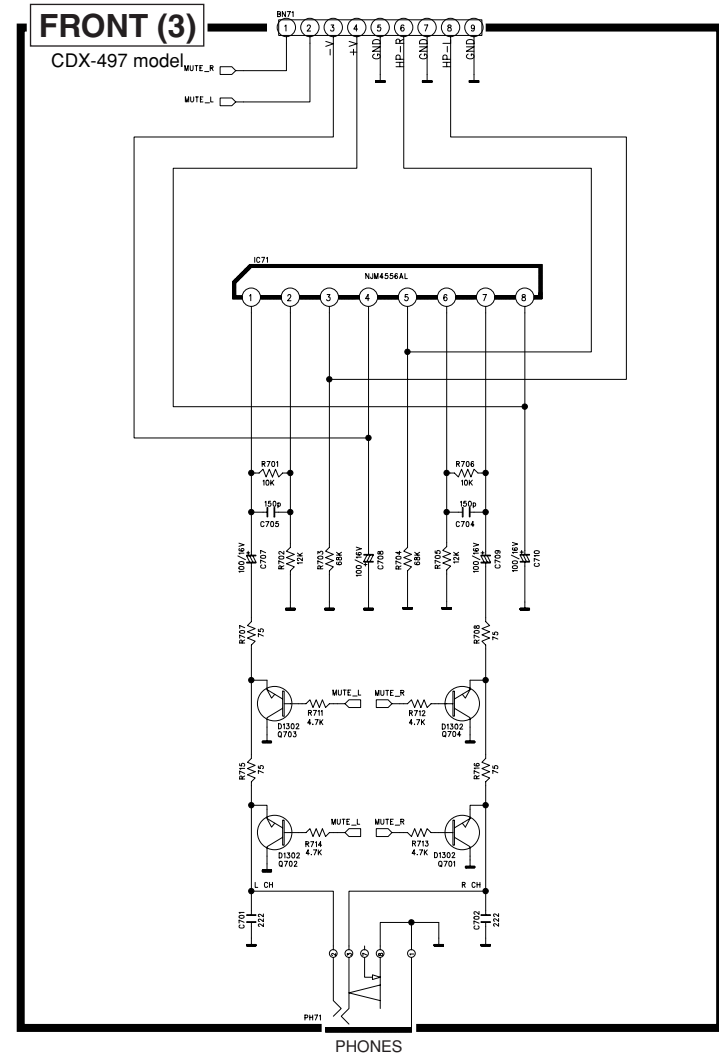

220-240 VOLTS  
110-120 VOLTS

VOLTAGE  
SELECTOR

★ Components having special characteristics are marked  $\Delta$  and must be replaced with parts having specifications equal to those originally installed.  
★ Schematic diagram is subject to change without notice.



●  $\Delta$ 印のある部品は、安全性確保部品を示しています。部品の交換が必要な場合、パーツリストに記載されている部品を使用してください。  
● 本回路図は標準回路図です。改良のため予告なく変更することがございます。

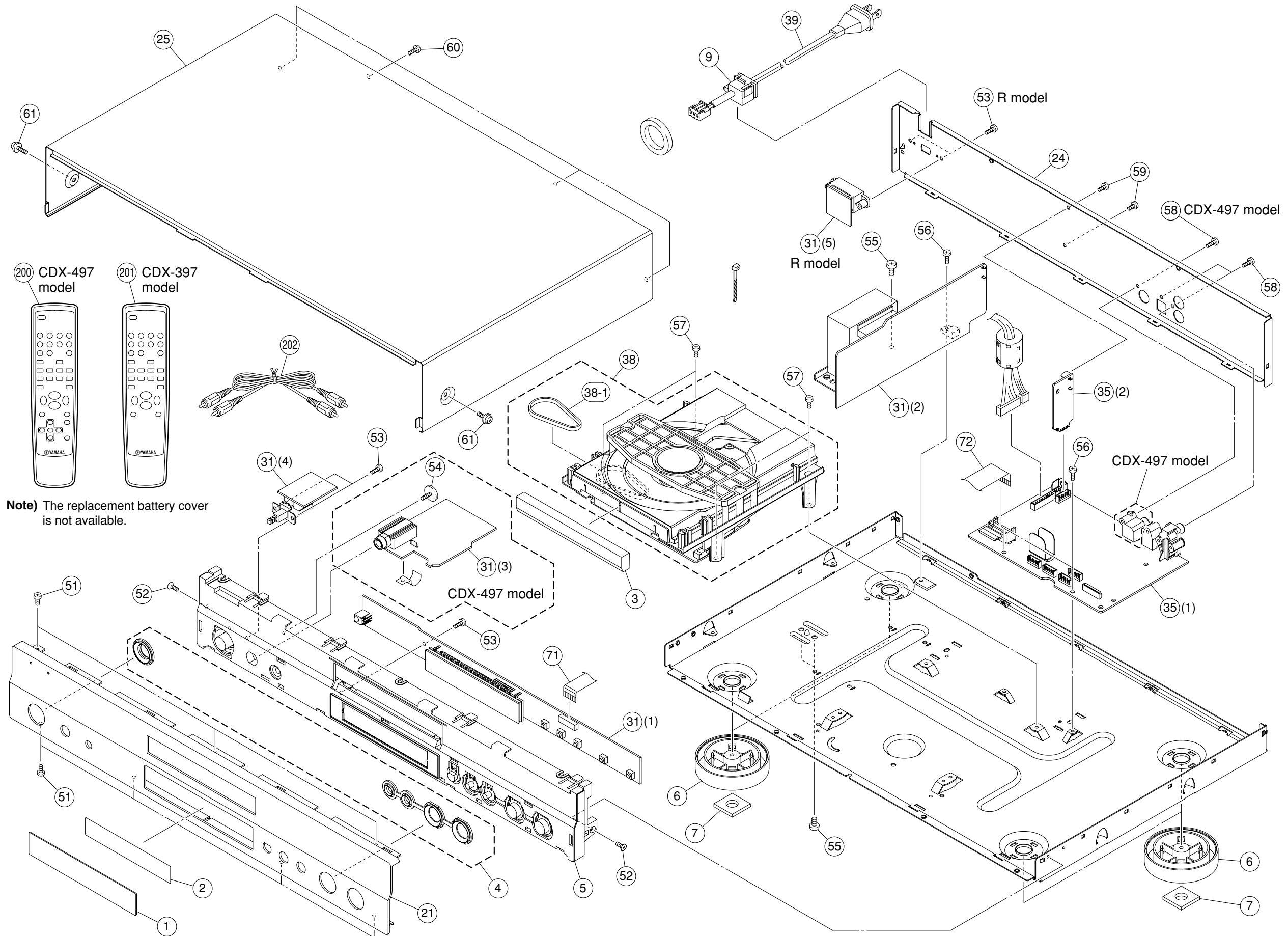









REPLACEMENT PARTS LIST



**Note)** The replacement battery cover is not available.

**WARNING**

- Components having special characteristics are marked  and must be replaced with parts having specifications equal to those originally installed.
- 印のある部分は、安全確保部品を示しています。部品の交換が必要な場合、パーツリストに記載されている部品を使用してください。
- 部品価格ランクは、予告なく変更することがあります。

Ref. No.	Part No.	Description	Remarks	Markets	部 品 名	Rank			
*	1	AAx78150	FL WINDOW		CGU1A393Z	FL ウィンドウ			
*	2	AAx78160	FL SHEET		CMZ1A117Z	FL シート			
*	3	AAx78350	TRAY LID (DOOR ORNAMENT)	GD	CGR1A400M9XH54	トレイ L I D			
*	3	AAx78360	TRAY LID (DOOR ORNAMENT)	BL	CGR1A400ZH53	トレイ L I D			
*	3	AAx78340	TRAY LID (DOOR ORNAMENT)	TI	CGR1A400M7YH55	トレイ L I D			
*	4	AAx78270	ESCUTCHEON (BUSHING)	GD	CGR1A399M9D6	エスカッション			
*	4	AAx78250	ESCUTCHEON (BUSHING)	BL	CGR1A399K128	エスカッション			
*	4	AAx78260	ESCUTCHEON (BUSHING)	TI	CGR1A399M7G41	エスカッション			
*	5	AAx78300	SUB PANEL	GD	CGW1A422M9D6	サブパネル			
*	5	AAx78280	SUB PANEL	BL	CGW1A422K128	サブパネル			
*	5	AAx78290	SUB PANEL	TI	CGW1A422M7G41	サブパネル			
*	6	AAx78660	FOOT	GD	CKL1A192H57	脚			
*	6	AAx78650	FOOT	BL, TI	CKL1A192H56	脚			
*	7	AAx76760	CUSHION FOOT		CHG1A329	クッション 脚			
*	9	AAx73380	CABLE STOPPER		KHR1A028	コードストッパー	01		
*	21	AAx78470	FRONT PANEL	497GD	CKM2A176ZC55	フロントパネル			
*	21	AAx78480	FRONT PANEL	497BL	CKM2A176ZC59	フロントパネル			
*	21	AAx78490	FRONT PANEL	497TI	CKM2A176ZC60	フロントパネル			
*	21	AAx78440	FRONT PANEL	397GD	CKM1A176ZC55	フロントパネル			
*	21	AAx78450	FRONT PANEL	397BL	CKM1A176ZC59	フロントパネル			
*	21	AAx78460	FRONT PANEL	397TI	CKM1A176ZC60	フロントパネル			
*	24	AAx78590	REAR PANEL	497	CKF3A312T	リアパネル			
*	24	AAx78620	REAR PANEL	497	CKF4A312S	リアパネル			
*	24	AAx78580	REAR PANEL	497	CKF3A312R	リアパネル			
*	24	AAx78570	REAR PANEL	497	CKF3A312Q	リアパネル			
*	24	AAx78600	REAR PANEL	497	CKF3A312U	リアパネル			
*	24	AAx78610	REAR PANEL	497	CKF3A312V	リアパネル			
*	24	AAx78560	REAR PANEL	397	CKF2A312X	リアパネル			
*	24	AAx78530	REAR PANEL	397	CKF1A312W	リアパネル			
*	24	AAx78540	REAR PANEL	397	CKF1A312Y	リアパネル			
*	24	AAx78550	REAR PANEL	397	CKF1A312Z	リアパネル			
*	25	AAx80040	TOP CABINET	GD	CKC1A173D8	トップカバー			
*	25	AAx78320	TOP CABINET	BL	CKC1A173B11	トップカバー			
*	25	AAx78330	TOP CABINET	TI	CKC1A173G40	トップカバー			
*		31	AAx78170	P. C. B. ASS' Y	497 FRONT	COP11891B	JTKABG	P C B フロント	
*		31	AAx78180	P. C. B. ASS' Y	497 FRONT	COP11891D	R	P C B フロント	
*		31	AAx78190	P. C. B. ASS' Y	397 FRONT	COP11891F	R	P C B フロント	
*		31	AAx78200	P. C. B. ASS' Y	397 FRONT	COP11891E	TABG	P C B フロント	
*	35	AAx78210	P. C. B. ASS' Y	497 MAIN	COP11855B	P C B メイン			
*	35	AAx78220	P. C. B. ASS' Y	397 MAIN	COP11855C	P C B メイン			
*	38	AAx78140	CD MECHANISM		CJDKSL2130CCMZ	C D メカニズム			
*	38-1	AAx78500	BELT		9A07980900	ベルト			
*		39	AAx74330	POWER CABLE	2m	CJA2J049ZA	J	電源コード	04
*		39	AAx74340	POWER CABLE	2m	CJA2L072ZA	R	電源コード	
*		39	AAx74350	POWER CABLE	2m	CJA2N047ZA	T	電源コード	
*		39	AAx78680	POWER CABLE	2m	CJA2D073Y	K	電源コード	
*		39	AAx74360	POWER CABLE	2m	CJA2S048ZA	A	電源コード	
*		39	AAx78690	POWER CABLE	2m	CJA2E086ZA	B	電源コード	
*		39	AAx74310	POWER CABLE	2m	CJA2B043ZA	G	電源コード	
*	51	AAx78510	BIND HEAD BONDING SCREW	GD, TI 3x6 MFZN2W3	CTBD3+6FFC	ボンディング小ネジ			
*	51	AAx78520	BIND HEAD BONDING SCREW	BL 3x6 MFZN2B3	CTBD3+6FFZR	ボンディング小ネジ			
*	52	AAx78670	FLAT HEAD B-TIGHT SCREW	3x6 MFZN2Y	CTS3+6JR	皿B タイトネジ			
*	53	AAx78410	BIND HEAD P-TIGHT SCREW	3x10 MFZN2Y	CTB3+10GR	バインドP タイトネジ			
*	54	AAx78240	PW HEAD P-TIGHT SCREW	3x10 MFZN2Y	CTWS3+10GR	PWヘッドP タイトネジ			
*	55	AAx78430	BIND HEAD SCREW	4x6 MFZN2Y	CTB4+6FR	バインド小ネジ			
*	56	AAx78390	BIND HEAD B-TIGHT SCREW	3x8 MFZN2Y	CTB3+8JR	バインドB タイトネジ			
*	57	AAx78420	BIND HEAD SCREW	3x6 MFZN2Y	CTB3+6FR	バインド小ネジ			
*	58	AAx78400	BIND HEAD P-TIGHT SCREW	3x10 MFZN2B3	CTB3+10GFZR	バインドP タイトネジ			
*	59	AAx78370	BIND HEAD B-TIGHT SCREW	3x6 MFZN2B3	CTB3+6JFZR	バインドB タイトネジ			

\* New Parts \* 新規部品

Ref. No.	Part No.	Description	Remarks	Markets	部 品 名	Rank	
*	60	AAx73500	BIND HEAD B-TIGHT SCREW	GD, TI 3x8 MFZN2W3	CTB3+8JFC	バインドB タイトネジ	01
*	60	AAx78380	BIND HEAD B-TIGHT SCREW	BL 3x8 MFZN2B3	CTB3+8JFZR	バインドB タイトネジ	
*	61	AAx73930	PW HEAD B-TIGHT SCREW	GD, TI 3x8 MFZN2W3	CTW3+8JFC	PWヘッドB タイトネジ	01
*	61	AAx78230	PW HEAD B-TIGHT SCREW	BL 3x8 MFZN2B3	CTW3+8JFZR	PWヘッドB タイトネジ	
*	71	AAx79920	FLEXIBLE FLAT CABLE	15P 220mm P=1mm	CWC4F4A15A220A	カード電線	
*	72	AAx79910	FLEXIBLE FLAT CABLE	16P 140mm P=1mm	CWC4F2A16A140B	カード電線	
*	200	AAx78640	ACCESSORY REMOTE CONTROL	497	CARTCDX497	付属品 リモコン	
*	201	AAx78630	REMOTE CONTROL	397	CARTCDX397	リモコン	
*	202	AAx78310	AUDIO PIN CABLE BATTERY	2P 1.5m 1pc R03 2pcs	CJS4N001Y	ステレオピンケーブル 単4乾電池	

\* New Parts \* 新規部品

## ■ REMOTE CONTROL

### • PANELS

CDX-497 (R, T, K, A, B, G, J models)    CDX-397 (R, T, A, B, G models)

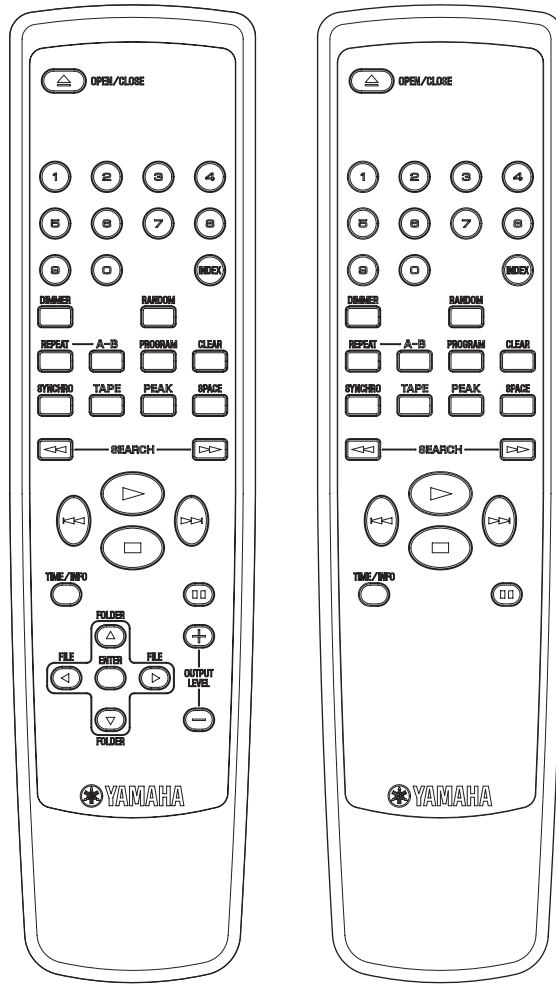

CDX-497 model

### • KEY CODE

Key label	Code
OPEN/CLOSE	79-01
1	79-11
2	79-12
3	79-13
4	79-14
5	79-15
6	79-16
7	79-17
8	79-18
9	79-19
0	79-10
INDEX	79-0B
DIMMER	79-1E
RANDOM	79-1B
REPEAT	79-08
REPEAT A-B	79-09
PROGRAM	79-0C
CLEAR	79-0D
SYNCHRO	79-58
TAPE	79-57
PEAK	79-5D
SPACE	79-0F
◀◀ SEARCH	79-05
SEARCH ▶▶	79-06
PLAY	79-02
◀◀ SKIP	79-04
SKIP ▶▶	79-07
STOP	79-56
TIME/INFO	79-0A
PAUSE	79-55
▲ FOLDER +	79-69
OUTPUT LEVEL +	79-1D
◀ FILE -	79-6C
ENTER	79-3F
▶ FILE +	79-6B
▼ FOLDER -	79-6A
OUTPUT LEVEL -	79-1C

# CDX-497/CDX-397

