



Service Manual



Service Manual

B2070



Model : B2070

Table Of Contents

1. INTRODUCTION.....	2	5. DOWNLOAD AND CALIBRATION	91
1.1 Purpose	2	5.1 Download	91
1.2 Regulatory Information	2	5.2 Calibration	96
1.3 Abbreviations	4		
2. PERFORMANCE	6	6. BLOCK DIAGRAM.....	99
2.1 H/W Feature	6		
2.2 Technical Specification	8	7. CIRCUIT DIAGRAM	101
3. TECHNICAL BRIEF	13	8. PCB LAYOUT	106
3.1 Transceiver	13		
3.2 Power Amplifier Module	19	9. ENGINEERING MODE	109
3.3 13 MHz Clock	20	9.1 BB Test [MENU 1].....	110
3.4 Power Supplies of RF circuits	20	9.2 RF Test [MENU 2].....	111
3.5 Digital Main Processor	22	9.3 MF mode [MENU 3].....	112
3.6 Analog Main & Power Management Processor	28	9.4 Trace option [MENU 4].....	113
3.7 Display Interface	38	9.5 Call timer [MENU 5].....	113
3.8 Radio Interface	40	9.6 Fact. Reset [MENU 6]	113
3.9 Keypad Switches and Scanning	41	9.7 S/W version [MENU 7]	113
3.10 Microphone	42	10. STAND ALONE TEST.....	114
3.11 Main Speaker	42	10.1 Introduction	114
3.12 Headset interface	43	10.2 Setting Method.....	114
3.13 Key Back-light Illumination	44	10.3 Means of Test	115
3.14 Vibrator	45		
4. TROUBLE SHOOTING	46	11. AUTO CALIBRATION	117
4.1 RX Trouble	46	11.1 Overview.....	117
4.2 TX Trouble	53	11.2 Requirements.....	117
4.3 Power On Trouble	61	11.3 Menu and Settings	117
4.4 Charging Trouble.....	63	11.4 AGC.....	119
4.5 Vibrator Trouble.....	65	11.5 APC.....	119
4.6 LCD Trouble.....	67	11.6 ADC.....	119
4.7 Radio Trouble	69	11.7 Setting.....	119
4.8 Speaker Trouble	71	11.8 How to do calibration.....	119
4.9 SIM card interface trouble	74	12. EXPLODED VIEW & REPLACEMENT PART LIST ..	121
4.10 Earphone Trouble	76	12.1 Exploded View	121
4.11 Key Backlight Trouble	78	12.2 Replacement Parts	
4.12 Receiver Trouble	80	<Mechanic component>.....	123
4.13 Microphone Trouble	82	<Main component>.....	125
4.14 RTC Trouble.....	84	12.3 Accessory	138
4.15 Indication LED Trouble.....	86		
4.16 PTT Trouble	88		
4.17 Speakerphone Trouble	89		

1. INTRODUCTION

1.1 Purpose

This manual provides the information necessary to repair, calibration, description and download the features of this model.

1.2 Regulatory Information

A. Security

Toll fraud, the unauthorized use of telecommunications system by an unauthorized part (for example, persons other than your company's employees, agents, subcontractors, or person working on your company's behalf) can result in substantial additional charges for your telecommunications services. System users are responsible for the security of own system. There are may be risks of toll fraud associated with your telecommunications system. System users are responsible for programming and configuring the equipment to prevent unauthorized use. The manufacturer does not warrant that this product is immune from the above case but will prevent unauthorized use of common-carrier telecommunication service of facilities accessed through or connected to it.

The manufacturer will not be responsible for any charges that result from such unauthorized use.

B. Incidence of Harm

If a telephone company determines that the equipment provided to customer is faulty and possibly causing harm or interruption in service to the telephone network, it should disconnect telephone service until repair can be done. A telephone company may temporarily disconnect service as long as repair is not done.

C. Changes in Service

A local telephone company may make changes in its communications facilities or procedure. If these changes could reasonably be expected to affect the use of the this phone or compatibility with the network, the telephone company is required to give advanced written notice to the user, allowing the user to take appropriate steps to maintain telephone service.

D. Maintenance Limitations

Maintenance limitations on this model must be performed only by the manufacturer or its authorized agent. The user may not make any changes and/or repairs except as specifically noted in this manual. Therefore, note that unauthorized alternations or repair may affect the regulatory status of the system and may void any remaining warranty.

E. Notice of Radiated Emissions

This model complies with rules regarding radiation and radio frequency emission as defined by local regulatory agencies. In accordance with these agencies, you may be required to provide information such as the following to the end user.

F. Pictures

The pictures in this manual are for illustrative purposes only; your actual hardware may look slightly different.

G. Interference and Attenuation

Phone may interfere with sensitive laboratory equipment, medical equipment, etc. Interference from unsuppressed engines or electric motors may cause problems.

H. Electrostatic Sensitive Devices

ATTENTION

Boards, which contain Electrostatic Sensitive Device (ESD), are indicated  by the sign. Following information is ESD handling:

- Service personnel should ground themselves by using a wrist strap when exchange systemboards.
- When repairs are made to a system board, they should spread the floor with anti-static mat which is also grounded.
- Use a suitable, grounded soldering iron.
- Keep sensitive parts in these protective packages until these are used.
- When returning system boards or parts like EEPROM to the factory, use the protective package as described.

1.3 Abbreviations

For the purposes of this manual, following abbreviations apply:

APC	Automatic Power Control
BB	Baseband
BER	Bit Error Ratio
CC-CV	Constant Current – Constant Voltage
DAC	Digital to Analog Converter
DCS	Digital Communication System
dBm	dB relative to 1 milli watt
DSP	Digital Signal Processing
EEPROM	Electrical Erasable Programmable Read-Only Memory
ESD	Electrostatic Discharge
FPCB	Flexible Printed Circuit Board
GMSK	Gaussian Minimum Shift Keying
GPIB	General Purpose Interface Bus
GSM	Global System for Mobile Communications
IPIU	International Portable User Identity
IF	Intermediate Frequency
LCD	Liquid Crystal Display
LDO	Low Drop Output
LED	Light Emitting Diode
OPLL	Offset Phase Locked Loop

PAM	Power Amplifier Module
PCB	Printed Circuit Board
PGA	Programmable Gain Amplifier
PLL	Phase Locked Loop
PSTN	Public Switched Telephone Network
RF	Radio Frequency
RLR	Receiving Loudness Rating
RMS	Root Mean Square
RTC	Real Time Clock
SAW	Surface Acoustic Wave
SIM	Subscriber Identity Module
SLR	Sending Loudness Rating
SRAM	Static Random Access Memory
PSRAM	Pseudo SRAM
STMR	Side Tone Masking Rating
TA	Travel Adapter
TDD	Time Division Duplex
TDMA	Time Division Multiple Access
UART	Universal Asynchronous Receiver/Transmitter
VCO	Voltage Controlled Oscillator
VCTCXO	Voltage Control Temperature Compensated Crystal Oscillator
WAP	Wireless Application Protocol

2. PERFORMANCE

2.1 H/W Features

Item	Feature	Comment
Standard Battery	Li-ion, 780 mAh Battery Size: 105.5(W) x 44(H) x 15.8(T) [mm] Battery Weight: TBD	
Stand by Current	Under the minimum current consumption environment (such as paging period 9), the level of standby current is below 4mA.	
Talk time	Up to 2 hours (GSM TX Level 5)	
Stand by time	Up to 200 hours (Paging Period: 9, RSSI: -85 dBm)	
Charging time	Approx. Under 3.75 hours	
RX Sensitivity	GSM, EGSM: -104dBm, DCS: -104dBm	
TX output power	GSM, EGSM: 33dBm (Level 5), DCS PCS: 30dBm (Level 0)	
GPRS compatibility	Class 10	
SIM card type	3V Small Only	
Display	Main LCD : CSTN 128 x 128 pixel 65K Color	
Status Indicator	Hard icons. Key Pad 0 ~ 9, #, *, 4 Menu Key, Clear Key Send Key, END/PWR Key Soft Key(Left/Right)	
ANT	Internal	
EAR Phone Jack	Yes (stereo)	
PC Synchronization	Yes	
Speech coding	EFR/FR/HR	
Data and Fax	Yes	
Vibrator	Yes	
Loud Speaker	No	
Voice Recording	Yes	
Microphone	Yes	

Item	Feature	Comment
Speaker / Receiver	One way dual speaker	
Travel Adapter	Yes	
MIDI	40 Poly (Mono SPK)	
MP3/AAC	No	
Options	Data Cable	

2.2 Technical Specification

Item	Description	Specification																																																						
1	Frequency Band	EGSM TX : $890 + (n-1024) \times 0.2$ MHz RX : $935 + (n-1024) \times 0.2$ MHz (n=975~1024) DCS TX : $1710 + (n-512) \times 0.2$ M z RX : $1805 + (n-512) \times 0.2$ MHz (n=512~885) PCS TX : $1810 + (n-512) \times 0.2$ MHz RX : $1905 + (n-512) \times 0.2$ MHz (n=512~885)																																																						
2	Phase Error	RMS < 5 degrees Peak < 20 degrees																																																						
3	Frequency Error	< 0.1 ppm																																																						
4	Power Level	GSM, EGSM																																																						
		<table border="1"> <thead> <tr> <th>Level</th> <th>Power</th> <th>Toler.</th> <th>Level</th> <th>Power</th> <th>Toler.</th> </tr> </thead> <tbody> <tr> <td>5</td> <td>33dBm</td> <td>±2dB</td> <td>13</td> <td>17dBm</td> <td>± 3dB</td> </tr> <tr> <td>6</td> <td>31dBm</td> <td>±3dB</td> <td>14</td> <td>15dBm</td> <td>± 3dB</td> </tr> <tr> <td>7</td> <td>29dBm</td> <td>±3dB</td> <td>15</td> <td>13dBm</td> <td>± 3dB</td> </tr> <tr> <td>8</td> <td>27dBm</td> <td>±3dB</td> <td>16</td> <td>11dBm</td> <td>± 5dB</td> </tr> <tr> <td>9</td> <td>25dBm</td> <td>±3dB</td> <td>17</td> <td>9dBm</td> <td>± 5dB</td> </tr> <tr> <td>10</td> <td>23dBm</td> <td>±3dB</td> <td>18</td> <td>7dBm</td> <td>± 5dB</td> </tr> <tr> <td>11</td> <td>21dBm</td> <td>±3dB</td> <td>19</td> <td>5dBm</td> <td>± 5dB</td> </tr> <tr> <td>12</td> <td>19dBm</td> <td>±3dB</td> <td></td> <td></td> <td></td> </tr> </tbody> </table>	Level	Power	Toler.	Level	Power	Toler.	5	33dBm	±2dB	13	17dBm	± 3dB	6	31dBm	±3dB	14	15dBm	± 3dB	7	29dBm	±3dB	15	13dBm	± 3dB	8	27dBm	±3dB	16	11dBm	± 5dB	9	25dBm	±3dB	17	9dBm	± 5dB	10	23dBm	±3dB	18	7dBm	± 5dB	11	21dBm	±3dB	19	5dBm	± 5dB	12	19dBm	±3dB			
		Level	Power	Toler.	Level	Power	Toler.																																																	
		5	33dBm	±2dB	13	17dBm	± 3dB																																																	
		6	31dBm	±3dB	14	15dBm	± 3dB																																																	
		7	29dBm	±3dB	15	13dBm	± 3dB																																																	
		8	27dBm	±3dB	16	11dBm	± 5dB																																																	
		9	25dBm	±3dB	17	9dBm	± 5dB																																																	
		10	23dBm	±3dB	18	7dBm	± 5dB																																																	
		11	21dBm	±3dB	19	5dBm	± 5dB																																																	
		12	19dBm	±3dB																																																				
		DCS, PCS																																																						
		<table border="1"> <thead> <tr> <th>Level</th> <th>Power</th> <th>Toler.</th> <th>Level</th> <th>Power</th> <th>Toler.</th> </tr> </thead> <tbody> <tr> <td>0</td> <td>30dBm</td> <td>±2dB</td> <td>8</td> <td>14dBm</td> <td>± 3dB</td> </tr> <tr> <td>1</td> <td>28dBm</td> <td>±3dB</td> <td>9</td> <td>12dBm</td> <td>± 4dB</td> </tr> <tr> <td>2</td> <td>26dBm</td> <td>±3dB</td> <td>10</td> <td>10dBm</td> <td>± 4dB</td> </tr> <tr> <td>3</td> <td>24dBm</td> <td>±3dB</td> <td>11</td> <td>8dBm</td> <td>± 4dB</td> </tr> <tr> <td>4</td> <td>22dBm</td> <td>±3dB</td> <td>12</td> <td>6dBm</td> <td>± 4dB</td> </tr> <tr> <td>5</td> <td>20dBm</td> <td>±3dB</td> <td>13</td> <td>4dBm</td> <td>± 4dB</td> </tr> <tr> <td>6</td> <td>18dBm</td> <td>±3dB</td> <td>14</td> <td>2dBm</td> <td>± 5dB</td> </tr> <tr> <td>7</td> <td>16dBm</td> <td>±3dB</td> <td>15</td> <td>0dBm</td> <td>± 5dB</td> </tr> </tbody> </table>	Level	Power	Toler.	Level	Power	Toler.	0	30dBm	±2dB	8	14dBm	± 3dB	1	28dBm	±3dB	9	12dBm	± 4dB	2	26dBm	±3dB	10	10dBm	± 4dB	3	24dBm	±3dB	11	8dBm	± 4dB	4	22dBm	±3dB	12	6dBm	± 4dB	5	20dBm	±3dB	13	4dBm	± 4dB	6	18dBm	±3dB	14	2dBm	± 5dB	7	16dBm	±3dB	15	0dBm	± 5dB
		Level	Power	Toler.	Level	Power	Toler.																																																	
		0	30dBm	±2dB	8	14dBm	± 3dB																																																	
		1	28dBm	±3dB	9	12dBm	± 4dB																																																	
		2	26dBm	±3dB	10	10dBm	± 4dB																																																	
		3	24dBm	±3dB	11	8dBm	± 4dB																																																	
		4	22dBm	±3dB	12	6dBm	± 4dB																																																	
		5	20dBm	±3dB	13	4dBm	± 4dB																																																	
6	18dBm	±3dB	14	2dBm	± 5dB																																																			
7	16dBm	±3dB	15	0dBm	± 5dB																																																			

Item	Description	Specification	
5	Output RF Spectrum (due to modulation)	GSM, EGSM	
		Offset from Carrier (kHz).	Max. dBc
		100	+0.5
		200	-30
		250	-33
		400	-60
		600 ~ <1,200	-60
		1,200 ~ <1,800	-60
		1,800 ~ <3,000	-63
		3,000 ~ <6,000	-65
		6,000	-71
		DCS, PCS,	
		Offset from Carrier (kHz).	Max. dBc
		100	+0.5
		200	-30
		250	-33
		400	-60
		600 ~ <1,200	-60
		1,200 ~ <1,800	-60
		1,800 ~ <3,000	-65
3,000 ~ <6,000	-65		
6,000	-73		
6	Output RF Spectrum (due to switching transient)	GSM, EGSM	
		Offset from Carrier (kHz).	Max. dBm
		400	-19
		600	-21
		1,200	-21
		1,800	-24

2. PERFORMANCE

Item	Description	Specification		
6	Output RF Spectrum (due to switching transient)	DCS, PCS		
		Offset from Carrier (kHz).	Max. dBm	
		400	-22	
		600	-24	
		1,200	-24	
		1,800	-27	
7	Spurious Emissions	Conduction, Emission Status		
8	Bit Error Ratio	GSM, EGSM BER (Class II) < 2.439% @-102 dBm		
		DCS, EGSM BER (Class II) < 2.439% @-100 dBm		
9	RX Level Report Accuracy	± 3 dB		
10	SLR	8 ± 3 dB		
11	Sending Response	Frequency (Hz)	Max.(dB)	Min.(dB)
		100	-12	-
		200	0	-
		300	0	-12
		1,000	0	-6
		2,000	4	-6
		3,000	4	-6
		3,400	4	-9
		4,000	0	-
12	RLR	2 ± 3 dB		

Item	Description	Specification			
		Frequency (Hz)	Max. (dB)	Min. (dB)	
13	Receiving Respons	100	-12	-	
		200	0	-	
		300	2	-7	
		500	*	-5	
		1,000	0	-5	
		3,000	2	-5	
		3,400	2	-10	
		4,000	2		
		* Mean that Adopt a straight line in between 300 Hz and 1,000 Hz to be Max. level in the range.			
		14	STMR	13 ± 5 dB	
15	Stability Margin	> 6 dB			
16	Distortion	dB to ARL (dB)		Level Ratio (dB)	
		-35		17.5	
		-30		22.5	
		-20		30.7	
		-10		33.3	
		0		33.7	
		7		31.7	
		10		25.5	
17	Side Tone Distortion	Three stage distortion < 10%			
18	System Frequency (13 MHz) Tolerance	≤ 2.5 ppm			
19	32.768KHz Tolerance	≤ 30 ppm			
20	Ringer Volume	At least 65 dBspl under below conditions: 1. Ringer set as ringer. 2. Test distance set as 50 cm.			

2. PERFORMANCE

Item	Description	Specification	
21	Charge Current	Fast Charge : < 430 mA Slow Charge : < 160 mA	
22	Antenna Display	Antenna Bar Number	Power
		5	-85 dBm ~
		4	-90 dBm ~ -86 dBm
		3	-95 dBm ~ -91 dBm
		2	-100 dBm ~ -96 dBm
		1	-105 dBm ~ -101 dBm
		0	~ -105 dBm
23	Battery Indicator	Battery Bar Number	Voltage
		0	3.36 ~ 3.58V
		1	3.59 ~ 3.66V
		2	3.67 ~ 3.73V
		3	3.74V ~ 3.87V
		4	3.88V ~
24	Low Voltage Warning	3.59 ± 0.03V (Call)	
		3.50 ± 0.03V (Standby)	
25	Forced shut down Voltage	3.35 ± 0.03V	
26	Battery Type	1 Li-ion Battery Standard Voltage = 3.7V Battery full charge voltage = 4.2V Capacity : 780mAh	
27	Travel Charger	Switching-mode charger Input : 100 ~ 240V, 50/60 Hz Output : 5.2V, 800 mA	

3. TECHNICAL BRIEF

3.1 Transceiver (SI4205-BM, U500)

The RF parts consist of a transmitter part, a receiver part, a frequency synthesizer part, a voltagesupply part, and a VCTCXO part.

The Aero I transceiver is the integrated RF front end for multi-band GSM/GPRS digital cellular handsets and wireless data modems. The integrated solution eliminates the IF SAW filter, external low noise amplifier (LNAs) for three bands, transmit and RF voltage controlled oscillator(VCO modules, and other discrete components found in conventional designs.

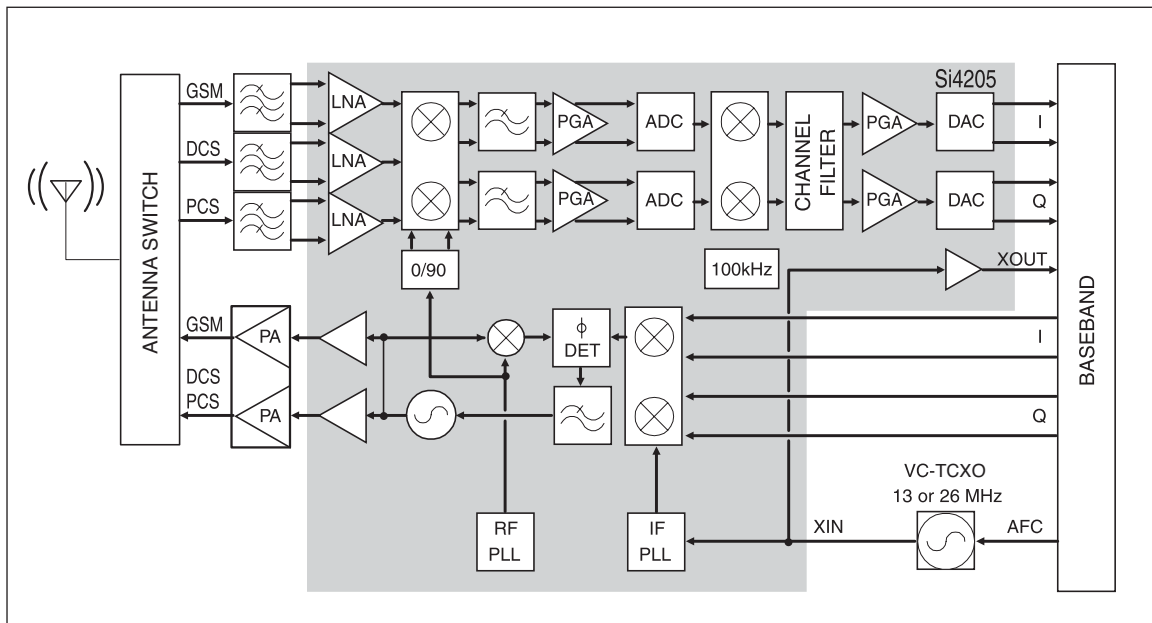

Figure 3-1 RECEIVER FUNCTIONAL BLOCK DIAGRAM

(1) Receiver Part

The Aero I transceiver uses a low-IF receiver architecture which allows for the on chip integration of the channel selection filters, eliminating the external RF imagereject filters and the IF SAW filter required in conventional super-heterodyne architectures.

A. RF front end

RF front end consists of Front End Module(FL500) and Quad band LNAs integrated in transceiver (U500).

The Received RF signals(GSM 925MHz ~ 960MHz, DCS 1805MHz ~ 1880MHzPCS 1930MHz ~ 1990MHz) are fed into the antenna or Mobile switch. The Front End Module(FL500) is used to control the Rx and Tx paths. And, the input signals VC1, VC2, VC3 of a FL501 are directly connected to baseband controller to switch either Tx or Rx path on.

	VC1	VC2	VC3
GSM Tx	0 V	0 V	2.5 ~ 3.0 V
DCS, PCS Tx	0 V	2.5 ~ 3.0 V	0 V
GSM / DCS Rx	0 V	0 V	0 V
PCS / DCS Rx	2.5 ~ 3.0 V	0 V	0 V

Table 3-1 THE LOGIC AND CURRENT

The logic and current is given below Table 3-1.

Three differential-input LNAs are integrated in SI4205. The GSM input supports the GSM850 (869-849 MHz) or E-GSM 900 (925-960MHz) bands. The DCS input supports theDCS 1800 (1805-1880 MHz) band. The PCS input supports the PCS 1900 (1930-1990MHz) band.

The LNA inputs are matched to the 150Ω balanced output SAW filters through external LC matching networks. The LNA gain is controlled with the LNAG[1:0] and LNAC[1:0] bits in register 05h (Figure 3-2).

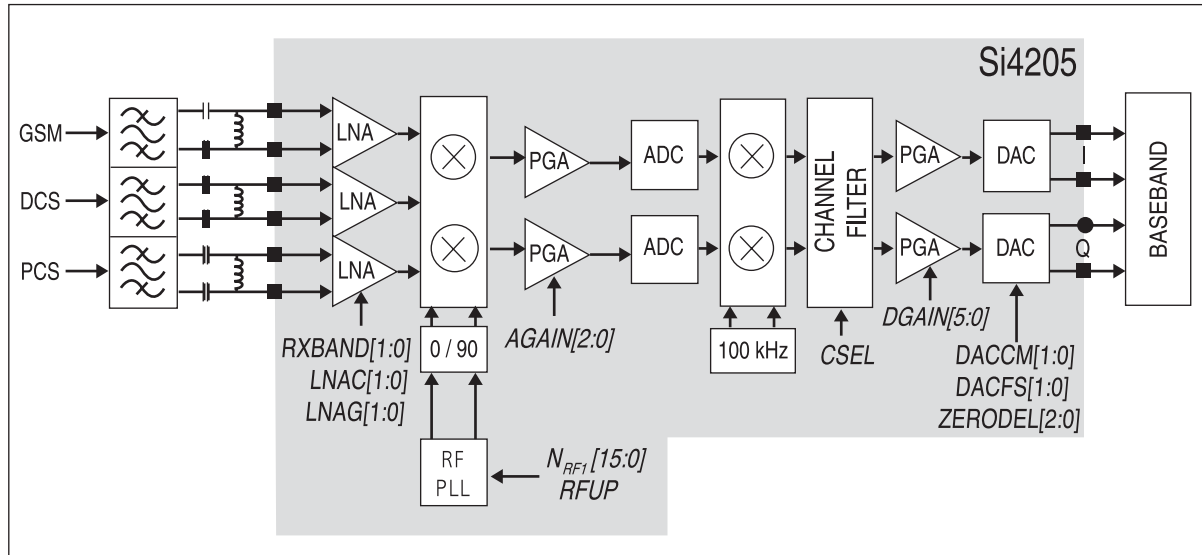

Figure 3-2 SI4205 RECEIVER PART

B. Intermediate frequency (IF) and Demodulation

A quadrature image-reject mixer downconverts the RF signal to a 100KHz intermediate frequency (IF) with the RFLO from the frequency synthesizer. The RFLO frequency is between 1737.8 to 1989.9 MHz, and is internally divided by 2 for GSM 850 and E-GSM 900 modes. The mixer output is amplified with an analog programmable gain amplifier (PGA), which is controlled with the AGAIN[2:0] bits in register 05h (Figure3-2). The quadrature IF signal is digitized with high resolution A/D converters (ADCs).

The ADC output is downconverted to baseband with a digital 100KHz quadrature LO signal. Digital decimation and IIR filters perform channel selection to remove blocking and reference interference signals. The selectivity setting (CSEL=0) or a low selectivity setting (CSEL=1). The low selectivity filter has a flatter group channelization filter is in the baseband chip. After channel selection, the digital output is scaled with a digital PGA, which is controlled with the DGAIN [5:0] bits in register 05h.

The amplified digital output signal go through with DACs that drive a differential analog signal onto the RXIP,RXIN,RXQP and RXQN pins to interface to standard analog ADC input baseband ICs. No special processing is required in the baseband for offset compensation or extended dynamic range.

Compared to a direct-conversion architecture, the low-IF architecture has a much greater degree of immunity to dc offsets that can arise from RF local oscillator(RFLO) self-mixing, 2nd order distortion of blockers, and device 1/f noise.

(2) Transmitter Part

The transmit (Tx) section consists of an I/Q baseband upconverter, and offset phase-locked loop (OPLL) and two output buffers that can drive external poweramplifiers (PA), one for the GSM 850 (824-849 MHz) and E-GSM 900 (880-915 MHz) bands and one for the DCS 1800 (1710-1785 MHz) and PCS 1900 (1850-1910MHz) bands.

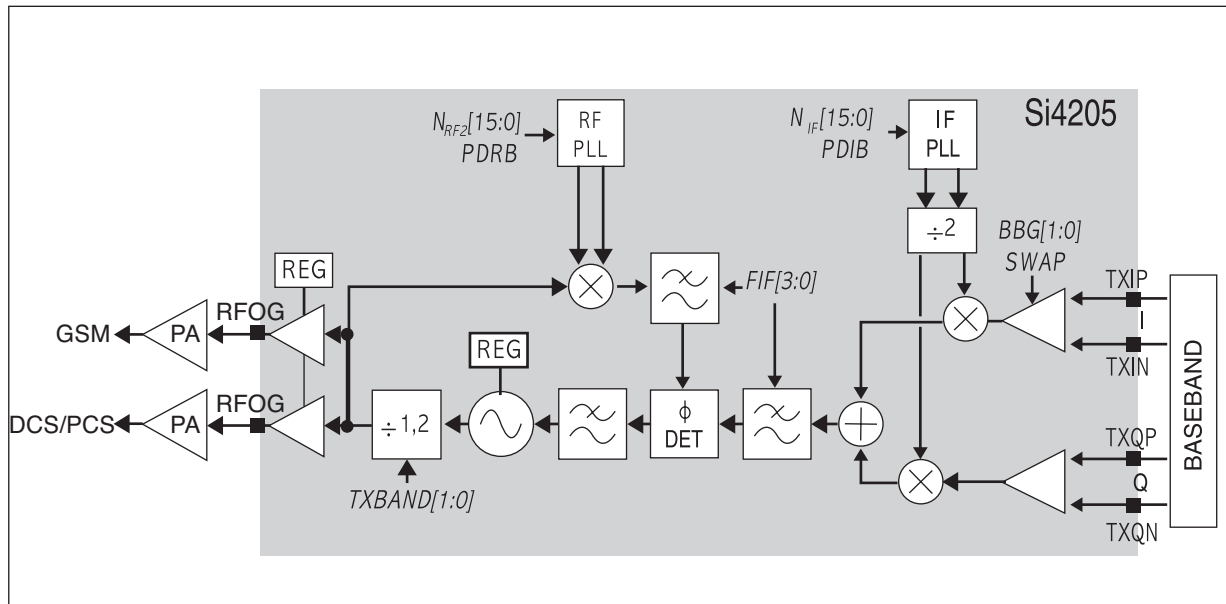

Figure 3-3 SI4205 TRANSMITTER PART

A. IF Modulator

The baseband converter(BBC) within the GSM chipset generates I and Q baseband signals for the Transmit vector modulator. The modulator provides more than 40dBc of carrier and unwanted sideband rejection and produces a GMSK modulated signal. The baseband software is able to cancel out differential DC offsets in the I/Q baseband signals caused by imperfections in the D/A converters.

The Tx-Modulator implements a quadrature modulator. A quadrature mixer upconverts the differential in-phase (TXIP, TXIN) and quadrature(TXQP, TXQN) signals with the IFLO to generate a SSB IF signal that is filtered and used as the reference input to the OPLL.

The IFLO frequency is generated between 766 and 896 MHz and internally divided by 2 to generate the quadrature LO signals for the quadrature modulator, resulting in an IF between 383 and 448 MHz. For the E-GSM 900 band, two different IFLO frequencies are required for spur management. Therefore, the IF PLL must be programmed per channel in the E-GSM 900 band.

B. OPLL

The OPLL consists of a feedback mixer, a phase detector, a loop filter, and a fully integrated TXVCO. The TXVCO is centered between the DCS 1800 and PCS 1900 bands, and its output is divided by 2 for the GSM 850 and E-GSM 900 bands. The RFLO frequency is generated between 1272 and 1483 MHz. To allow a single VCO to be used for the RFLO, high-side injection is used for the GSM 850 and E-GSM 900 bands, and low-side injection is used for the DCS 1800 and PCS 1900 bands. The I and Q signals are automatically swapped when switching bands. Additionally, the SWAP bit in register 03h can be used to manually exchange the I and Q signals.

Low-pass filters before the OPLL phase detector reduce the harmonic content of the quadrature modulator and feedback mixer outputs. The cutoff frequency of the filters is programmable with the FIF[3:0] bits in register 04h (Figure 3-3), and should be set to the recommended settings detailed in the register description.

(3) Frequency Synthesizer

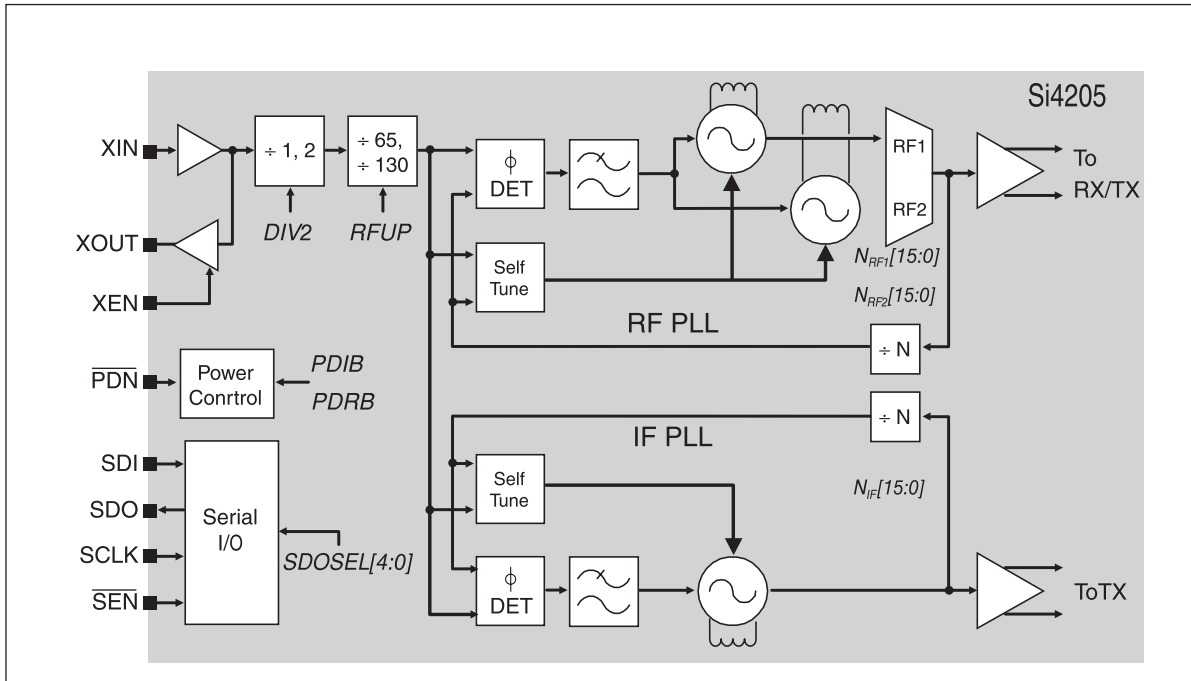

Figure 3-4 SI4205 FREQUENCY SYNTHESIZER PART

The Aero I transceiver integrates two complete PLLs including VCOs, varactors, resonators, loop filters, reference and VCO dividers, and phase detectors. The RF PLL uses two multiplexed VCOs. The RF1 VCO is used for receive mode, and the RF2 VCO is used for transmit mode. The IF PLL is used only during transmit mode. All VCO tuning inductors are also integrated. The IF and RF output frequencies are set by programming the N-Divider registers, N_{RF1} , N_{RF2} and N_{IF} . Programming the N-Divider register for either RF1 or RF2 automatically selects the proper VCO. The output frequency of each PLL is as follows:

$$f_{out} = N \times f_{\phi}$$

The DIV2 bit in register 31h controls a programmable divider at the XIN pin to allow either a 13 or 26 MHz reference frequency. For receive mode, the RF1 PLL phase detector update rate (f_{ϕ}) should be programmed $f_{\phi} = 100$ kHz for DCS 1800 or PCS 1900 bands, and $f_{\phi} = 200$ kHz for GSM 850 and E-GSM 900 bands. For transmit mode, the RF2 and IF PLL phase detector update rates are always $f_{\phi} = 200$ kHz.

3.2 Power Amplifier Module (RF3166, U501)

The RF3166 is a high-power, high-efficiency power amplifier module with integrated power control that provides over 50dB of control range. The device is a self-contained 6mmx6mm module with 50Ω input and output terminals.

The device is designed for use as the final RF amplifier in GSM850, EGSM900, DCS and PCS handheld digital cellular equipment and other applications in the 824MHz to 849MHz, 880MHz to 915MHz, 1710MHz to 1785MHz and 1850MHz to 1910MHz bands. The RF3166 incorporates RFMD's latest VBATT tracking circuit, which monitors battery voltage and prevents the power control loop from reaching saturation. The VBATT tracking circuit eliminates the need to monitor battery voltage, thereby minimizing switching transients. The RF3166 requires no external routing or external components, simplifying layout and reducing board space.

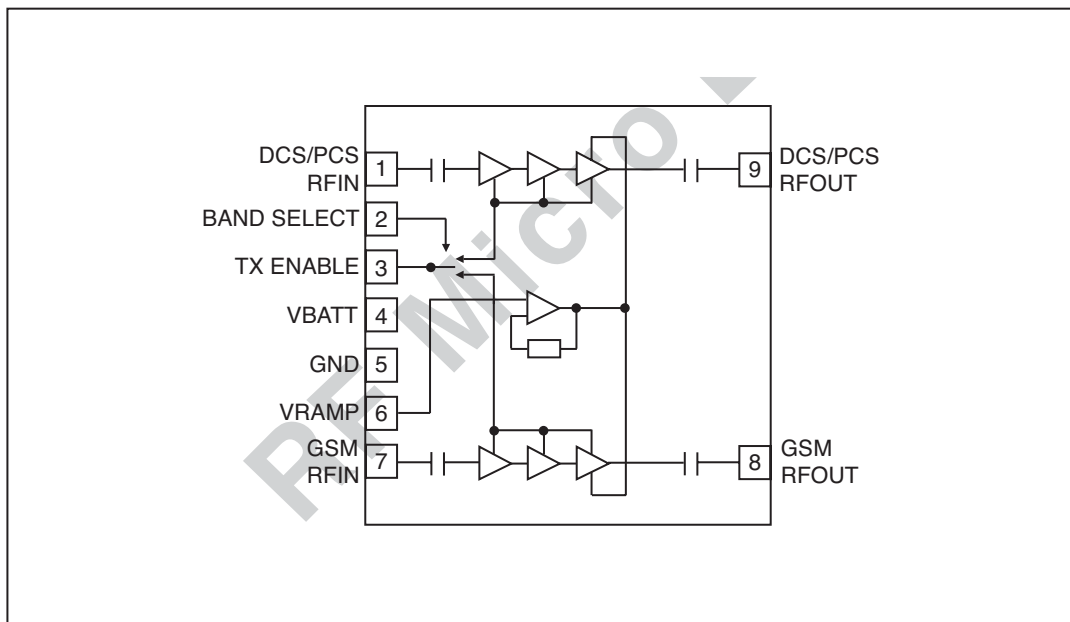

Figure 3-5 FUNCTIONAL BLOCK DIAGRAM

3.3 13 MHz Clock (VCTCXO, X500)

The 13 MHz clock(X500) consists of a TCXO(Temperature Compensated Crystal Oscillator) which oscillates at a frequency of 13 MHz. It is used within the Si4205, analog base band chipset (U101, AD6537B), digital base band chipset (U100, AD6527).

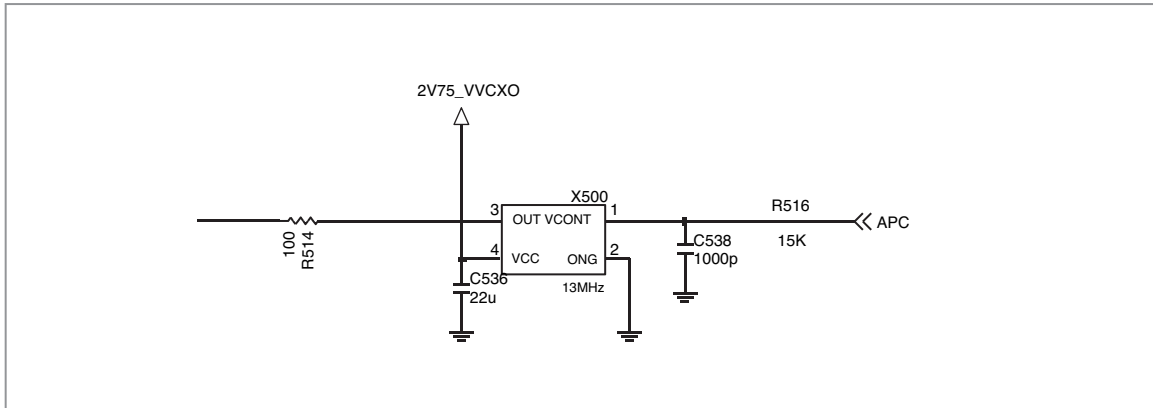

Figure 3-6 VCTCXO CIRCUIT DIAGRAM

3.4 Power Supplies for RF Circuits (RF LDO, U702)

Two regulators are used for RF circuits. One is MIC5255 (U702), and the other is one port of AD6537B (U101).

MIC5255 (U702) supplies power to transceiver (SI4205, U500). One port of AD6537B supplies power to VCTCXO (X500).

Supplier	Voltage	Powers	enabled signal
U702(VRF)	2.85 V	U500	
U101(VVCXO)	2.75 V	X500	
Battery(VBAT)	3.4 ~ 4.2 V	U501, U702	

Table 3-2 RF POWER SUPPLIERS

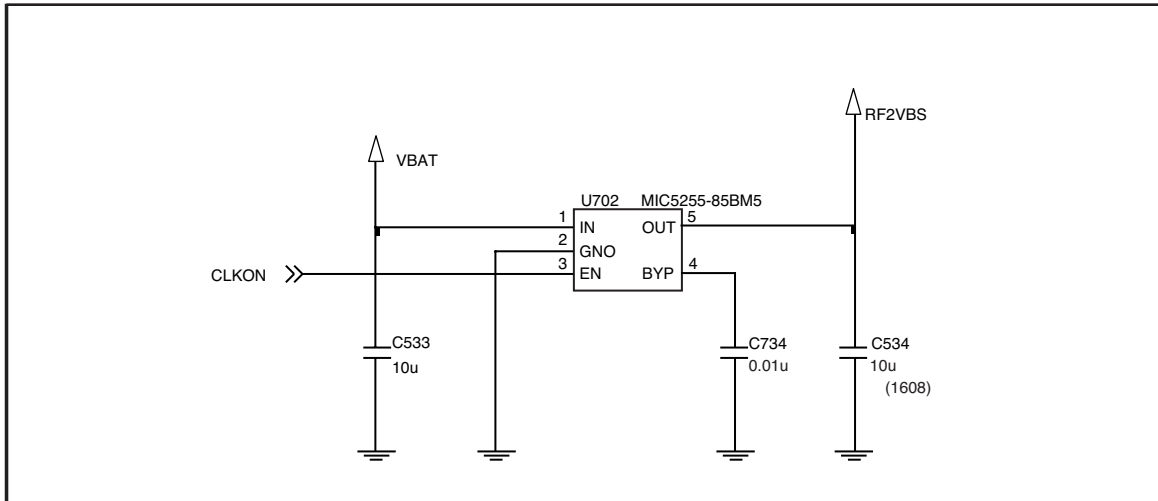

Table 3-7 RF LDO CIRCUIT DIAGRAM

3.5 Digital Main Processor (AD6527, U100)

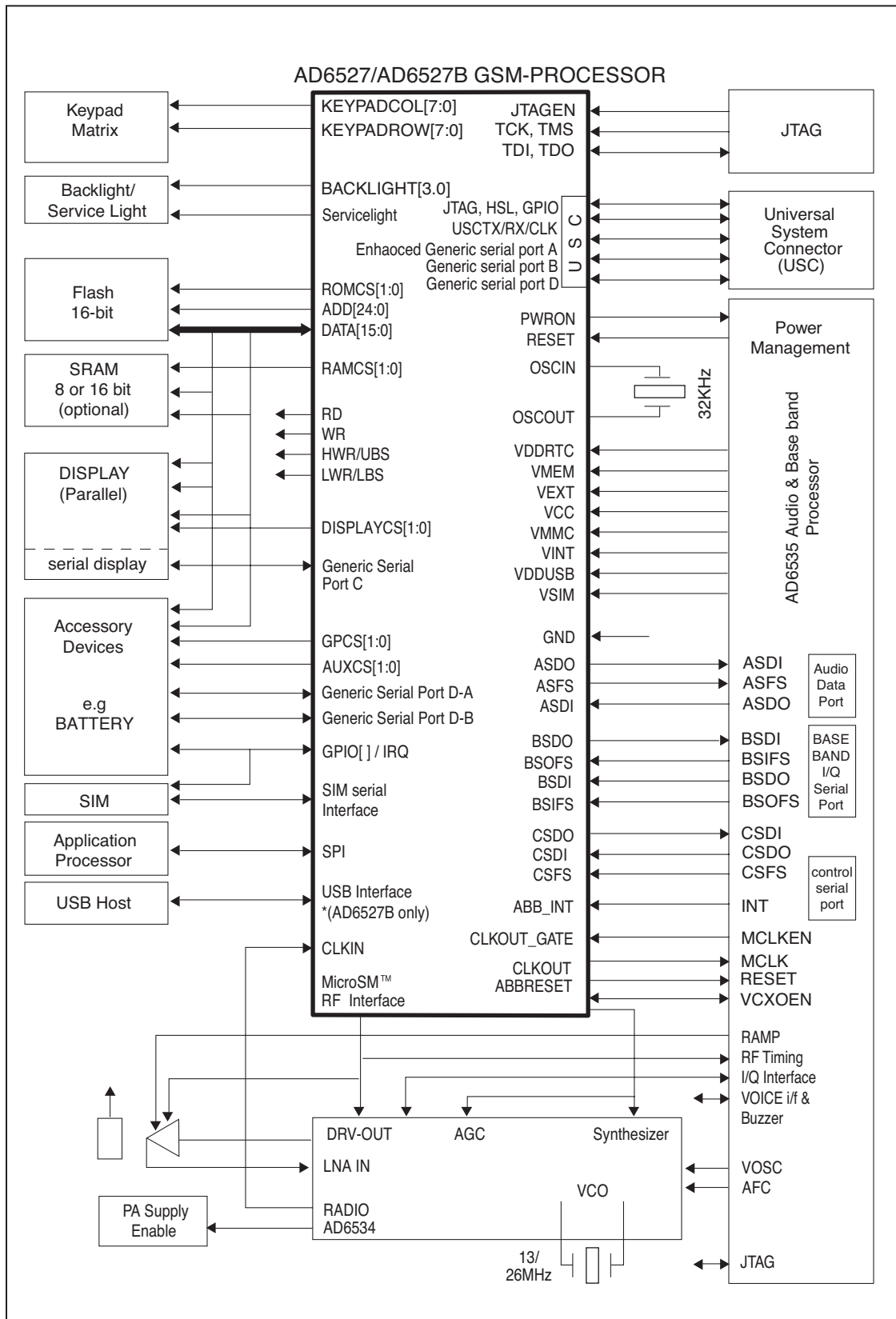

Figure 3-8 SYSTEM INTERCONNECTION OF AD6527 EXTERNAL INTERFACE

- AD6527 is an ADI designed processor

- AD6527 consists of
 1. Control Processor Subsystem
 - 32-bit ARM7TDMI Control Processor
 - 58.5 MHz operation at 1.7V
 - On-board 16KB instruction/Data Cache
 - 1 Mbits of on-chip System SRAM

 2. DSP Subsystem
 - 16-bit Fixed Point DSP Processor
 - 91 MIPS at 1.7V
 - 16K word Data and 16K word Program SRAM
 - 4K word Program Instruction Cache
 - Architecture supports Full Rate, Enhanced Full Rate, Half Rate, and AMR speech Encoding/Decoding Algorithms

 3. Peripheral Subsystem
 - Shared on-chip peripheral and off-chip interface:
 - Support for Burst and Page Mode Flash
 - Support for Pseudo SRAM
 - Ciphering module for GPRS supporting GAE1 and GAE2 encryption algorithms
 - Parallel and Serial Display Interface
 - 8 x 8 Keypad Interface
 - Four independent programmable backlight plus One Service Light
 - 1.8V and 3.0V, 64 kbps SIM interface
 - Universal System Connector Interface
 - Slow, Medium and Fast IrDA transceiver interface
 - Enhanced Generic Serial Port
 - Dedicated SPI interface
 - Thumbwheel Interface
 - JTAG Interface for Test and In-Circuit Emulation

 4. Other
 - Supports 13 MHz and 26 MHz Input Clocks
 - 1.8V Typical Core Operating Voltages
 - 204-Ball LFBGA(mini-BGA) Package

 5. Applications
 - GSM900/DCS1800/PCS1900/PCS850 Wireless Terminals
 - GSM Phase 2+ Compliant
 - GPRS Class 12 Compliant
 - Multimedia Services(MMS)
 - Extended Messaging System(EMS)

3.5.1 Interconnection with external devices

A. RTC block interface

Countered by external X-TAL
 The X-TAL oscillates 32.768KHz

B. LCD module interface

The LCD module is controlled by AD6527(U100),DBB.
 In operating mode, the AD6527(U100) controls the LCD module through _LCD_CS, LCD_DIM_CTRL, LCD_RESET, _WR, 2V8_VMEM, LCD_ID, LCD_BL_EN.

Signals	Description
_LCD_CS	MAIN LCD driver chip enable. MAIN LCD driver IC has own CS pin
LCD_DIM_CTRL	It controls dimming mode of LCD module. (GPIO_5)
LCD_RESET (GPIO 15)	This pin resets LCD module. This signal comes from DBB directly
_WR	Enable writing to LCD Driver.
2V8_VMEM	2.8V voltage is supplied to LCD driver IC
LCD_ID (GPIO 16)	It determines the maker of LCD module.
LCD_BL_EN	It controls back-light of LCD module. (GPO_23)

Table 3-3 LCD CONTRON SIGNALS DISCRPTION

The backlight of LCD module is controlled by DBB via TPS60230RGTR , U400.
The control signals related to Backlight LED are given bellow.

Signals	Description
LCD_DIM_CTL (GPO 5)	Control LCD backlight level in 16 steps
LCD_LED_CTL	Control LCD LED
LCD_LED_GND	
LCD_BL_EN	It Controls back-light of LCD module. (GPO_223)

Table 3-4 DESCRIPTION OF LCD BACKLIGHT LED CONTROL

C. RF interface

The AD6527 control RF parts through PA_BAND, ANT_SW1, ANT_SW2, ANT_SW2, CLKON, PA_EN, S_EN, S_DATA, S_CLK, RF_PWR_DWN.

Signal	Description
PA_BAND (GPO 17)	PAM Band Select
ANT_SW1 (GPO 9)	Antenna switch Band Select
ANT_SW2 (GPO 10)	Antenna switch Band Select
ANT_SW3 (GPO 11)	Antenna switch Band Select
CLKON	RF LDO Enable/Disable
PA_EN (GPO 16)	PAM Enable/Disable
S_EN (GPO 19)	PLL Enable/Disable
S_DATA (GPO 20)	Serial Data to PLL
S_CLK (GPO 21)	Clock to PLL
RF_PWR_DWN(GPO 4)	Power down Input

Table 3-5 RF CONTRON SIGNALS DISCRIPTION

3. TECHNICAL BRIEF

D. SIM interface

The AD6527 provides SIM Interface Module. The AD6527 checks status periodically during established call mode whether SIM card is inserted or not, but it doesn't check during deep Sleep mode. In order to communicate with SIM card, 3 signals SIM_DATA, SIM_CLK, SIM_RST(GPIO_23) are required.

The descriptions about the signals are given by bellow Table 3-6 in detail.

Signals	Description
LCD_DATA	This pin receives and sends data to SIM card. This model can support only 3.0 volt interface SIM card.
LCD_CLK	Clock 3.25MHz frequency.
SIM_RST (GPIO_23)	Reset SIM block

Table 3-6 SIM CONTRON SIGNALS DISCRIPTION

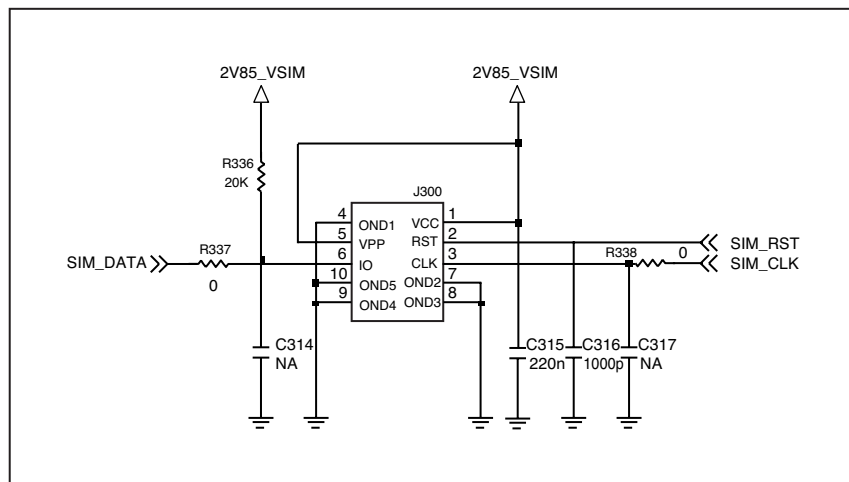

Figure 3-9 SIM Interface of AD6527

E. Key interface

Include 5 column, 5 row and additional GPIO 35 for KEY_ROW5.

The AD6527 detects whether key is pressed or not by using interrupt method.

F. AD6537B Interrupt

AD6537B provides an active-high interrupt output signal.

Interrupt signals are generated by the Auxiliary ADC, audio, and charger modules.

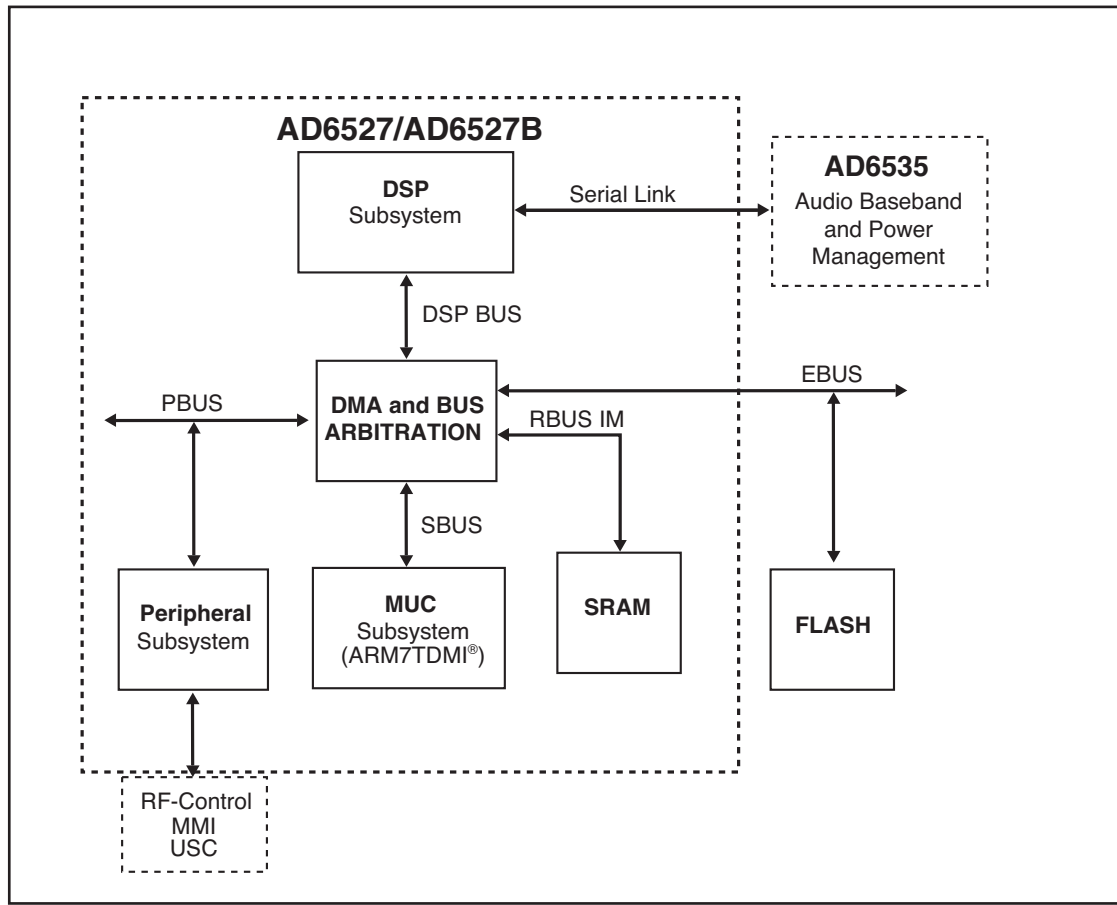

Figure 3-10 AD6527 ARCHITECTURE

The internal architecture of AD6527 is shown above Figure 3-10. AD6527 regroups three main subsystems connected together through a dynamic and flexible communication bus network. It also includes onboard system RAM (SRAM) and interfaces with external Flash Memory, Baseband converter functions, and terminal functions like MMI, SIM and Universal System Connector (USC).

The Digital Signal Processing (DSP) subsystem primarily hosts all the speech processing, channel equalization and channel codec functions. The code used to implement such functions can be stored in external Flash Memory and dynamically downloaded on demand into the DSP's program RAM and Instruction Cache.

The micro-controller subsystem supports all the GSM terminal software, including the layer 1, 2 and 3 of the GSM protocol stack, the MMI, and applications software such as data services, test and maintenance. It is tightly associated with on-chip system SRAM and also includes boot ROM memory with a small dedicated routine to facilitate the initialization of the external Flash Memory via code download using the on-chip serial interface to the external Flash Memory interface.

The peripheral subsystem is composed of system peripherals such as interrupt controller, real time clock, watch dog timer, power management and a timing and control module. It also includes peripheral interfaces to the terminal functions: keyboard, battery supervision, radio and display. Both the DSP and the MCU can access the peripheral subsystem via the peripheral bus (PBUS). For program and data storage, both the MCU subsystem and the DSP subsystem can access the on chip system SRAM and external memory such Flash Memory. The access to the SRAM module is made through the RAM Bus (RBUS) under the control of the bus arbitration logic. Similarly, access to the Flash Memory is through the parallel External Bus (EBUS).

3.6 Analog Main & Power Management Processor (AD6537B, U101)

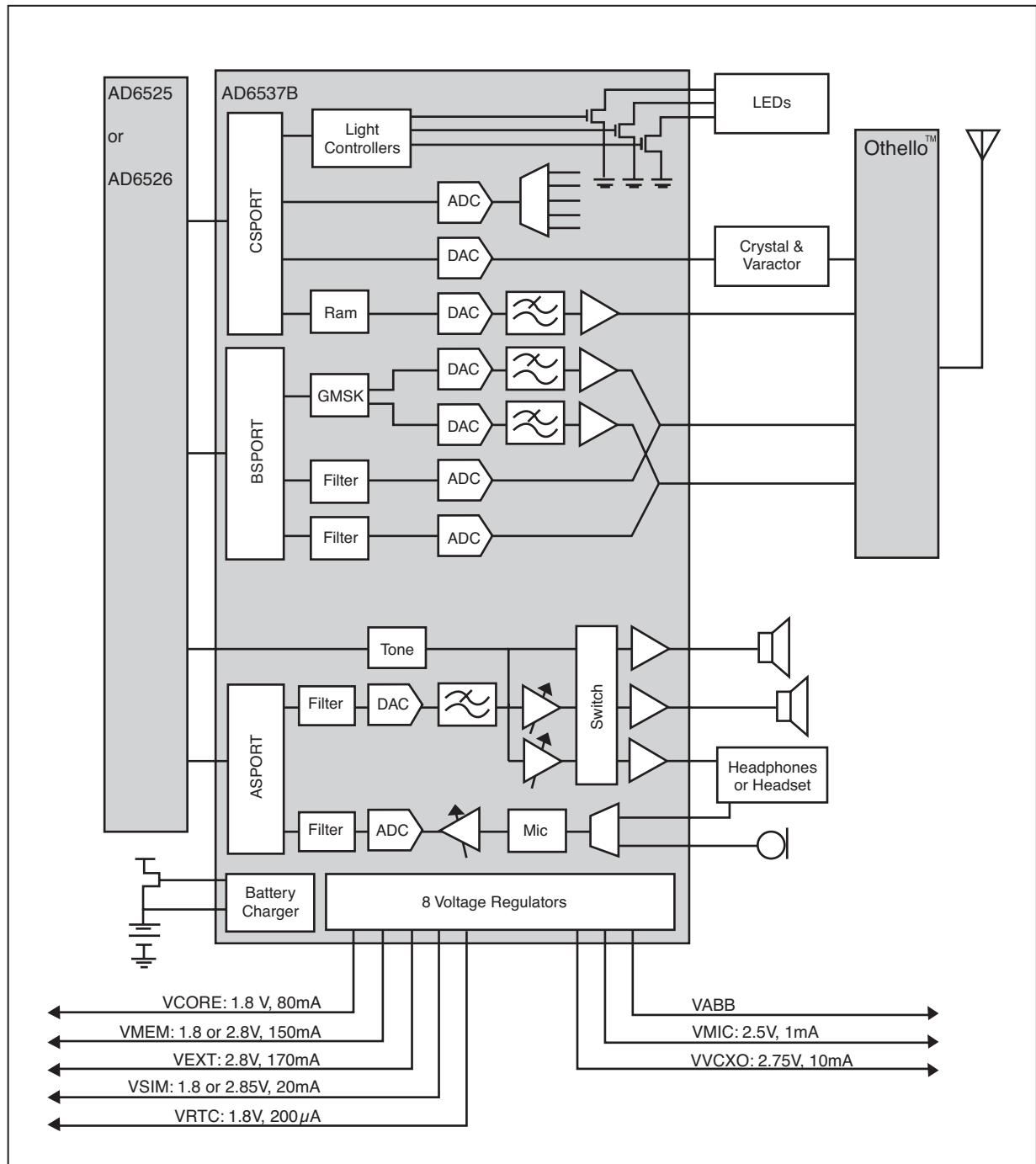

Figure 3-11 AD6537B FUNCTION BLOCK DIAGRAM

- AD6537B is an ADI designed Analog Baseband processor. AD6537B covers the processing GMSK modulation interface, Aux ADC, Voice signal processing and Power Management.

- AD6537B consists of
 1. BB Transmit section
 - GMSK Modulation
 - I-channel & Q-channel Transmit DACs and Filters
 - Power Ramping DAC

 2. BB Receive section
 - I-channel & Q-channel Receive ADCs and Filters

 3. Auxiliary section
 - Voltage Reference
 - Automatic Frequency Control DAC
 - Auxiliary ADC
 - Light Controllers

 4. Audio Section
 - 8 kHz & 16 kHz Voiceband Codec
 - 48 kHz Monophonic DAC
 - Power Amplifiers

 5. Power Management section
 - Voltage Regulators
 - Battery Charger
 - Battery Protection

 6. Digital Processor section
 - Control, Baseband, and Audio Serial Ports
 - Interrupt Logic

3.6.1 Baseband Transmit Section

1. The AD6537B Baseband Transmit Section is designed to support GMSK for both single-slot and multi-slot applications.
2. The transmit channel consists of a digital GMSK modulator, a matched pair of 10-bit DACs and a matched pair of reconstruction filters.

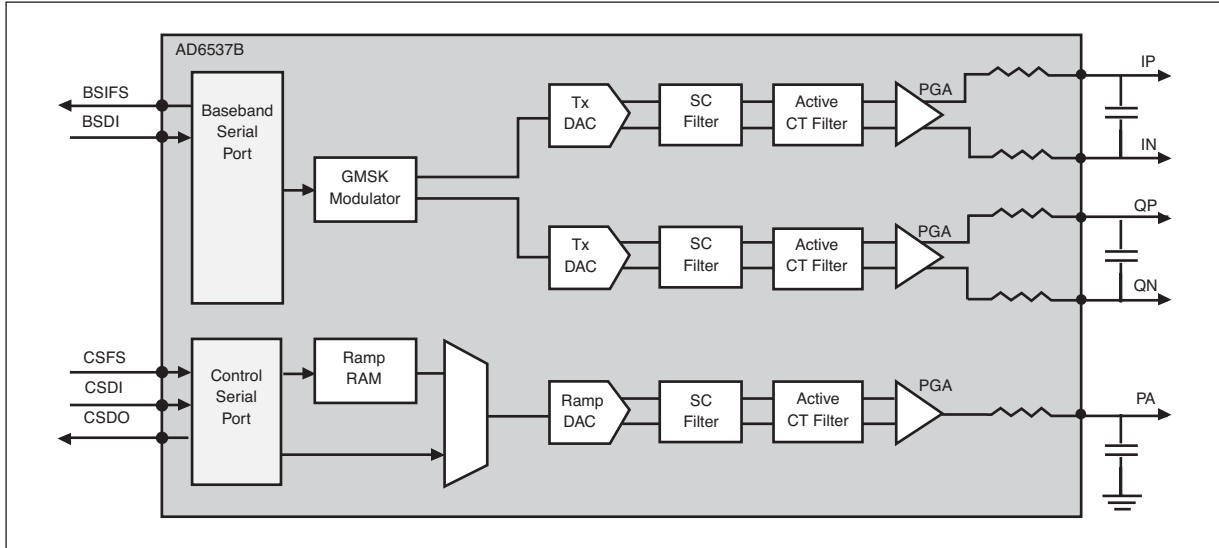

Figure 3-12 AD6537B BASEBAND TRANSMIT SECTION

3.6.2 Baseband Receiver Section

1. This section consists of two identical ADC channels that process baseband in-phase(I) and quadrature(Q) input signals.

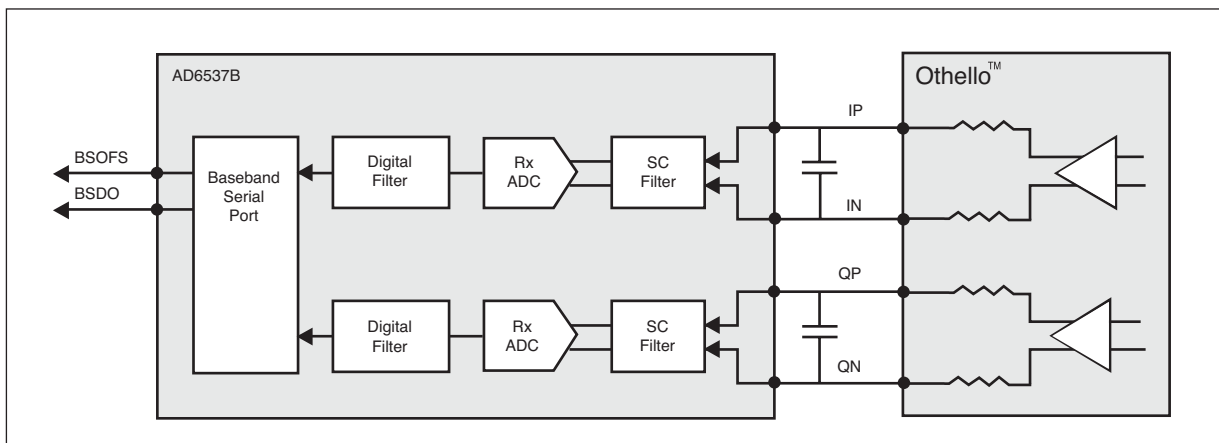

Figure 3-13 AD6537B BASEBAND RECEIVER SECTION

3.6.3 Auxiliary Section

1. This section includes an Automatic Frequency Control(AFC) DAC, voltage reference buffers,an Auxiliary ADC, and light controllers.
 - AFC DAC: 13 bits

2. This section also contains AUX ADC and Voltage Reference
 - IDAC: 10 bits
 - The Auxiliary ADC provides :
 - Two differential inputs for temperature sensing.
 - A differential input for the battery charger current sensor

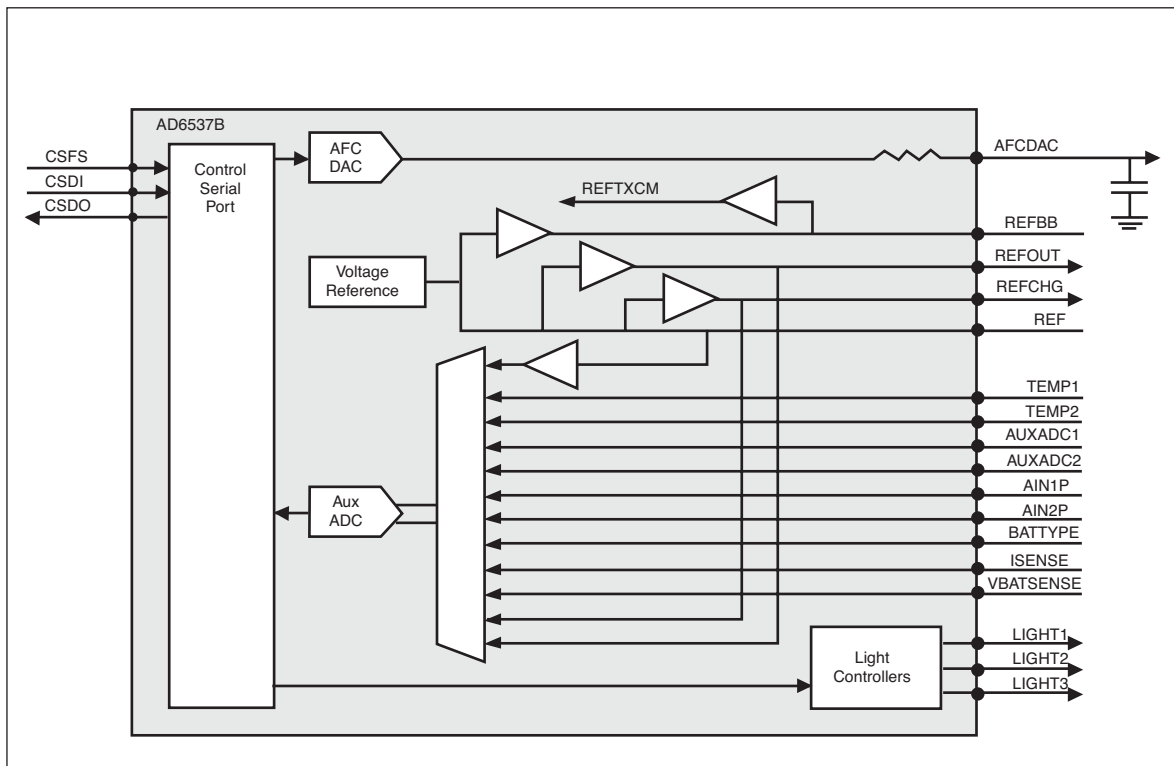

Figure 3-14 AD6537B AUXILIARY SECTION

3.6.4 Audio Section

1. Receive audio signal from microphone. B2070 uses differential configuration.
2. Send audio signal to speaker. B2070 uses differential configuration.
3. This section provides an audio codec with a digital-to-analog converter and an analog-to-digital converter, a ring tone volume controller, a microphone interface, and multiple analog input and output channels.
4. It interconnects with external devices like main microphone, main receiver, and headset. The descriptions of audio port used in B2070 are given below in detail.

<Up Link>

- AIN1P, AIN1N : Main microphone positive/negative terminal
- AIN2P, AIN2N : Headset microphone positive/negative terminal
- AIN3P, AIN3N : External Analog Input terminal

<Down Link>

- AOUT1P, AOUT1N : Main Speaker positive/negative terminal
- AOUT3P : Headset speaker terminal

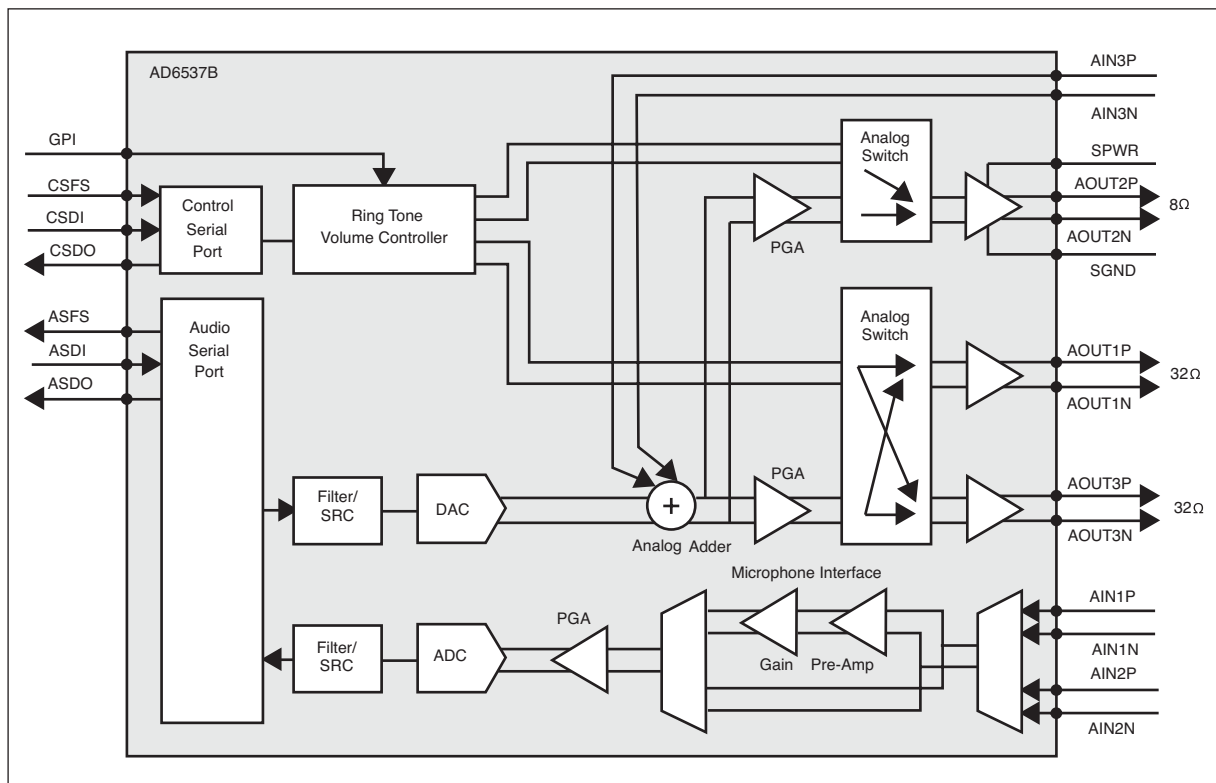

Figure 3-15 AD6537B AUDIO SECTION

3.6.5 Power Management

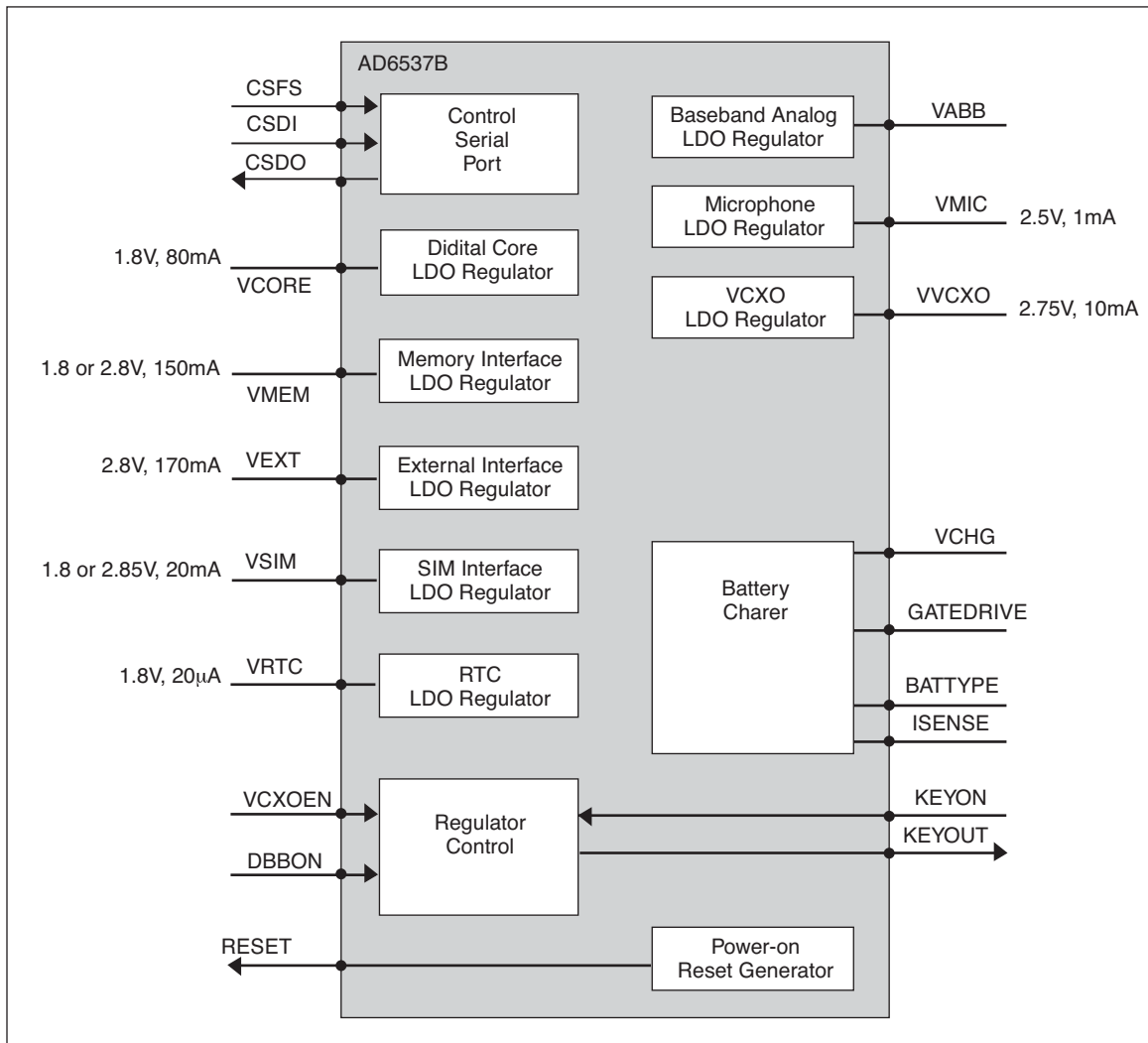

Figure 3-16 AD6537B POWER MANAGEMENT SECTION

1. Power up sequence logic

1. The AD6537B controls power on sequence
2. Power on sequence
 - If a battery is inserted, the battery powers the 8 LDOs.
 - Then if PWRONKEY is detected, the LDOs output turn on.
 - REFOUT is also enabled
 - Reset is generated and send to the AD6527

3. TECHNICAL BRIEF

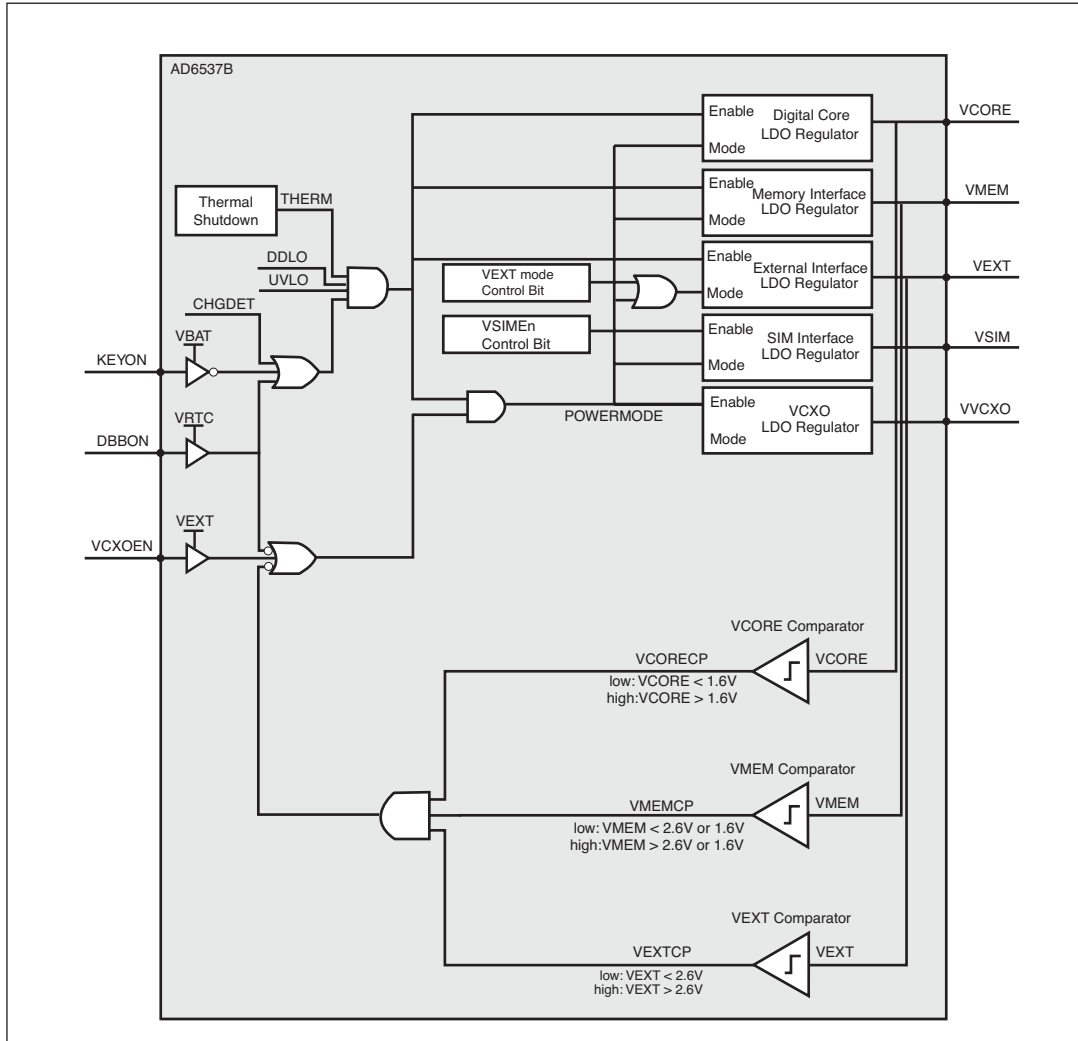

Figure 3-17 AD6537B POWER MODE LOGIC

2. LDO Block

1. There are 8 LDOs in the AD6537B.

- VCORE : supplies Digital baseband Processor core and AD6537B digital core (1.8V, 80mA)
- VMEM : supplies external memory and the interface to the external memory on the digitalbasebandprocessor (1,8V or 2.8V, 150mA)
- VEXT : supplies Radio digital interface and high voltage interface (2.8V, 170mA)
- VSIM : supplies the SIM interface circuitry on the digital processor and SIM card (2.85V, 20mA)
- VRTC : supplies the Real-Time Clock module (1.8 V, 20 μ A)
- VABB : supplies the analog portions of the AD6537B
- VMIC : supplies the microphone interface circuitry (2.5 V, 1 mA)
- VVCCXO : supplies the voltage controlled crystal oscillator (2.75 V, 10 mA)

3. Battery Charging Block

1. It can be used to charge Lithium Ion and/or Nickel Metal Hydride batteries.
Charger initialization, trickle charging, and Li-Ion charging control are implemented in hardware.
2. Charging Process
 - Check charger is inserted or not
 - If AD6537B detects that Charger is inserted, the CC-CV charging starts.
 - Exception : When battery voltage is lower than 3.2V, the precharge (low current charge mode) starts firstly.
 - And the battery voltage reach to 3.2V the CC-CV charging starts.
3. Pins used for charging
 - VCHG : charger supply.
 - GATEDRIVE : charge DAC output
 - ISENSE : charge current sense input
 - VBATSENSE : battery voltage sense input.
 - BATTYPE : battery type identification input
 - REFCHG : voltage reference output
4. TA (Travel Adaptor)
 - Input voltage : AC 85V ~ 260V, 50~60Hz
 - Output voltage : DC 5.2V (0.2 V)
 - Output current : Max 800mA (50mA)
5. Battery
 - Li-ion battery (Max 4.2V, Nom 3.7V)
 - Standard battery: Capacity -830mAh

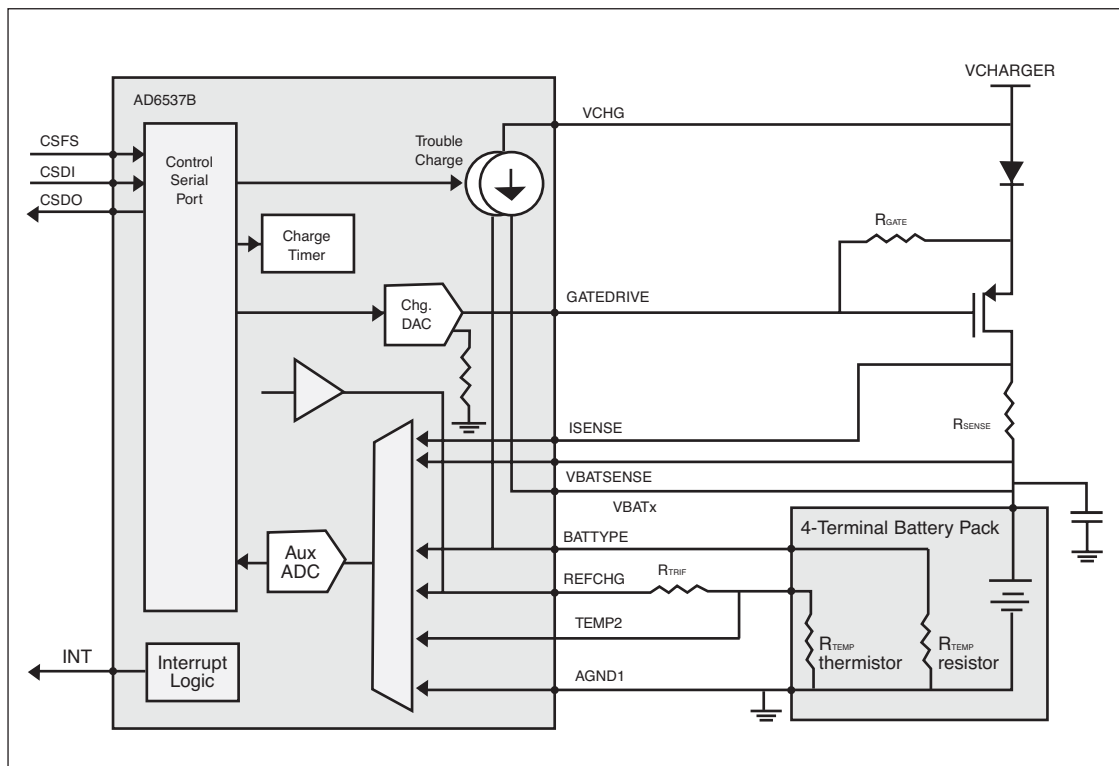

Figure 3-18 AD6537B BATTERY CHARGING BLOCK

3. TECHNICAL BRIEF

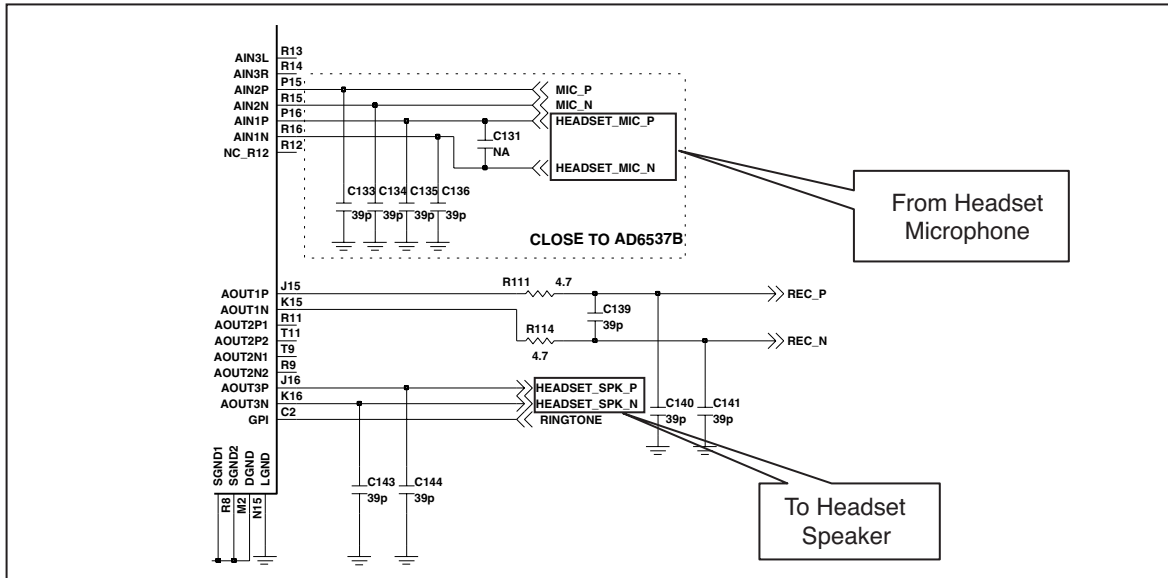

Figure 3-19 B2000 HEADSET SPEAKER/MIC CIRCUIT (AD6537B)

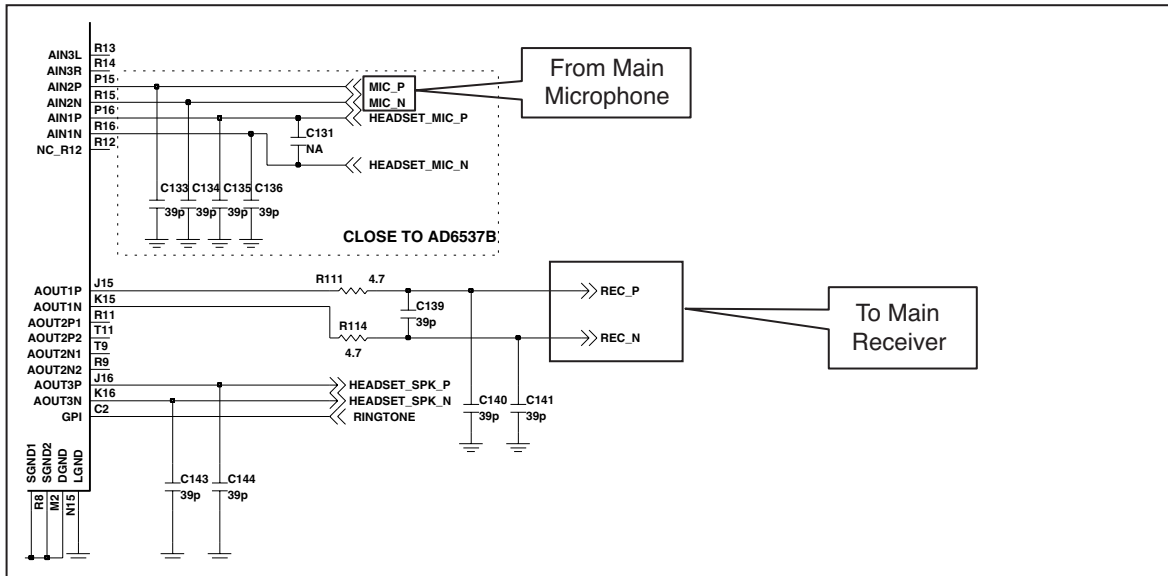

Figure 3-20 B2000 MAIN SPEAKER/MIC CIRCUIT (AD6537B)

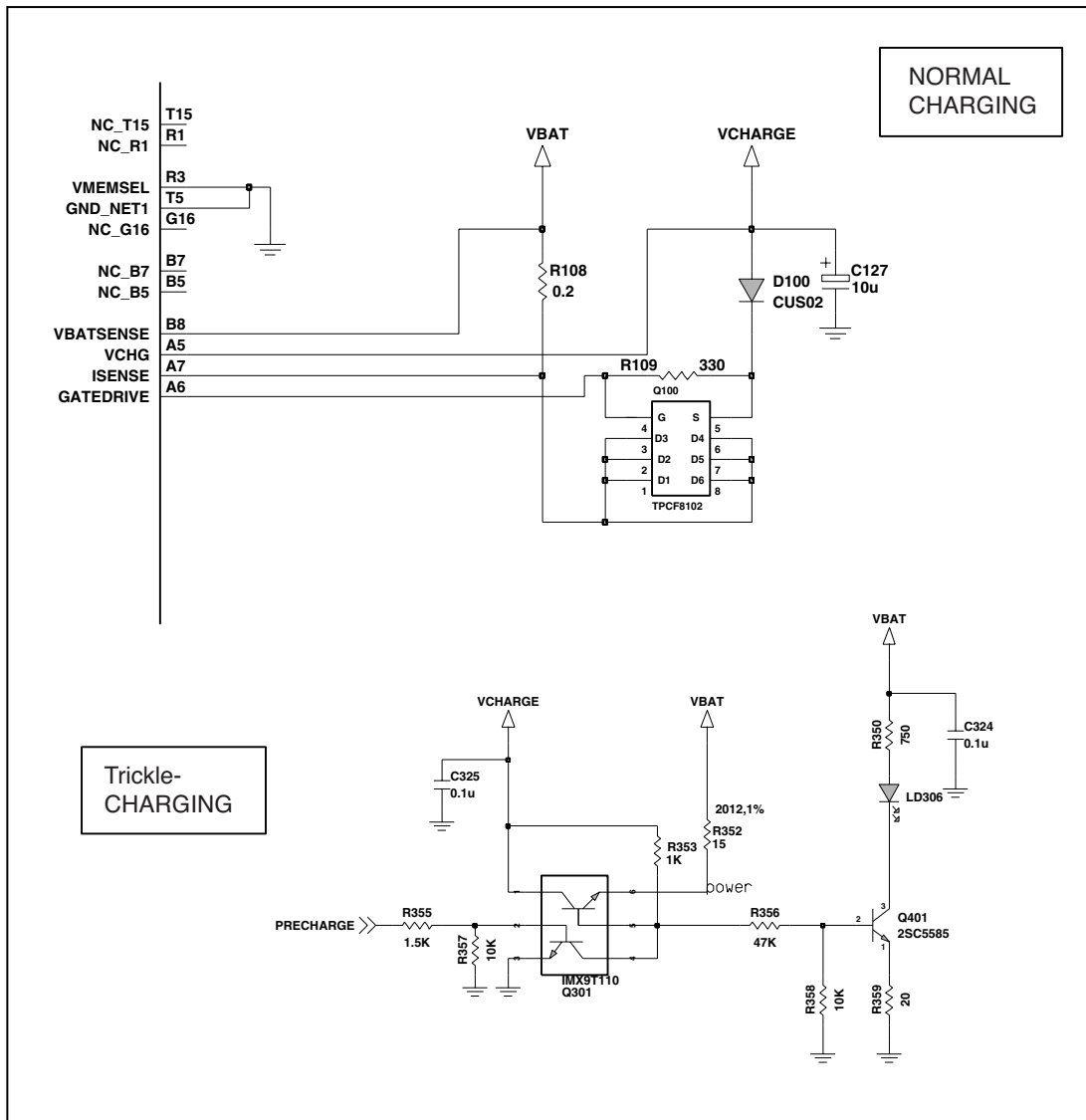

Figure 3-21 CIRCUIT FOR BATTERY CHARGING AT AD6537B

In order to reduce time for trickle charging, additional circuit(Pre-charge circuit) was included. This circuit has supplied Max 160mA current into the battery additionally. So call it, it reduce trickle charging time

3.7 Display and Interface

• LCD

Properties	Spec.	Unit
Active Screen Size	28.022(H) X 28.022(V)	mm
Color Depth	65,000	colors
Resolution	128 X RGB X 128	dots
Pixel Size	0.063(H) X 0.209(V)	mm

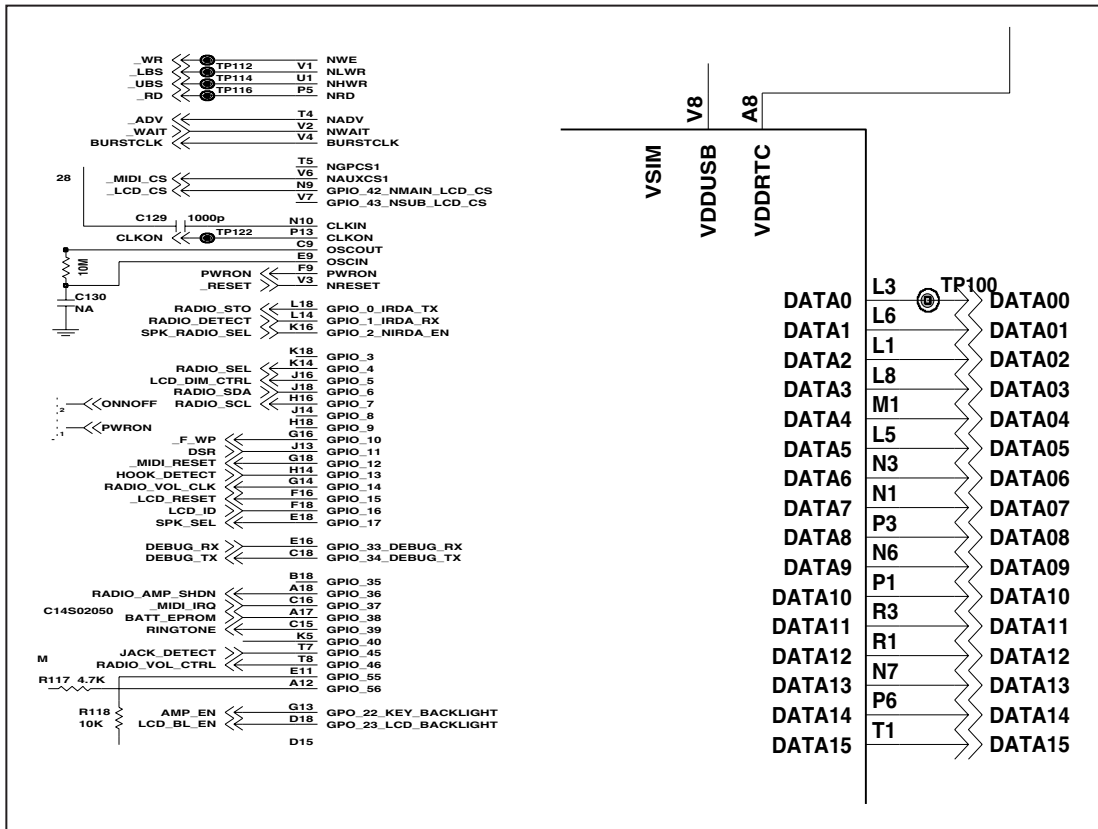

Controlled by _LCD_CS, LCD_RESET, _WR, DATA[00:15], LCD_ID,

- _LCD_CS : MAIN LCD driver chip enable. MAIN LCD driver IC has own CS pin
- LCD_RESET : This pin resets LCD module. This signal comes from DBB directly.
- _WR : Write control Signal
- _DATA[00:15] : Parallel data lines.
- LCD_ID[1:2] : LCD type selection signals
- LCD_ID1 : LCD maker (2.4V is SII, 0V is HyeLCD)
- LCD_ID[2:3] : for the future using
- Forusing 65K color, data buses should be 16 bits.

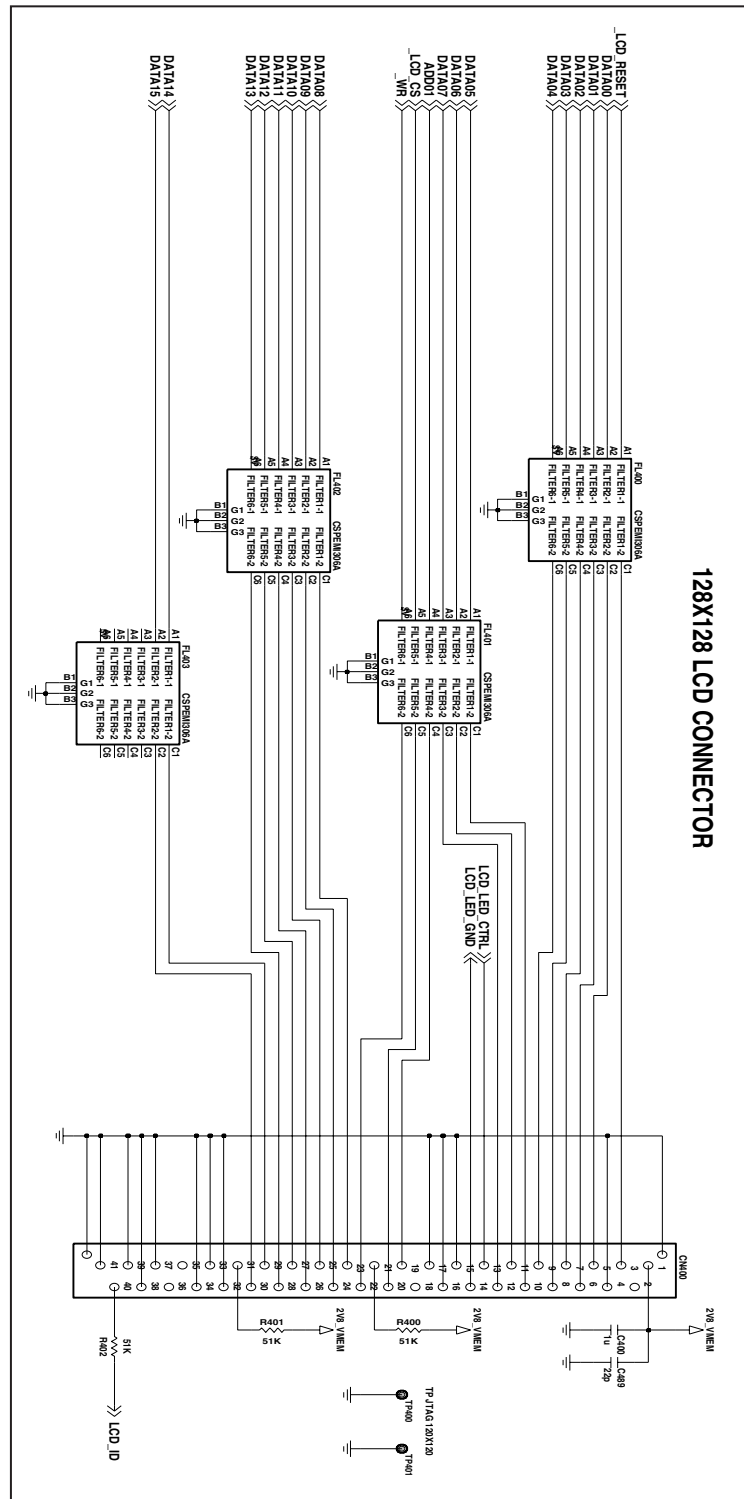

Figure 3-22 LCD INTERFACE CIRCUIT

3. TECHNICAL BRIEF

3.8 Radio Interface

B2070 has a built-in FM Radio. FM Radio Uses Ear Mic as the Antenna.

IC for FM Radio is Niigata NS953. B2070 can produce FM Radio Sound Both through Speaker and Ear Mic.

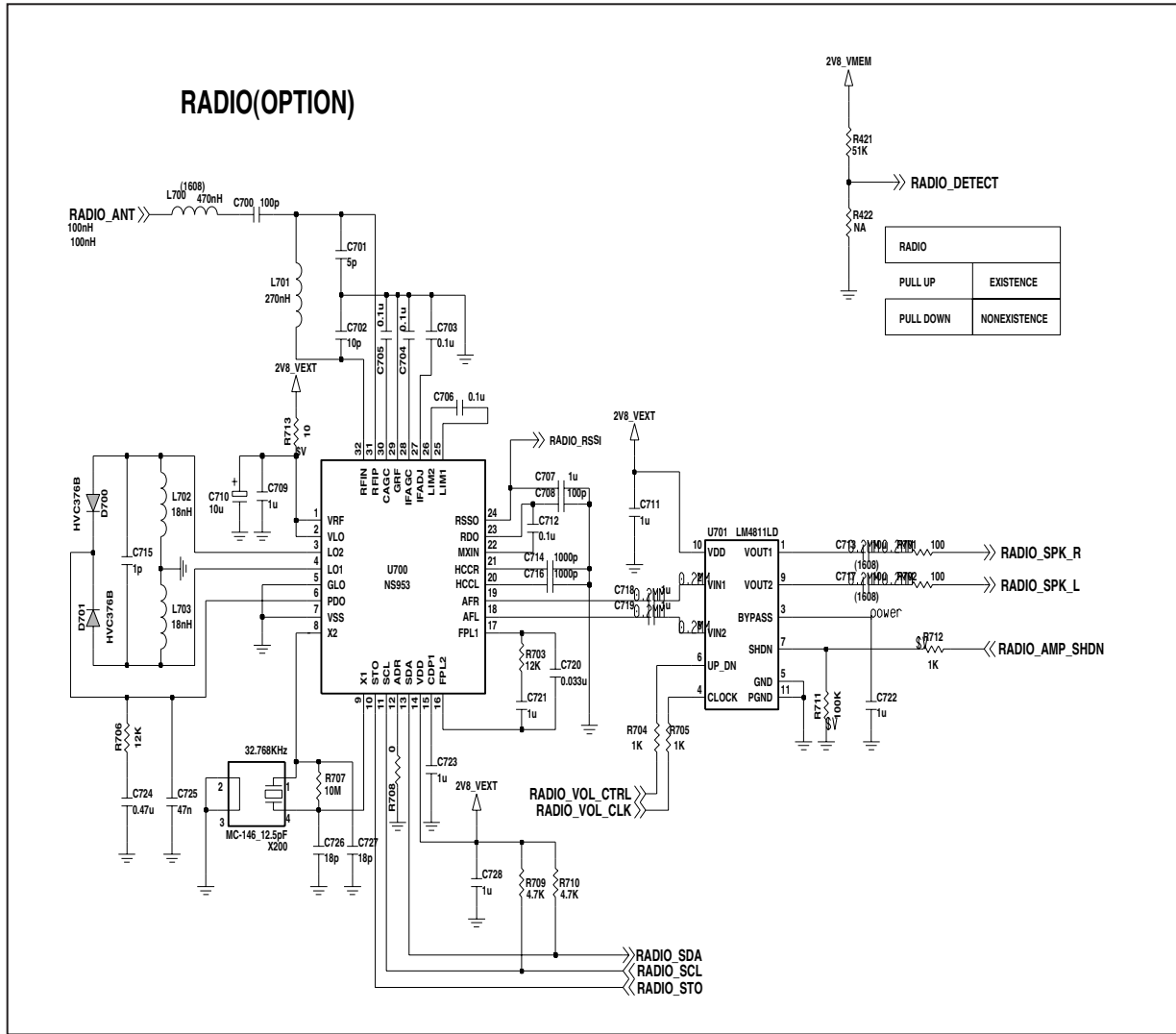

Figure 3-23 Radio Circuit

3.9 Keypad Switches and Scanning

The key switches are metal domes, which make contact between two concentric pads on the keypad layer of the PCB when pressed. There are 21 switches (Normal Key 21EA, No sidekey), connected in a matrix of 5 rows by 5 columns and additional GPIO 35 for KEY_ROW5, as shown in Figure 3-24, except for the power switch, which is connected independently. Functions, the row and column lines of the keypad are connected to ports of AD6527. The columns are outputs, while the rows are inputs and have pull-up resistors built in. When a key is pressed, the corresponding row and column are connected together, causing the row input to go low and generate an interrupt. The columns/rows are then scanned by AD6527 to identify the pressed key.

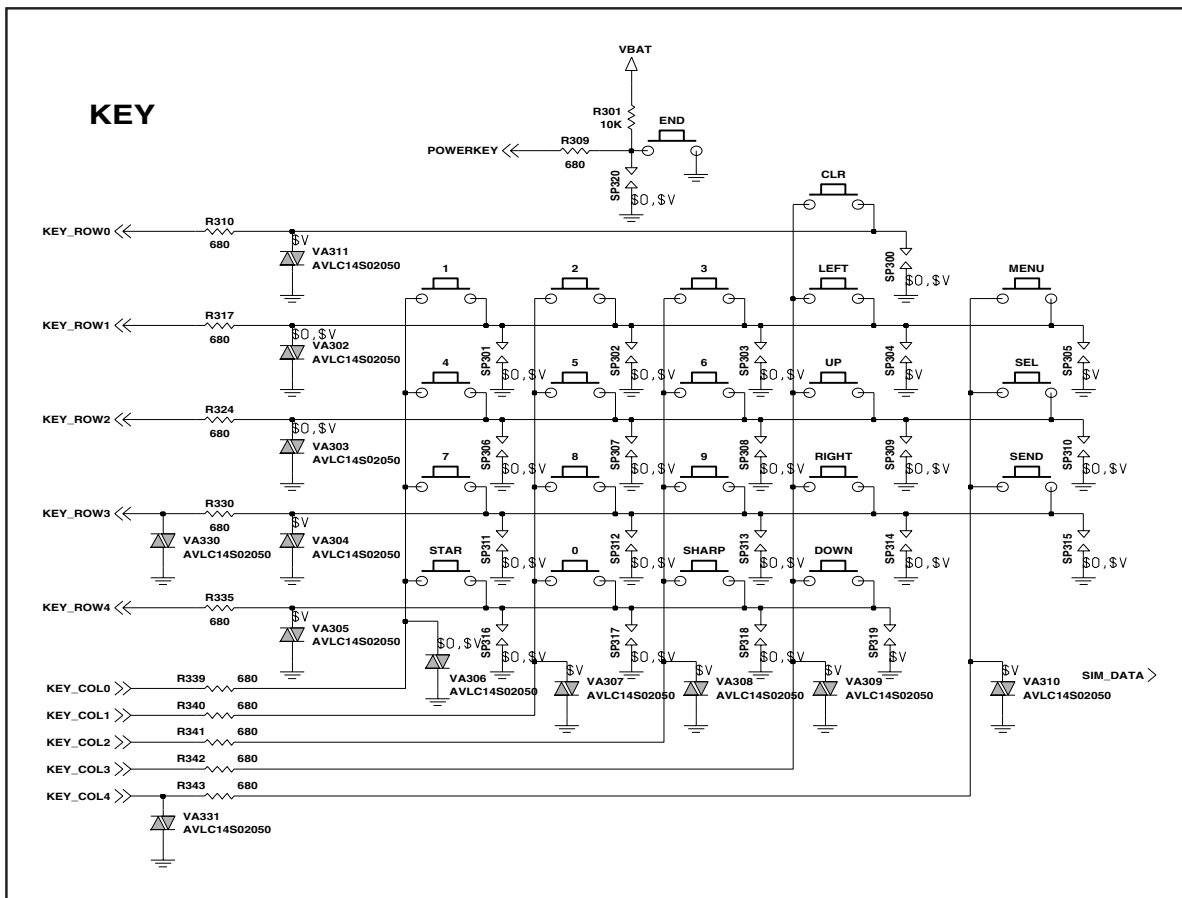

Figure 3-24 Keypad Switches and Scanning

3.10 Microphone

The microphone is placed to the front cover and contacted to main PCB. The audio signal is passed to AIN2P and AIN2N pins of AD6535. The voltage supply VMIC is output from AD6537B, and is a biased voltage for the AIN2P. The AIN2P and AIN2N signals are then A/D converted by the voiceband ADC part of AD6537B. The digitized speech (PCM 8KHz ,16KHz) is then passed to the DSP section of AD6527 for processing (coding, interleaving etc).

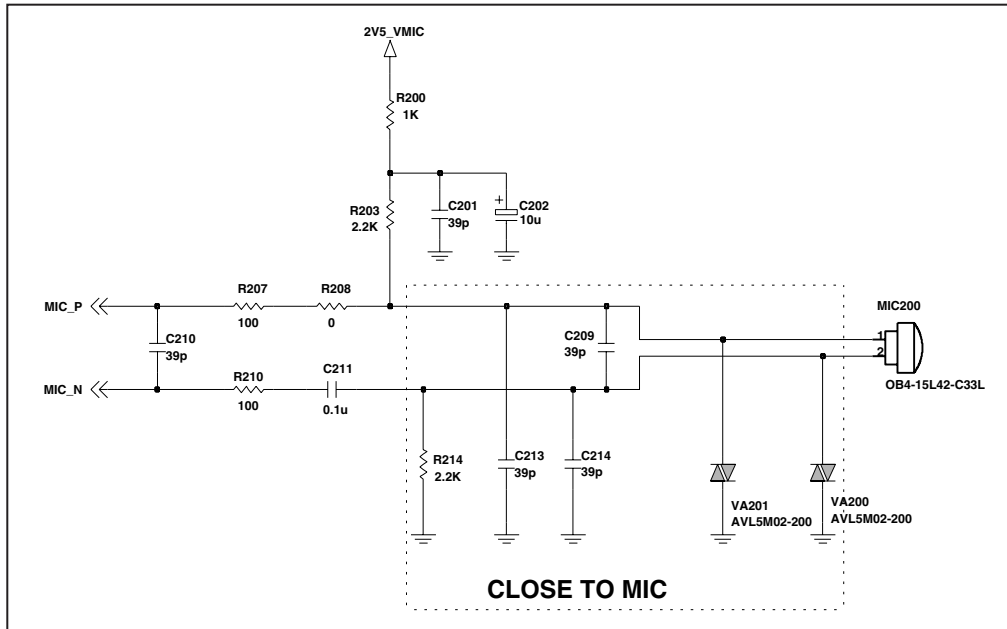
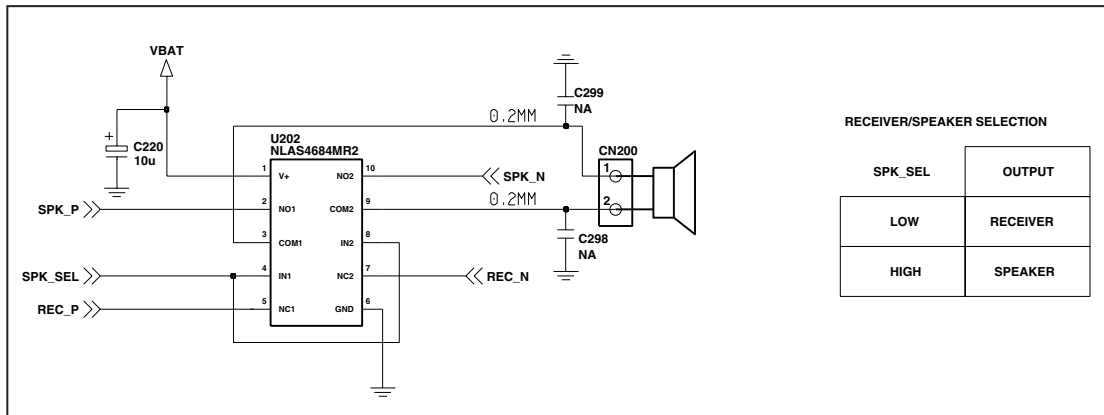

Figure 3-25 Connection between Microphone and AD6537B

3.11 Main Speaker

In the case of B2070, The main speaker is driven directly from AD6537B AOUT1P and AOUT1N pins and the gain is controlled by the PGA in an AD6537B.



3.12 Headset Interface

This phone chooses a 5 pin type headset which has 6 electrodes such as HEADSET_SPK_OUT_P, HEADSET_MIC_P, JACK_DETECT, HEADSET_SPK_OUT_N, RADIO_ANT

This type supports stereo sound

Switching from Receiver to Headset Jack

If jack is inserted, JACK_DETECT goes from high to low.
Audio path is switched from receiver to earphone by JACK_DETECT interrupt.

Switching from Headset Jack to Receiver

If jack is removed, JACK_DETECT goes from low to high.
Audio path is switched from earphone to receiver by JACK_DETECT interrupt.

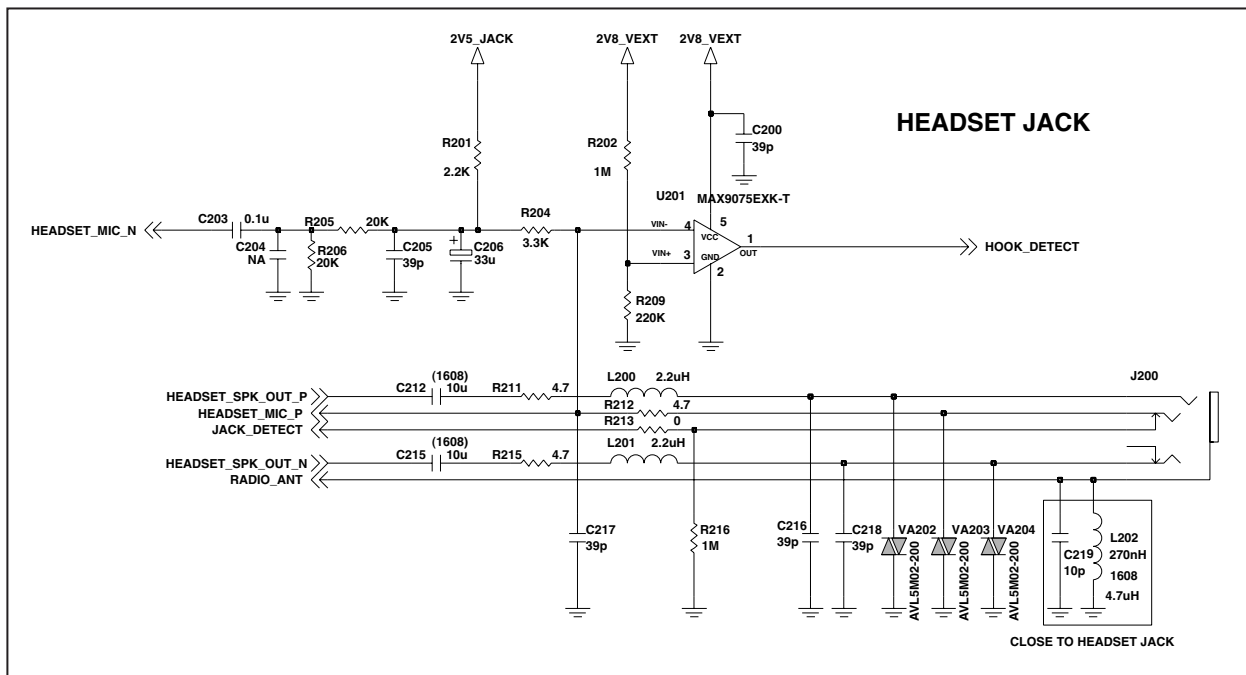

Figure 3-26 HEADSET JACK INTERFACE

3.13 Key Back-light Illumination

In key back-light illumination, there are 6 Blue LEDs in Main Board, which are driven by MIDI_KEY_BL1 and MIDI_KEY_BL2 signal from ML2871HB.

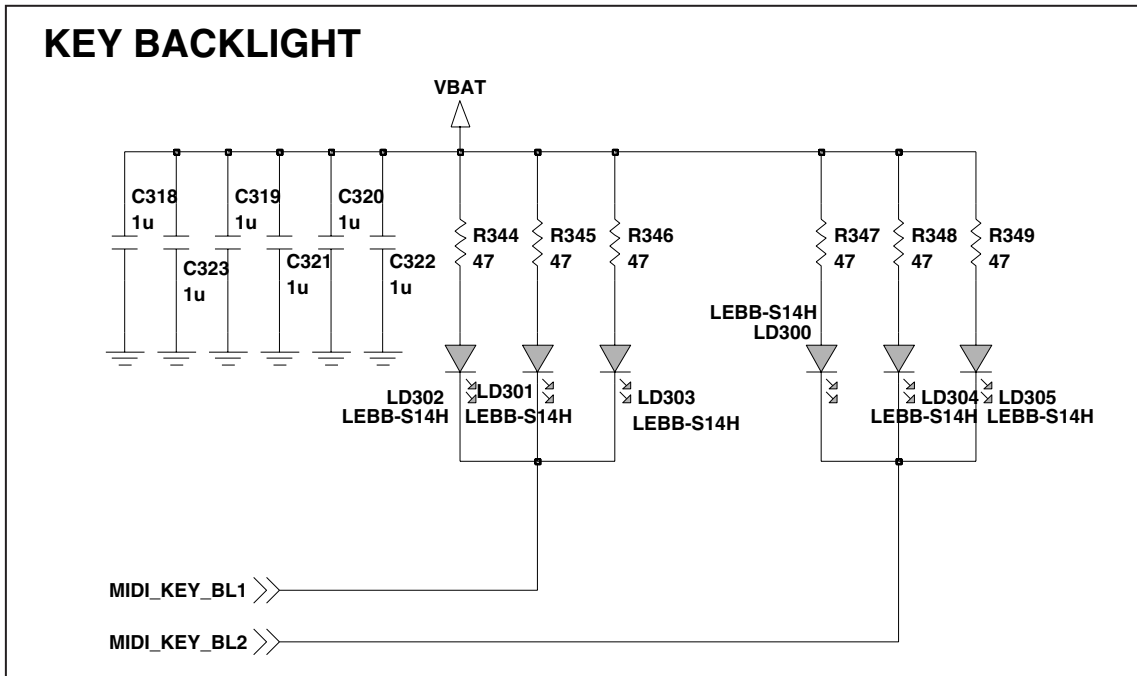

Figure 3-27 KEY BACK-LIGHT ILLUMINTION

3.14 VIBRATOR

The vibrator is placed in the folder cover and contacted to LCD MODULE.
The vibrator is driven from MIDI_VIBRATOR from ML2871HB.

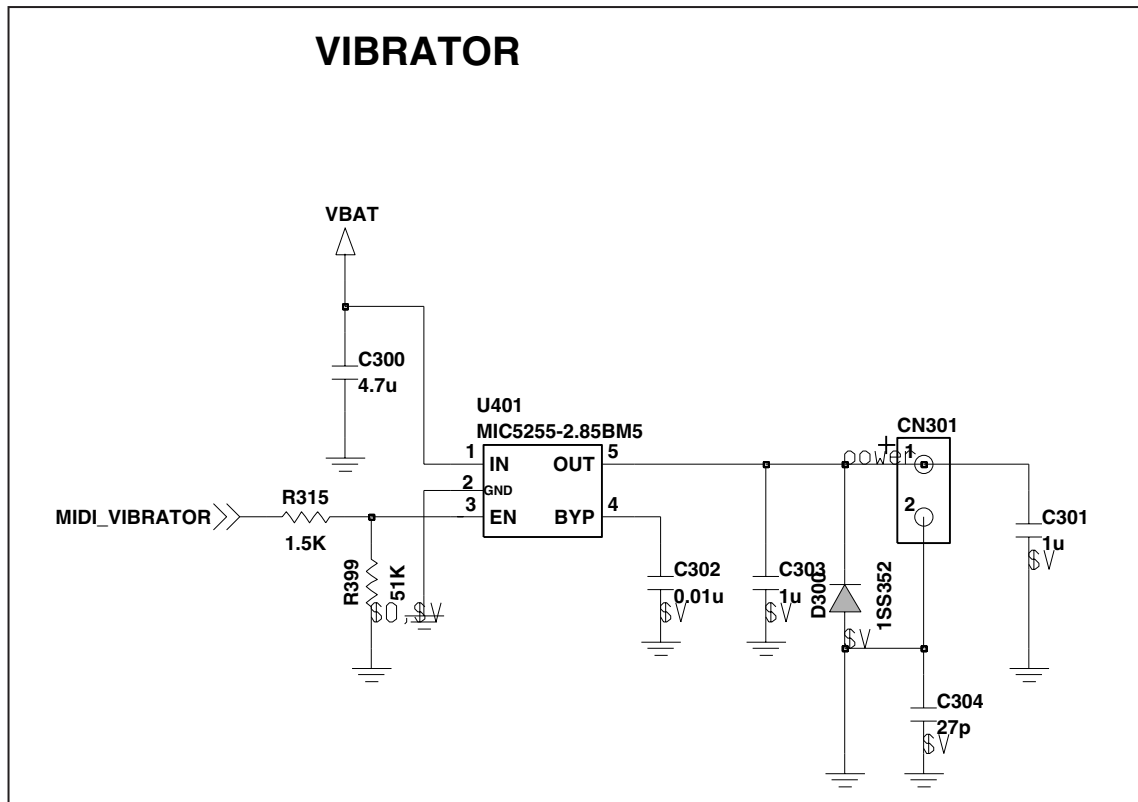

Figure 3-28 MOTOR

4. TROUBLE SHOOTING

4.1 RX Trouble

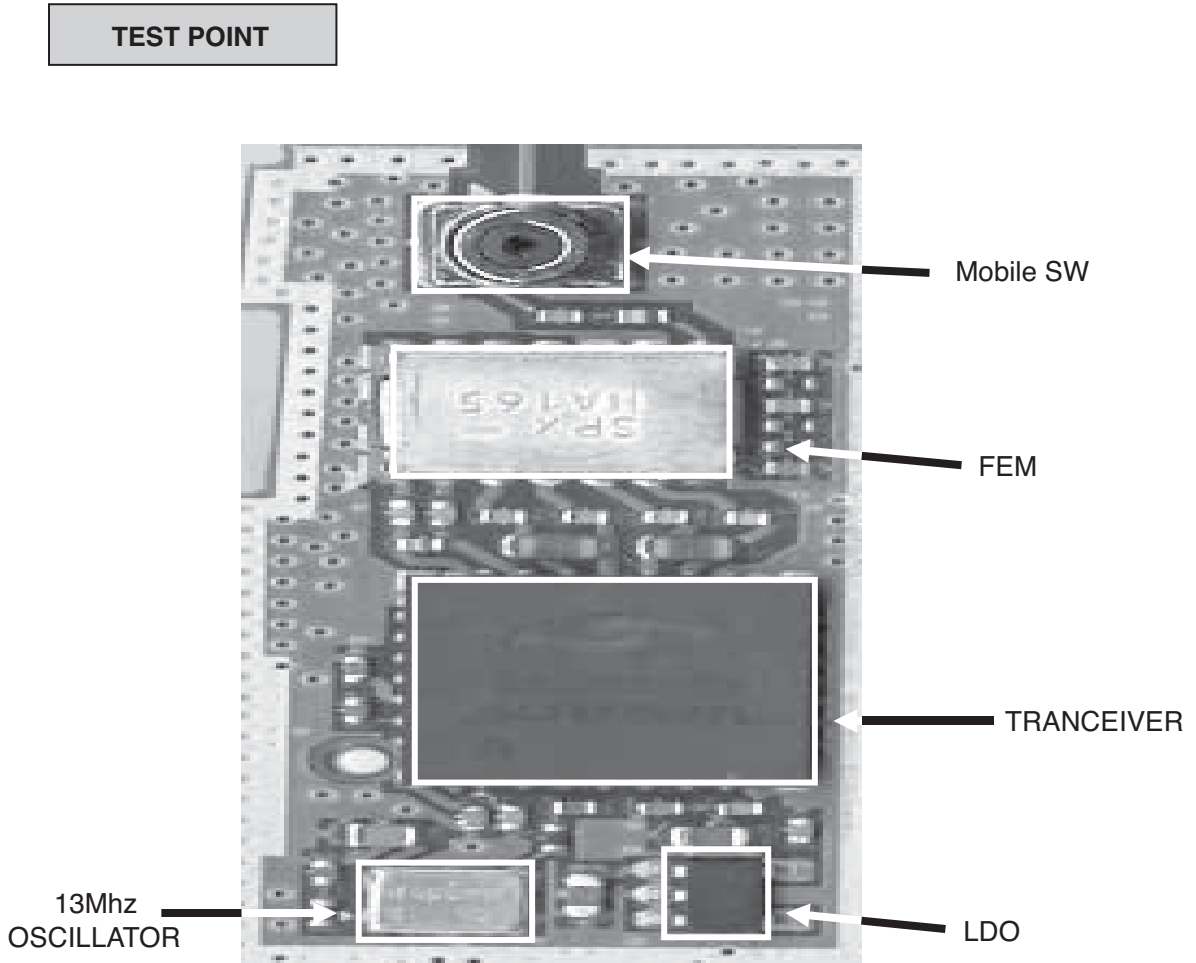
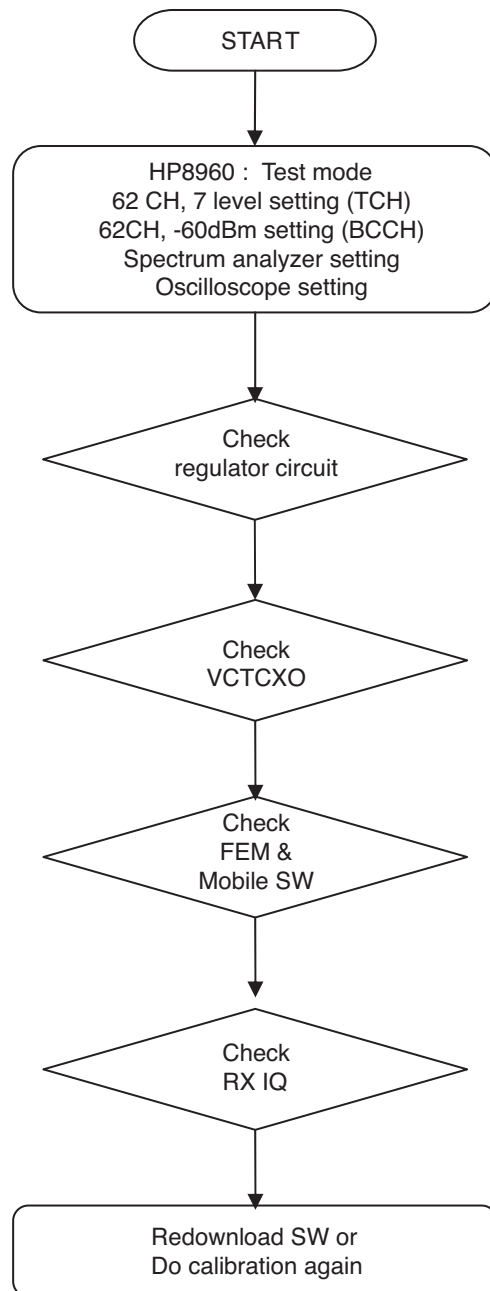

Figure 4-1(a)

Checking Flow



(1) Checking Regulator Circuit

TEST POINT

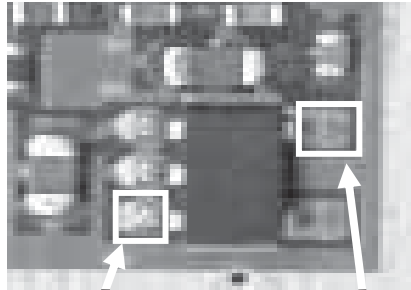

CIRCUIT

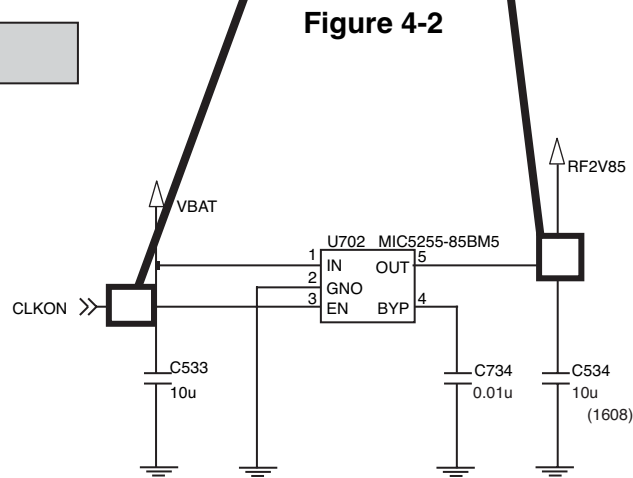

Checking Flow

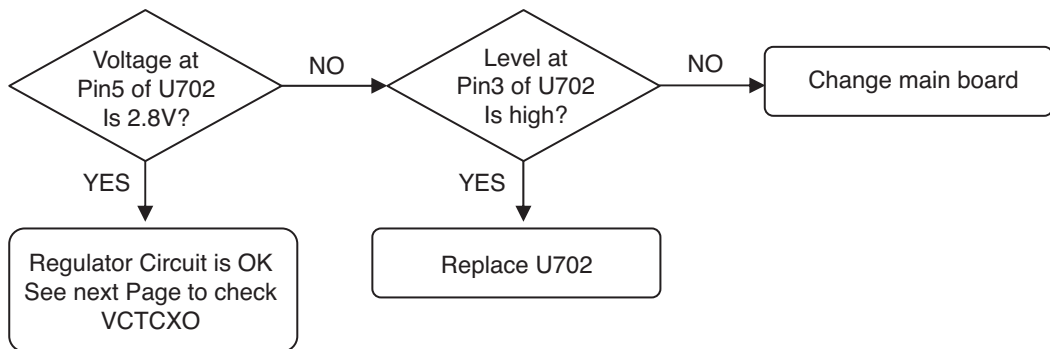

(2) Checking VCTCXO Circuit

TEST POINT

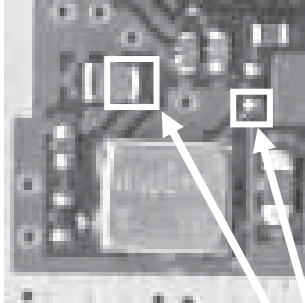

Checking Flow

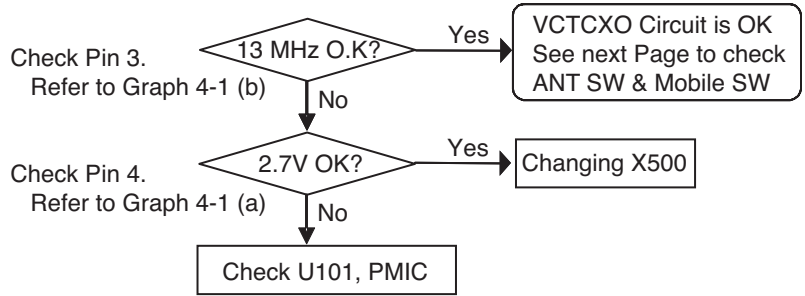

CIRCUIT

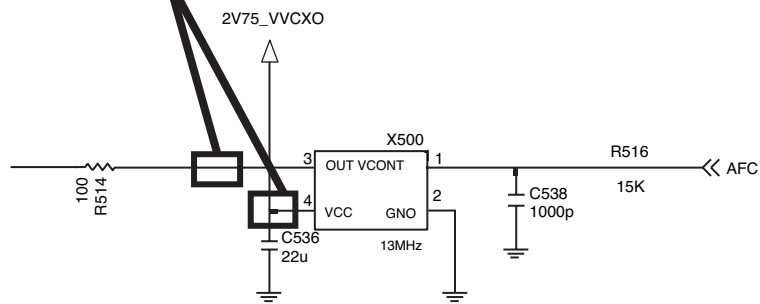

Waveform

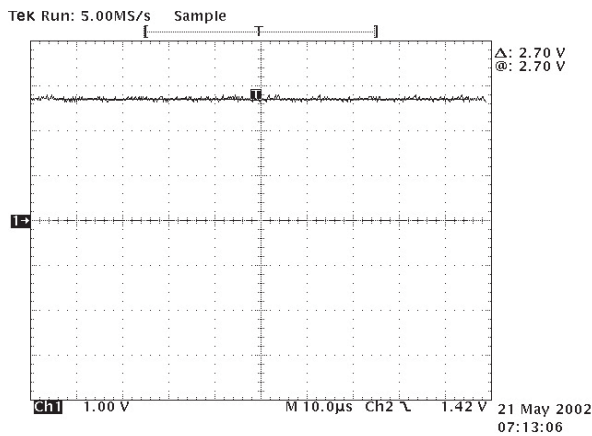

Graph 4-1(a)

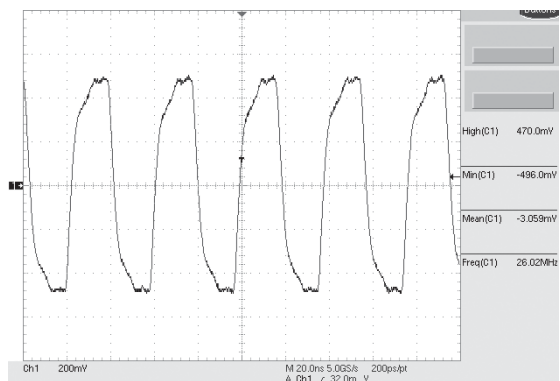

Graph 4-1(b)

(3) Checking FEM & Mobile SW

TEST POINT

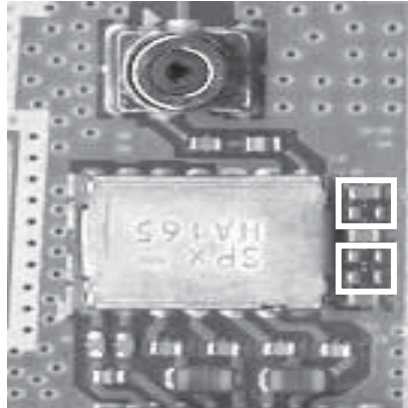

CIRCUIT

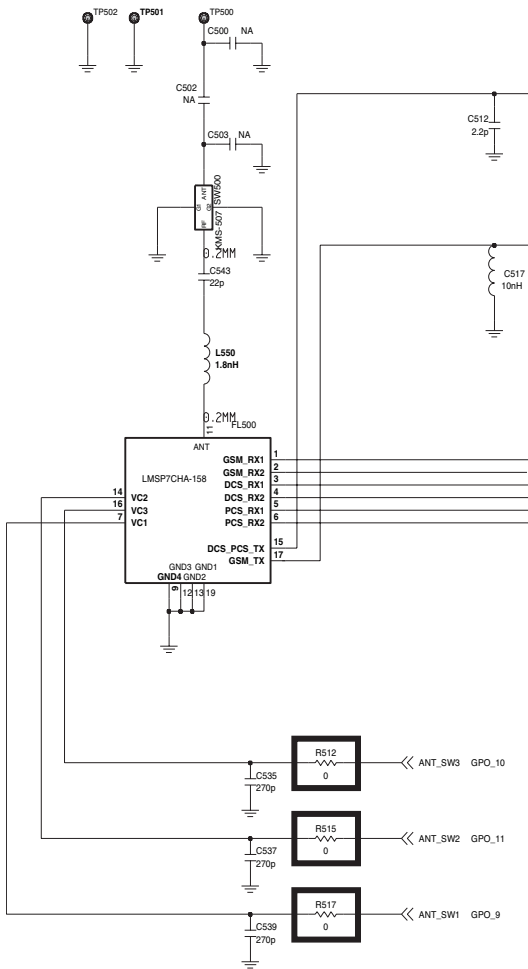
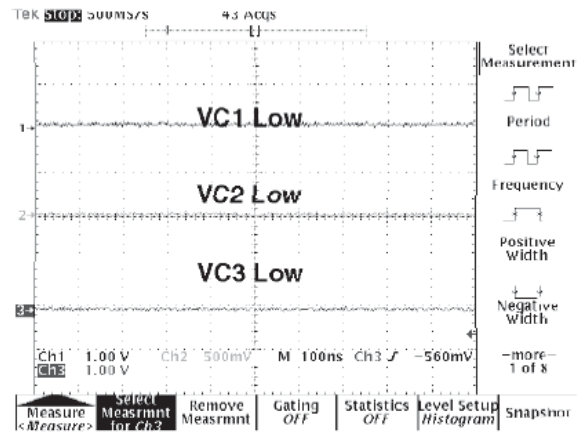
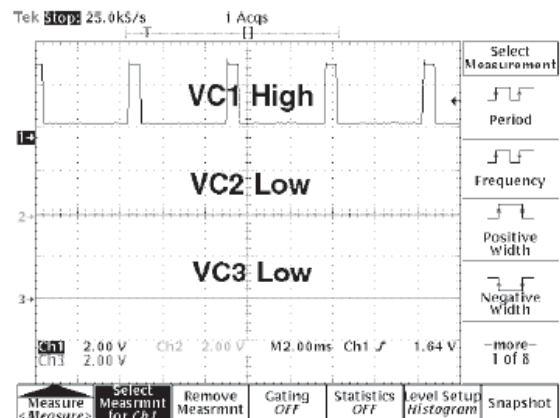

Figure 4-5

Waveform



FEM Control GSM & DCS
Graph 4-3(a)



FEM Control PCS
Graph 4-3(b)

Checking Flow

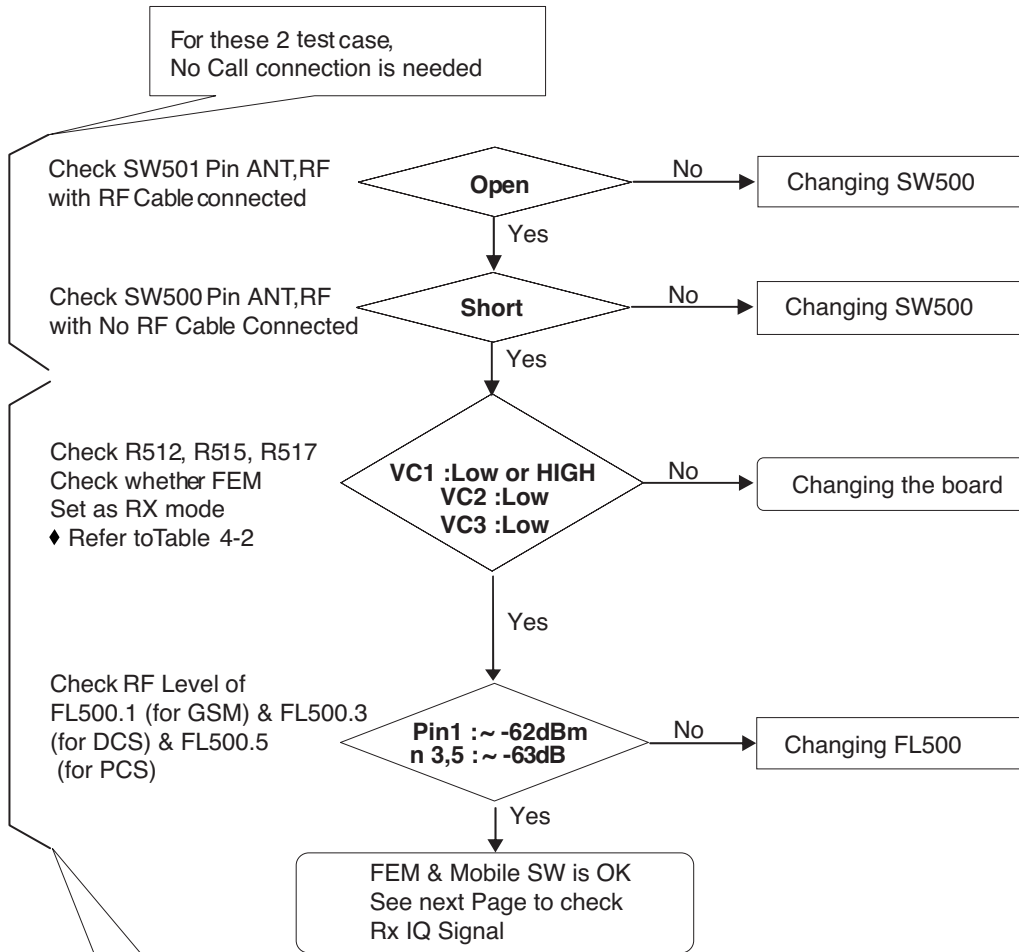

For this RF Level test case,
RX Stand alone Mode is needed
refer to chapter 11

ANT SW CONTROL TABLE

ANT SW	VC1	VC2	VC3
EGSM_Tx	L	L	H
DCS PCS_Tx	L	H	L
EGSM DCS_ Rx	L	L	L
PCS_Rx	H	L	L

Table 4-2

(4) Checking RX IQ

TEST POINT

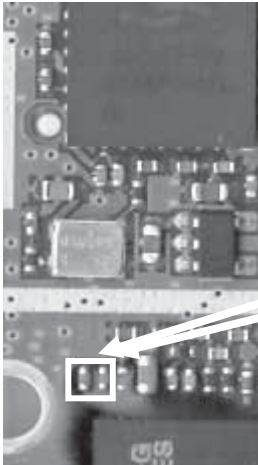

CIRCUIT

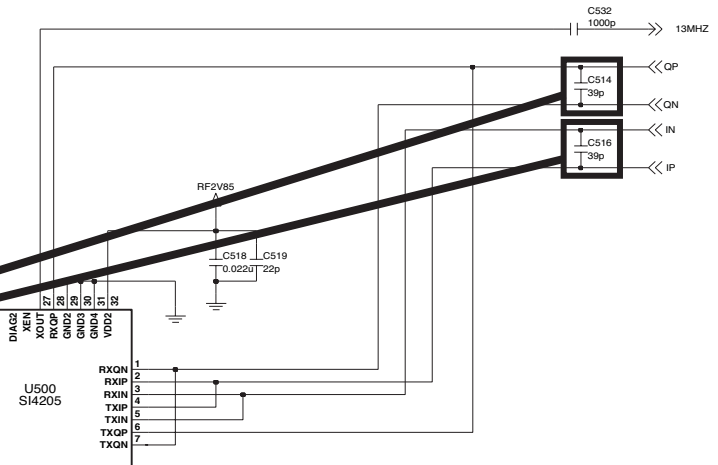

Waveform

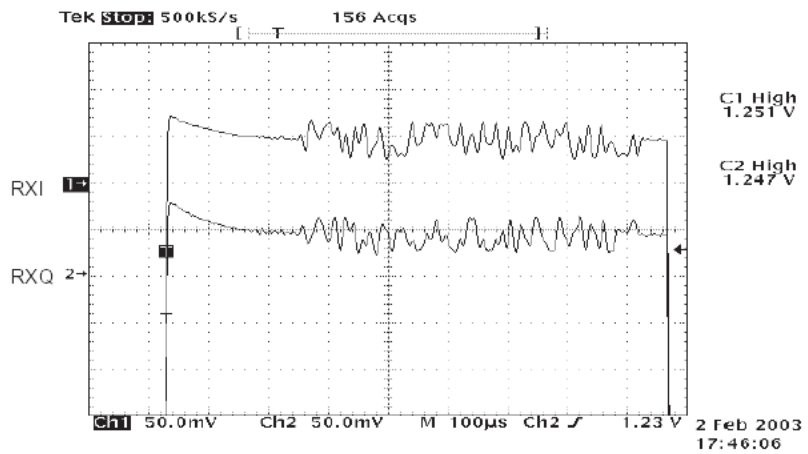

Graph 4-4

Checking Flow

Check C514, C516.
Check if there is
Any Major Difference
♦ Refer to Graph 4-4

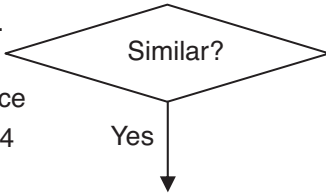

Replace U500

Redownload software and calibration againg

4.2 TX Trouble

TEST POINT

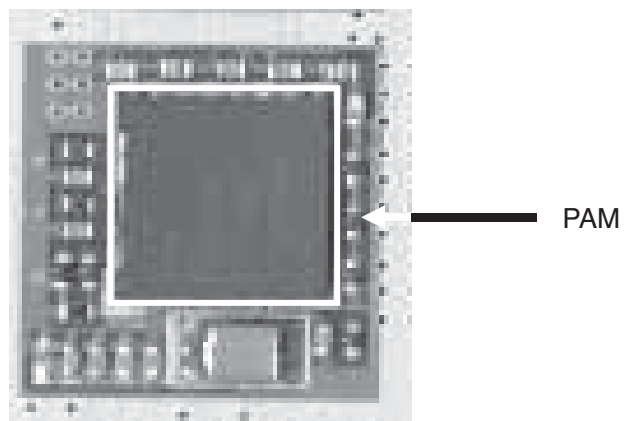
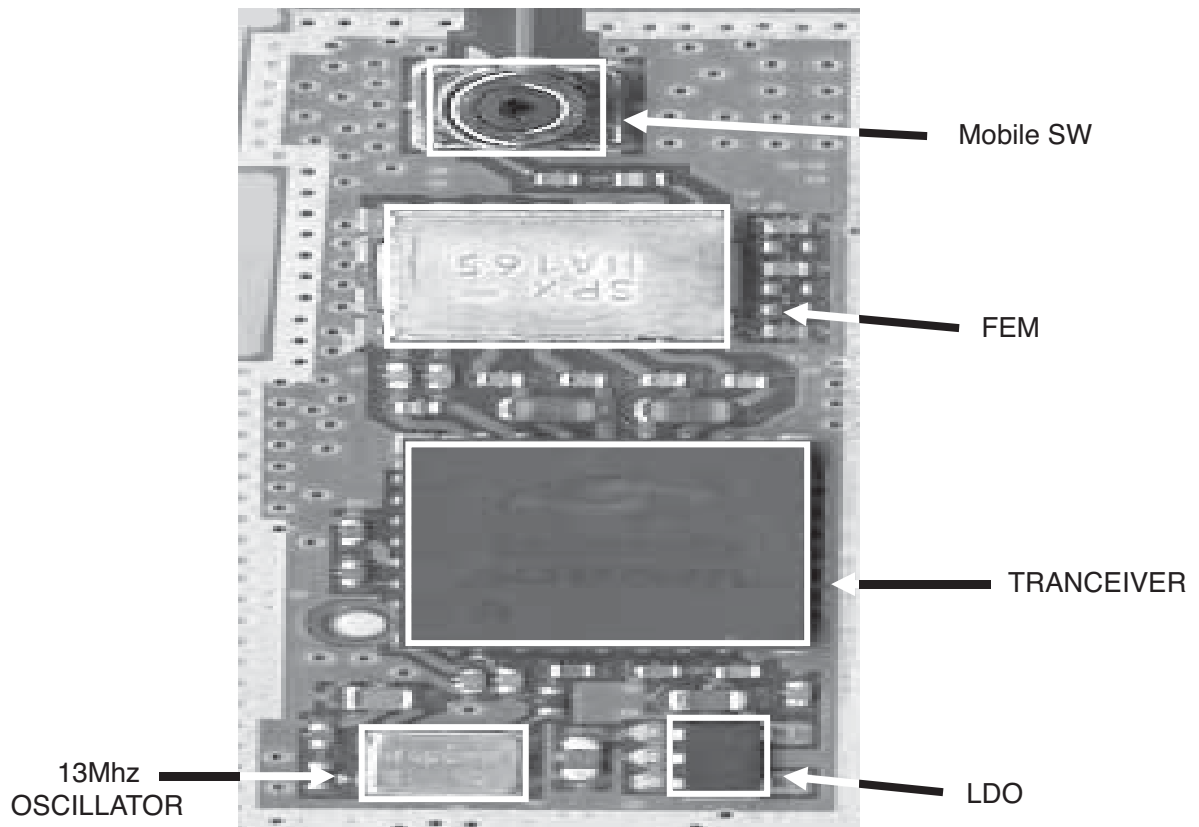

4 . TROUBLE SHOOTING

Checking Flow

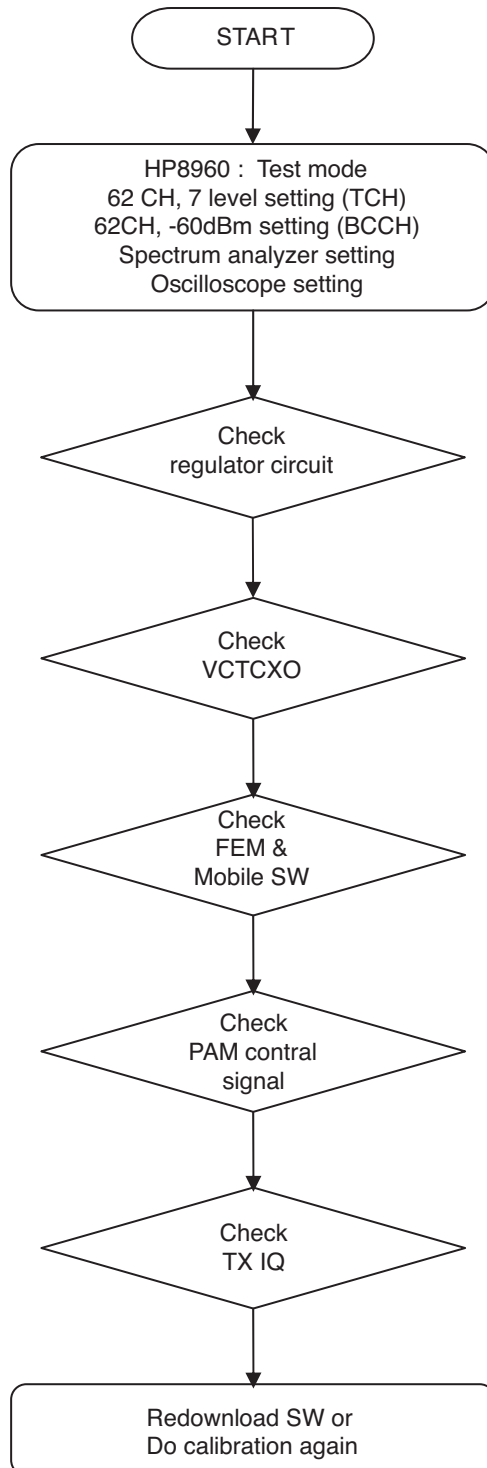

(1) Checking Regulator Circuit

TEST POINT

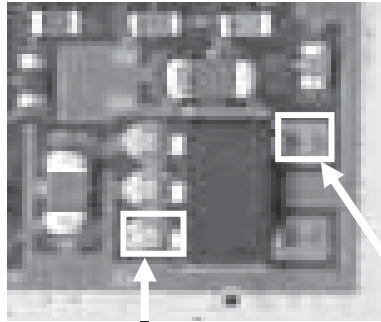

CIRCUIT

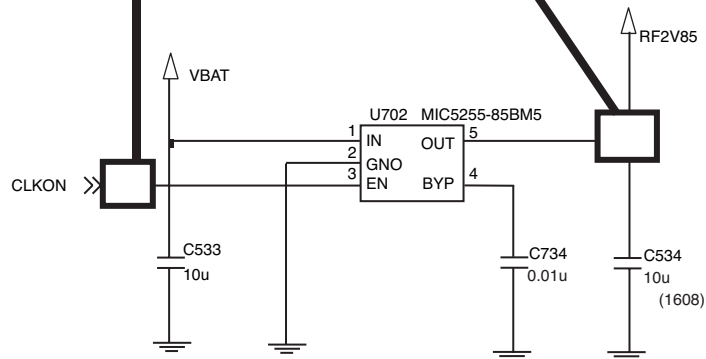

Checking Flow

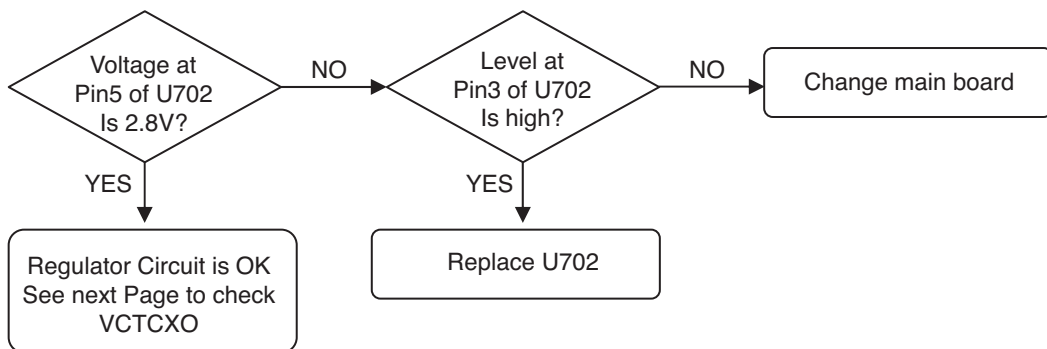

(2) Checking VCTCXO Circuit

TEST POINT

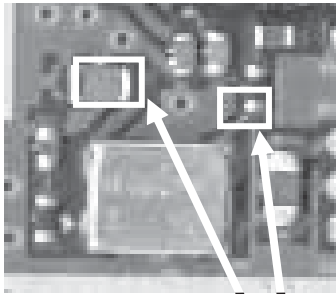

Checking Flow

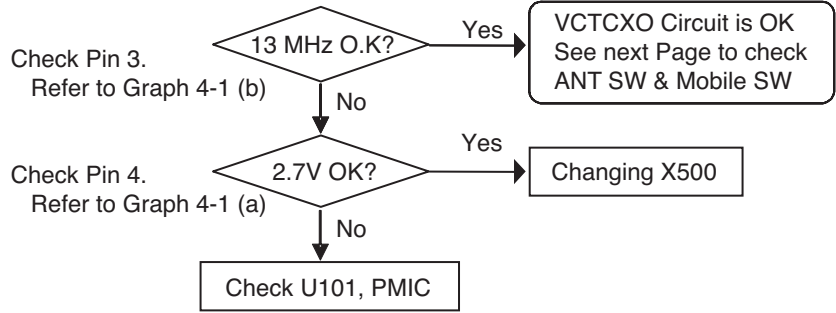

CIRCUIT

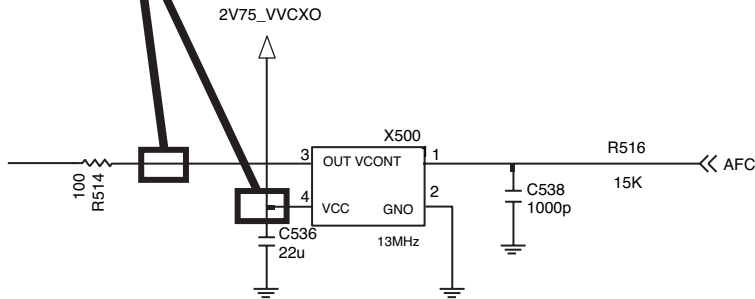

Waveform

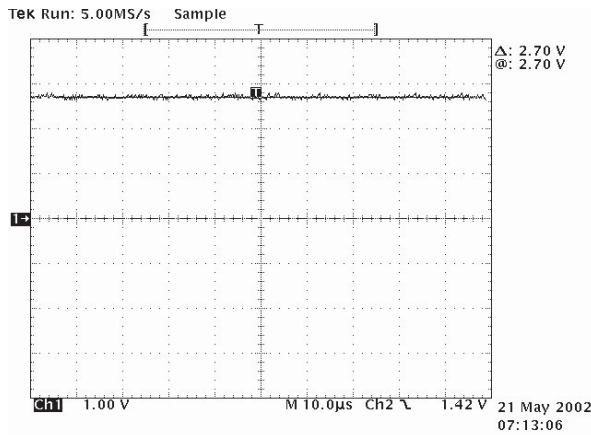

Graph 4-1(a)

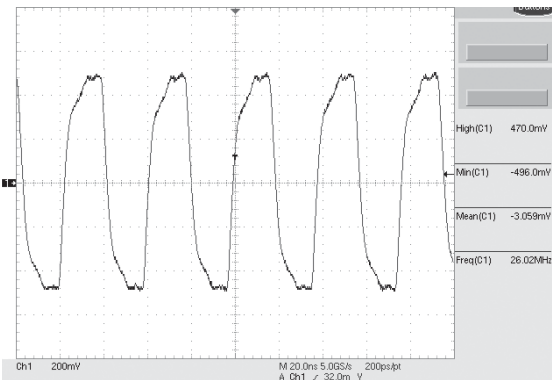

Graph 4-1(b)

(3) Checking Ant SW & Mobile SW

TEST POINT

CIRCUIT

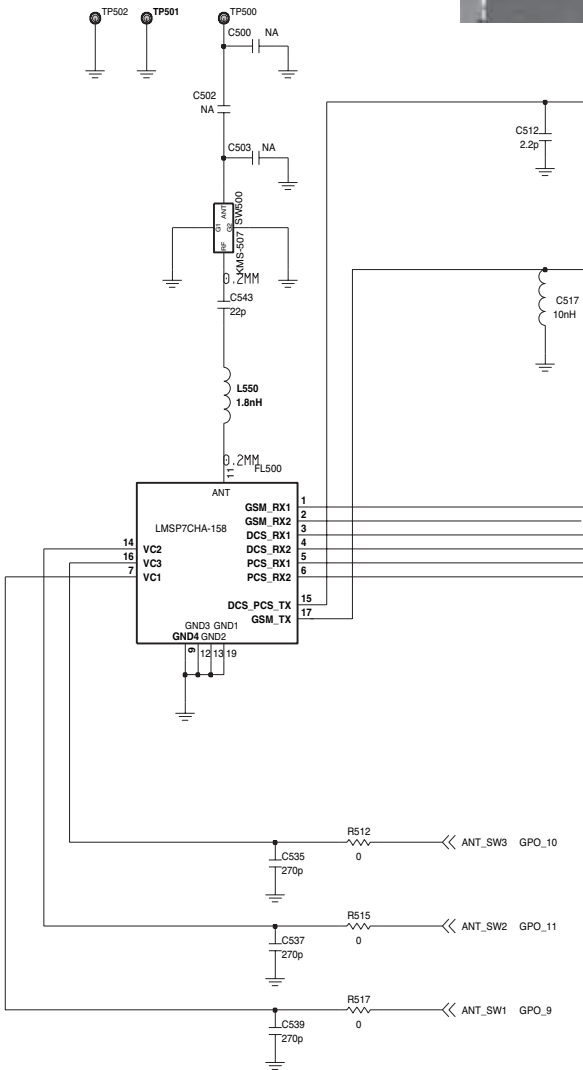
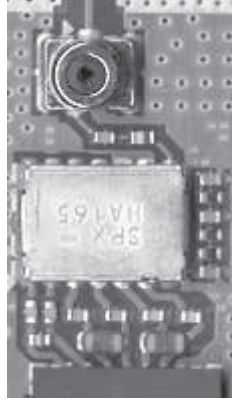
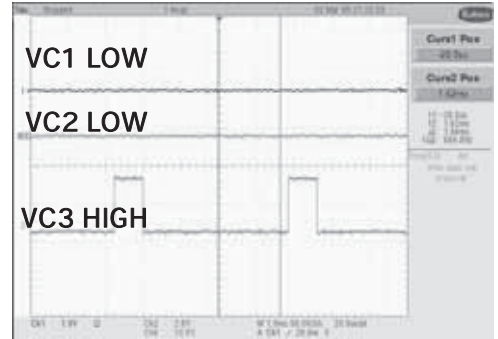
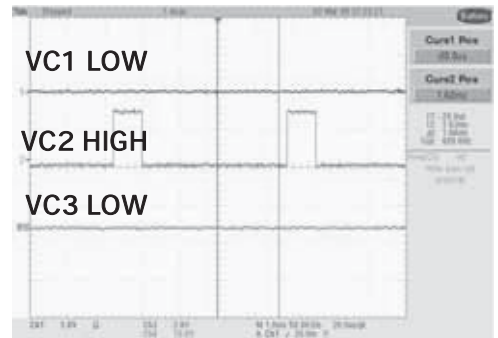

Figure 4-5

Waveform



FEM Control EGSM
Graph 4-6(a)



FEM Control DCS & PCS
Graph 4-6(b)

4 . TROUBLE SHOOTING

Checking Flow

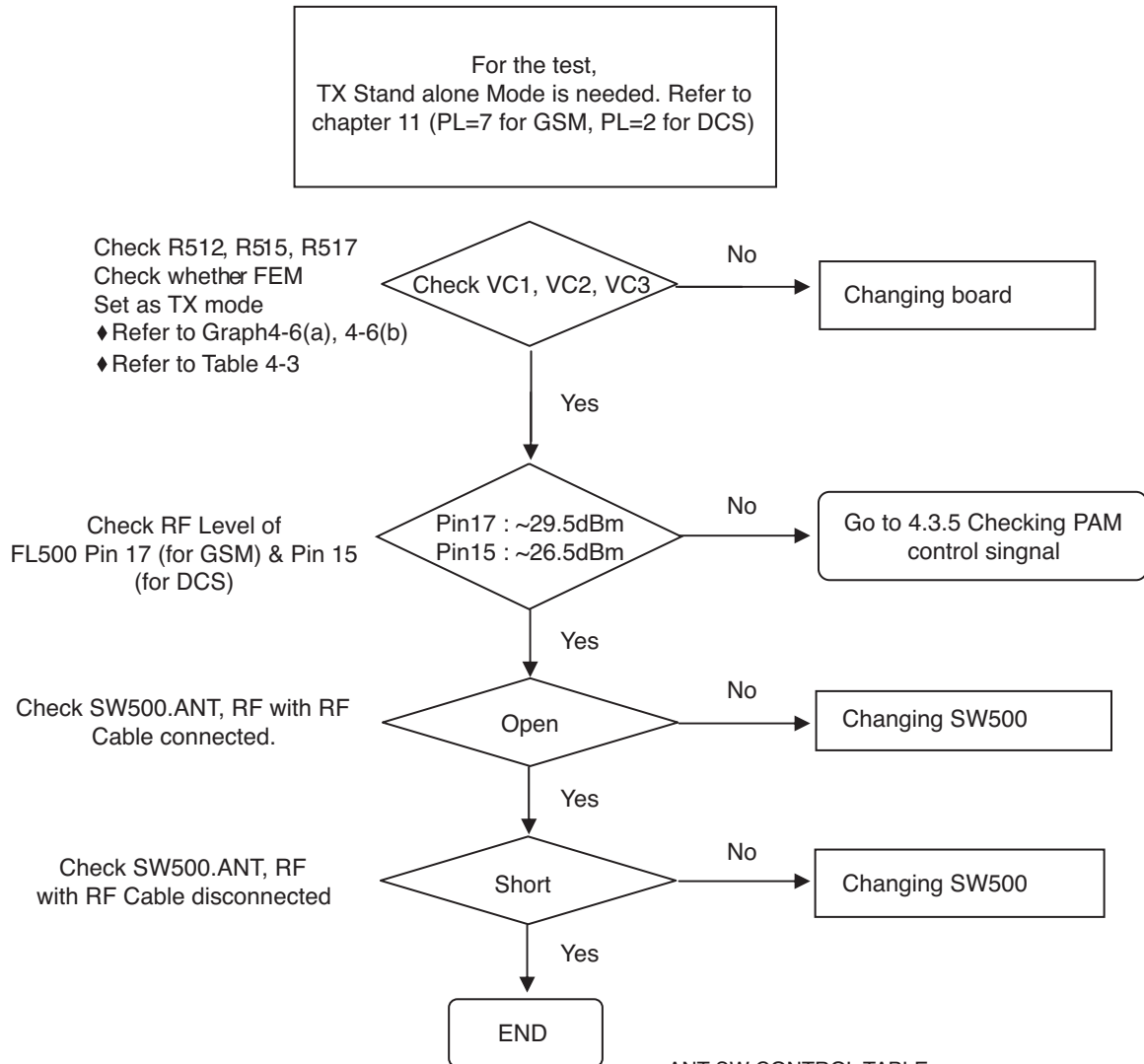

ANT SW CONTROL TABLE

	VC1	VC2	VC3
EGSM_Tx	L	L	H
DCS PCS_Tx	L	H	L
EGSM DCS_Rx	L	L	L
PCS_Rx	H	L	L

Table 4-2

(4) Checking PAM Control Signal

TEST POINT

CIRCUIT

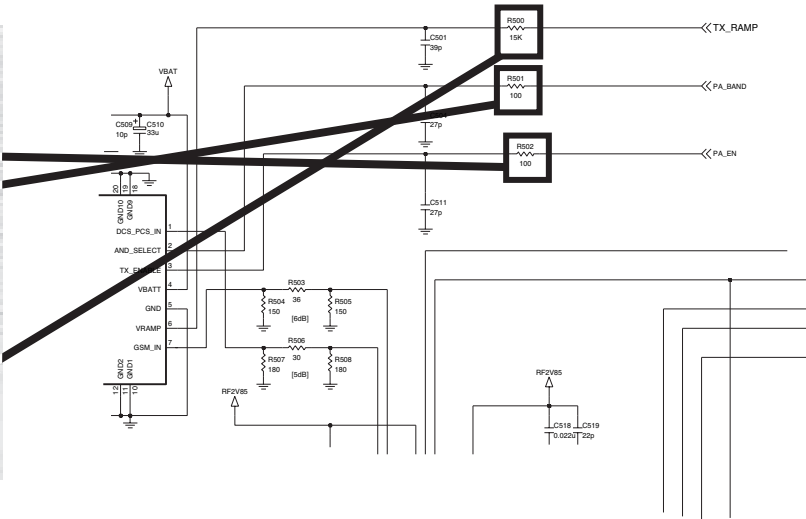
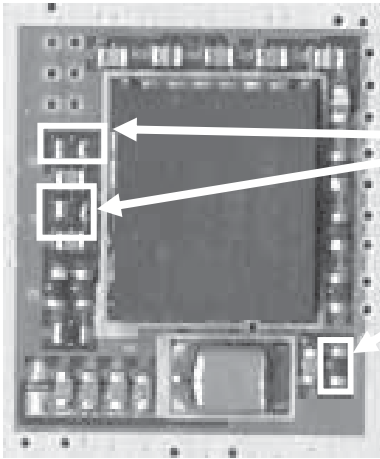

Waveform

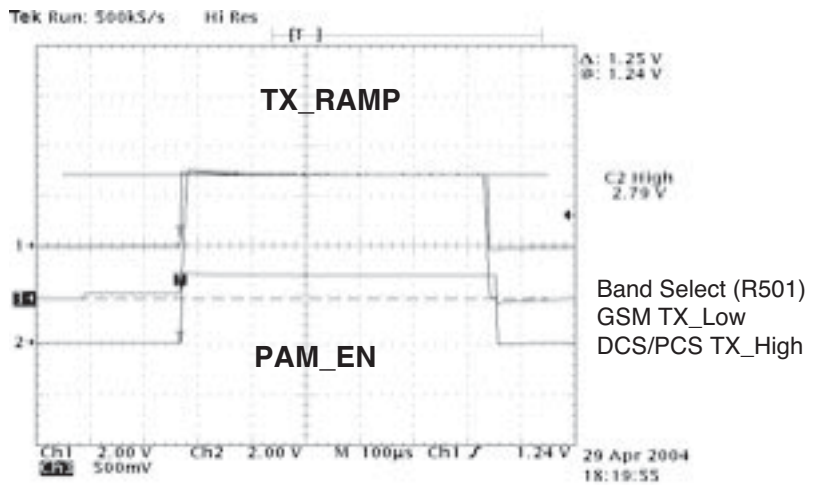

Graph 4-7

Checking Flow

Check TX_RAMP and PA_EN
Check if there is
Any Major Difference or not
Refer to Graph 4-7

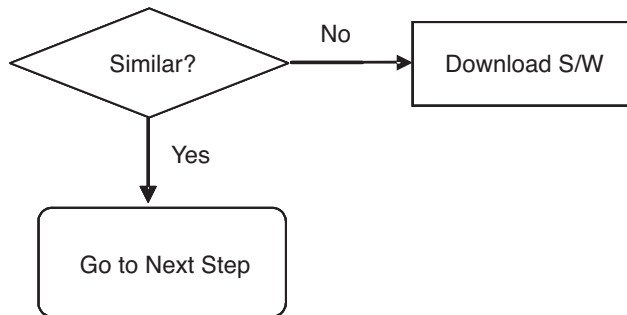

(6) Checking TX IQ

TEST POINT

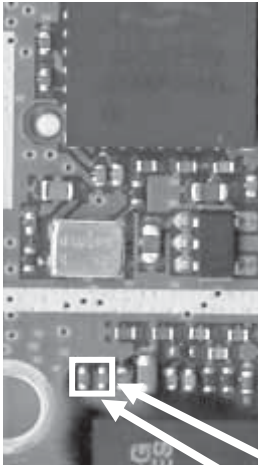

Waveform

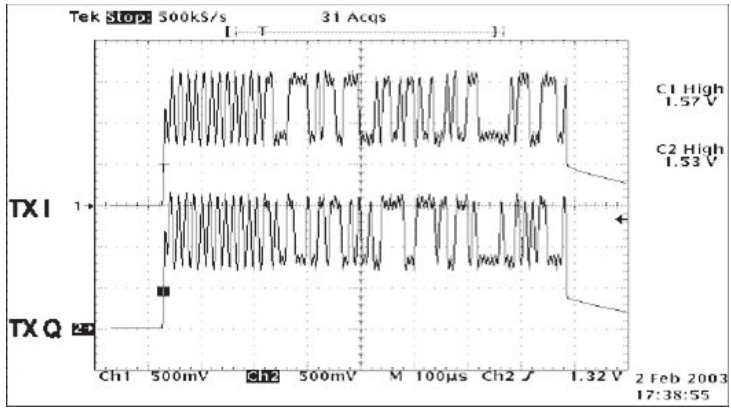

Graph 4-8

CIRCUIT

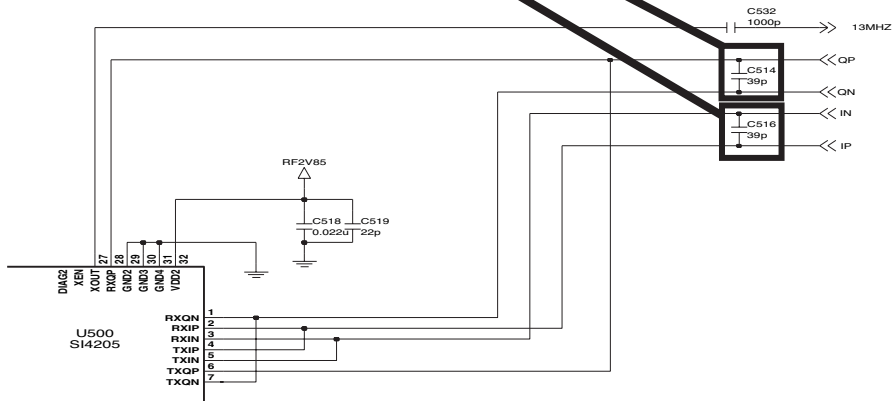

Checking Flow

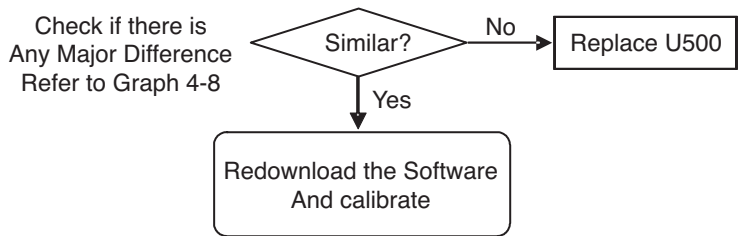

4.3 Power On Trouble

TEST POINT

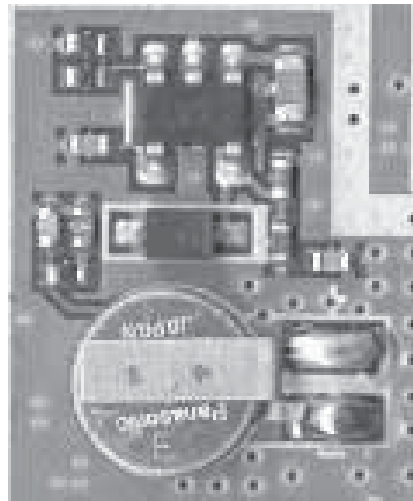
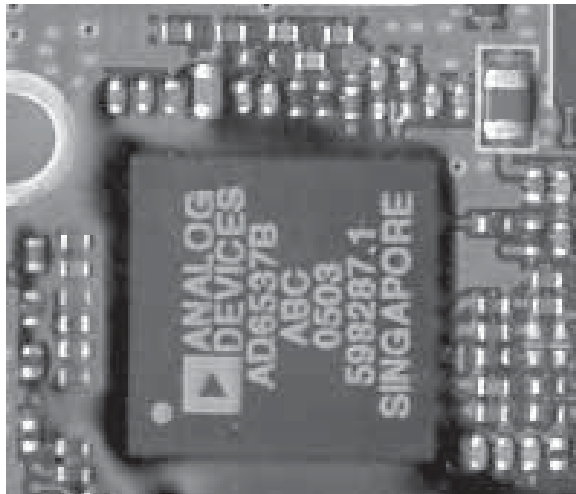

CIRCUIT

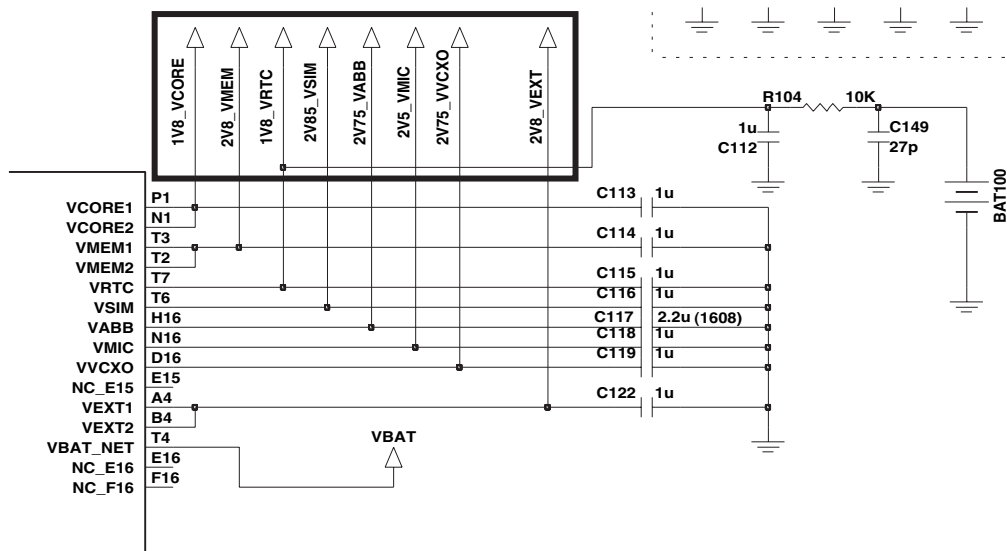

4 . TROUBLE SHOOTING

Checking Flow

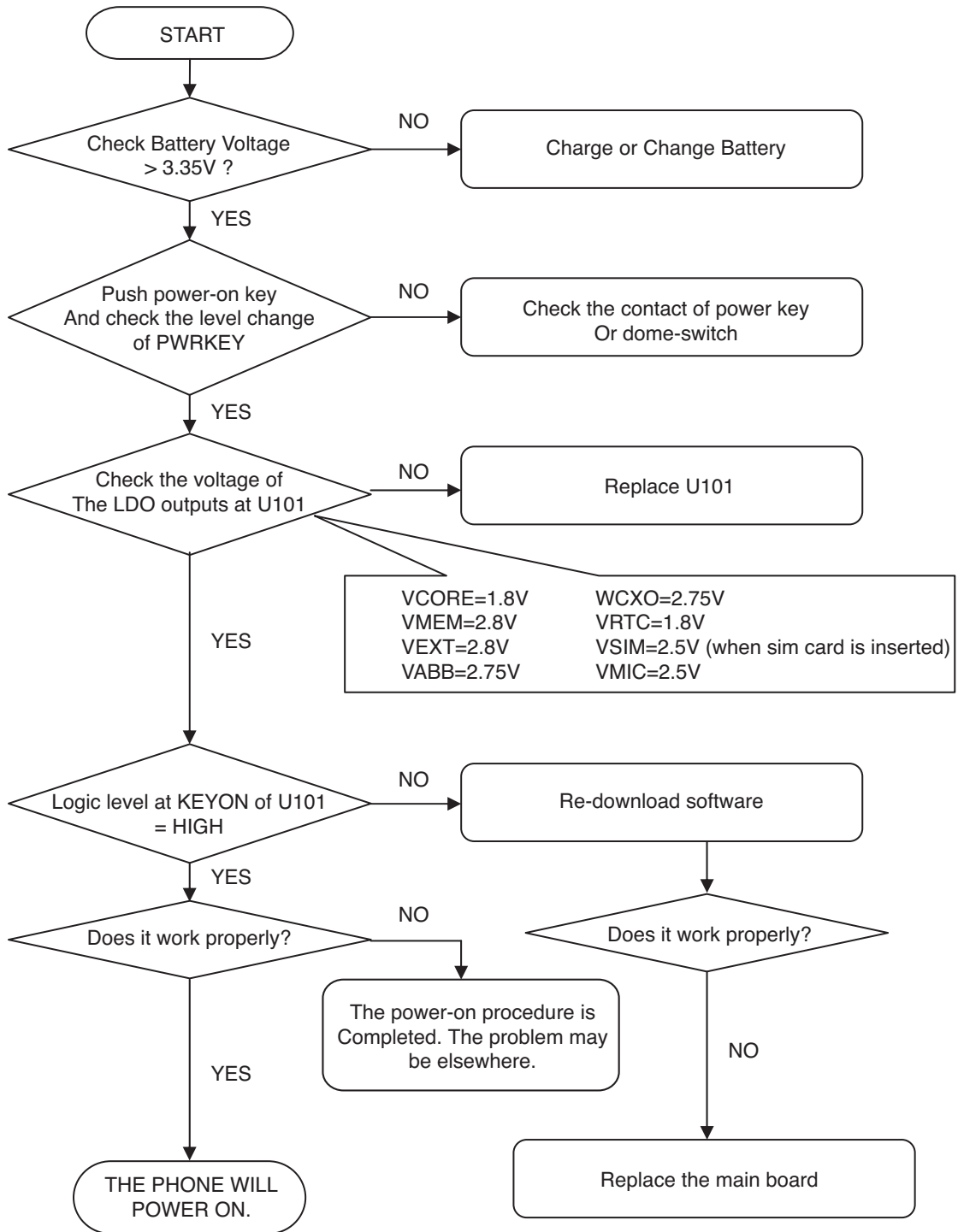

4.4 Charging Trouble

TEST POINT

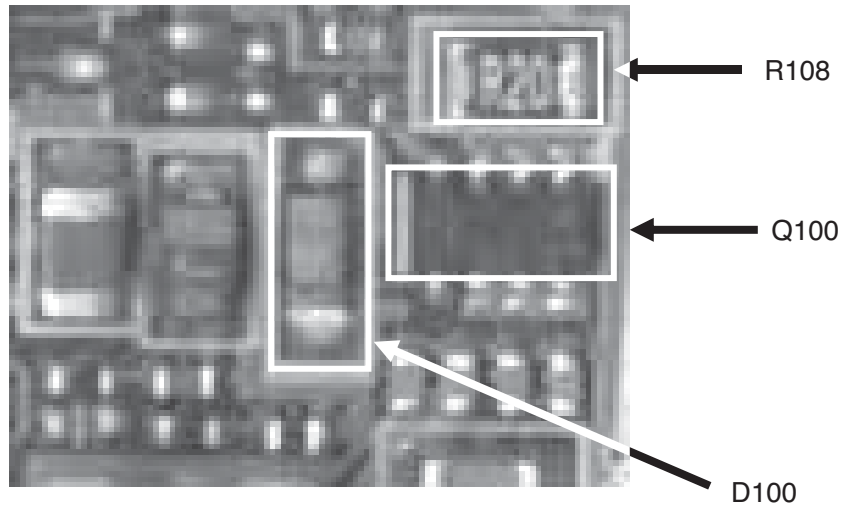

CIRCUIT

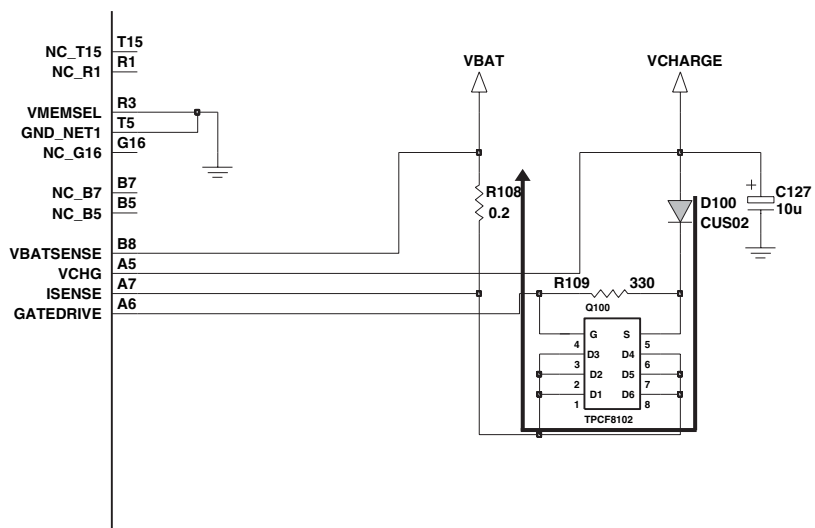

4 . TROUBLE SHOOTING

Checking Flow

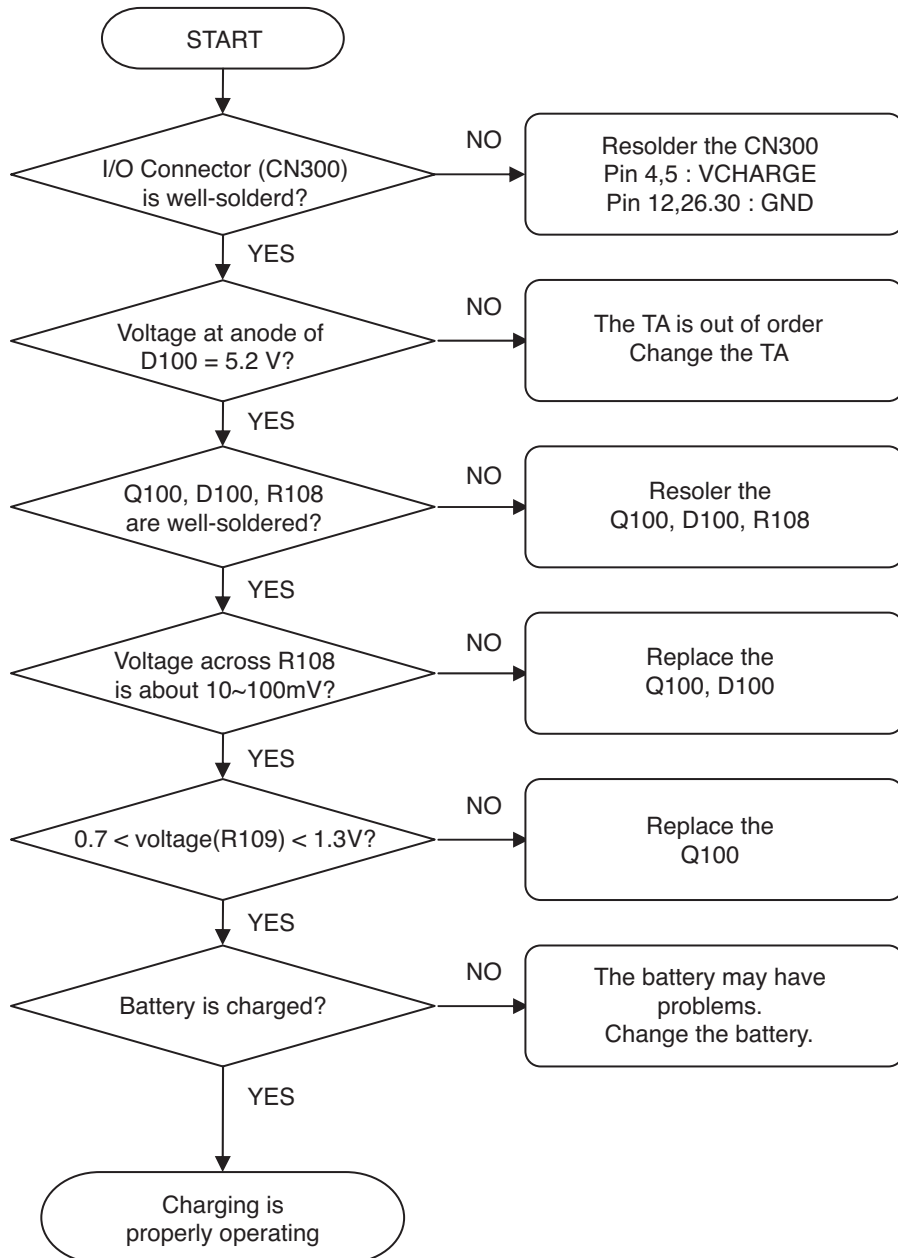

4.5 Vibrator Trouble

TEST POINT

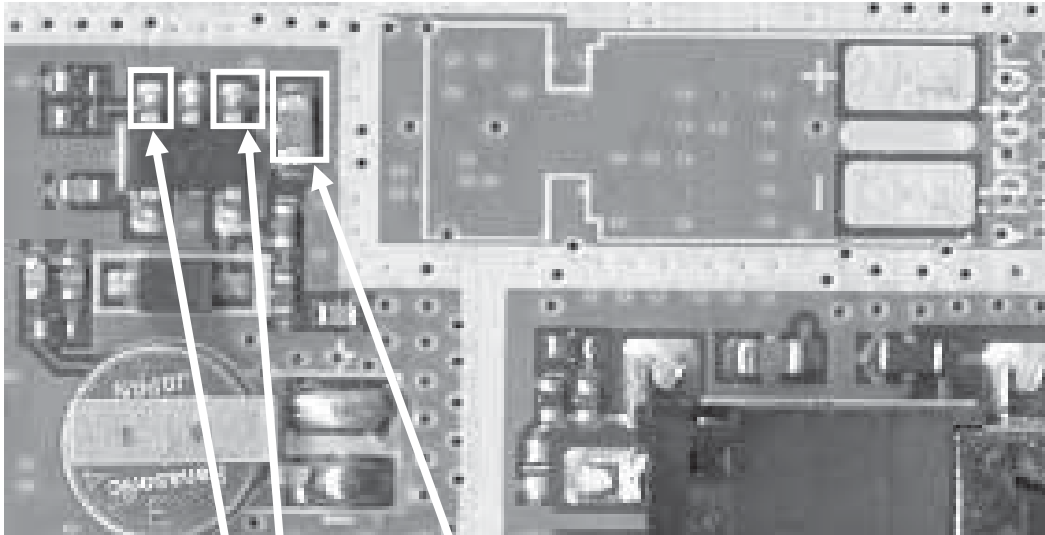

CIRCUIT

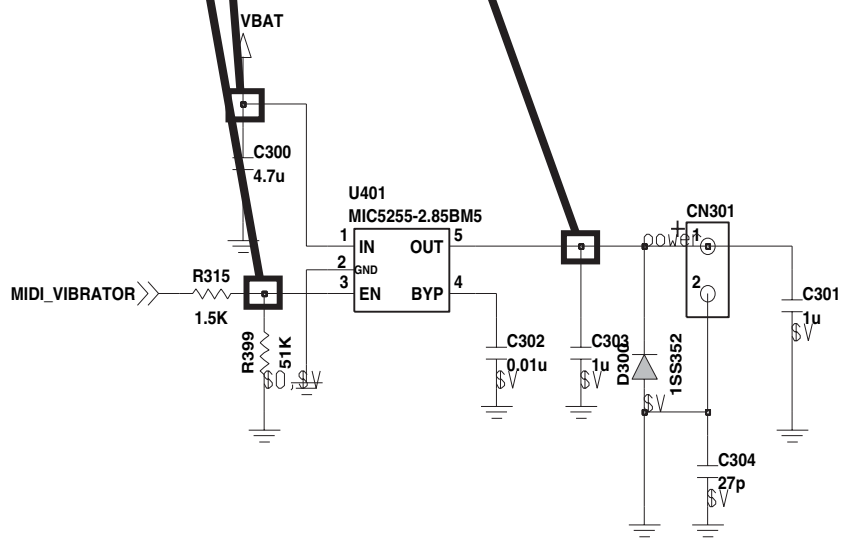

4 . TROUBLE SHOOTING

Checking Flow

SETTING : Enter the engineering mode, and set vibrator on at vibration of BB test menu

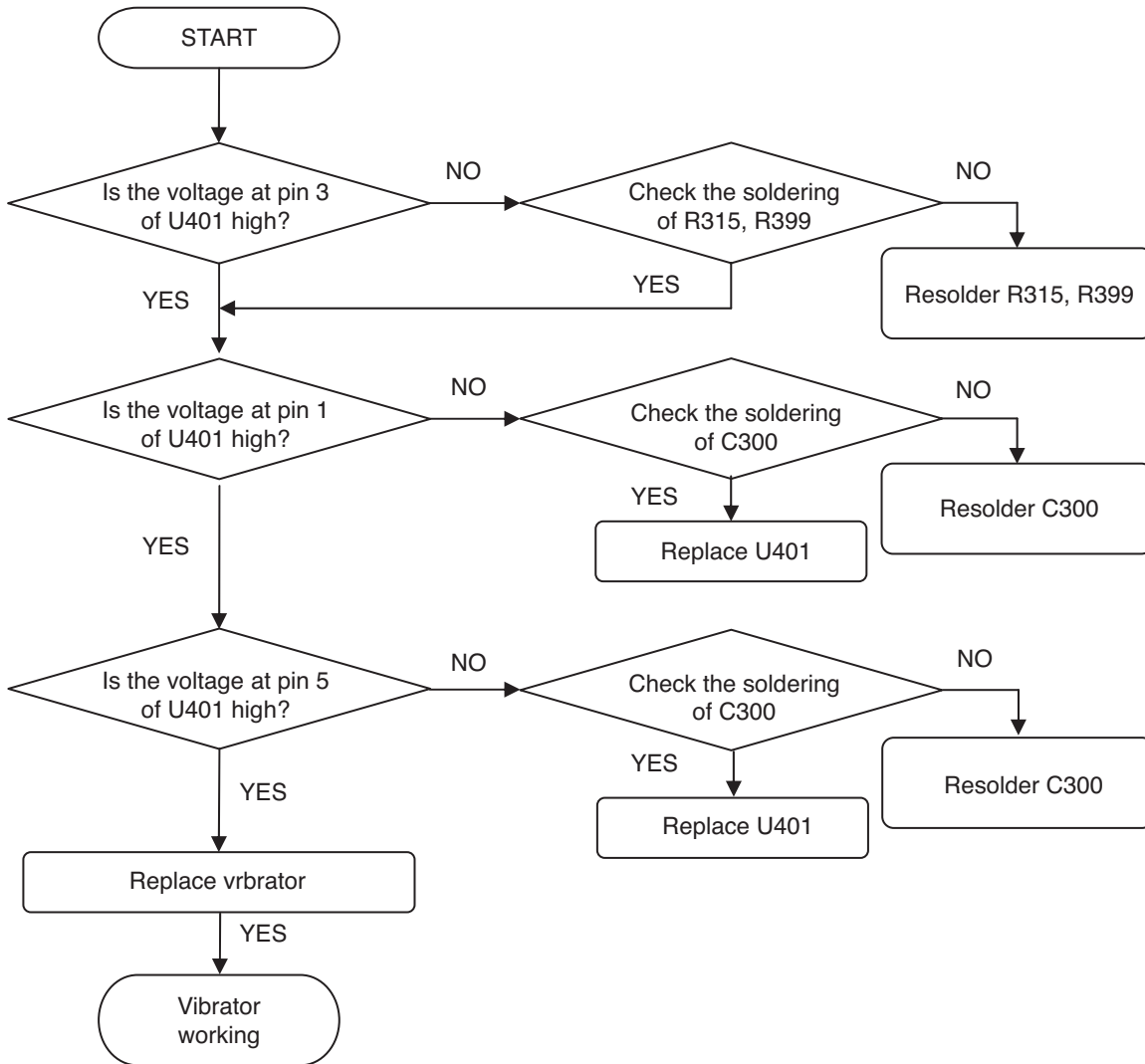

4.6 LCD Trouble

TEST POINT

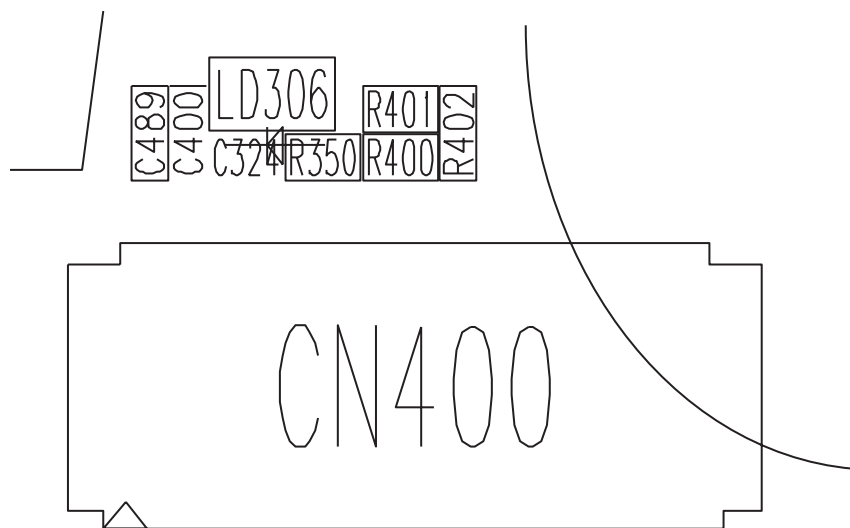
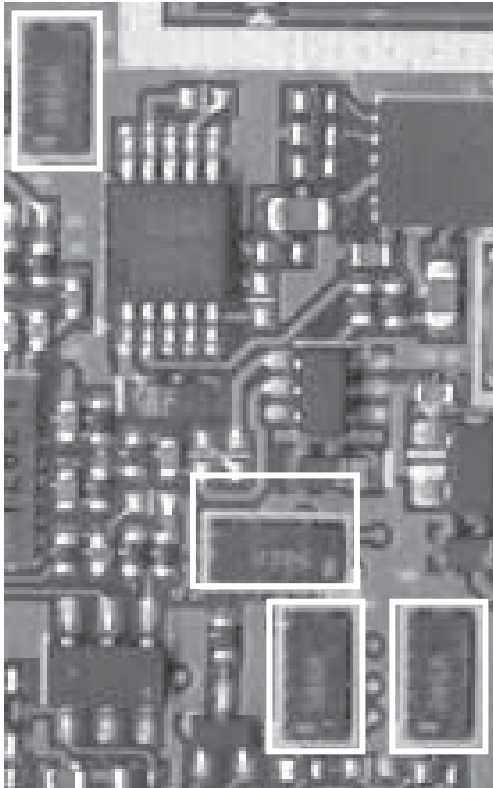

4 . TROUBLE SHOOTING

Checking Flow

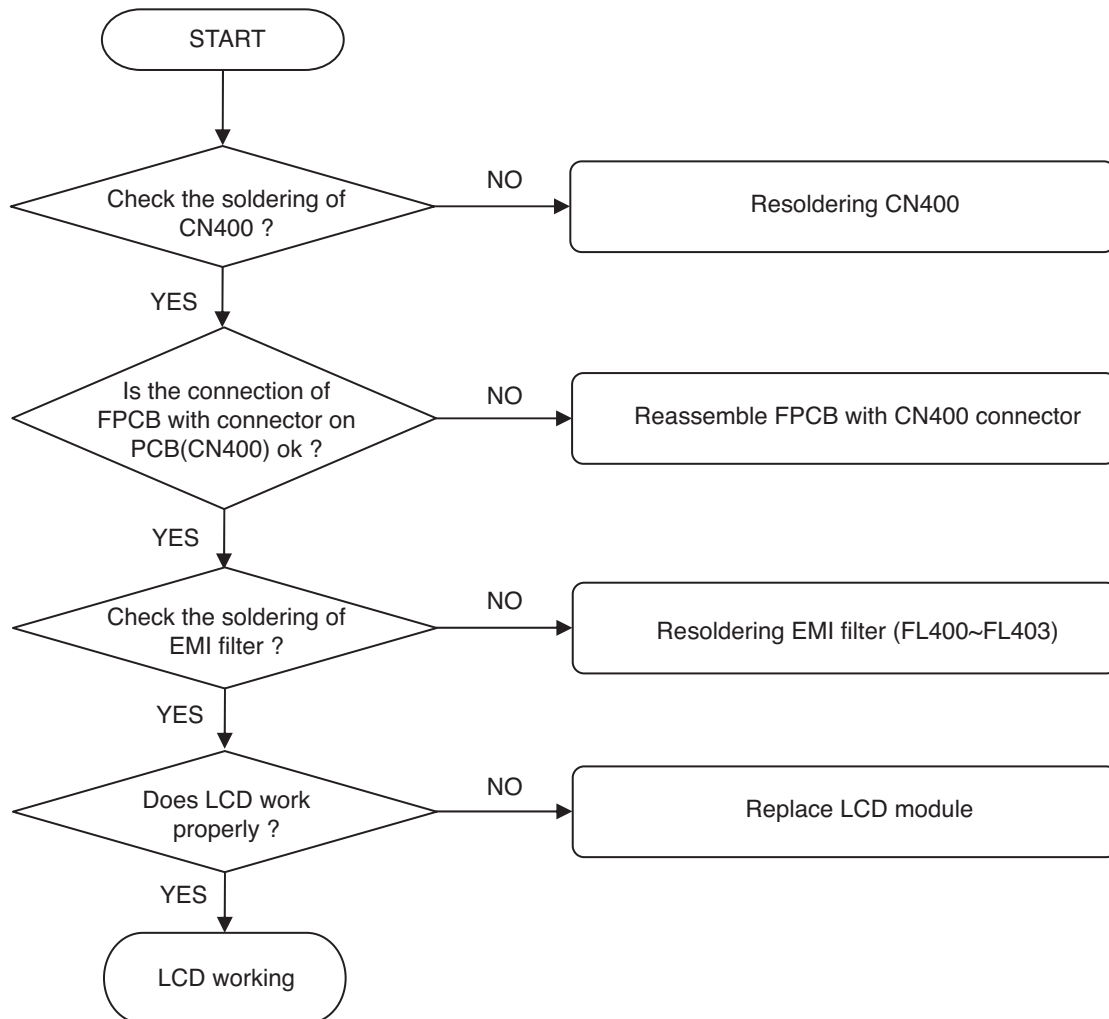

4.7 Radio Trouble

TEST POINT

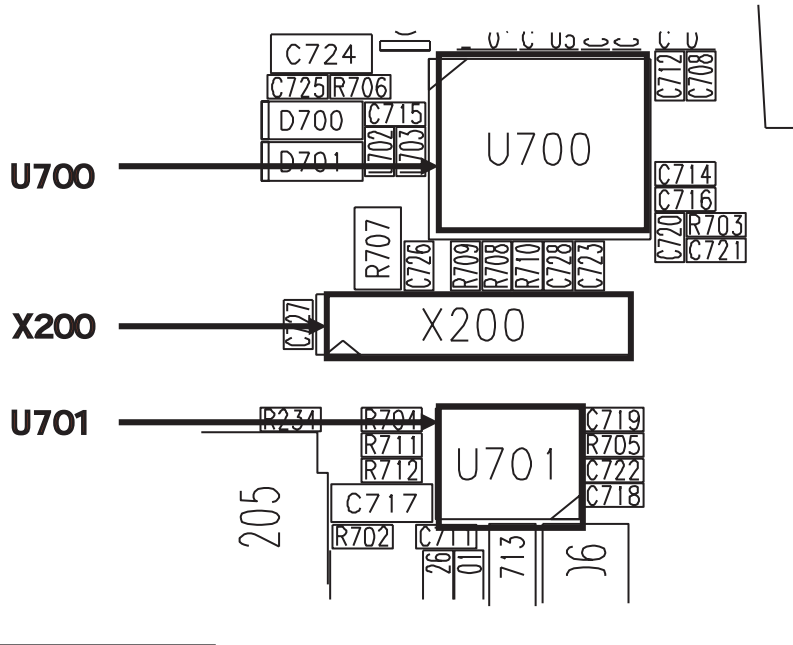

CIRCUIT

RADIO(OPTION)

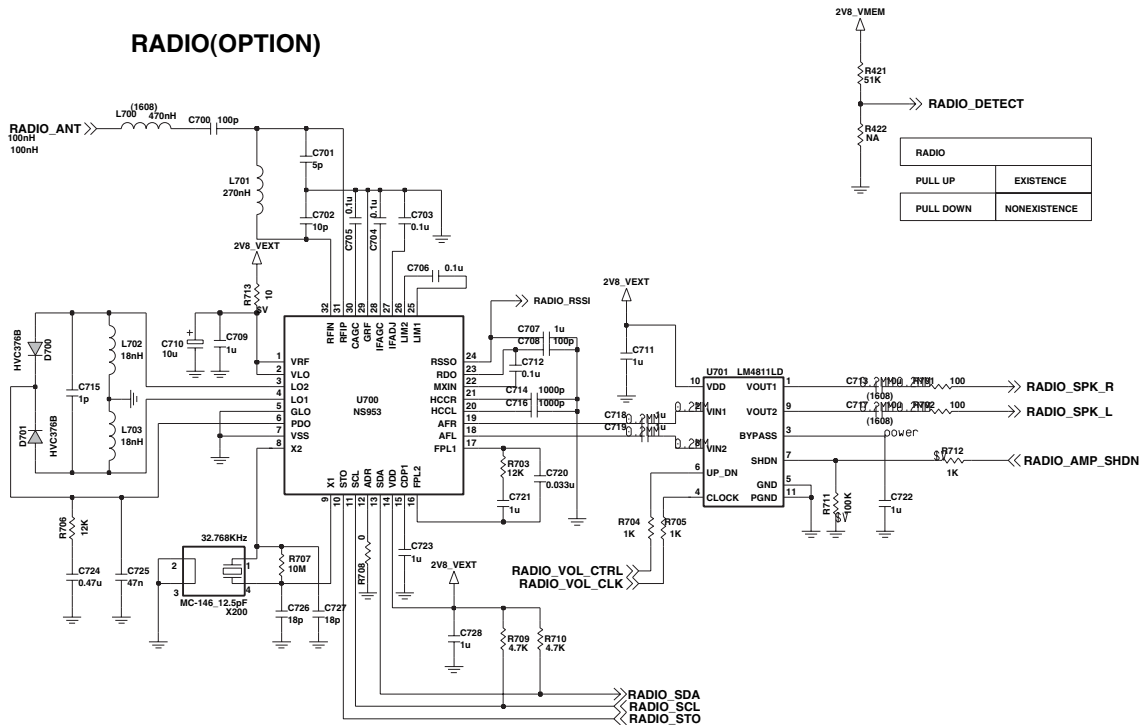

4 . TROUBLE SHOOTING

Checking Flow

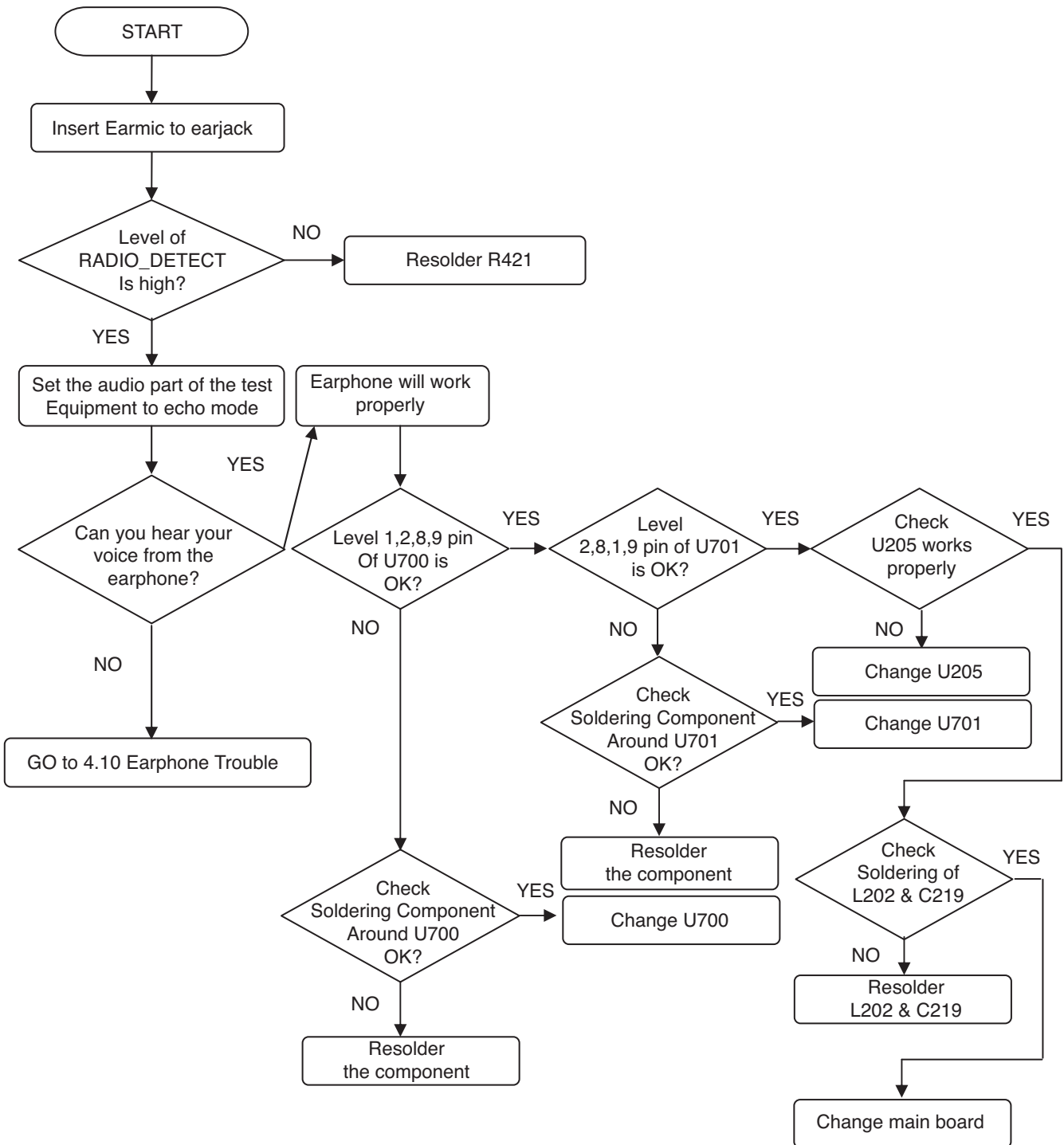

4.8 Speaker Trouble

TEST POINT

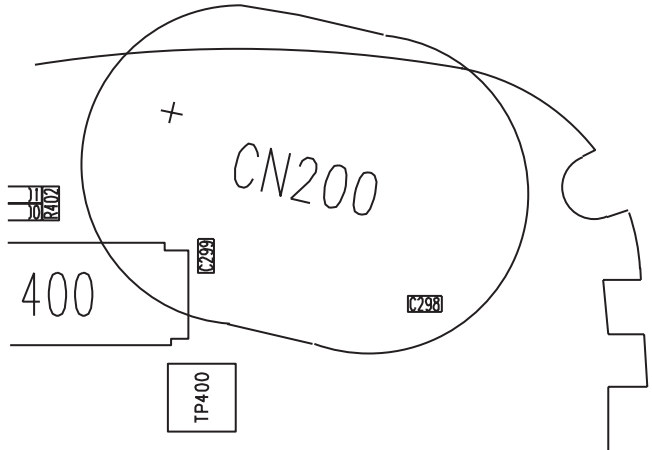
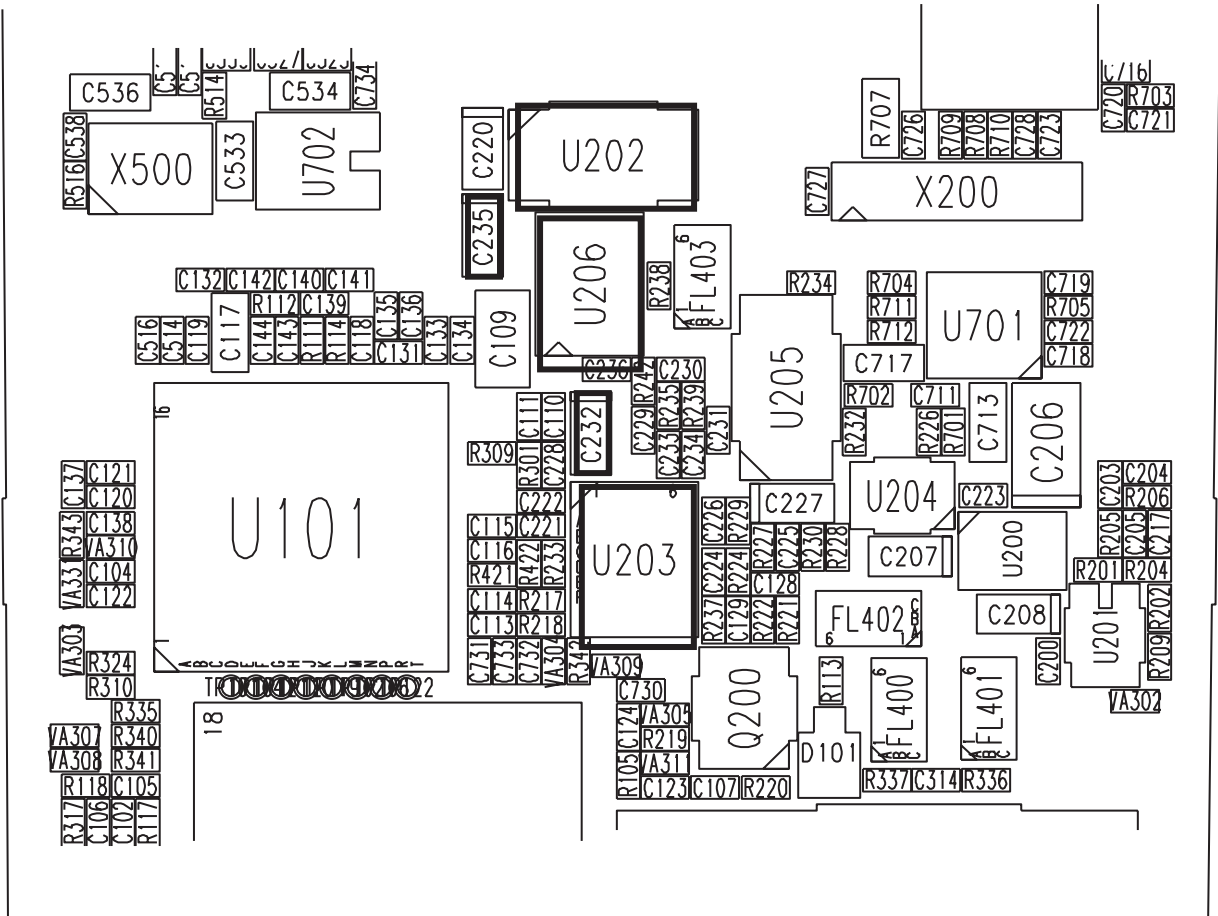

4 . TROUBLE SHOOTING

CIRCUIT DIAGRAM

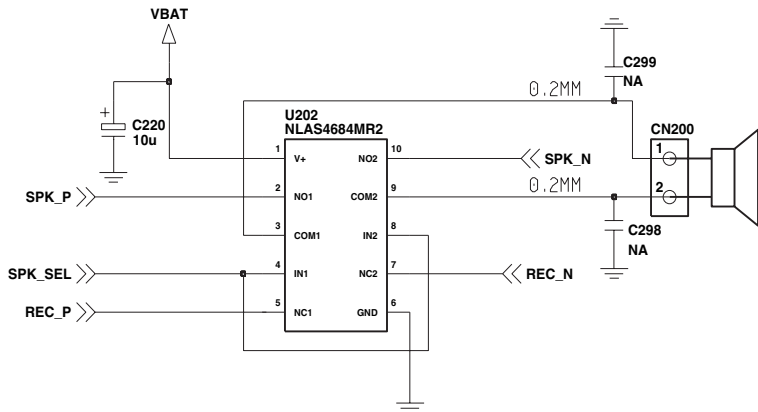
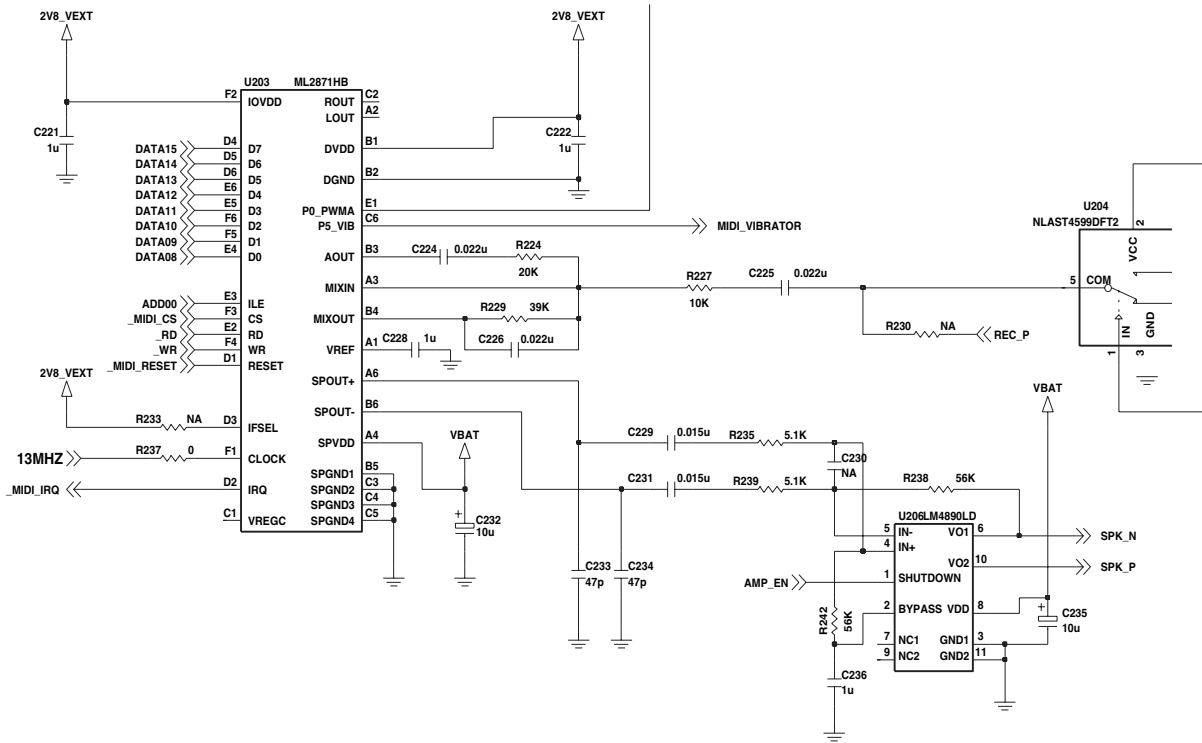

Checking Flow

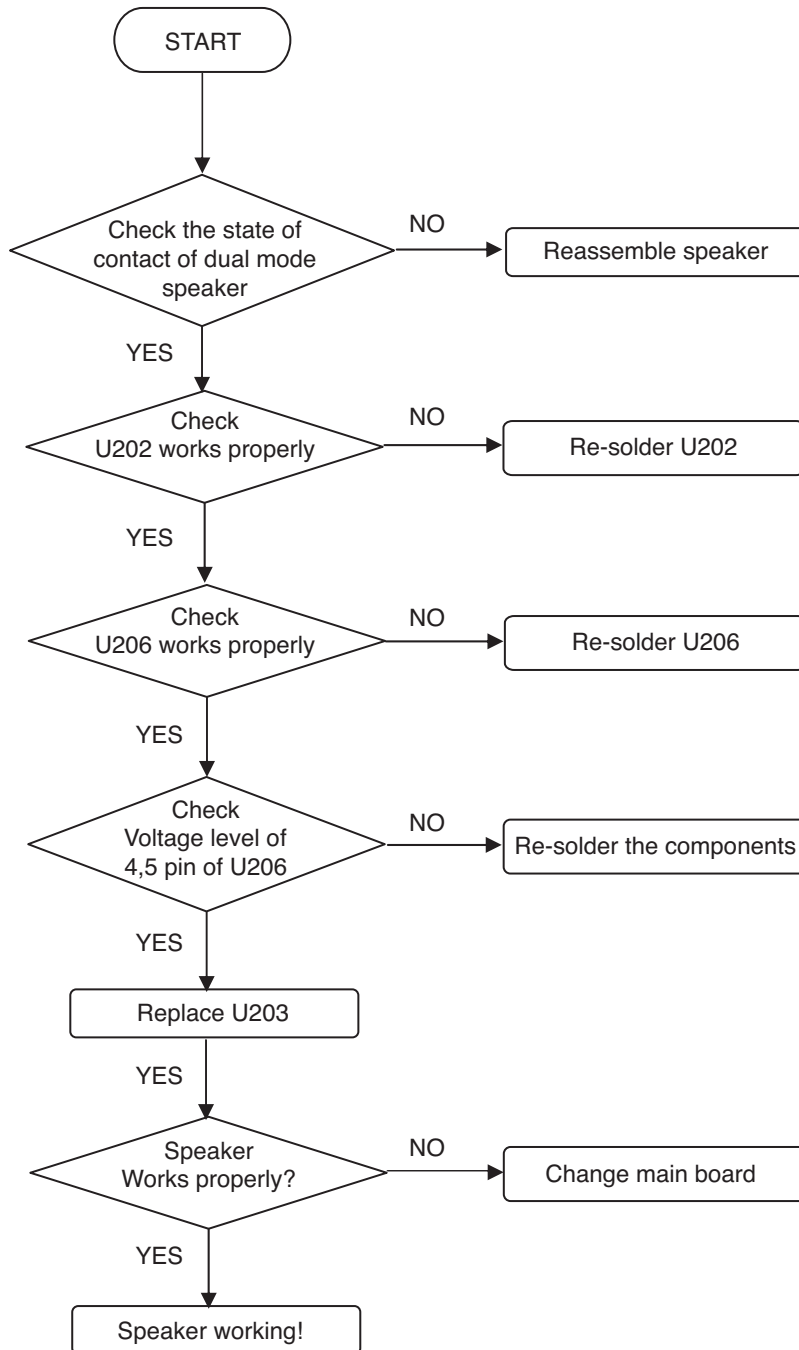

4.9 SIM Card Interface Trouble

TEST POINT

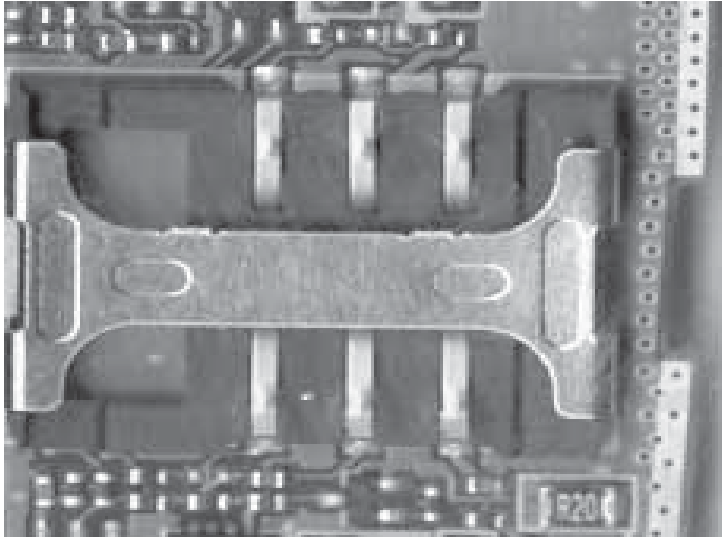

CIRCUIT DIAGRAM

SIM CONNECTOR

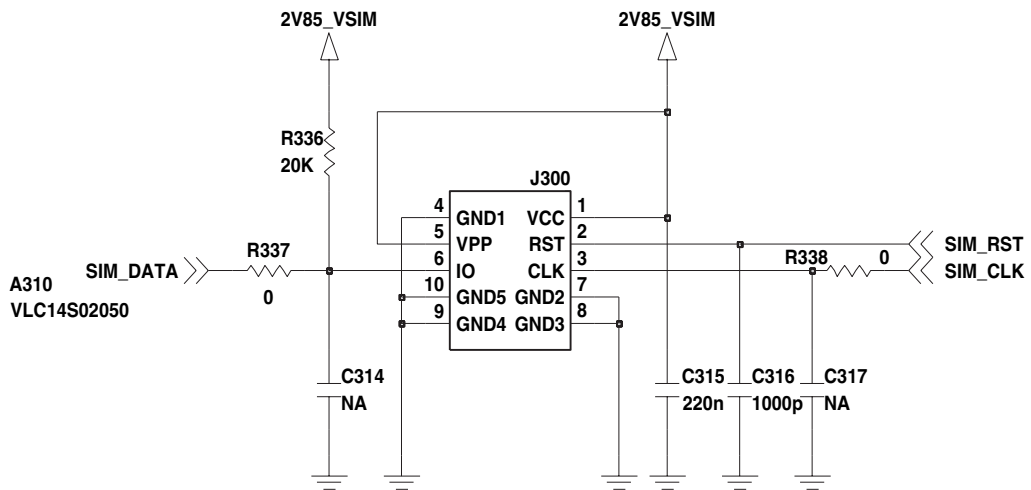

Checking Flow

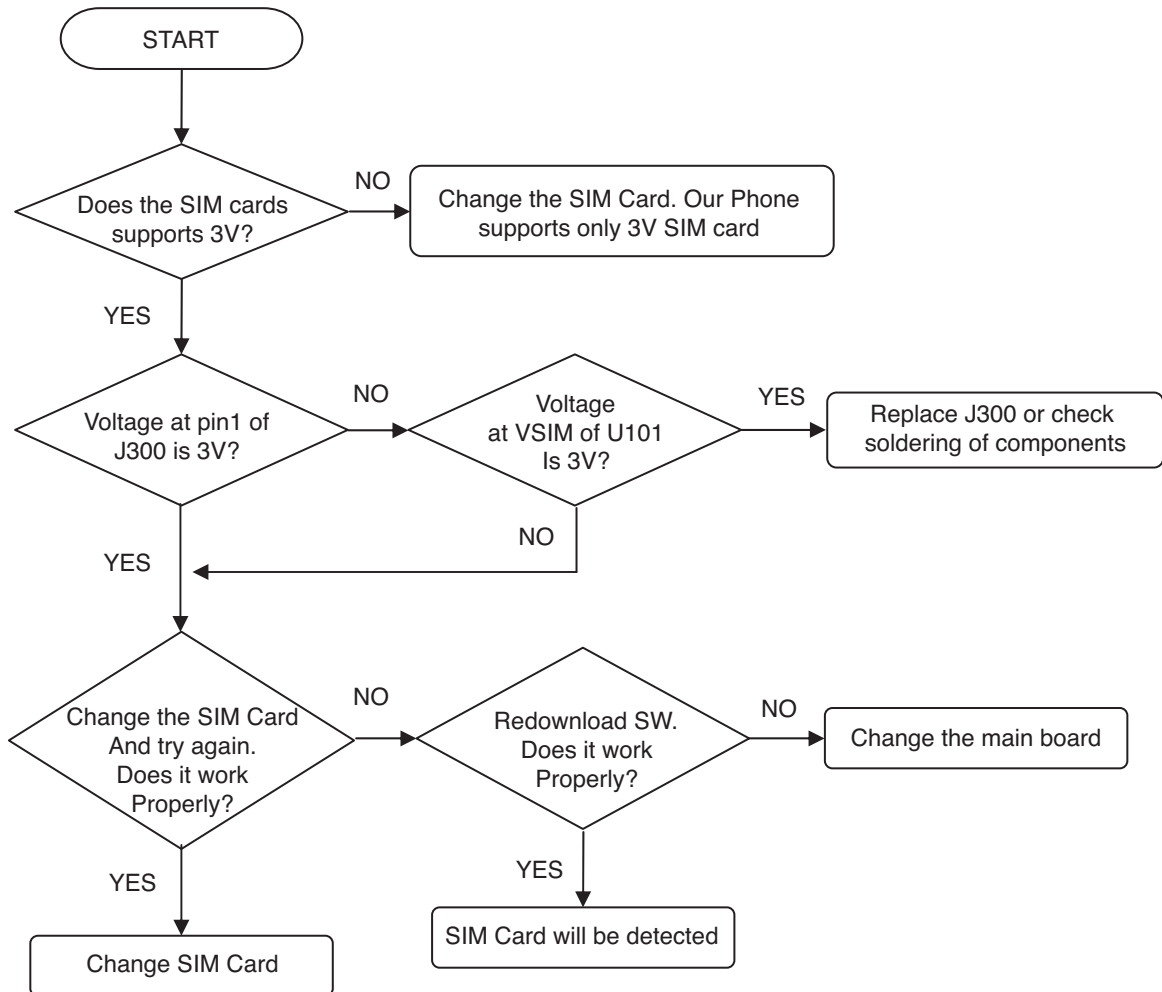

4.10 Earphone Trouble

TEST POINT

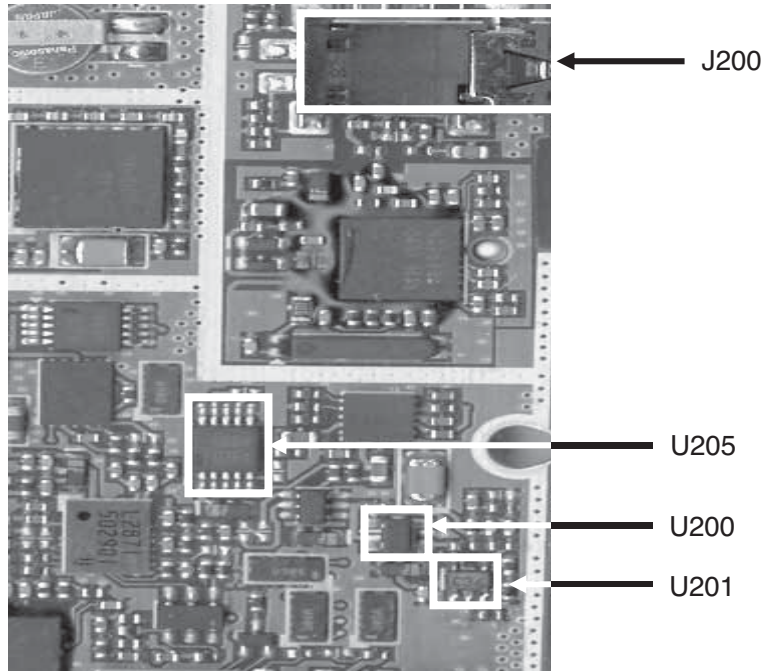

CIRCUIT DIAGRAM

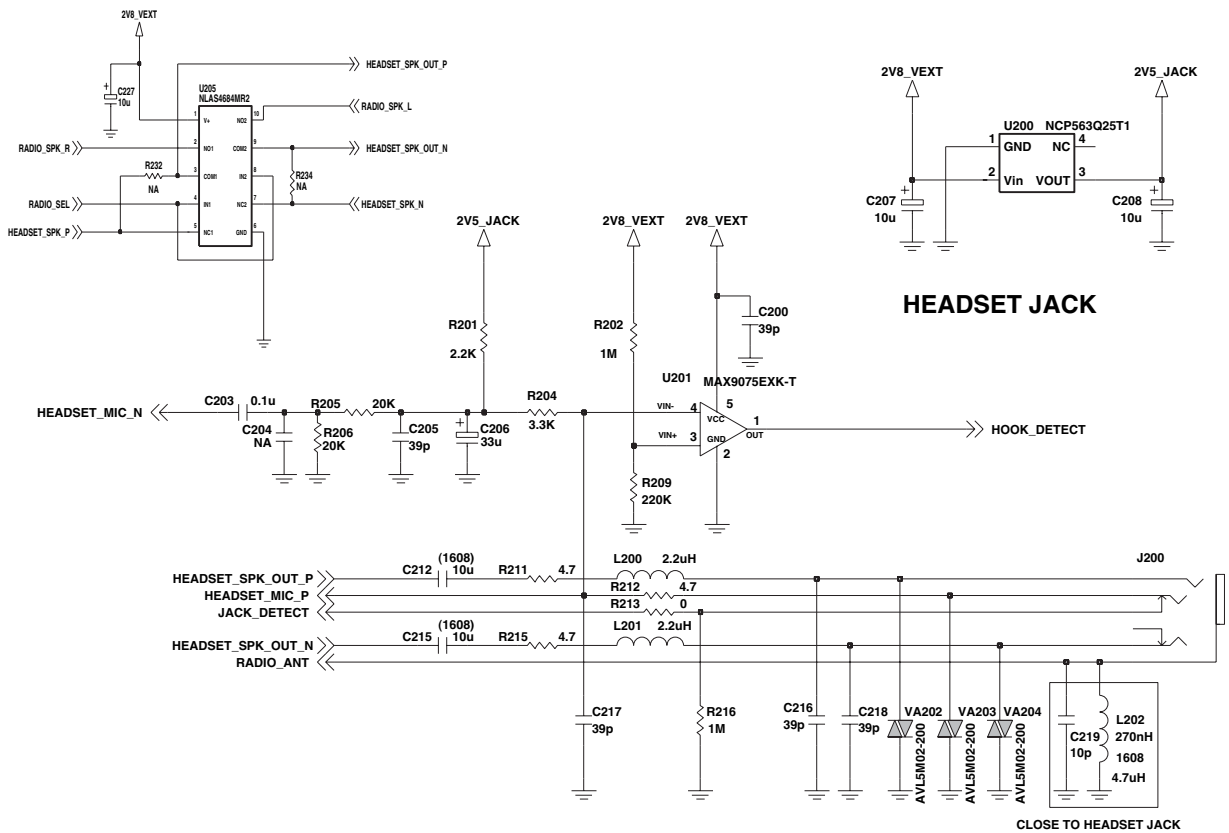

Checking Flow

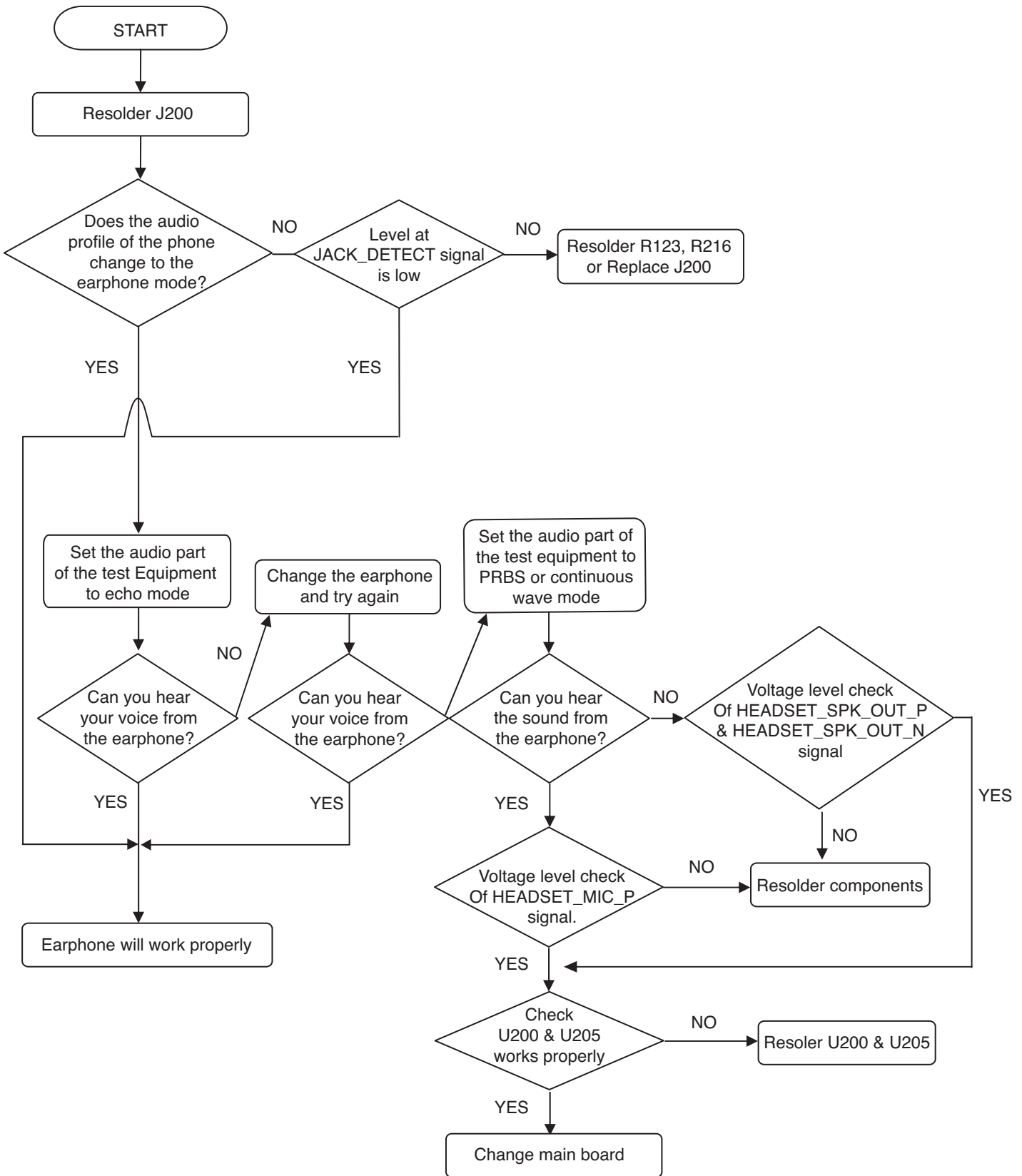

4.11 KEY backlight Trouble

TEST POINT

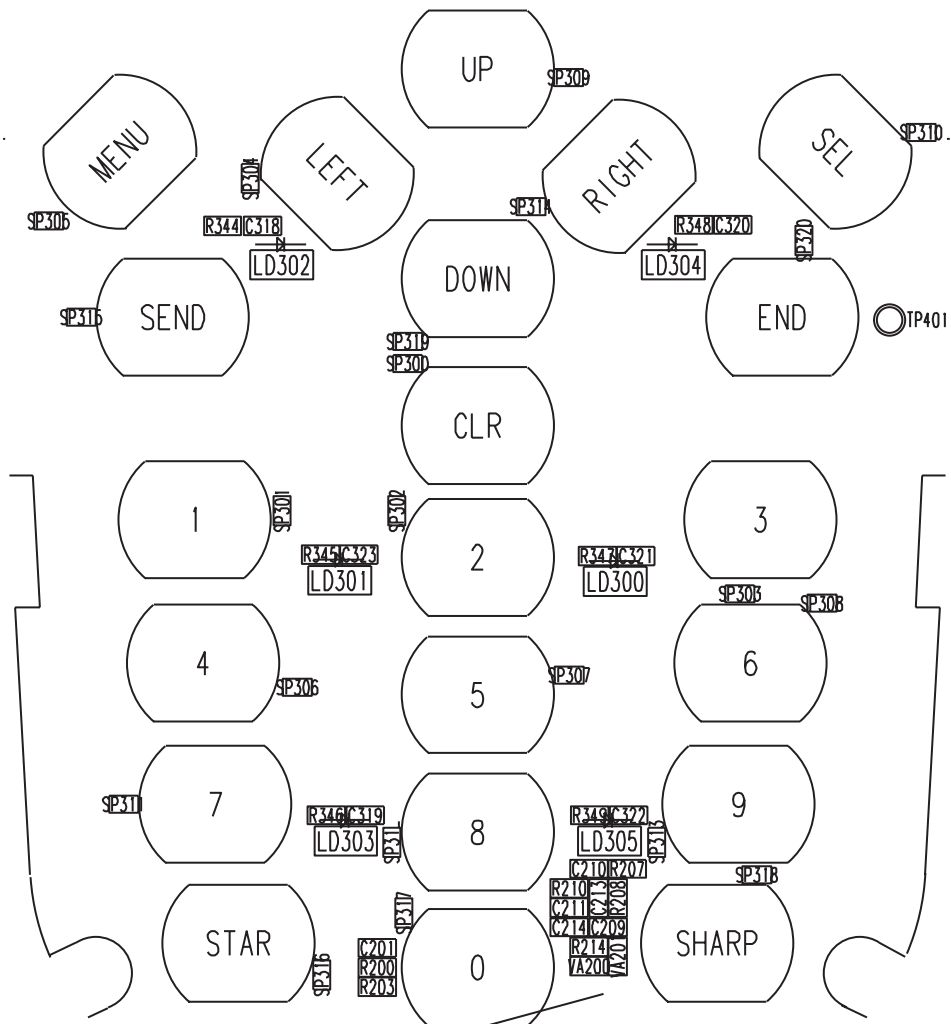

CIRCUIT DIAGRAM

KEY BACKLIGHT

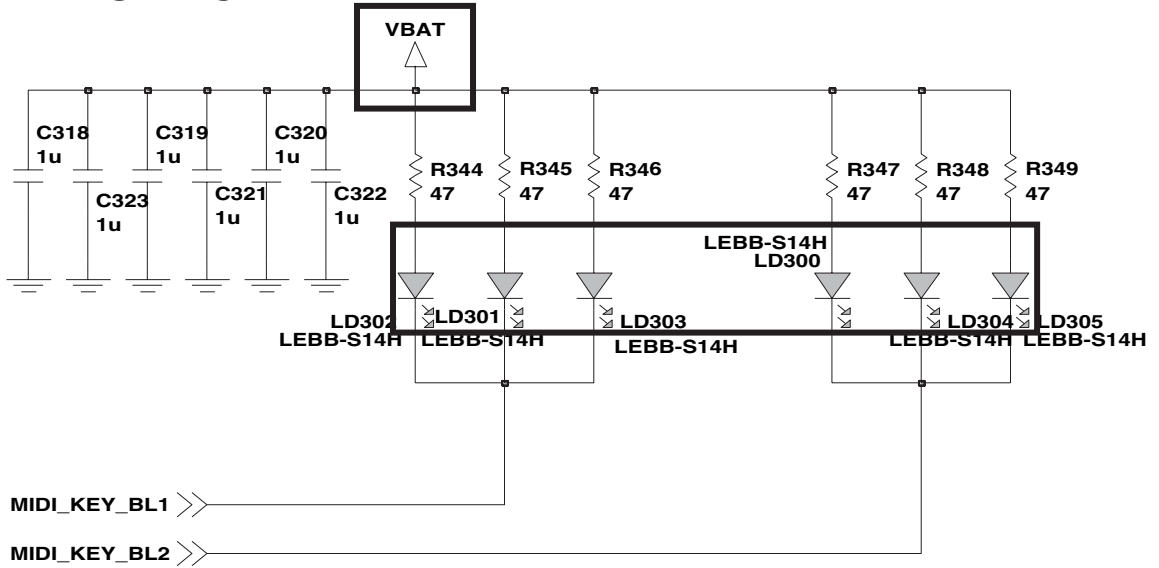

Checking Flow

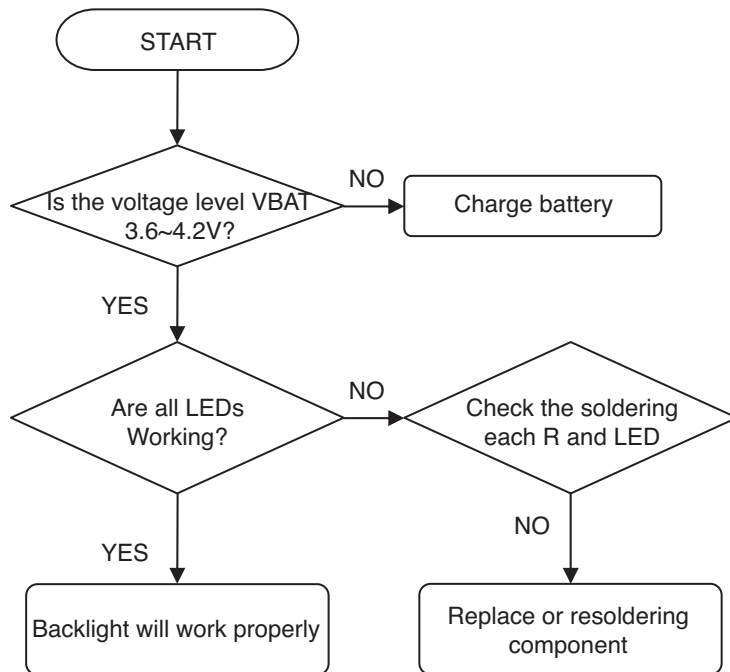

4.12 Receiver Trouble

TEST POINT



CIRCUIT DIAGRAM

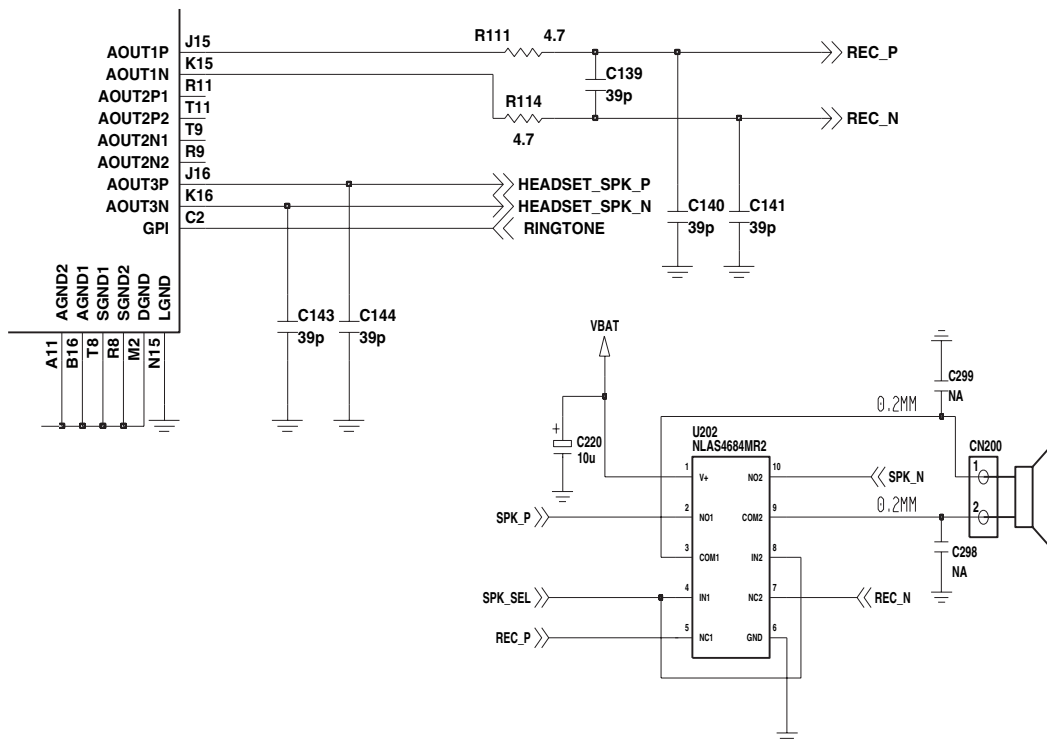

Checking Flow

SETTING : After initialize Agilent 8960, Test EGSM, DCS mode

Set the property of audio as PRBS or continuous wave. Set the receiving volume of mobile as Max.

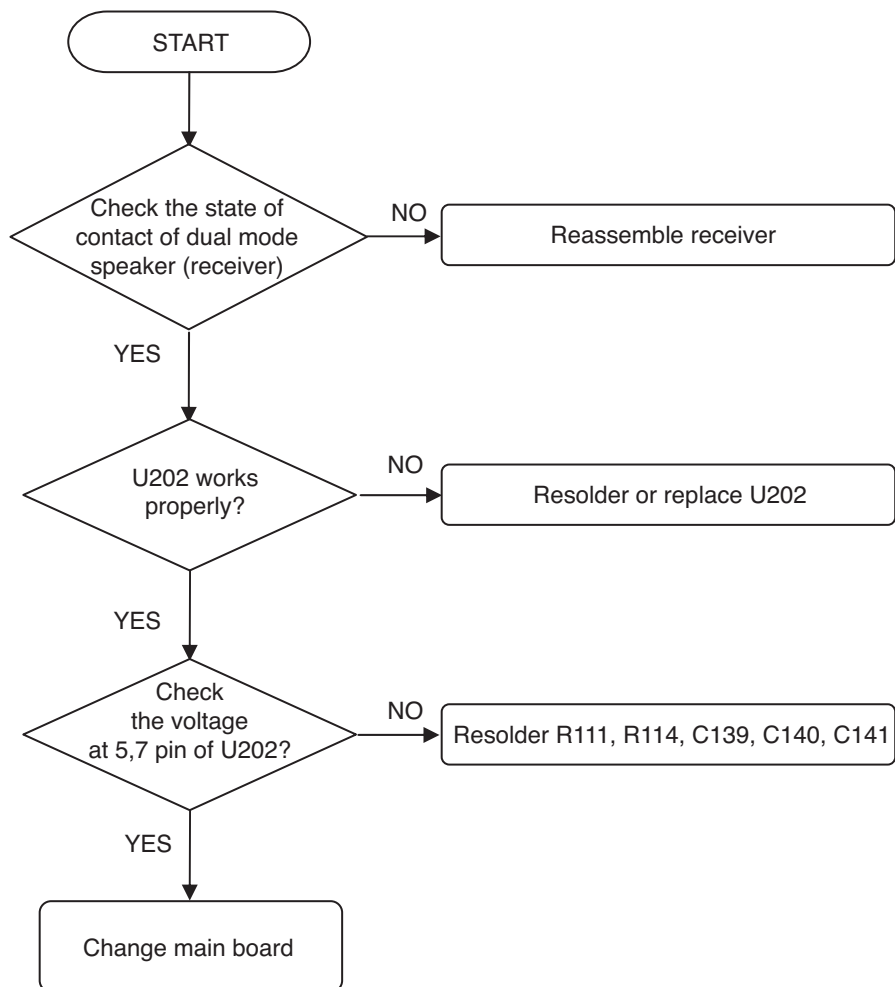

4.13 Microphone Trouble

TEST POINT

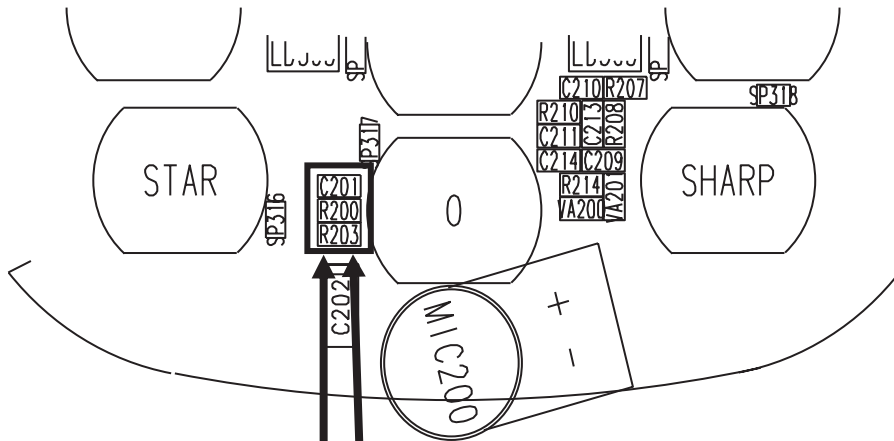

CIRCUIT DIAGRAM

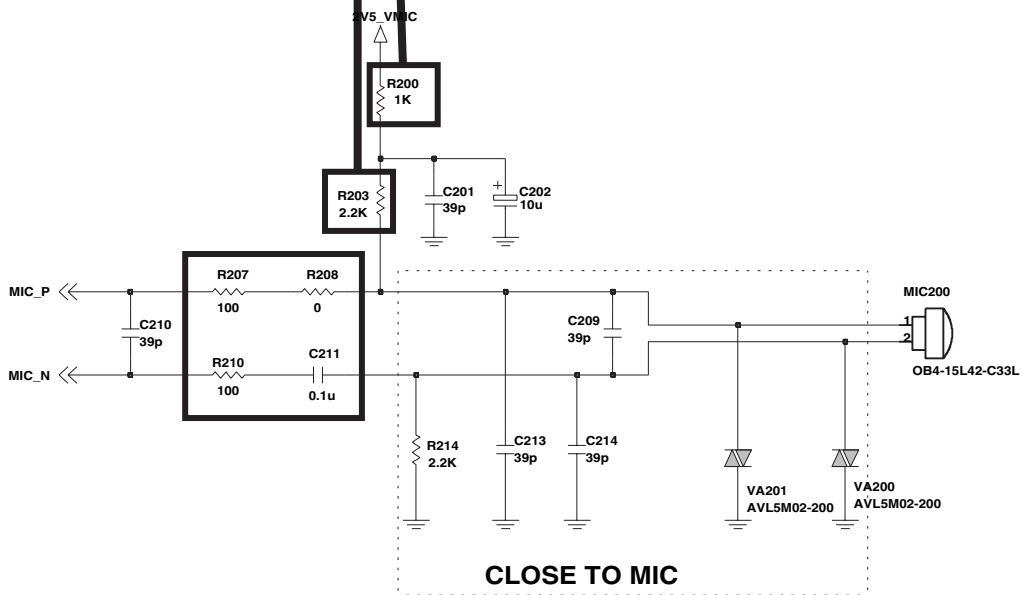

Checking Flow

SETTING : After initialize Agilent 8960, Test EGSM, DCS mode

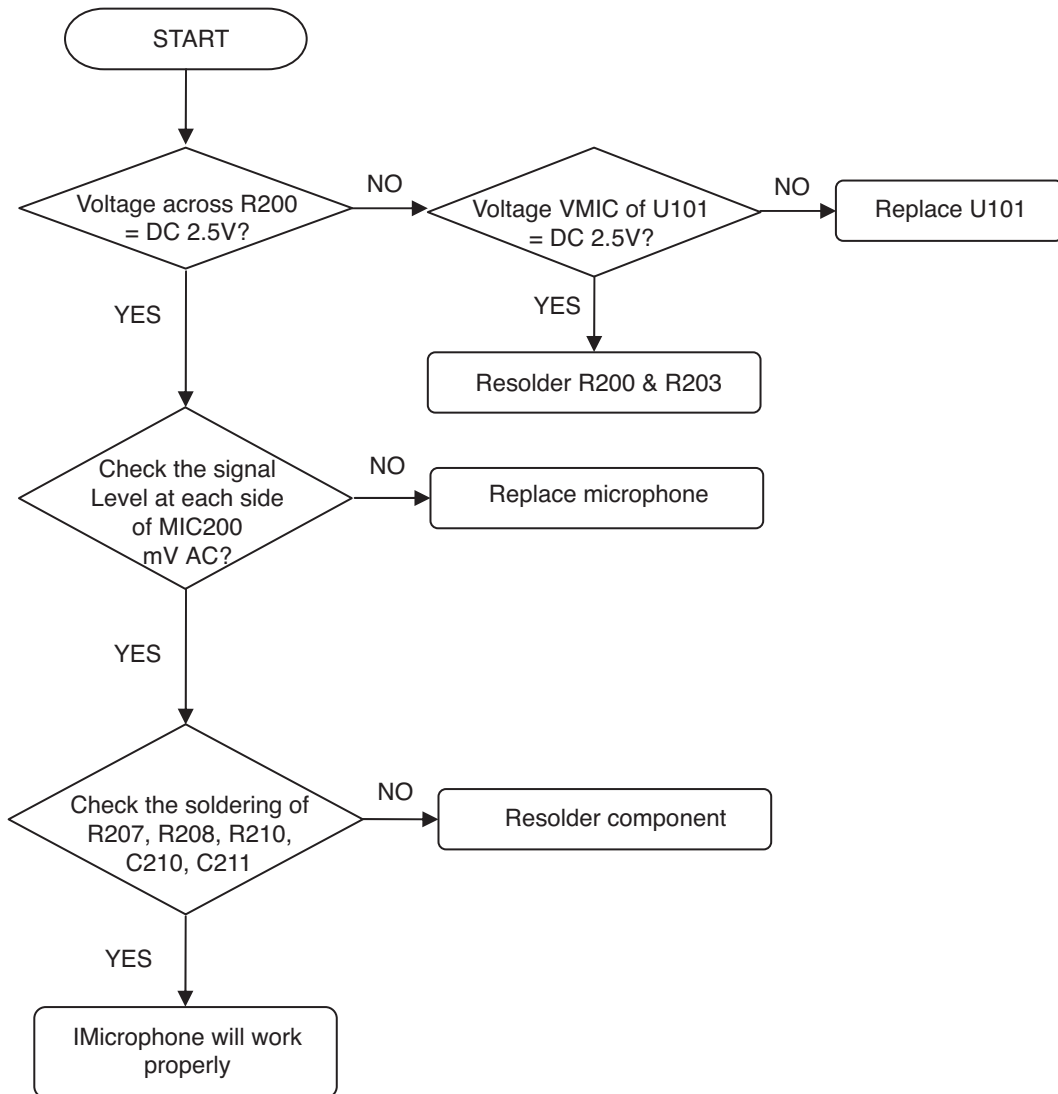

4.14 RTC Trouble

TEST POINT

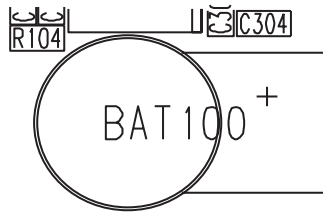
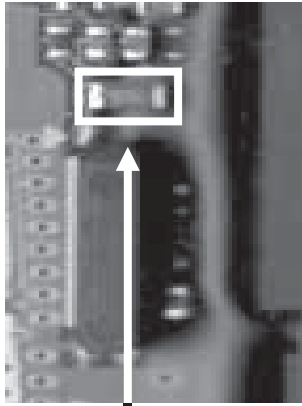

CIRCUIT DIAGRAM

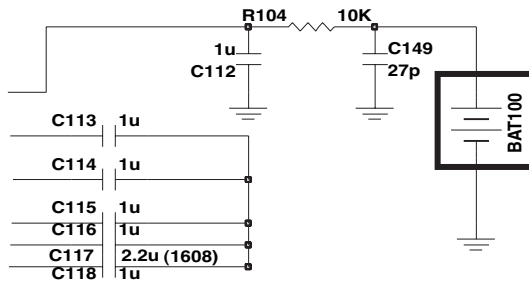
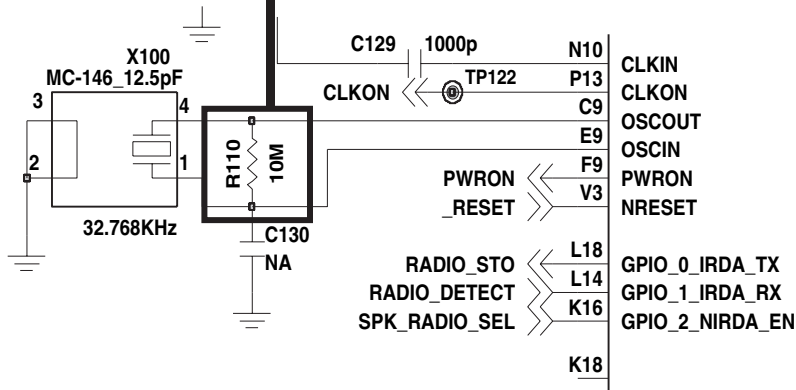

Checking Flow

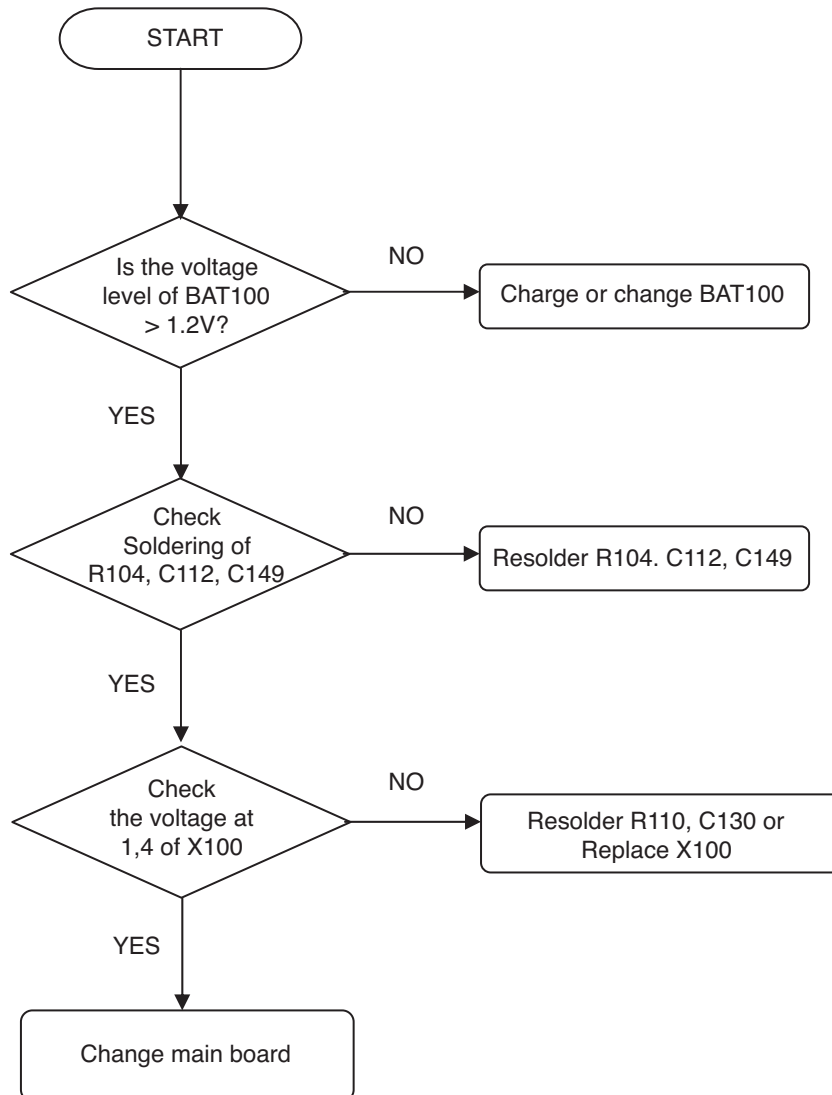

4.15 Indication LED Trouble

TEST POINT

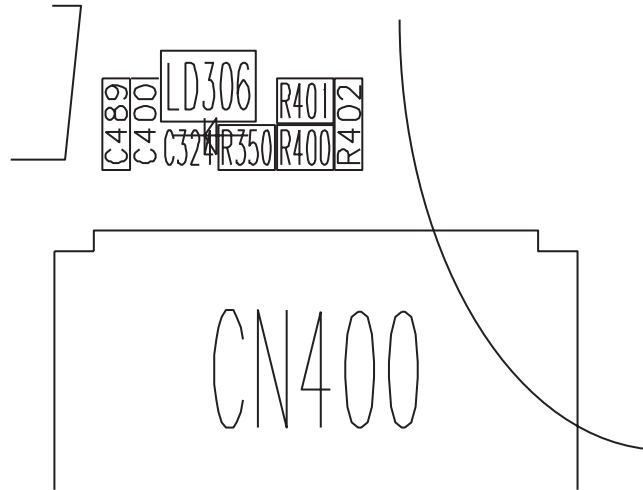
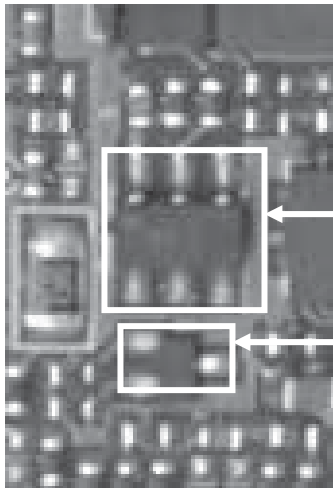

CIRCUIT DIAGRAM

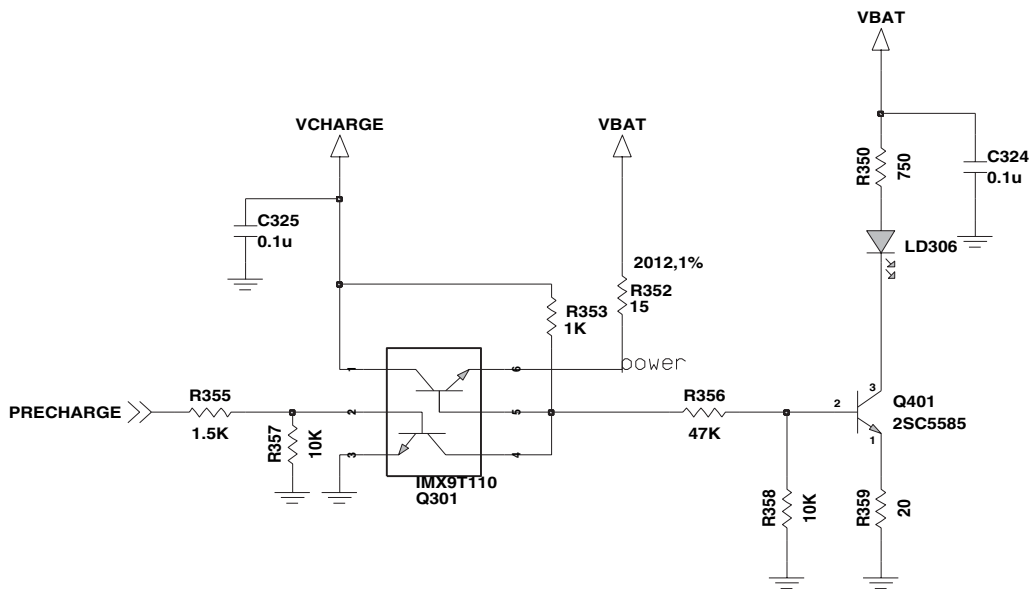

Checking Flow

Indication LED only operates in trickle charging mode.

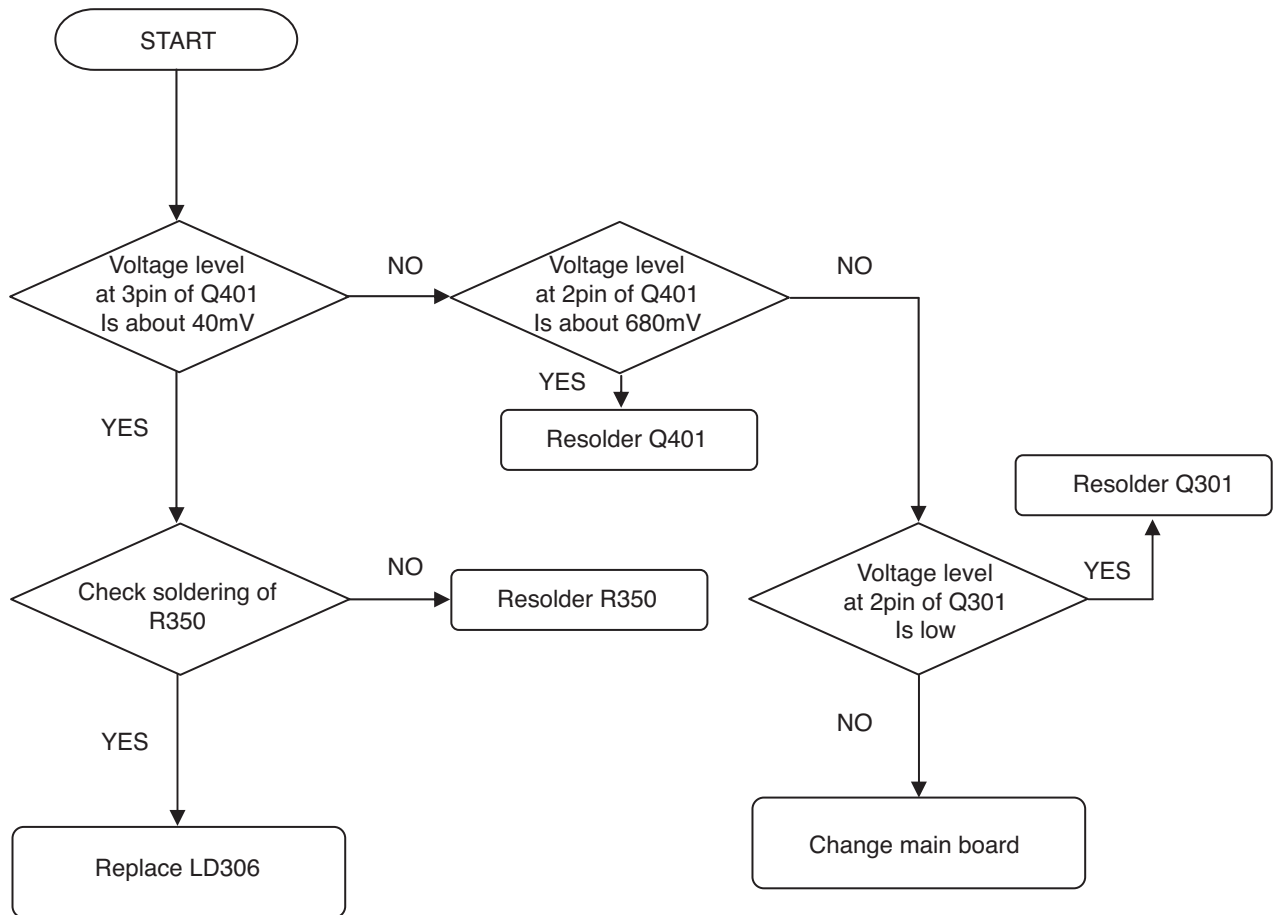

4.16 PTT Trouble

CIRCUIT DIAGRAM

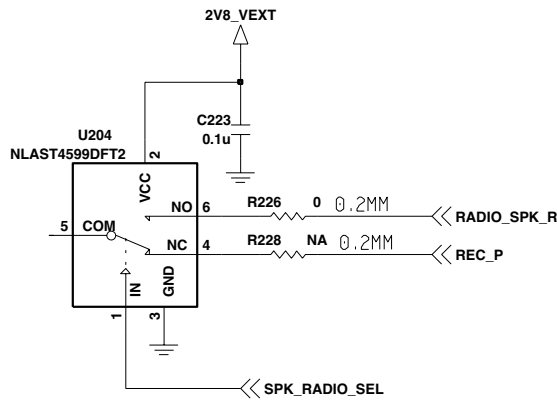

Checking Flow

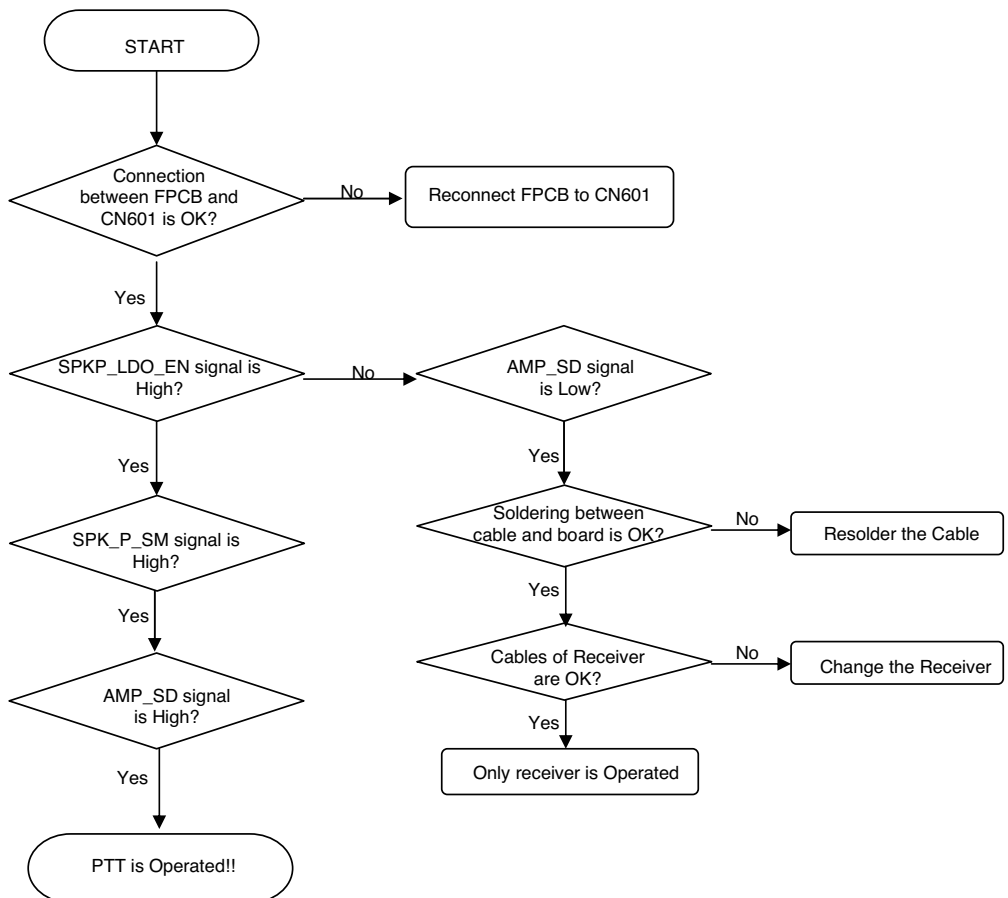

4.17 Speakerphone Trouble

TEST POINT

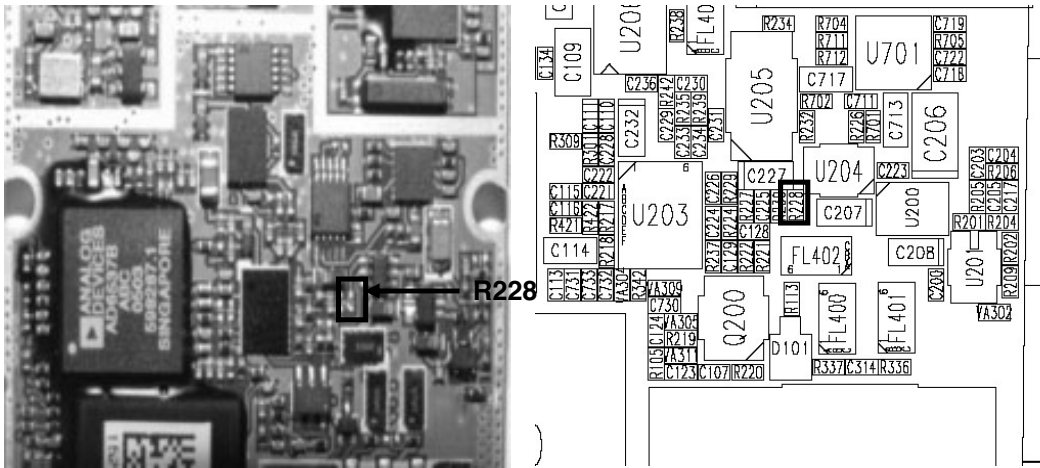

CIRCUIT DIAGRAM

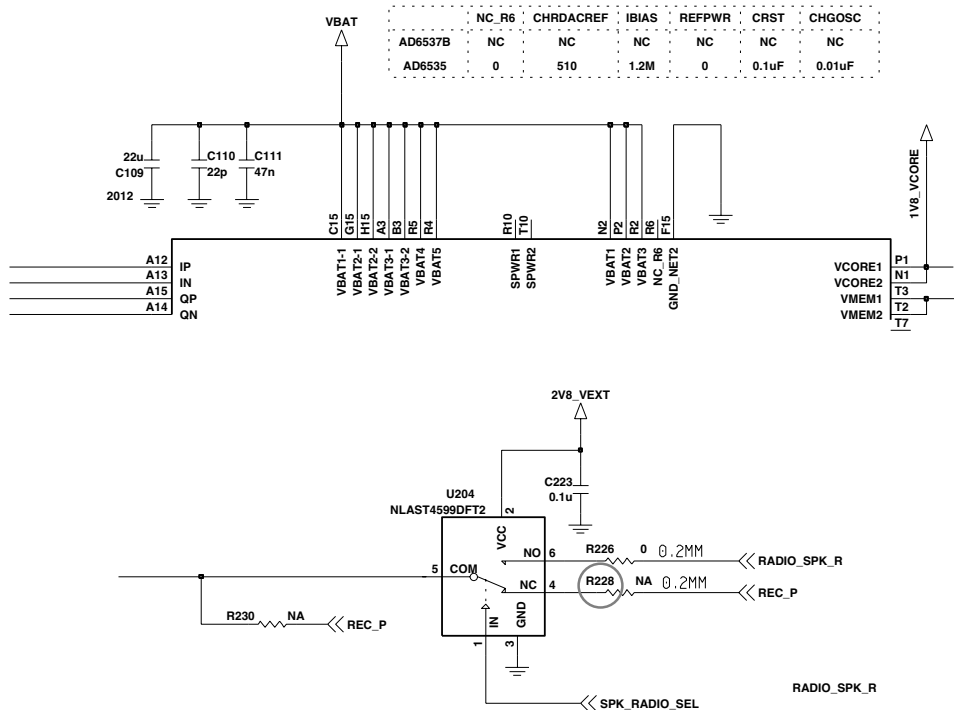

4. TROUBLE SHOOTING

Checking Flow

SETTING: Connect PIF to the phone, and Power on.
Call and enter speakerphone mode

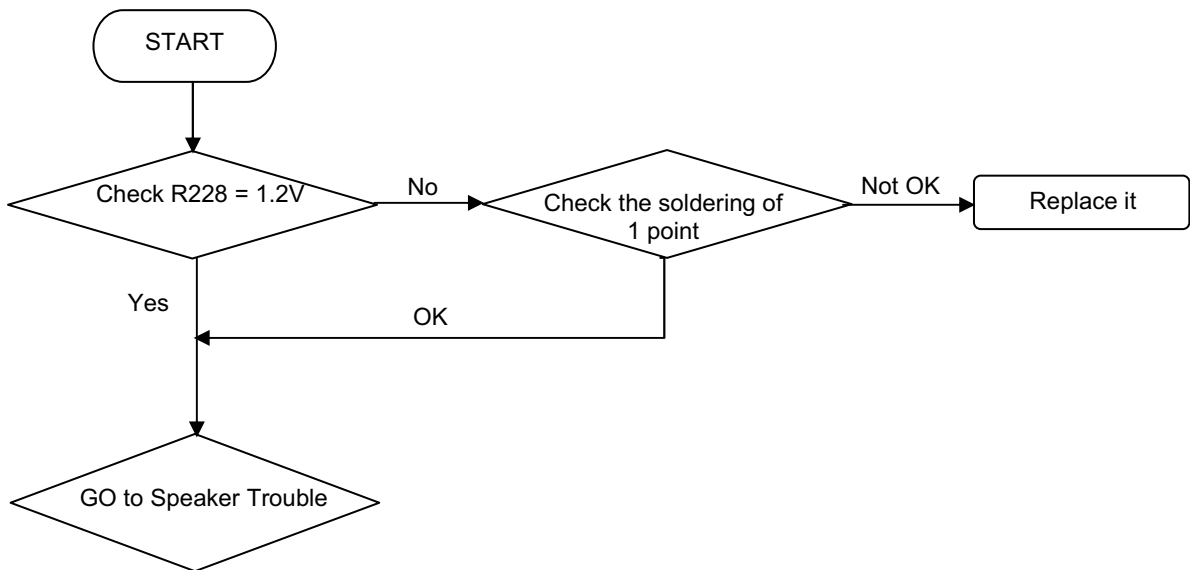

5. DOWNLOAD AND CALIBRATION

5.1 Download

A. Download Setup

Figure 5-1 describes Download setup

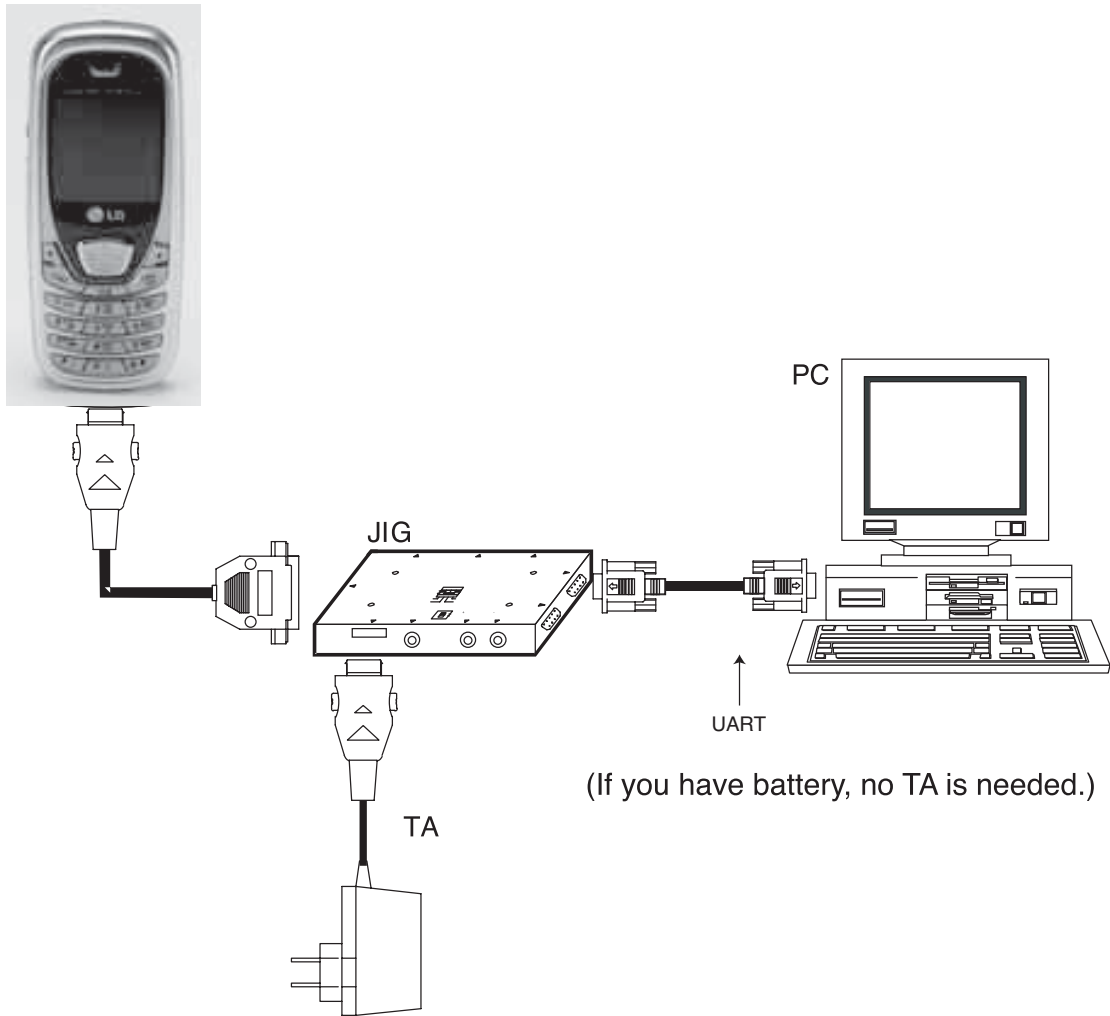
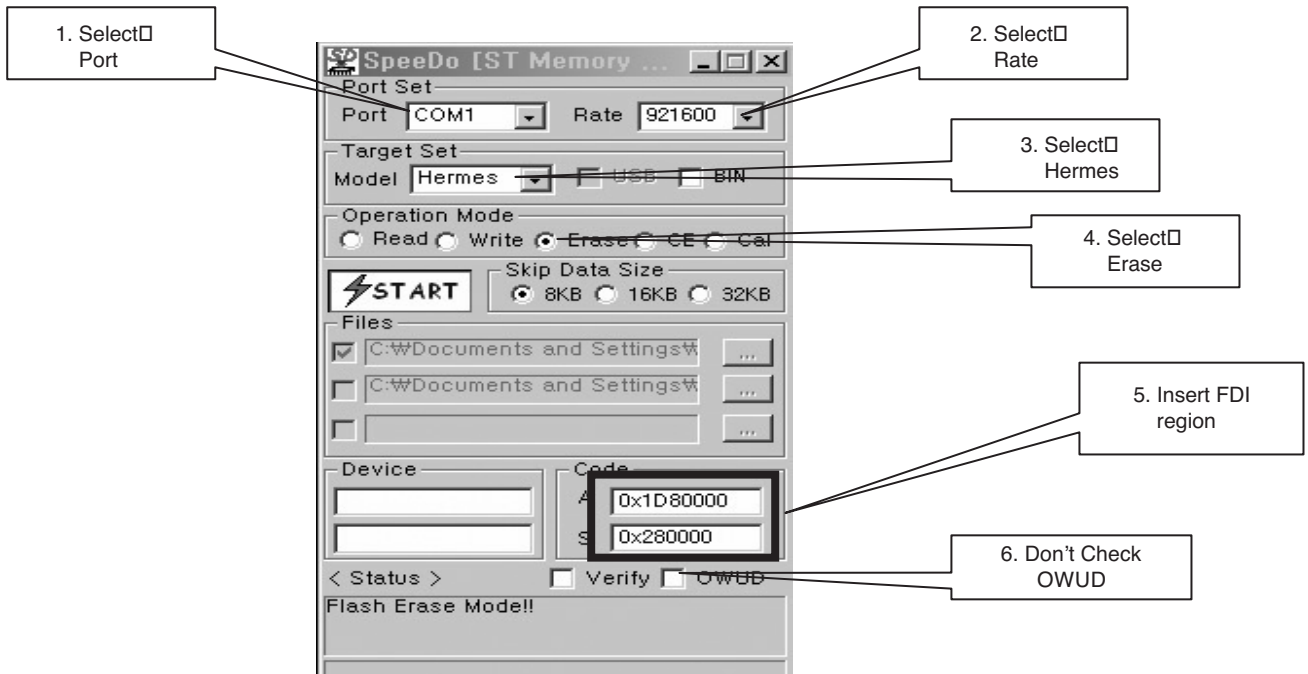

Figure 5-1 DOWNLOAD SETUP

5. DOWNLOAD AND CALIBRATION

B. Download Procedure

1. Access Flash loader program in PC and select Erase(Don't check OWUD).



2. Press Start and Wait until Erase is completed.

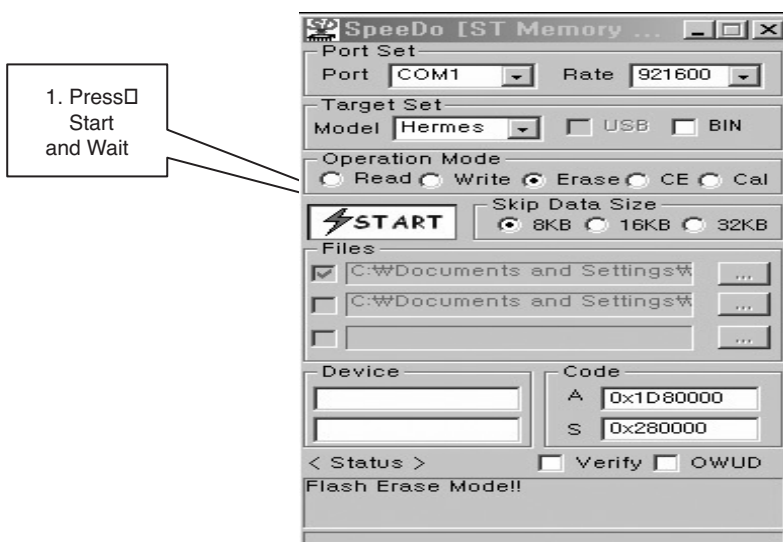

3. Press Write to start Download and press key to choose software (AlchemyDate.mot)

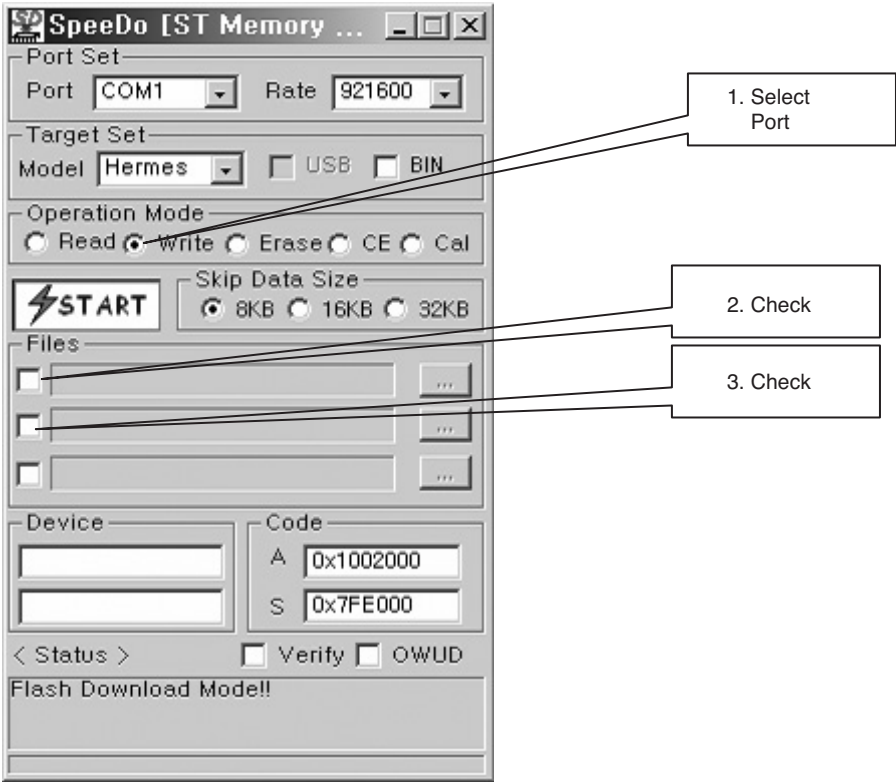

5. DOWNLOAD AND CALIBRATION

4. Choose software

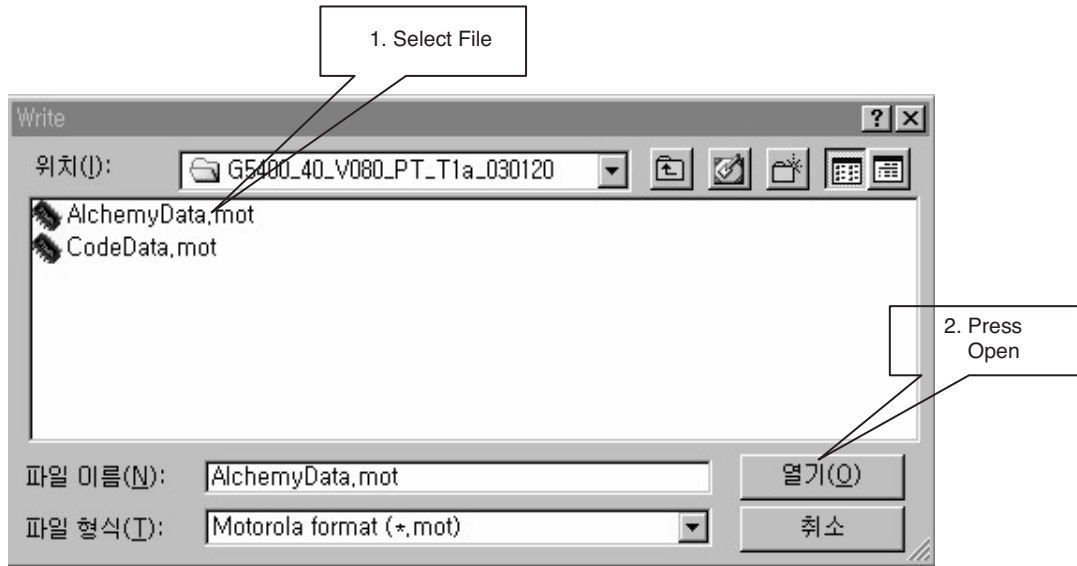

5. Wait until covering from MOT to BIF is completed (Don't check OWUD)

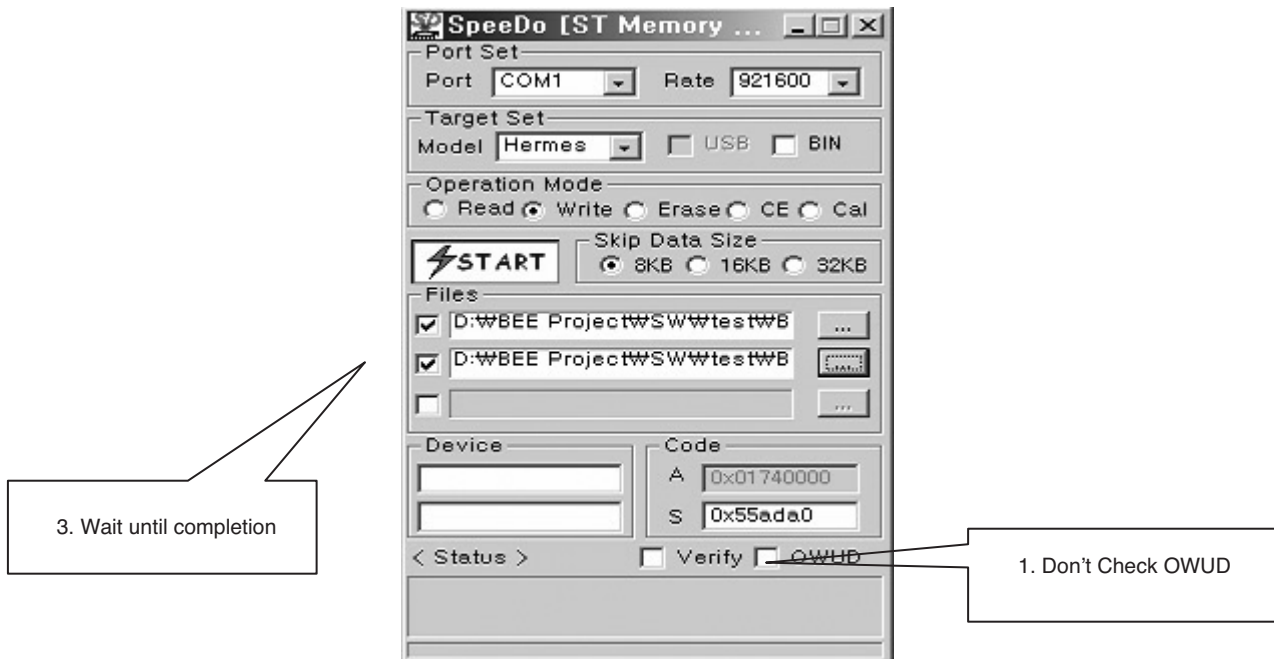

6. Press Start and Pover on the phone using JIG remote Power on (Switch 1)

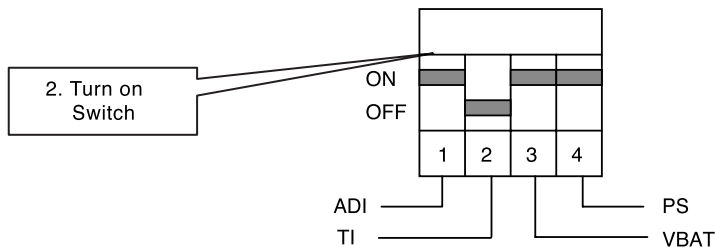
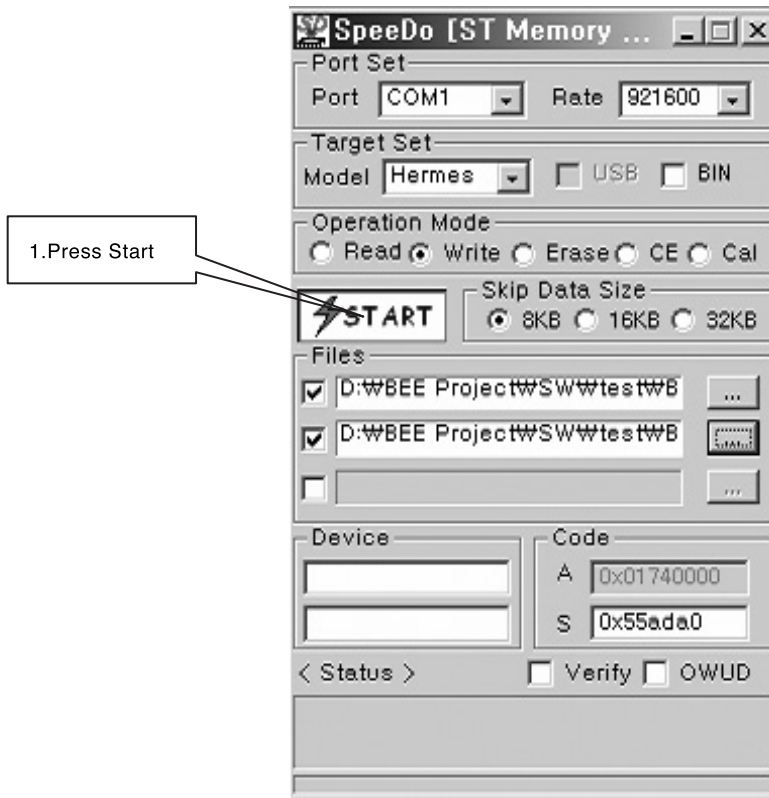

A. Equipment List

Equipment for Calibration	Type/Model	Brand
Wireless Communication Test Set	HP-8960	Agilent
RS-232 Cable and Test JIG		LG
RF Cable		LG
Power Supply	HP-66311B	Agilent
GPIO interface card	HP-GPIB	Agilent
Calibration & Final test software		LG
Test SIM Card		
PC (for Software Installation)	Pentium II class above 300MHz	

Table 5-1 CALIBRATION EQUIPMENT LIST

B. Equipment Setup

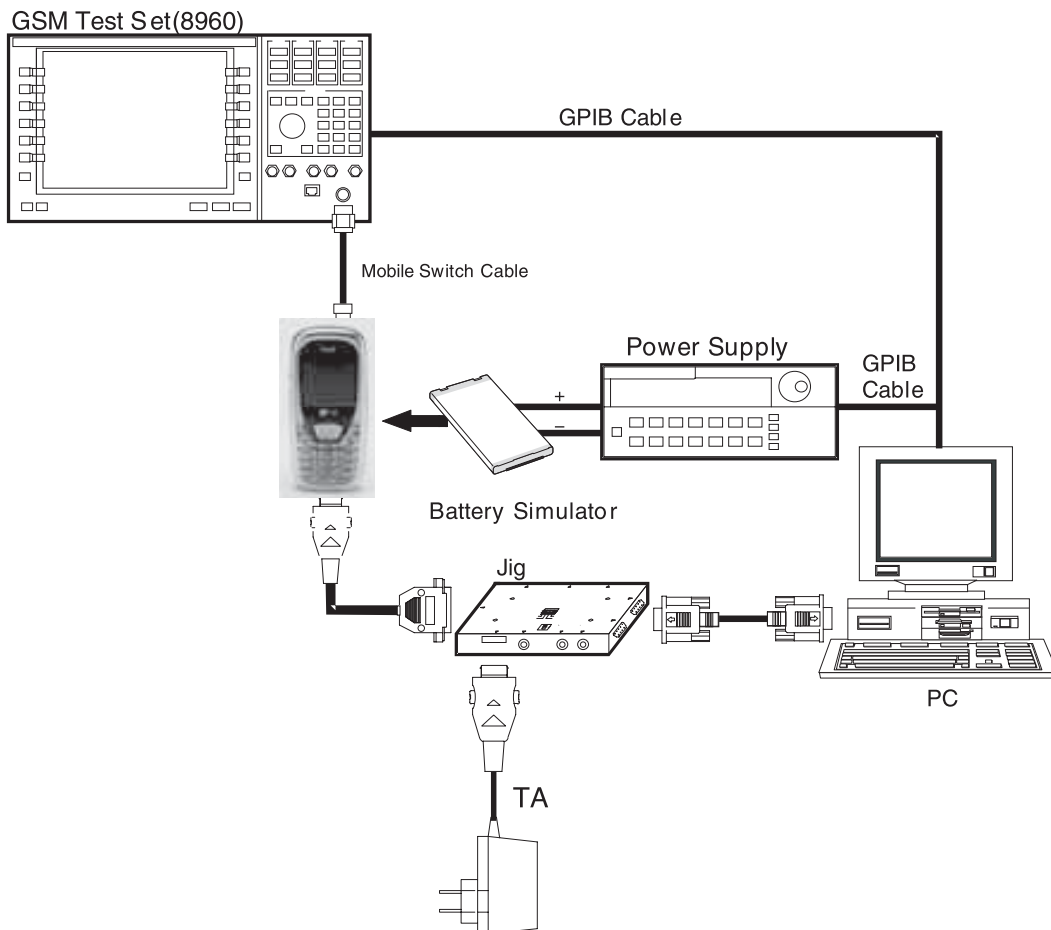

Figure 5-2 EQUIPMENT SETUP

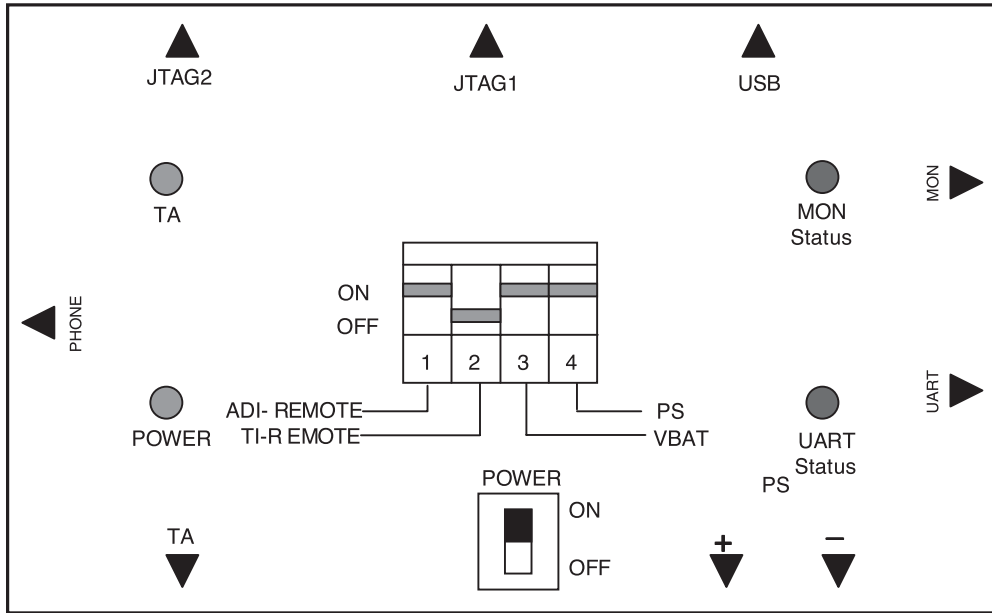

Figure 5-3 THE TOP VIEW OF TEST JIG

C. Test Jig Operation

Power Source	Description
Power Supply	Usually 4.0V
Travel Adaptor	Use TA, name is TA-20G(24pin)

Table 5-2 JIG POWER

Switch Number	Name	Description
Switch 1	ADI-REMOTE	In ON state, phone is awaked. It is used ADI chipset.
Switch 2	TI-REMOTE	In ON state, phone is awaked. It is used TI chipset.
Switch 3	VBAT	Power is provided for phone from battery
Switch 4	PS	Power is provided for phone from Power supply

Table 5-3 JIG DIP SWITCH

LED Number	Name	Description
LED 1	Power	Power is provided for Test Jig.
LED 2	TA	Indicate charging state of the phone battery
LED 3	UART	Indicate data transfer state through the UART port
LED 4	MON	Indicate data transfer state through the MON port

Table 5-4 LED DESCRIPTION

5. DOWNLOAD AND CALIBRATION

1. Connect as Fig 6-2(RS232 serial cable is connected between COM port of PC and MON port of TEST JIG, in general)
2. Set the Power Supply 4.0V
3. Set the 3rd, 4th of DIP SW ON state always
4. Press the Phone power key, if the Remote ON is used, 1st ON state

D. Procedure

1. Connect as Fig 6-2(RS232 serial cable is connected between COM port of PC and MON port of TEST JIG, in general)
2. Power ON PC then enter into Windows 98(Remark : Windows 2000 system could be feasible)
3. Run AUTOCAL.exe, the AUTOCAL application window will be appeared.

6. BLOCK DIAGRAM - Base Band

BEE Project Baseband Block Diagram

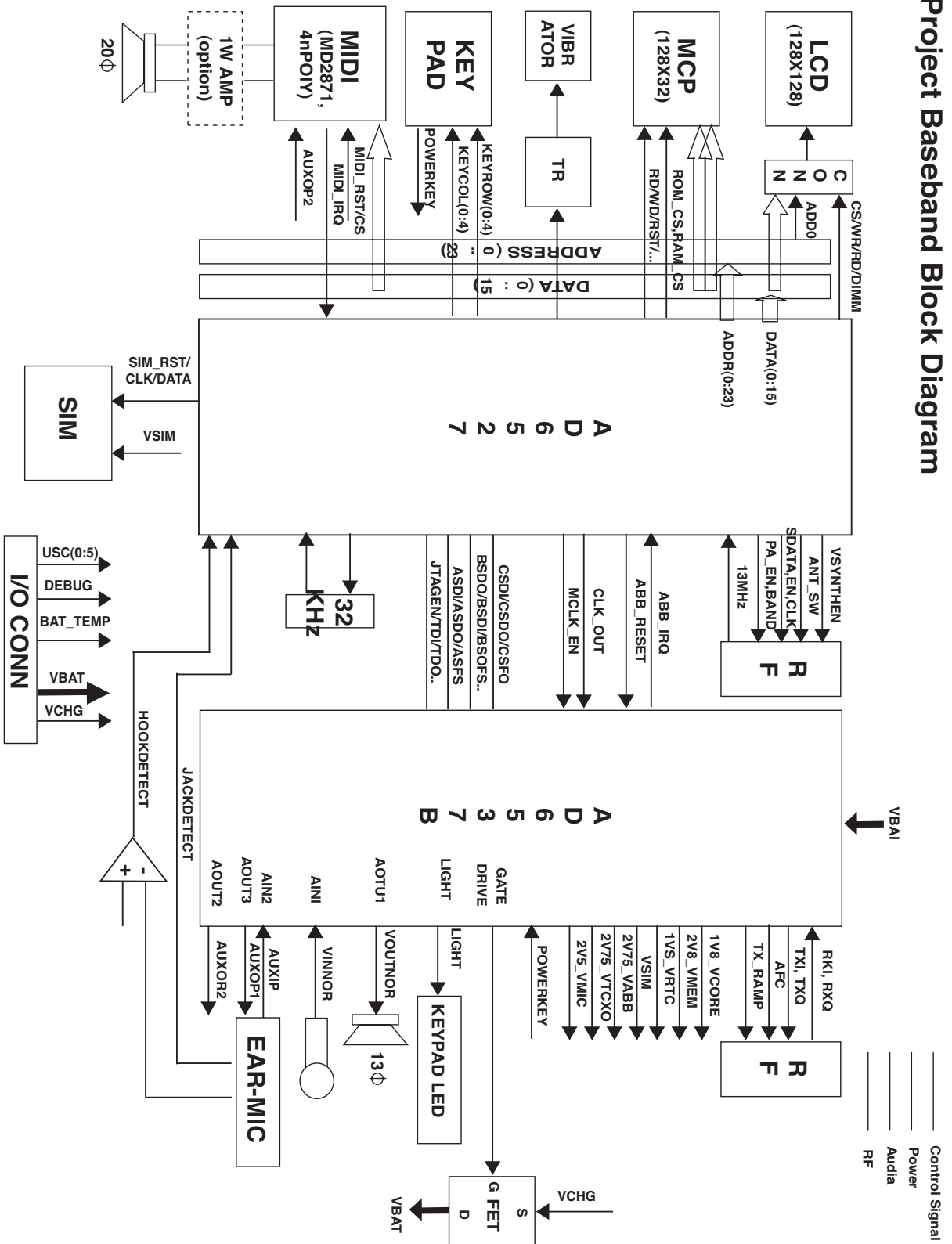

6. BLOCK DIAGRAM - RF

BEE Project RF Block Diagram

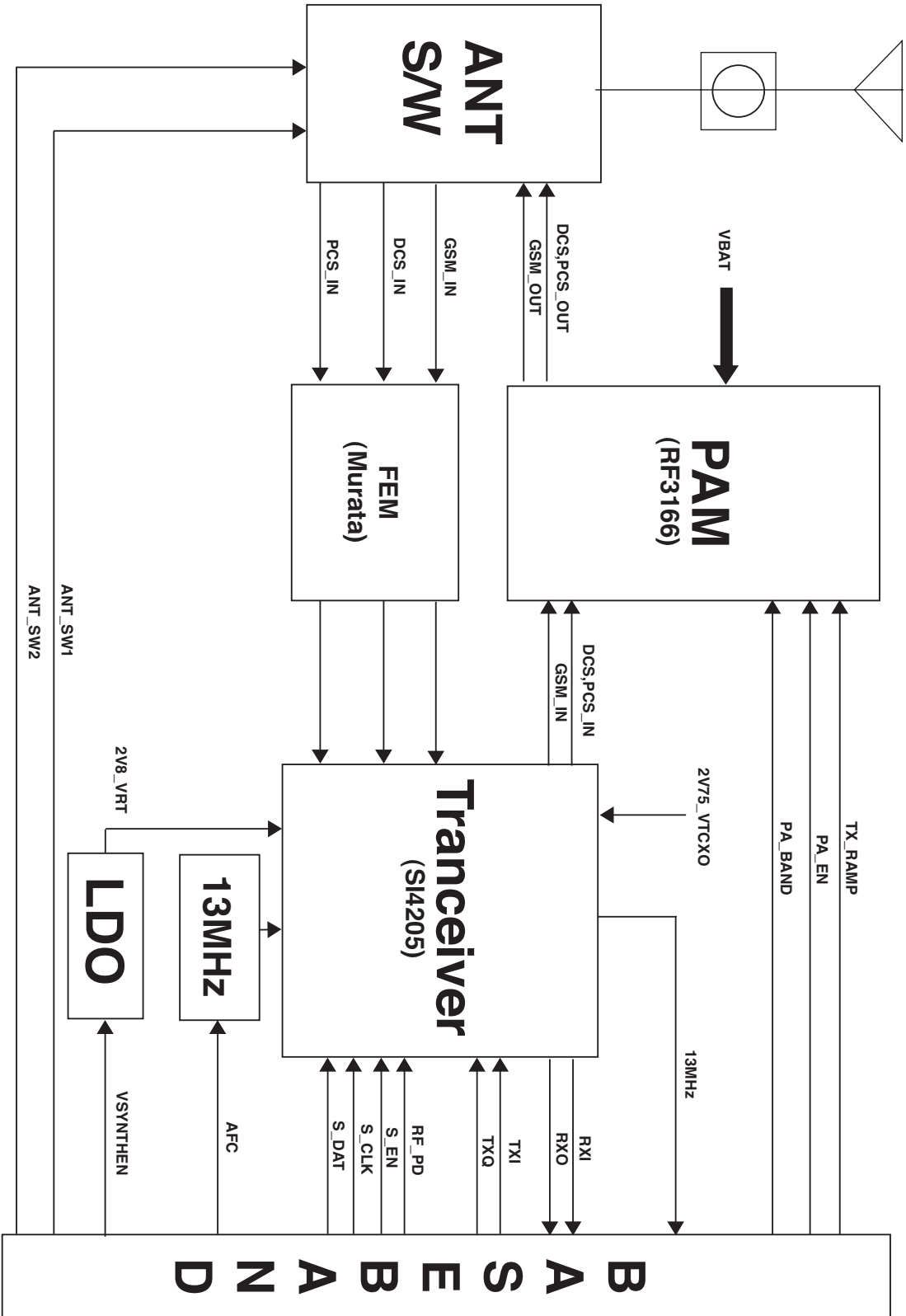

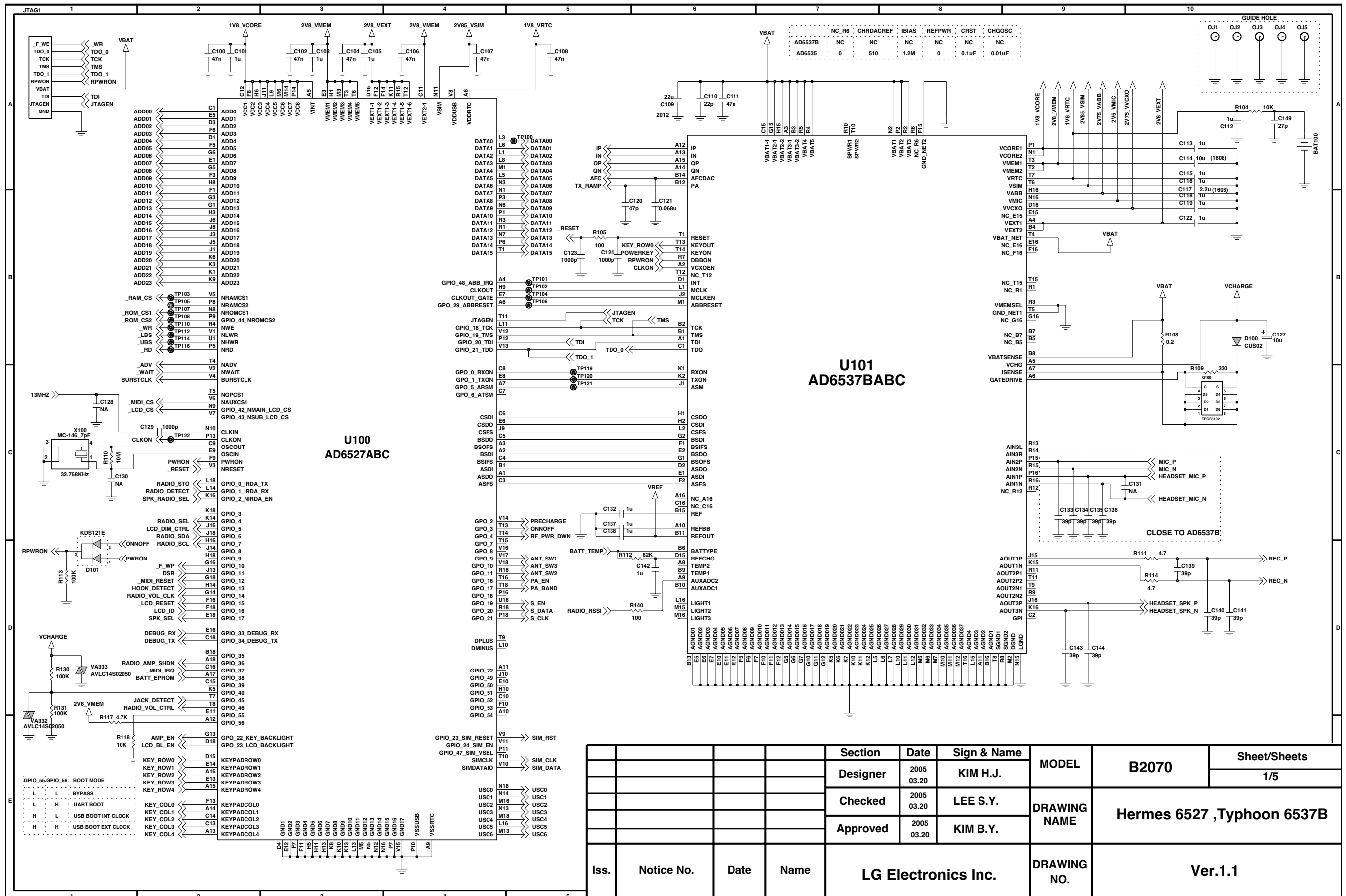

Section	Date	Sign & Name	MODEL	B2070	Sheet/Sheets
Designer	2005 03.20	KIM H.J.	DRAWING NAME	Hermes 6527 ,Typhoon 6537B	1/5
Checked	2005 03.20	LEE S.Y.			
Approved	2005 03.20	KIM B.Y.	DRAWING NO.	Ver.1.1	
Iss.	Notice No.	Date			

7. CIRCUIT DIAGRAM

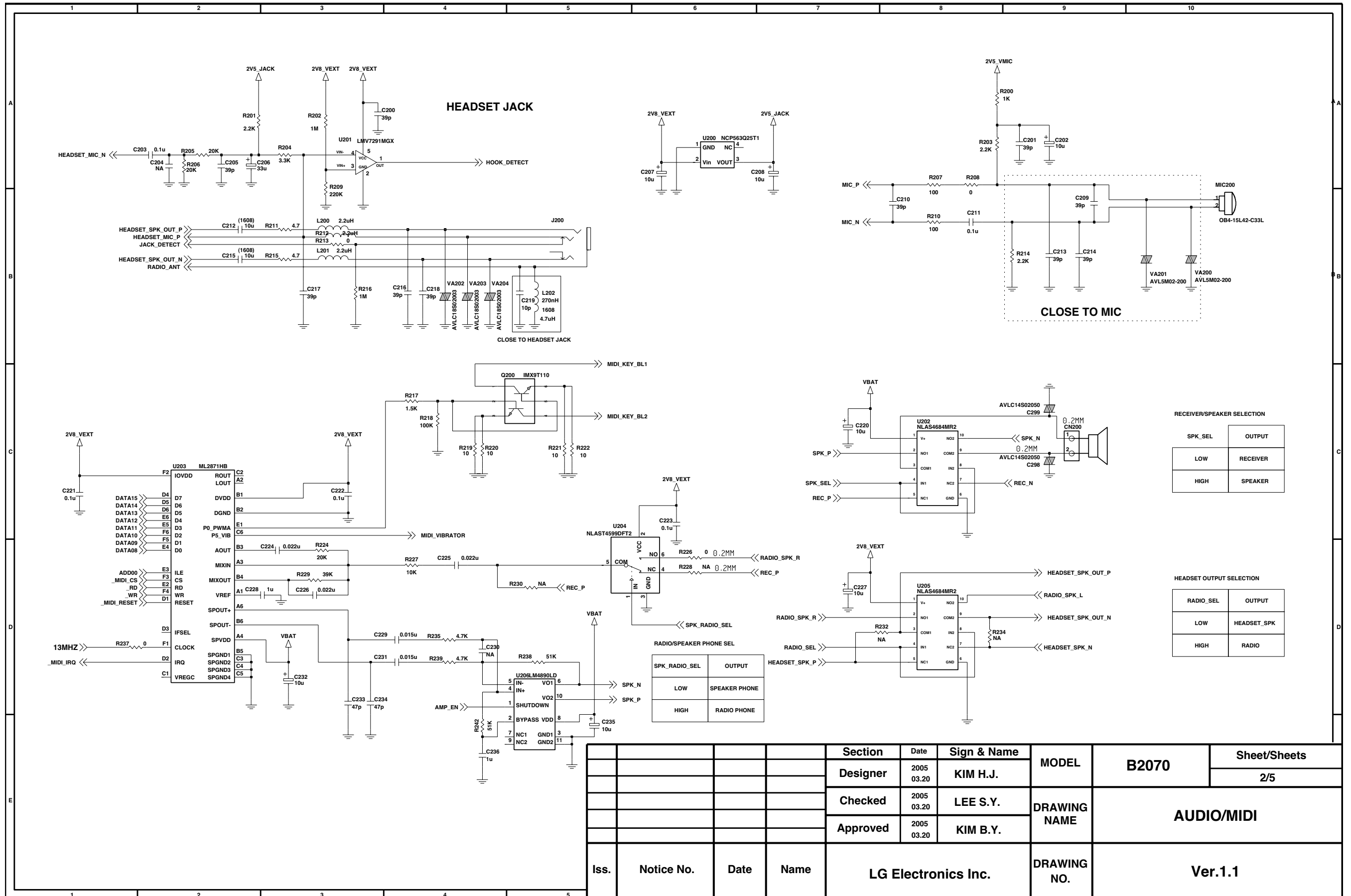

Section	Date	Sign & Name	MODEL	B2070	Sheet/Sheets
Designer	2005 03.20	KIM H.J.			2/5
Checked	2005 03.20	LEE S.Y.	DRAWING NAME	AUDIO/MIDI	
Approved	2005 03.20	KIM B.Y.			
Iss.	Notice No.	Date	Name	LG Electronics Inc.	DRAWING NO.
					Ver.1.1

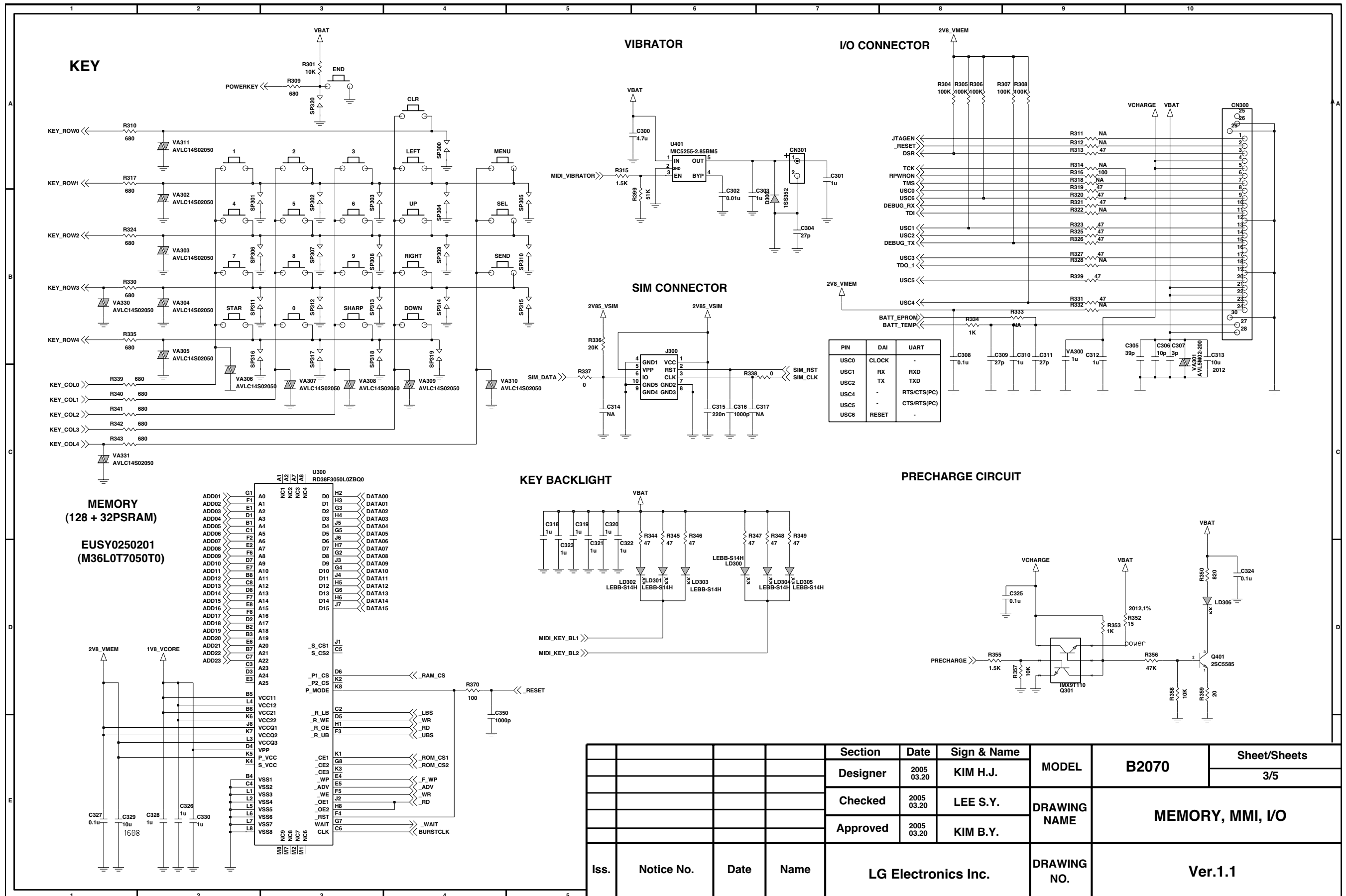

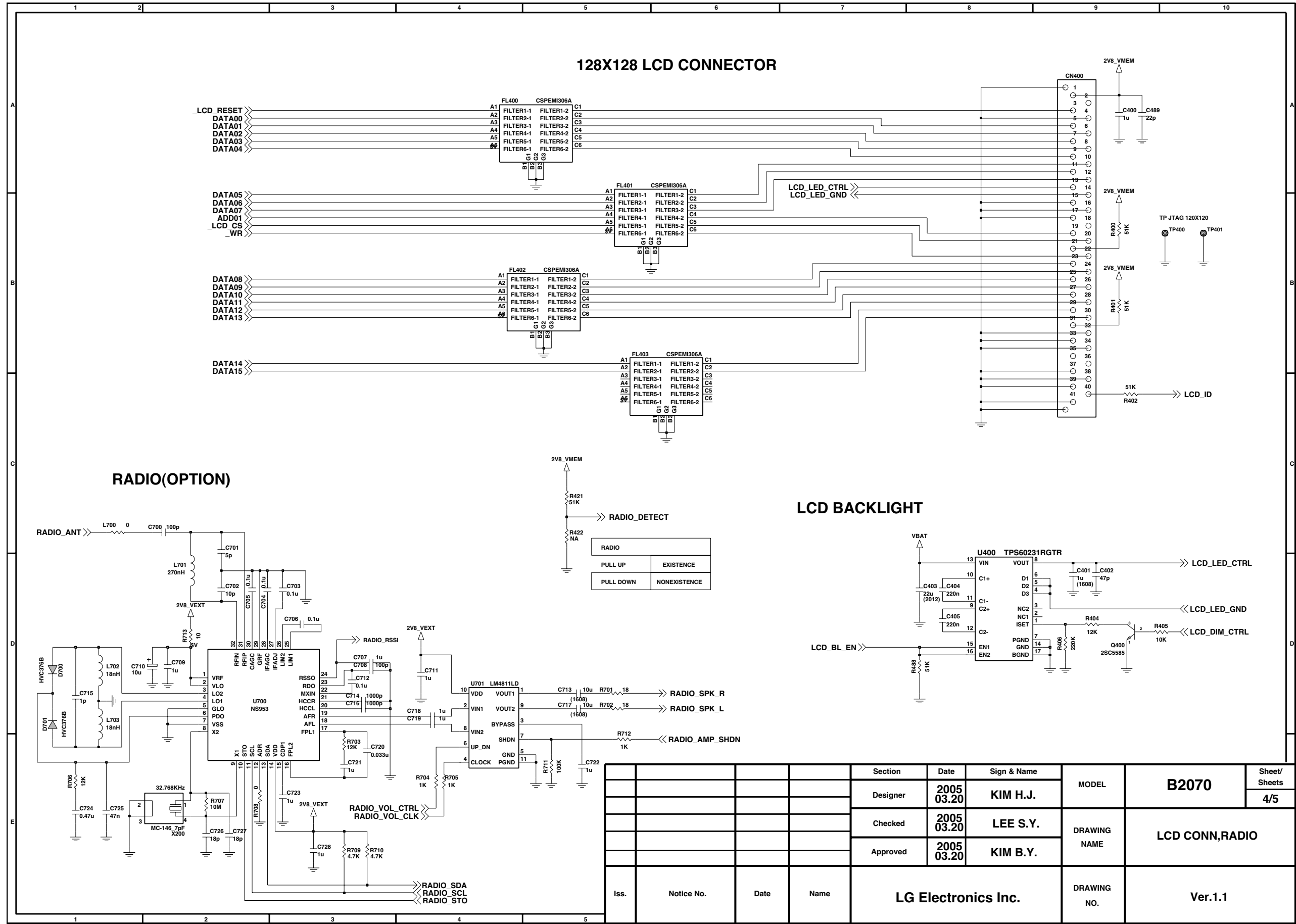

				Section	Date	Sign & Name	MODEL	B2070	Sheet/ Sheets
				Designer	2005 03.20	KIM H.J.			4/5
				Checked	2005 03.20	LEE S.Y.	DRAWING NAME	LCD CONN,RADIO	
				Approved	2005 03.20	KIM B.Y.			
Iss.	Notice No.	Date	Name	LG Electronics Inc.			DRAWING NO.	Ver.1.1	

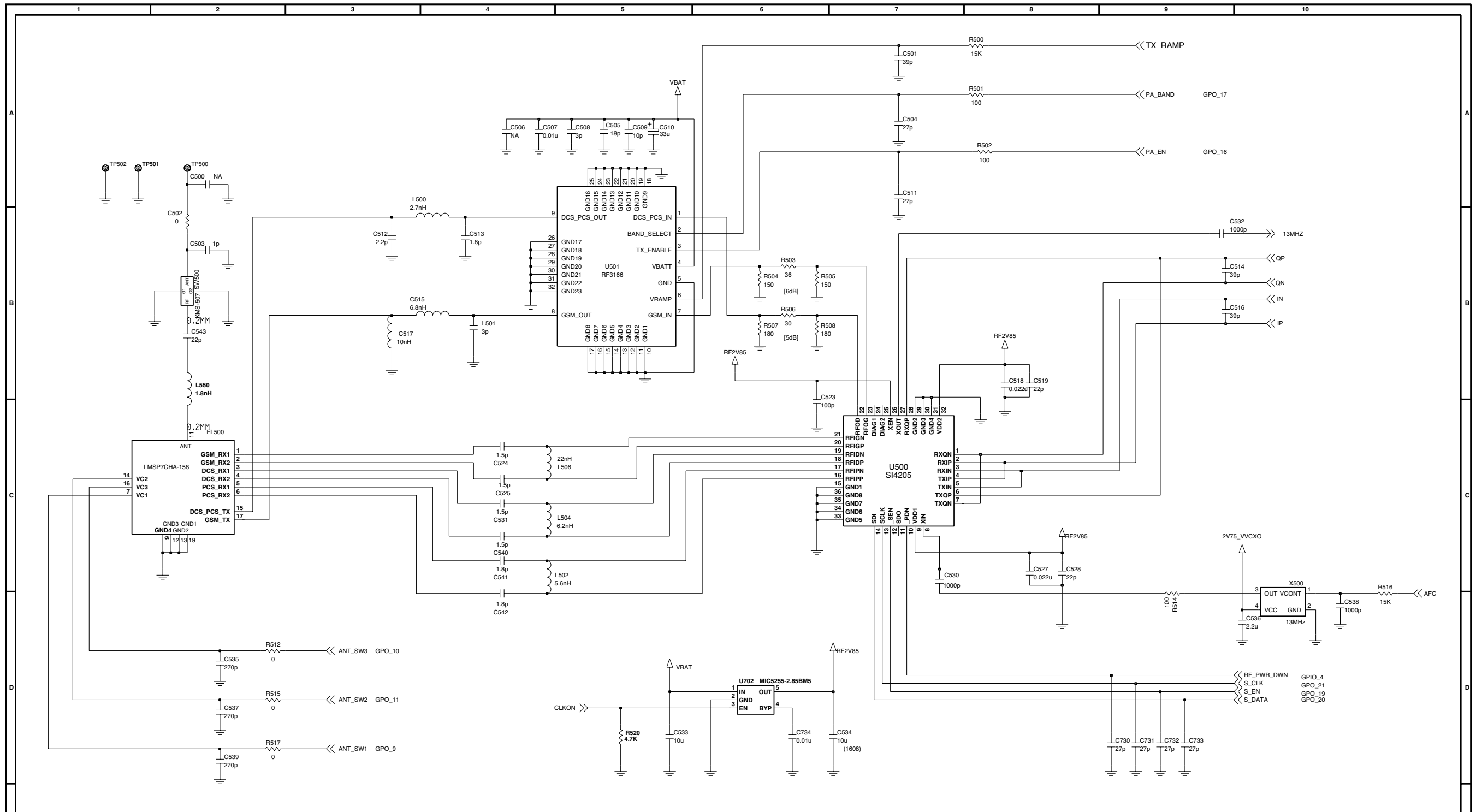

ANT SW CONTROL TABLE

	VC1	VC2	VC3
EGSM_TX	L	L	H
DCS/PCS_TX	L	H	L
EGSM/DCS_RX	L	L	L
PCS_Rx	H	L	L

Section	Date	Sign & Name	MODEL	B2070	Sheet/Sheets
Designer	2005 03.20	KIM Y.G.			5/5
Checked	2005 03.20	LEE S.Y.	DRAWING NAME	RF	
Approved	2005 03.20	KIM B.Y.			
Iss.	Notice No.	Date	Name	DRAWING NO.	Ver.1.1
LG Electronics Inc.					

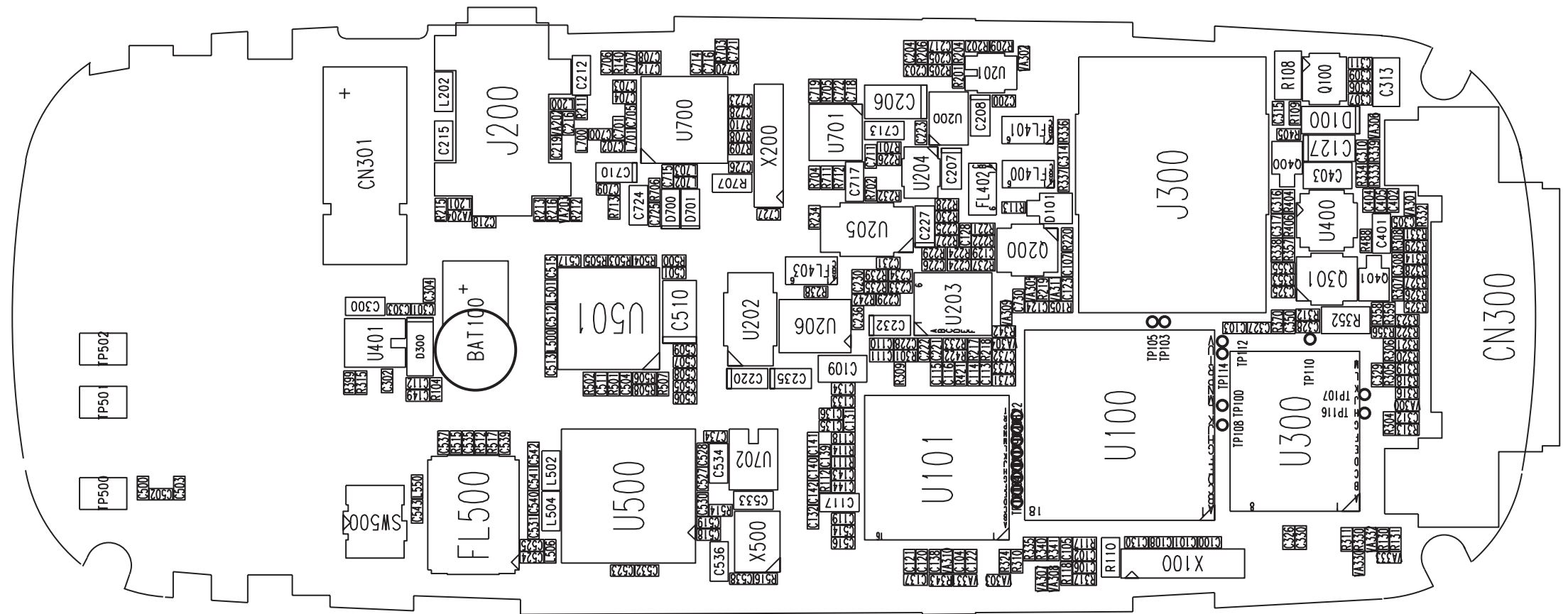

Figure 8-1 B2070 BOTTOM SIDE PCB LAYOUT

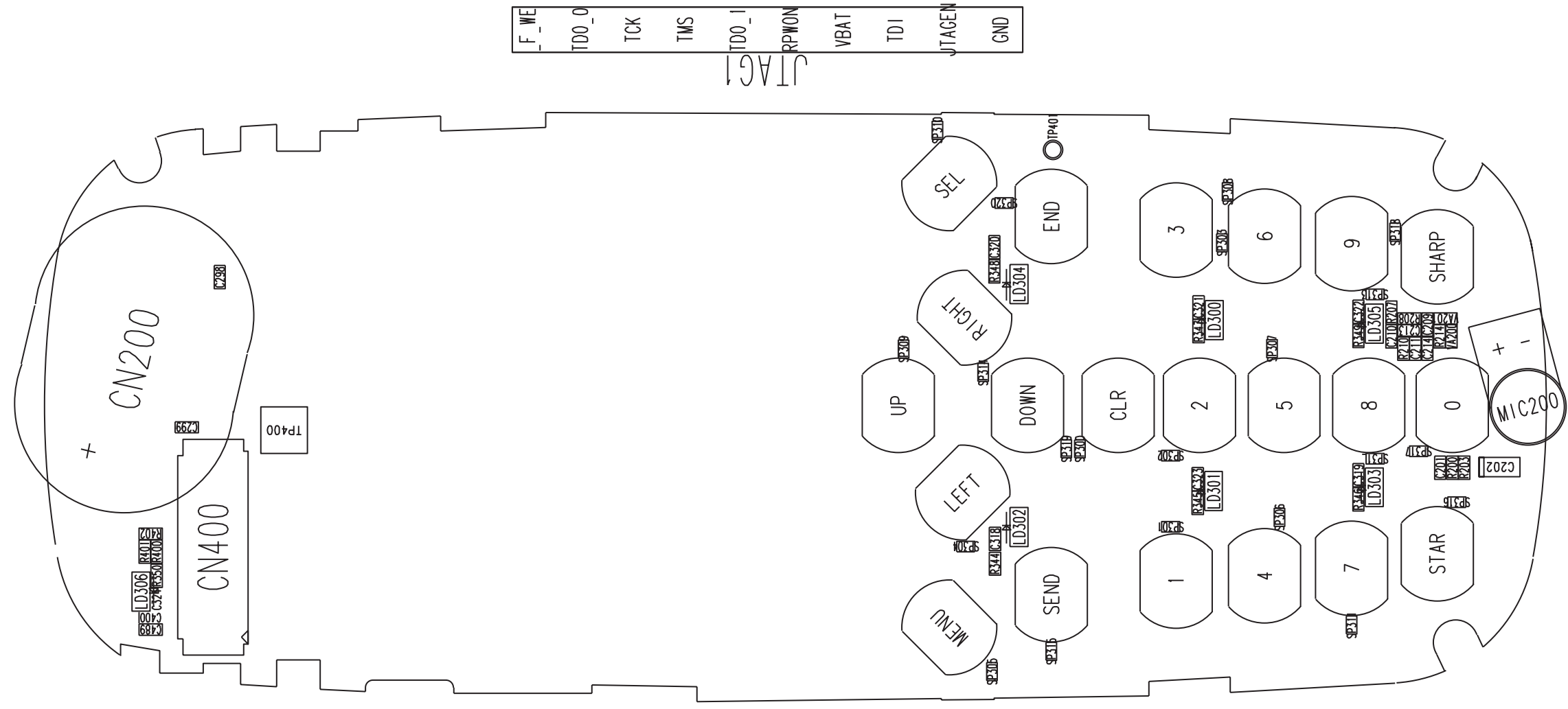

Figure 8-1 B2070 TOP SIDE PCB LAYOUT

9. ENGINEERING MODE

A. About Engineering Mode

Engineering mode is designed to allow a service man/engineer to view and test the basic functions provided by a handset.

B. Access Codes

The key sequence for switching the engineering mode on is 2945#*#. Pressing END will switch back to non-engineering mode operation.

C. Key Operation

Use Up and Down key to select a menu and press 'select' key to progress the test. Pressing 'back' key will switch back to the original test menu.

D. Engineering Mode Menu Tree

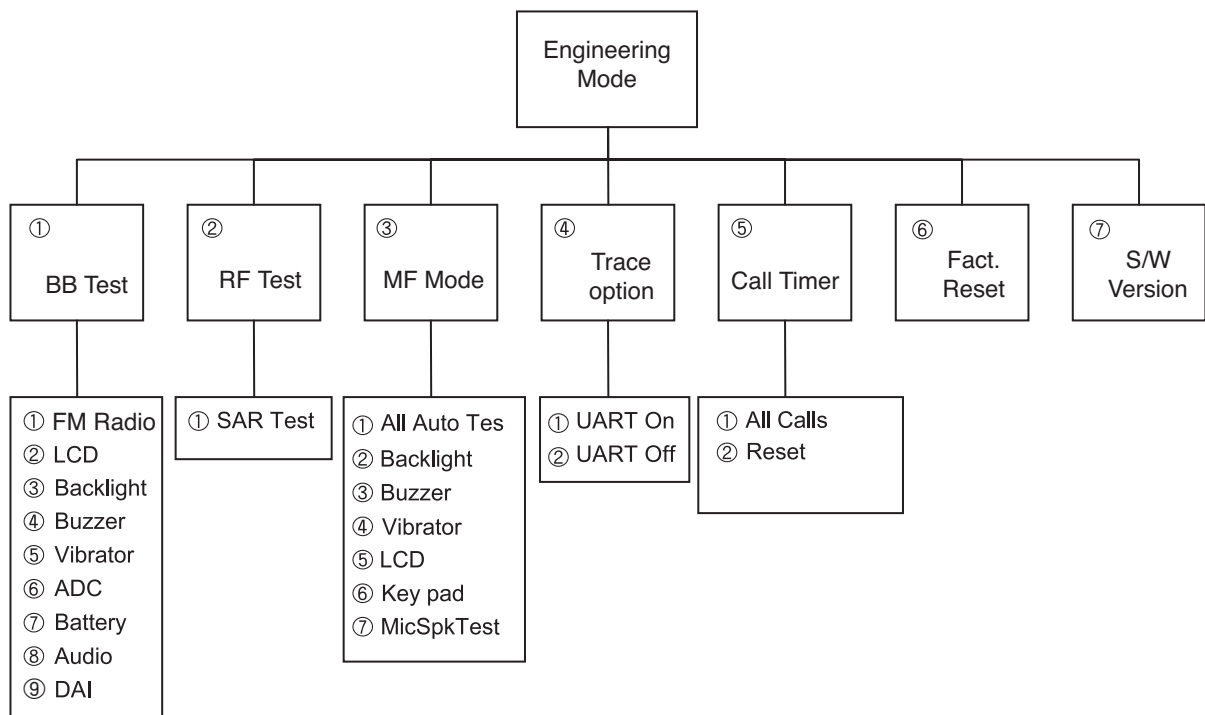

9.1 BB Test [MENU 1]

9.1.1 FM Radio

- 1) **Listen Radio** : This menu is to used for listening FM Radio.(It must be connected Earphone.)
- 2) **Test ON**
- 3) **Test OFF**

9.1.2 LCD

- 1) **Contrast value** : This menu is to input Contrast Value of the LCD.
- 2) **Test ON**
- 3) **Test OFF**

9.1.3 Backlight

This menu is to test the LCD Backlight and Keypad Backlight.

- 1) **Backlight on** : LCD Backlight and Keypad Backlight light on at the same time.
- 2) **Backlight off** : LCD Backlight and Keypad Backlight light off at the same time.
- 3) **Backlight value** : This controls brightness of Backlight. When entering into the menu,the present backlight-value in the phone is displayed. Use Left/Right key to adjust the level of brightness. The value of the brightness set at last will besaved in the NVRAM.

9.1.4 Buzzer

This menu is to test the melody sound.

- 1) **Melody on** : Melody sound is played through the speaker.
- 2) **Melody off** : Melody sound is off.

9.1.5 Vibrator

This menu is to test the vibration mode.

- 1) **Vibrator on** : Vibration mode is on.
- 2) **Vibrator off** : Vibration mode is off.

9.1.6 ADC (Analog to Digital Converter)

This displays the value of each ADC.

- 1) **MVBAT ADC** : Main Voltage Battery ADC
- 2) **AUX ADC** : Auxiliary ADC
- 3) **TEMPER ADC** : Temperature ADC

9.1.7 BATTERY

1) **Bat Cal** : This displays the value of Battery Calibration. The following menus are displayed in order : BAT_LEV_4V, BAT_LEV_3_LIMIT, BAT_LEV_2_LIMIT, BAT_LEV_1_LIMIT, BAT_IDLE_LIMIT, BAT_INCALL_LIMIT, SHUT_DOWN_VOLTAGE, BAT_RECHARGE_LMT

2) **TEMP Cal** : This displays the value of Temperature Calibration. The following menus are displayed in order : TEMP_HIGH_LIMIT, TEMP_HIGH_RECHARGE_LMT, TEMP_LOW_RECHARGE_LMT, TEMP_LOW_LIMIT

9.1.8 Audio

This is a menu for setting the control register of Voiceband Baseband Codec chip. Although the actual value can be written over, it returns to default value after switching off and on the phone.

- 1) **VbControl1** : VbControl1 bit Register Value Setting
- 2) **VbControl2** : VbControl2 bit Register Value Setting
- 3) **VbControl3** : VbControl3 bit Register Value Setting
- 4) **VbControl4** : VbControl4 bit Register Value Setting
- 5) **VbControl5** : VbControl5 bit Register Value Setting
- 6) **VbControl6** : VbControl6 bit Register Value Setting

9.1.9 DAI (Digital Audio Interface)

This menu is to set the Digital Audio Interface Mode for Speech Transcoder and Acoustic testing.

- 1) **DAI AUDIO** : DAI audio mode
- 2) **DAI UPLINK** : Speech encoder test
- 3) **DAI DOWNLINK** : Speech decoder test
- 4) **DAI OFF** : DAI mode off

9.2 RF Test [MENU 2]

9.2.1 SAR test

This menu is to test the Specific Absorption Rate.

- 1) **SAR test on** : Phone continuously process TX only.
Call-setup equipment is not required.
- 2) **SAR test off** : TX process off

9.3 MF mode [MENU 3]

This manufacturing mode is designed to do the baseband test automatically. Selecting this menu will process the test automatically, and phone displays the previous menu after completing the test.

9.3.1 All auto test

LCD, Backlight, Vibrator, Buzzer, Key Pad, Mic&Speaker,

9.3.2 Backlight

LCD Backlight is on for about 1.5 seconds at the same time, then off.

9.3.3 Buzzer

This menu is to test the volume of Melody. It rings in the following sequence. Volume 1, Volume 2, Volume 3, Volume 0 (mute), Volume 4, Volume 5.

9.3.4 Vibrator

Vibrator is on for about 1.5 seconds.

9.3.5 LCD

1) LCD

Main LCD screen resolution tests horizontally and vertically one by one and fills the screen.

9.3.6 Key pad

When a pop-up message shows 'Press Any Key', you may press any keys including side keys, but not [Soft2 Key]. If the key is working properly, name of the key is displayed on the screen. Test will be completed in 15 seconds automatically.

9.3.7 MicSpkTest

The sound from MIC is recorded for about 3 seconds, then it is replayed on the speaker automatically.

9.4 Trace option [MENU 4]

This is NOT a necessary menu to be used by neither engineers nor users.

9.5 Call timer [MENU 5]

This menu is to set the Digital Audio Interface Mode for Speech Transcoder and Acoustic testing.

- 1) **All calls** : This displays total conversation time. User cannot reset this value.
- 2) **Reset settings** : This resets total conversation time to this,[00:00:00].
- 3) **DAI DOWNLINK** : Speech decoder test
- 4) **DAI OFF** : DAI mode off

9.6 Fact. Reset [MENU 6]

This Factory Reset menu is to format data block in the flash memory and this procedure set up the default value in data block.

Attention

- ① Fact. Reset (i.e.Factory Reset) should be only used during the Manufacturing process.
- ② Servicemen should NOT progress this menu, otherwise some of valuable data such as Setting value, RF Calibration data, etc. cannot be restored again.

9.7 S/W version [MENU 7]

This displays software version stored in the phone.

10. STAND ALONE TEST

10.1 Introduction

This manual explains how to examine the status of RX and TX of the model.

A. Tx Test

TX test - this is to see if the transmitter of the phones is activating normally.

B. Rx Test

RX test - this is to see if the receiver of the phones is activating normally.

10.2 Setting Method

A. COM port

- a. Move your mouse on the "Connect" button, then click the right button of the mouse and select "Com setting".
- b. In the "Dialog Menu", select the values as explained below.
 - Port : select a correct COM port
 - Baud rate : 38400
 - Leave the rest as default values

B. Tx

1. Selecting Channel

- Select one of GSM or DCS Band and input appropriate channel.

2. Selecting APC

- a. Select either Power level or Scaling Factor.
- b. Power level
 - Input appropriate value GSM (between 5~19) or DCS (between 0~15)
- c. Scaling Factor
 - A 'Ramp Factor' appears on the screen.
 - You may adjust the shape of the Ramp or directly input the values.

C. Rx

1. Selecting Channel

- Select one of GSM or DCS Band and input appropriate channel.

2. Gain Control Index (0~ 26) and RSSI level

- See if the value of RSSI is close to - 16dBm when setting the value between 0 ~ 26 in Gain Control Index.
- Normal phone should indicate the value of RSSI close to - 16dBm.

10.3 Means of Test

- a. Select a COM port
- b. Set the values in Tx or Rx
- c. Select band and channel
- d. After setting them all above, press connect button.
- e. Press the start button

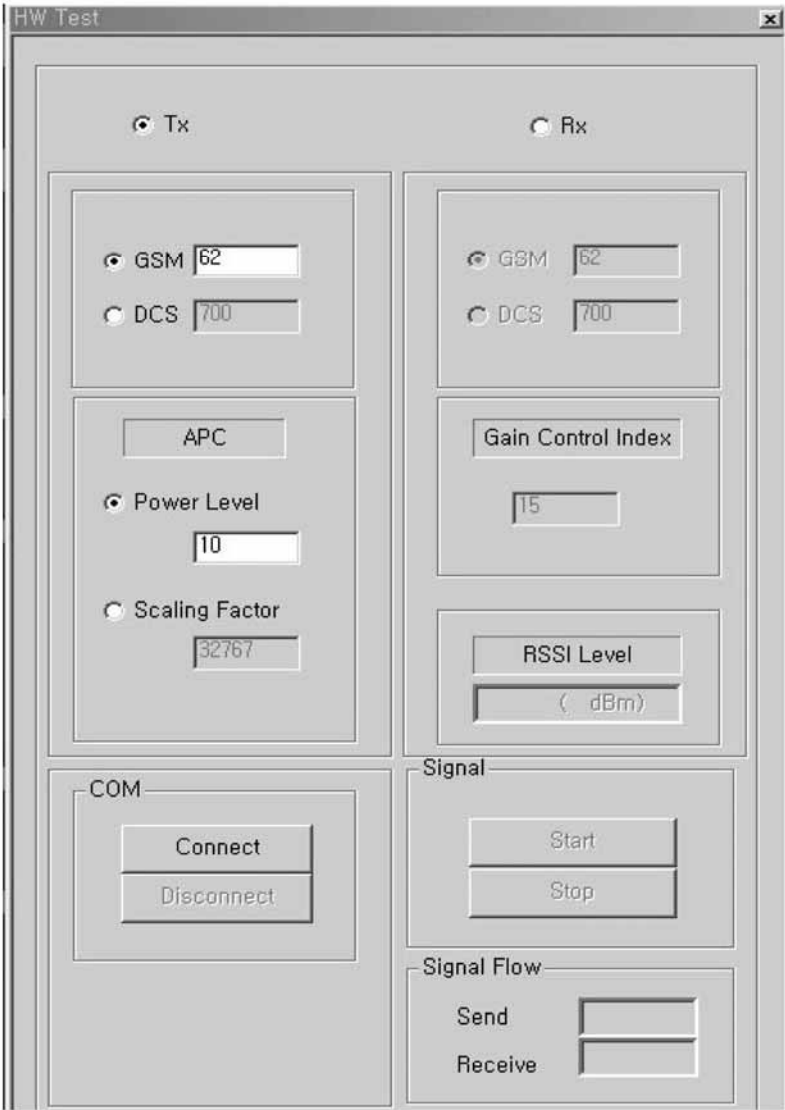

Figure 10-1. HW test program

10. STAND ALONE TEST

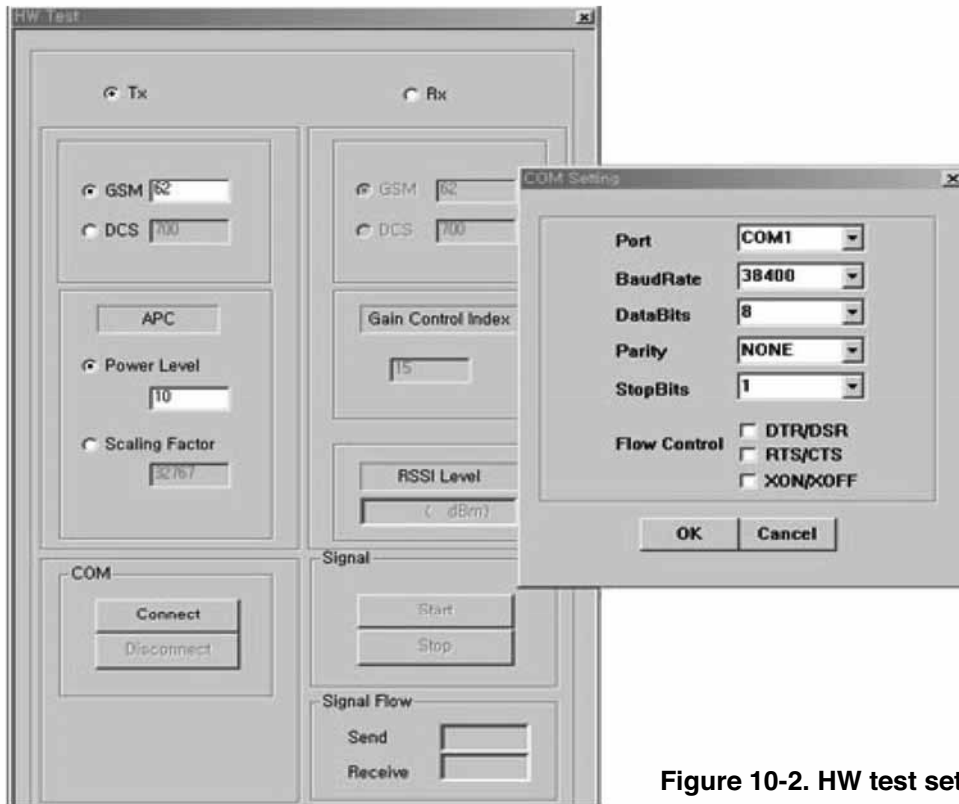

Figure 10-2. HW test setting

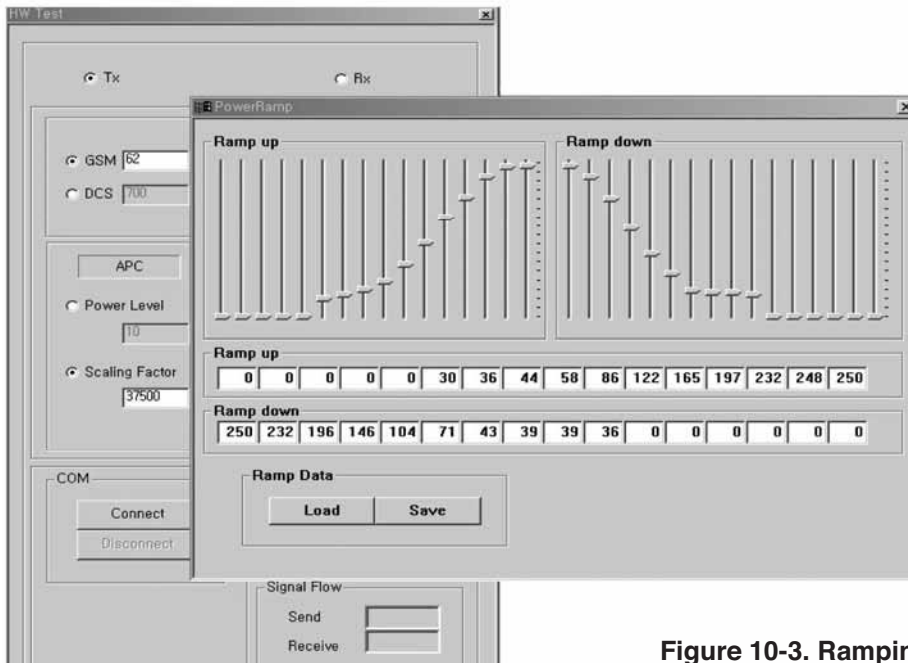

Figure 10-3. Ramping profile

11. AUTO CALIBRATION

11.1 Overview

Autocal(Auto Calibration) is the PC side Calibration tool that perform Tx, Rx and Battery Calibration with Agilent 8960(GSM call setting instrument) and Tektronix PS2521G(Programmable Power supply).

Autocal generate calibration data by communicating with phone and measuring equipment then write it into calibration data block of flash memory in GSM phone.

11.2 Requirements

- PC or Notebook installed with Microsoft Windows 98/ME/2000/XP
- Auto Calibration program(Autocal.exe)
- GSM Phone
- LGE PIF JIG, Serial Cable, Data Cable
- Agilent 8960(Call Setting Instrument)
- Tektronix PS2521G(Programmable Power Supply)

11.3 Menu and Settings

- File(F) Clear View : Clear Calibration Status window texts
- File(F) Save View : Save Calibration Status window texts
- File(F) Save Setting : Save Current Calibration settings to setting file(*.cal)
- File(F) Load Setting : Load saved Calibration setting
- File(F) Make BIN ALL : Make binary file after calibration finished
- File(F) Make BIN BAT.Cal only : Make binary file of battery cal data only after calibration finished
- File(F) Make & Write BIN : Make binary file after calibration finished then download it to the Flash Memory
- View(V) Tools : Enable or disable Tool bar
- View(V) Status : Enable or disable status bar
- Connection(C) Connect : Connect the phone with PC. This procedure checks whether the PC is connected "ag8960" or not. After that it performs sync. procedure withphone. If the sync. procedure is successful state column on status bar changed to SETUP, else you should disconnect phone and try again from the beginning and also check the whole connection. All measurement is performed at state SETUP.
- Connection(C) Port Setting : Show COM port setting dialog and Baudrate you can change, etc.
- GPIB(G) Connect : Connect the Ag8960 GPIB card with PC.

11. AUTO CALIBRATION

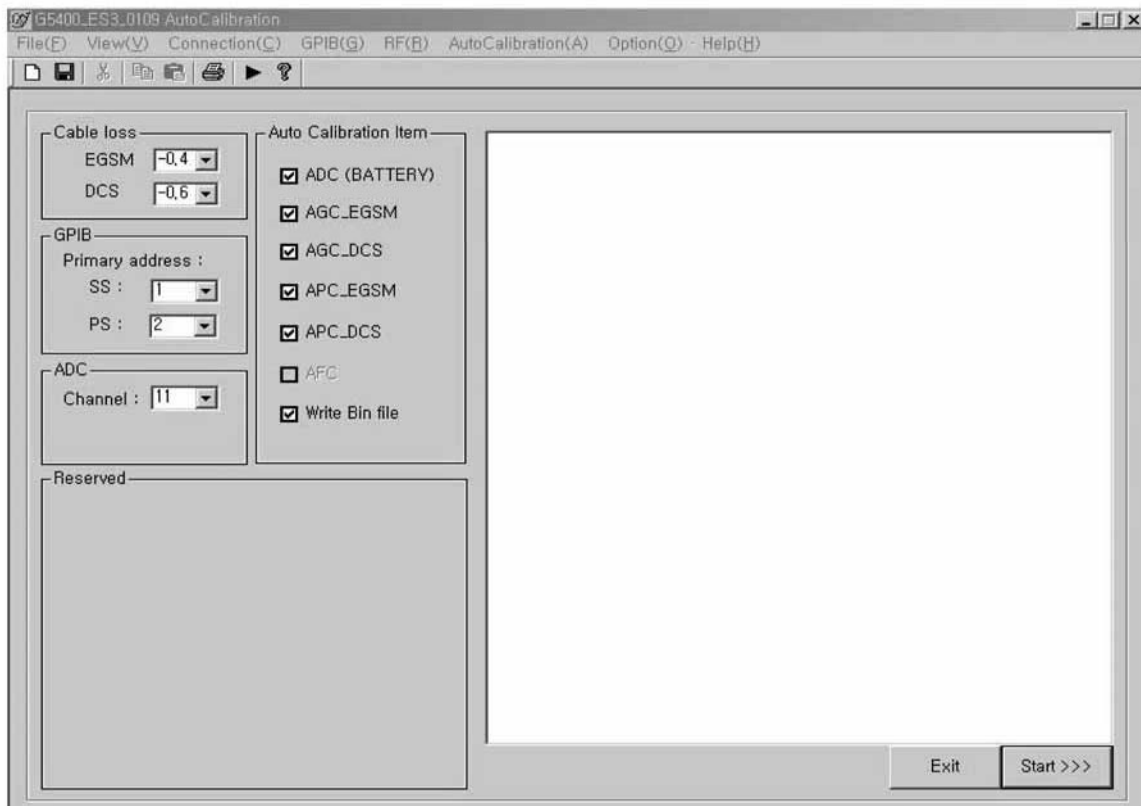

Figure 11-1 Auto Calibration Program

- Screen → Cable loss : Enter the RF cable loss GSM and DCS
- Screen → GPIB(Primary address) : Enter the SS(Ag8960) and PS(Tektronix PS2521G) GPIB address
- Screen → ADC Channel : Default ADC Calibration Channel
- Screen → Auto Calibration Item : Default Calibration Settings about Tx, Rx, ADC and write BIN file

11.4 AGC

This procedure is for Rx calibration.

In this procedure, We can get RSSI correction value. Set band EGSM and press Start button the result window will show correction values per every power level and gain code and the same measure is performed per every frequency.

11.5 APC

This procedure is for Txcalibration.

In this procedure you can get proper scale factor value and measured power level.

11.6 ADC

This procedure is for battery calibration.

You can get main Battery Config Table and temperature Config Table

11.7 Setting

check com port and cable loss. Select automatic calibration item.

If you uncheck one item calibration will stop from the unchecked item.

This is useful when you want to process only oneitem.

11.8 How to do calibration

- A. Connect cable between phone and serial port of PC.
- B. Connect Ag8960 equipment and Power Supply and phone.
- C. Set correct port and baud rate.
- D. Press Start button. AutoCal process all calibration procedure
 - i. AGC EGSM
 - ii. AGC DCS
 - iii. APC EGSM
 - iv. APC DCS
 - v. ADC
- E. After finished all measurement. The state is return to SETUP.
- F. The Cal file will be generated and then the calibration data will be written into phone and then will be reset.

12.1 Exploded View

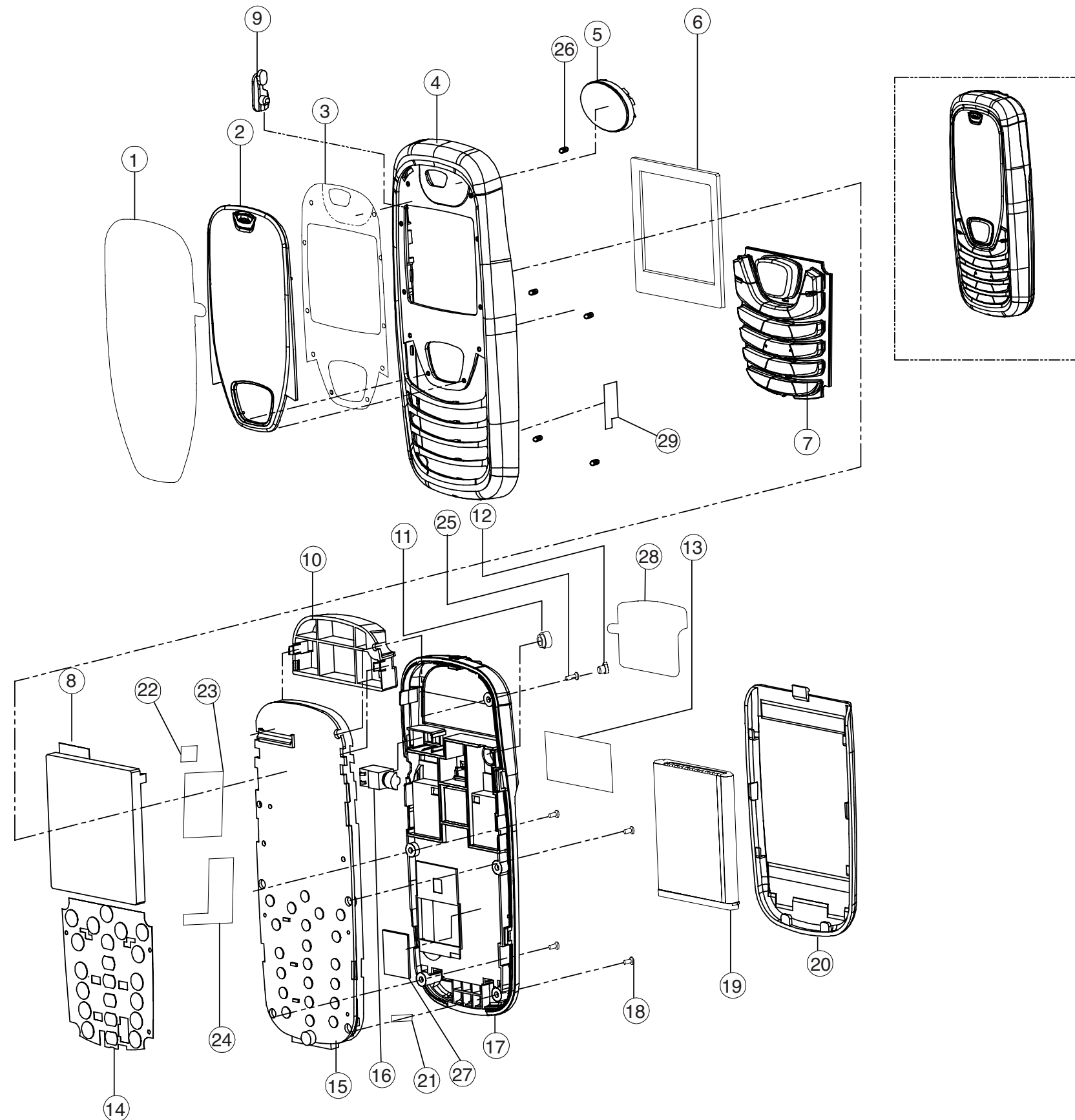

30	LABEL,APPROVAL	1	MLAA0030701	
29	TAPE[JTACK]	1	MTAZ0063601	
28	TAPE[PROTECTION REAR]	1	MTAZ0063001	
27	TAPE[REAR]	1	MTAZ0063501	
26	INSERT	1	MICZ0016801	
25	SCREW M1.4_H4.0	1	GMZY0004001	
24	TAPE SHIELD (L)	1	MTAC0021401	
23	TAPE SHIELD (A)	1	MTAC0021301	
22	TAPE FPCB	1	MTAZ0060101	
21	GASKET SHIELD FORM	1	MGAD0079301	
20	COVER-BATTERY	1	MCJA0013801	
19	BATTERY-MODULE	1	SBCL0001303	
18	SCREW M1.4_H3.0	4	GMZZ0015101	
17	COVER-REAR	1	MCJN0030101	
16	VIBRATOR	1	SJMY0007001	
15	PCB-ASS'Y	1	SAFY0119701	
14	DOME ASSY METAL	1	ADCA0030501	
13	LABEL	1	MLAK0013601	
12	CAP-SCREW	1	MCCH0039801	
11	CAP-MOBILE SWITCH	1	MCCF0020901	
10	INTTENNA	1	SNGF0006401	
9	CAP-EARJACK	1	MCCC0020201	
8	LCD-MODULE	1	SVLY0025501	
7	KEY-PAD ASS'Y	1	AKAZ0007501	
6	PAD-LCD	1	MPBG0028301	
5	SPEAKER	1	SUSY0014801	
4	COVER-FRONT	1	MCJK0033701	
3	TAPE-WINDOW-LCD	1	MTAD0030601	
2	WINDOW ASSY LCD	1	AWAB0016501	
1	TAPE-PROTECTION	1	MTAB0062301	
NO.	DESCRIPTION	Q'TY	DRAWING NO.	REMARK

12.2 Replacement Parts

<Mechanic component>

Note: This Chapter is used for reference, Part order is ordered by SBOM standard on GCSC

Level	Location No.	Description	Part Number	Specification	Color	Remark
1		GSM,BAR/FILP	TGSM0039409		Black	
2	AAAY00	ADDITION	AAAY0128019		Black	
3	MCJA00	COVER,BATTERY	MCJA0013801		Black	20
2	APEY00	PHONE	APEY0177393		Black	
3	ACGK00	COVER ASSY,FRONT	ACGK0044606		Black	
4	AWAB00	WINDOW ASSY,LCD	AWAB0016502	FM RADIO	Silver	2
5	BFAA00	FILM,INMOLD	BFAA0024302	FM RADIO		
5	MWAC	WINDOW,LCD	MWAC0046802	FM RADIO	Without Color	
4	MCCC	CAP,EARPHONE JACK	MCCC0020201		Black	9
4	MCJK	COVER,FRONT	MCJK0033704		Black	4
4	MICZ	INSERT	MICZ0016801		Without Color	26
4	MPBG	PAD,LCD	MPBG0028301		Without Color	6
4	MTAB	TAPE,PROTECTION	MTAB0062301		Without Color	1
4	MTAD	TAPE,WINDOW	MTAD0030601		Without Color	3
4	MTAZ	TAPE	MTAZ0063601		Without Color	29
3	ACGM00	COVER ASSY,REAR	ACGM0044201		Black	
4	MCJN00	COVER,REAR	MCJN0030101		Black	17
4	MTAB	TAPE,PROTECTION	MTAB0069501		Without Color	
4	MTAZ00	TAPE	MTAZ0063501		Without Color	27
3	AKAZ00	KEYPAD ASSY	AKAZ0007509		Black	7
3	GMEY00	SCREW MACHINE,BIND	GMEY0004001	1.4 mm,4.0 mm,MSWR3(BK) ,B ,+ ,HEAE t=0.6, HEAD d2.5	Black	25
3	GMZZ00	SCREW MACHINE	GMZZ0015101	1.4 mm,3.0 mm,MSWR3(FN) ,N ,+ , - ,	Silver	18
3	MCCF00	CAP,MOBILE SWITCH	MCCF0020901		Black	11
3	MCCH00	CAP,SCREW	MCCH0039801		Black	12
3	MLAK00	LABEL,MODEL	MLAK0013601		Without Color	13
5	ADCA00	DOME ASSY,METAL	ADCA0030501		Without Color	14

12. EXPLODED VIEW & REPLACEMENT PART LIST

Level	Location No.	Description	Part Number	Specification	Color	Remark
5	MGAD00	GASKET,SHIELD FORM	MGAD0079301		Gold	21
5	MTAC00	TAPE,SHIELD	MTAC0021401		Gold	24
5	MTAC01	TAPE,SHIELD	MTAC0021302	3X6X0.28t-material-EMI TAPE	Gold	23
5	MTAC02	TAPE,SHIELD	MTAC0021402	30X25X0.28t-material-EMI TAPE	Gold	
5	MTAZ00	TAPE	MTAZ0060101		Without Color	22
5	MLAB00	LABEL,A/S	MLAB0000601	HUMIDITY STICKER	Without Color	
5	MLAC00	LABEL,BARCODE	MLAC0003301	EZ LOOKS(use for PCB ASSY MAIN(hardware))	Without Color	

12. EXPLODED VIEW & REPLACEMENT PART LIST

12.2 Replacement Parts

<Main component>

Note: This Chapter is used for reference, Part order is ordered by SBOM standard on GCSC

Level	Location No.	Description	Part Number	Specification	Color	Remark
4	SUSY	SPEAKER	SUSY0014801	PIN ,8 ohm,88 dB,20 mm,*14mm		5
4	SJMY00	VIBRATOR,MOTOR	SJMY0007001	3 V,0.085 A,4*12.5 ,6.6T,L3100,SILINDER		16
3	SAFY00	PCB ASSY,MAIN	SAFY0119732			15
4	SAFB00	PCB ASSY,MAIN,INSERT	SAFB0040302			
5	SBCL00	BATTERY,CELL,LITHIUM	SBCL0001303	2 V,1 mAh,COIN ,SOLDER TYPE BACKUP BATTERY		19
5	SNGF00	ANTENNA,GSM,FIXED	SNGF0006401	3.0 ,-2 dBd ,EGSM+DCS+PCS, Radio Intenna		10
5	SUMY00	MICROPHONE	SUMY0003802	FPCB ,-42 dB,4*1.5 ,		
5	SVLY00	LCD	SVLY0025501	MAIN ,128*128 ,35.78*39.7 ,65k ,CSTN ,TM ,ST7636 (Sitronix) ,		8
4	SAFF00	PCB ASSY,MAIN,SMT	SAFF0058617			
5	SAFC00	PCB ASSY,MAIN,SMT BOTTOM	SAFC0047303			
6	C100	CAP,CERAMIC,CHIP	ECCH0000163	47 nF,10V,K,X5R,HD,1005,R/TP		
6	C101	CAP,CERAMIC,CHIP	ECCH0004904	1 uF,6.3V ,K ,X5R ,TC ,1005 ,R/TP		
6	C102	CAP,CERAMIC,CHIP	ECCH0004904	1 uF,6.3V ,K ,X5R ,TC ,1005 ,R/TP		
6	C103	CAP,CERAMIC,CHIP	ECCH0004904	1 uF,6.3V ,K ,X5R ,TC ,1005 ,R/TP		
6	C104	CAP,CERAMIC,CHIP	ECCH0000163	47 nF,10V,K,X5R,HD,1005,R/TP		
6	C105	CAP,CERAMIC,CHIP	ECCH0004904	1 uF,6.3V ,K ,X5R ,TC ,1005 ,R/TP		
6	C106	CAP,CERAMIC,CHIP	ECCH0004904	1 uF,6.3V ,K ,X5R ,TC ,1005 ,R/TP		
6	C107	CAP,CERAMIC,CHIP	ECCH0000163	47 nF,10V,K,X5R,HD,1005,R/TP		
6	C108	CAP,CERAMIC,CHIP	ECCH0000163	47 nF,10V,K,X5R,HD,1005,R/TP		
6	C109	CAP,CERAMIC,CHIP	ECCH0000393	22 uF,6.3V ,M ,X5R ,HD ,2012 ,R/TP		
6	C110	CAP,CERAMIC,CHIP	ECCH0000115	22 pF,50V,J,NP0,TC,1005,R/TP		
6	C111	CAP,CERAMIC,CHIP	ECCH0000163	47 nF,10V,K,X5R,HD,1005,R/TP		
6	C112	CAP,CERAMIC,CHIP	ECCH0004904	1 uF,6.3V ,K ,X5R ,TC ,1005 ,R/TP		
6	C113	CAP,CERAMIC,CHIP	ECCH0004904	1 uF,6.3V ,K ,X5R ,TC ,1005 ,R/TP		
6	C114	CAP,CERAMIC,CHIP	ECCH0004904	1 uF,6.3V ,K ,X5R ,TC ,1005 ,R/TP		
6	C115	CAP,CERAMIC,CHIP	ECCH0004904	1 uF,6.3V ,K ,X5R ,TC ,1005 ,R/TP		
6	C116	CAP,CERAMIC,CHIP	ECCH0004904	1 uF,6.3V ,K ,X5R ,TC ,1005 ,R/TP		
6	C117	CAP,CERAMIC,CHIP	ECCH0005801	2.2 uF,6.3V ,K ,X5R ,TC ,1608 ,R/TP		
6	C118	CAP,CERAMIC,CHIP	ECCH0004904	1 uF,6.3V ,K ,X5R ,TC ,1005 ,R/TP		
6	C119	CAP,CERAMIC,CHIP	ECCH0004904	1 uF,6.3V ,K ,X5R ,TC ,1005 ,R/TP		

12. EXPLODED VIEW & REPLACEMENT PART LIST

Level	Location No.	Description	Part Number	Specification	Color	Remark
6	C120	CAP,CERAMIC,CHIP	ECCH0000122	47 pF,50V,J,NP0,TC,1005,R/TP		
6	C121	CAP,CERAMIC,CHIP	ECCH0000165	68 nF,6.3V,K,X5R,HD,1005,R/TP		
6	C122	CAP,CERAMIC,CHIP	ECCH0004904	1 uF,6.3V ,K ,X5R ,TC ,1005 ,R/TP		
6	C123	CAP,CERAMIC,CHIP	ECCH0000143	1 nF,50V,K,X7R,HD,1005,R/TP		
6	C124	CAP,CERAMIC,CHIP	ECCH0000143	1 nF,50V,K,X7R,HD,1005,R/TP		
6	C127	CAP,TANTAL,CHIP	ECTH0001701	10 uF,6.3V ,M ,L_ESR ,2012 ,R/TP		
6	C129	CAP,CERAMIC,CHIP	ECCH0000143	1 nF,50V,K,X7R,HD,1005,R/TP		
6	C132	CAP,CERAMIC,CHIP	ECCH0004904	1 uF,6.3V ,K ,X5R ,TC ,1005 ,R/TP		
6	C133	CAP,CERAMIC,CHIP	ECCH0000120	39 pF,50V,J,NP0,TC,1005,R/TP		
6	C134	CAP,CERAMIC,CHIP	ECCH0000120	39 pF,50V,J,NP0,TC,1005,R/TP		
6	C135	CAP,CERAMIC,CHIP	ECCH0000120	39 pF,50V,J,NP0,TC,1005,R/TP		
6	C136	CAP,CERAMIC,CHIP	ECCH0000120	39 pF,50V,J,NP0,TC,1005,R/TP		
6	C137	CAP,CERAMIC,CHIP	ECCH0004904	1 uF,6.3V ,K ,X5R ,TC ,1005 ,R/TP		
6	C138	CAP,CERAMIC,CHIP	ECCH0004904	1 uF,6.3V ,K ,X5R ,TC ,1005 ,R/TP		
6	C139	CAP,CERAMIC,CHIP	ECCH0000120	39 pF,50V,J,NP0,TC,1005,R/TP		
6	C140	CAP,CERAMIC,CHIP	ECCH0000120	39 pF,50V,J,NP0,TC,1005,R/TP		
6	C141	CAP,CERAMIC,CHIP	ECCH0000120	39 pF,50V,J,NP0,TC,1005,R/TP		
6	C142	CAP,CERAMIC,CHIP	ECCH0004904	1 uF,6.3V ,K ,X5R ,TC ,1005 ,R/TP		
6	C143	CAP,CERAMIC,CHIP	ECCH0000120	39 pF,50V,J,NP0,TC,1005,R/TP		
6	C144	CAP,CERAMIC,CHIP	ECCH0000120	39 pF,50V,J,NP0,TC,1005,R/TP		
6	C149	CAP,CERAMIC,CHIP	ECCH0000117	27 pF,50V,J,NP0,TC,1005,R/TP		
6	C200	CAP,CERAMIC,CHIP	ECCH0000120	39 pF,50V,J,NP0,TC,1005,R/TP		
6	C203	CAP,CERAMIC,CHIP	ECCH0000182	0.1 uF,10V ,K ,X5R ,HD ,1005 ,R/TP		
6	C205	CAP,CERAMIC,CHIP	ECCH0000120	39 pF,50V,J,NP0,TC,1005,R/TP		
6	C206	CAP,TANTAL,CHIP,MAKER	ECTZ0003101	33 uF,10V ,M ,STD ,ETC ,R/TP		
6	C207	CAP,TANTAL,CHIP,MAKER	ECTZ0005201	10 uF,6.3V ,M ,L_ESR ,1608 ,R/TP		
6	C208	CAP,TANTAL,CHIP,MAKER	ECTZ0005201	10 uF,6.3V ,M ,L_ESR ,1608 ,R/TP		
6	C212	CAP,CERAMIC,CHIP	ECCH0007901	10 uF,4V ,M ,X5R ,TC ,1608 ,R/TP		
6	C215	CAP,CERAMIC,CHIP	ECCH0007901	10 uF,4V ,M ,X5R ,TC ,1608 ,R/TP		
6	C217	CAP,CERAMIC,CHIP	ECCH0000120	39 pF,50V,J,NP0,TC,1005,R/TP		
6	C219	CAP,CERAMIC,CHIP	ECCH0000110	10 pF,50V,D,NP0,TC,1005,R/TP		
6	C220	CAP,TANTAL,CHIP,MAKER	ECTZ0005201	10 uF,6.3V ,M ,L_ESR ,1608 ,R/TP		
6	C221	CAP,CERAMIC,CHIP	ECCH0000182	0.1 uF,10V ,K ,X5R ,HD ,1005 ,R/TP		
6	C222	CAP,CERAMIC,CHIP	ECCH0000182	0.1 uF,10V ,K ,X5R ,HD ,1005 ,R/TP		

12. EXPLODED VIEW & REPLACEMENT PART LIST

Level	Location No.	Description	Part Number	Specification	Color	Remark
6	C223	CAP,CERAMIC,CHIP	ECCH0000182	0.1 uF,10V ,K ,X5R ,HD ,1005 ,R/TP		
6	C224	CAP,CERAMIC,CHIP	ECCH0000159	22 nF,16V,K,X7R,HD,1005,R/TP		
6	C225	CAP,CERAMIC,CHIP	ECCH0000159	22 nF,16V,K,X7R,HD,1005,R/TP		
6	C226	CAP,CERAMIC,CHIP	ECCH0000159	22 nF,16V,K,X7R,HD,1005,R/TP		
6	C227	CAP,TANTAL,CHIP,MAKER	ECTZ0005201	10 uF,6.3V ,M ,L_ ESR ,1608 ,R/TP		
6	C228	CAP,CERAMIC,CHIP	ECCH0004904	1 uF,6.3V ,K ,X5R ,TC ,1005 ,R/TP		
6	C229	CAP,CERAMIC,CHIP	ECCH0000157	15 nF,16V,K,X7R,HD,1005,R/TP		
6	C231	CAP,CERAMIC,CHIP	ECCH0000157	15 nF,16V,K,X7R,HD,1005,R/TP		
6	C232	CAP,TANTAL,CHIP,MAKER	ECTZ0005201	10 uF,6.3V ,M ,L_ ESR ,1608 ,R/TP		
6	C233	CAP,CERAMIC,CHIP	ECCH0000122	47 pF,50V,J,NP0,TC,1005,R/TP		
6	C234	CAP,CERAMIC,CHIP	ECCH0000122	47 pF,50V,J,NP0,TC,1005,R/TP		
6	C235	CAP,TANTAL,CHIP,MAKER	ECTZ0005201	10 uF,6.3V ,M ,L_ ESR ,1608 ,R/TP		
6	C236	CAP,CERAMIC,CHIP	ECCH0004904	1 uF,6.3V ,K ,X5R ,TC ,1005 ,R/TP		
6	C300	CAP,CERAMIC,CHIP	ECCH0006201	4.7 uF,6.3V ,K ,X5R ,TC ,1608 ,R/TP		
6	C301	CAP,CERAMIC,CHIP	ECCH0004904	1 uF,6.3V ,K ,X5R ,TC ,1005 ,R/TP		
6	C302	CAP,CERAMIC,CHIP	ECCH0000155	10 nF,16V,K,X7R,HD,1005,R/TP		
6	C303	CAP,CERAMIC,CHIP	ECCH0004904	1 uF,6.3V ,K ,X5R ,TC ,1005 ,R/TP		
6	C304	CAP,CERAMIC,CHIP	ECCH0000117	27 pF,50V,J,NP0,TC,1005,R/TP		
6	C305	CAP,CERAMIC,CHIP	ECCH0000120	39 pF,50V,J,NP0,TC,1005,R/TP		
6	C306	CAP,CERAMIC,CHIP	ECCH0000110	10 pF,50V,D,NP0,TC,1005,R/TP		
6	C307	CAP,CERAMIC,CHIP	ECCH0000104	3 pF,50V,C,NP0,TC,1005,R/TP		
6	C308	CAP,CERAMIC,CHIP	ECCH0004904	1 uF,6.3V ,K ,X5R ,TC ,1005 ,R/TP		
6	C309	CAP,CERAMIC,CHIP	ECCH0000117	27 pF,50V,J,NP0,TC,1005,R/TP		
6	C310	CAP,CERAMIC,CHIP	ECCH0004904	1 uF,6.3V ,K ,X5R ,TC ,1005 ,R/TP		
6	C311	CAP,CERAMIC,CHIP	ECCH0000117	27 pF,50V,J,NP0,TC,1005,R/TP		
6	C312	CAP,CERAMIC,CHIP	ECCH0004904	1 uF,6.3V ,K ,X5R ,TC ,1005 ,R/TP		
6	C313	CAP,CERAMIC,CHIP	ECCH0006501	10 uF,6.3V ,K ,X5R ,TC ,2012 ,R/TP		
6	C315	CAP,CERAMIC,CHIP	ECCH0004902	220 nF,10V ,Z ,Y5V ,TC ,1005 ,R/TP		
6	C316	CAP,CERAMIC,CHIP	ECCH0000143	1 nF,50V,K,X7R,HD,1005,R/TP		
6	C325	CAP,CERAMIC,CHIP	ECCH0000182	0.1 uF,10V ,K ,X5R ,HD ,1005 ,R/TP		
6	C326	CAP,CERAMIC,CHIP	ECCH0004904	1 uF,6.3V ,K ,X5R ,TC ,1005 ,R/TP		
6	C327	CAP,CERAMIC,CHIP	ECCH0004904	1 uF,6.3V ,K ,X5R ,TC ,1005 ,R/TP		
6	C328	CAP,CERAMIC,CHIP	ECCH0004904	1 uF,6.3V ,K ,X5R ,TC ,1005 ,R/TP		
6	C329	CAP,CERAMIC,CHIP	ECCH0004904	1 uF,6.3V ,K ,X5R ,TC ,1005 ,R/TP		

12. EXPLODED VIEW & REPLACEMENT PART LIST

Level	Location No.	Description	Part Number	Specification	Color	Remark
6	C330	CAP,CERAMIC,CHIP	ECCH0004904	1 uF,6.3V ,K ,X5R ,TC ,1005 ,R/TP		
6	C350	CAP,CERAMIC,CHIP	ECCH0000143	1 nF,50V,K,X7R,HD,1005,R/TP		
6	C401	CAP,CERAMIC,CHIP	ECCH0000276	1 uF,10V,Z,Y5V,HD,1608,R/TP		
6	C402	CAP,CERAMIC,CHIP	ECCH0000122	47 pF,50V,J,NP0,TC,1005,R/TP		
6	C403	CAP,CERAMIC,CHIP	ECCH0000393	22 uF,6.3V ,M ,X5R ,HD ,2012 ,R/TP		
6	C404	CAP,CERAMIC,CHIP	ECCH0001811	220000 pF,10V ,Z ,Y5V ,HD ,1005 ,R/TP		
6	C405	CAP,CERAMIC,CHIP	ECCH0001811	220000 pF,10V ,Z ,Y5V ,HD ,1005 ,R/TP		
6	C501	CAP,CERAMIC,CHIP	ECCH0000120	39 pF,50V,J,NP0,TC,1005,R/TP		
6	C502	RES,CHIP	ERHY0000201	0 ohm,1/16W,J,1005,R/TP		
6	C503	CAP,CERAMIC,CHIP	ECCH0000102	1 pF,50V ,C ,NP0 ,TC ,1005 ,R/TP		
6	C504	CAP,CERAMIC,CHIP	ECCH0000117	27 pF,50V,J,NP0,TC,1005,R/TP		
6	C505	CAP,CERAMIC,CHIP	ECCH0000113	18 pF,50V,J,NP0,TC,1005,R/TP		
6	C507	CAP,CERAMIC,CHIP	ECCH0000155	10 nF,16V,K,X7R,HD,1005,R/TP		
6	C508	CAP,CERAMIC,CHIP	ECCH0000104	3 pF,50V,C,NP0,TC,1005,R/TP		
6	C509	CAP,CERAMIC,CHIP	ECCH0000110	10 pF,50V,D,NP0,TC,1005,R/TP		
6	C510	CAP,TANTAL,CHIP,MAKER	ECTZ0003101	33 uF,10V ,M ,STD ,ETC ,R/TP		
6	C511	CAP,CERAMIC,CHIP	ECCH0000117	27 pF,50V,J,NP0,TC,1005,R/TP		
6	C512	CAP,CERAMIC,CHIP	ECCH0000901	2.2 pF,50V ,C ,NP0 ,TC ,1005 ,R/TP		
6	C513	CAP,CERAMIC,CHIP	ECCH0000178	1.8 pF,50V ,D ,NP0 ,TC ,1005 ,R/TP		
6	C514	CAP,CERAMIC,CHIP	ECCH0000120	39 pF,50V,J,NP0,TC,1005,R/TP		
6	C515	INDUCTOR,CHIP	ELCH0001003	6.8 nH,J ,1005 ,R/TP ,chip inductor PBFREE		
6	C516	CAP,CERAMIC,CHIP	ECCH0000120	39 pF,50V,J,NP0,TC,1005,R/TP		
6	C517	INDUCTOR,CHIP	ELCH0001001	10 nH,J ,1005 ,R/TP ,Pb Free		
6	C518	CAP,CERAMIC,CHIP	ECCH0000159	22 nF,16V,K,X7R,HD,1005,R/TP		
6	C519	CAP,CERAMIC,CHIP	ECCH0000115	22 pF,50V,J,NP0,TC,1005,R/TP		
6	C523	CAP,CERAMIC,CHIP	ECCH0000128	100 pF,50V,J,NP0,TC,1005,R/TP		
6	C524	CAP,CERAMIC,CHIP	ECCH0000103	1.5 pF,50V,C,NP0,TC,1005,R/TP		
6	C525	CAP,CERAMIC,CHIP	ECCH0000103	1.5 pF,50V,C,NP0,TC,1005,R/TP		
6	C527	CAP,CERAMIC,CHIP	ECCH0000159	22 nF,16V,K,X7R,HD,1005,R/TP		
6	C528	CAP,CERAMIC,CHIP	ECCH0000115	22 pF,50V,J,NP0,TC,1005,R/TP		
6	C530	CAP,CERAMIC,CHIP	ECCH0000143	1 nF,50V,K,X7R,HD,1005,R/TP		
6	C531	CAP,CERAMIC,CHIP	ECCH0000103	1.5 pF,50V,C,NP0,TC,1005,R/TP		
6	C532	CAP,CERAMIC,CHIP	ECCH0000143	1 nF,50V,K,X7R,HD,1005,R/TP		
6	C533	CAP,CERAMIC,CHIP	ECCH0007901	10 uF,4V ,M ,X5R ,TC ,1608 ,R/TP		

12. EXPLODED VIEW & REPLACEMENT PART LIST

Level	Location No.	Description	Part Number	Specification	Color	Remark
6	C534	CAP,CERAMIC,CHIP	ECCH0007901	10 uF,4V ,M ,X5R ,TC ,1608 ,R/TP		
6	C535	CAP,CERAMIC,CHIP	ECCH0000135	270 pF,50V ,K ,X7R ,HD ,1005 ,R/TP		
6	C536	CAP,CERAMIC,CHIP	ECCH0005801	2.2 uF,6.3V ,K ,X5R ,TC ,1608 ,R/TP		
6	C537	CAP,CERAMIC,CHIP	ECCH0000135	270 pF,50V ,K ,X7R ,HD ,1005 ,R/TP		
6	C538	CAP,CERAMIC,CHIP	ECCH0000143	1 nF,50V,K,X7R,HD,1005,R/TP		
6	C539	CAP,CERAMIC,CHIP	ECCH0000135	270 pF,50V ,K ,X7R ,HD ,1005 ,R/TP		
6	C540	CAP,CERAMIC,CHIP	ECCH0000103	1.5 pF,50V,C,NP0,TC,1005,R/TP		
6	C541	CAP,CERAMIC,CHIP	ECCH0000178	1.8 pF,50V ,D ,NP0 ,TC ,1005 ,R/TP		
6	C542	CAP,CERAMIC,CHIP	ECCH0000178	1.8 pF,50V ,D ,NP0 ,TC ,1005 ,R/TP		
6	C543	CAP,CERAMIC,CHIP	ECCH0000115	22 pF,50V,J,NP0,TC,1005,R/TP		
6	C700	CAP,CERAMIC,CHIP	ECCH0000128	100 pF,50V,J,NP0,TC,1005,R/TP		
6	C701	CAP,CERAMIC,CHIP	ECCH0000106	5 pF,50V,C,NP0,TC,1005,R/TP		
6	C702	CAP,CERAMIC,CHIP	ECCH0000110	10 pF,50V,D,NP0,TC,1005,R/TP		
6	C703	CAP,CERAMIC,CHIP	ECCH0000182	0.1 uF,10V ,K ,X5R ,HD ,1005 ,R/TP		
6	C704	CAP,CERAMIC,CHIP	ECCH0000182	0.1 uF,10V ,K ,X5R ,HD ,1005 ,R/TP		
6	C705	CAP,CERAMIC,CHIP	ECCH0000182	0.1 uF,10V ,K ,X5R ,HD ,1005 ,R/TP		
6	C706	CAP,CERAMIC,CHIP	ECCH0000182	0.1 uF,10V ,K ,X5R ,HD ,1005 ,R/TP		
6	C707	CAP,CERAMIC,CHIP	ECCH0004904	1 uF,6.3V ,K ,X5R ,TC ,1005 ,R/TP		
6	C708	CAP,CERAMIC,CHIP	ECCH0000128	100 pF,50V,J,NP0,TC,1005,R/TP		
6	C709	CAP,CERAMIC,CHIP	ECCH0004904	1 uF,6.3V ,K ,X5R ,TC ,1005 ,R/TP		
6	C710	CAP,TANTAL,CHIP,MAKER	ECTZ0005201	10 uF,6.3V ,M ,L ,ESR ,1608 ,R/TP		
6	C711	CAP,CERAMIC,CHIP	ECCH0004904	1 uF,6.3V ,K ,X5R ,TC ,1005 ,R/TP		
6	C712	CAP,CERAMIC,CHIP	ECCH0000182	0.1 uF,10V ,K ,X5R ,HD ,1005 ,R/TP		
6	C713	CAP,CERAMIC,CHIP	ECCH0007901	10 uF,4V ,M ,X5R ,TC ,1608 ,R/TP		
6	C714	CAP,CERAMIC,CHIP	ECCH0000143	1 nF,50V,K,X7R,HD,1005,R/TP		
6	C715	CAP,CERAMIC,CHIP	ECCH0000102	1 pF,50V ,C ,NP0 ,TC ,1005 ,R/TP		
6	C716	CAP,CERAMIC,CHIP	ECCH0000143	1 nF,50V,K,X7R,HD,1005,R/TP		
6	C717	CAP,CERAMIC,CHIP	ECCH0007901	10 uF,4V ,M ,X5R ,TC ,1608 ,R/TP		
6	C718	CAP,CERAMIC,CHIP	ECCH0004904	1 uF,6.3V ,K ,X5R ,TC ,1005 ,R/TP		
6	C719	CAP,CERAMIC,CHIP	ECCH0004904	1 uF,6.3V ,K ,X5R ,TC ,1005 ,R/TP		
6	C720	CAP,CERAMIC,CHIP	ECCH0000161	33 nF,16V,K,X7R,HD,1005,R/TP		
6	C721	CAP,CERAMIC,CHIP	ECCH0004904	1 uF,6.3V ,K ,X5R ,TC ,1005 ,R/TP		
6	C722	CAP,CERAMIC,CHIP	ECCH0004904	1 uF,6.3V ,K ,X5R ,TC ,1005 ,R/TP		
6	C723	CAP,CERAMIC,CHIP	ECCH0004904	1 uF,6.3V ,K ,X5R ,TC ,1005 ,R/TP		

12. EXPLODED VIEW & REPLACEMENT PART LIST

Level	Location No.	Description	Part Number	Specification	Color	Remark
6	C724	CAP,CERAMIC,CHIP	ECCH0000279	0.47 uF,10V ,Z ,Y5V ,HD ,1608 ,R/TP		
6	C725	CAP,CERAMIC,CHIP	ECCH0000163	47 nF,10V,K,X5R,HD,1005,R/TP		
6	C726	CAP,CERAMIC,CHIP	ECCH0000113	18 pF,50V,J,NP0,TC,1005,R/TP		
6	C727	CAP,CERAMIC,CHIP	ECCH0000113	18 pF,50V,J,NP0,TC,1005,R/TP		
6	C728	CAP,CERAMIC,CHIP	ECCH0004904	1 uF,6.3V ,K ,X5R ,TC ,1005 ,R/TP		
6	C730	CAP,CERAMIC,CHIP	ECCH0000117	27 pF,50V,J,NP0,TC,1005,R/TP		
6	C731	CAP,CERAMIC,CHIP	ECCH0000117	27 pF,50V,J,NP0,TC,1005,R/TP		
6	C732	CAP,CERAMIC,CHIP	ECCH0000117	27 pF,50V,J,NP0,TC,1005,R/TP		
6	C733	CAP,CERAMIC,CHIP	ECCH0000117	27 pF,50V,J,NP0,TC,1005,R/TP		
6	C734	CAP,CERAMIC,CHIP	ECCH0000155	10 nF,16V,K,X7R,HD,1005,R/TP		
6	CN300	CONNECTOR,I/O	ENRY0003501	24 PIN,0.5 mm,ANGLE , ,		
6	D100	DIODE,SWITCHING	EDSY0012101	US-FLAT ,30 V,1 A,R/TP ,2.5*1.25*0.6(t)		
6	D101	DIODE,SWITCHING	EDSY0005701	EMT3 ,80 V,4 A,R/TP ,		
6	D300	DIODE,SWITCHING	EDSY0012301	1-1E1A ,85 V,1 A,R/TP ,P=200mW, IFM=200mA		
6	D700	DIODE,VARIABLE CAP	EDVY0001202	UFP ,25 pF,R/TP ,diode capacitance:C1:25~28.5pF/C4:4.8~6.8pF		
6	D701	DIODE,VARIABLE CAP	EDVY0001202	UFP ,25 pF,R/TP ,diode capacitance:C1:25~28.5pF/C4:4.8~6.8pF		
6	FL400	FILTER,EMI/POWER	SFEY0006401	SMD ,6 Channel, EMI+ESD, CSP,Pb-free		
6	FL401	FILTER,EMI/POWER	SFEY0006401	SMD ,6 Channel, EMI+ESD, CSP,Pb-free		
6	FL402	FILTER,EMI/POWER	SFEY0006401	SMD ,6 Channel, EMI+ESD, CSP,Pb-free		
6	FL403	FILTER,EMI/POWER	SFEY0006401	SMD ,6 Channel, EMI+ESD, CSP,Pb-free		
6	FL500	FILTER,SEPERATOR	SFAY0003802	900.1800 ,1900 ,3.0 dB,3.8 dB,25 dB,23 dB,ETC ,7.2*5.0*1.8mm		
6	J200	CONN,JACK/PLUG, EARPHONE	ENJE0003102	4 ,4 PIN,BOSS-2		
6	J300	CONN,SOCKET	ENSY0007608	6 PIN,ETC ,BRIDGE NON PROTECTOR TYPE ,2.54 mm,2.7T		
6	L200	INDUCTOR,CHIP	ELCH0010401	2.2 uH,M ,1005 ,R/TP ,		
6	L201	INDUCTOR,CHIP	ELCH0010401	2.2 uH,M ,1005 ,R/TP ,		
6	L202	INDUCTOR,CHIP	ELCH0004103	4.7 uH,K ,1608 ,R/TP ,CHIP		
6	L500	INDUCTOR,CHIP	ELCH0005002	2.7 nH,S ,1005 ,R/TP ,		
6	L501	CAP,CERAMIC,CHIP	ECCH0000104	3 pF,50V,C,NP0,TC,1005,R/TP		
6	L502	INDUCTOR,CHIP	ELCH0002716	5.1 nH,J ,1608 ,R/TP ,coil inductor		
6	L504	INDUCTOR,CHIP	ELCH0002719	6.2 nH,J ,1608 ,R/TP ,COIL INDUCTOR		
6	L506	INDUCTOR,CHIP	ELCH0001413	22 nH,J ,1005 ,R/TP ,PBFREE		
6	L550	INDUCTOR,CHIP	ELCH0005010	1.8 nH,S ,1005 ,R/TP ,		

12. EXPLODED VIEW & REPLACEMENT PART LIST

Level	Location No.	Description	Part Number	Specification	Color	Remark
6	L700	RES,CHIP	ERHY0000201	0 ohm,1/16W,J,1005,R/TP		
6	L701	INDUCTOR,CHIP	ELCH0010402	270 nH,M ,1005 ,R/TP ,CHIP		
6	L702	INDUCTOR,CHIP	ELCH0009105	18 nH,J ,1005 ,R/TP ,COIL		
6	L703	INDUCTOR,CHIP	ELCH0009105	18 nH,J ,1005 ,R/TP ,COIL		
6	Q100	TR,FET,P-CHANNEL	EQFP0004201	2.9*1.9*0.8(t) ,.7 W,20 V,-6 A,R/TP ,NDC652P upgrade(substitution) item, Pb free		
6	Q200	TR,BJT,NPN	EQBN0004801	SMT6 ,0.2 W,R/TP ,		
6	Q301	TR,BJT,NPN	EQBN0004801	SMT6 ,0.2 W,R/TP ,		
6	Q400	TR,BJT,NPN	EQBN0007101	EMT3 ,0.15 W,R/TP ,LOW FREQUENCY		
6	Q401	TR,BJT,NPN	EQBN0007101	EMT3 ,0.15 W,R/TP ,LOW FREQUENCY		
6	R104	RES,CHIP	ERHY0000261	10K ohm,1/16W,J,1005,R/TP		
6	R105	RES,CHIP	ERHY0000220	100 ohm,1/16W,J,1005,R/TP		
6	R108	RES,CHIP	ERHY0001102	0.2 ohm,1/4W ,F ,2012 ,R/TP		
6	R109	RES,CHIP	ERHY0000230	330 ohm,1/16W,J,1005,R/TP		
6	R110	RES,CHIP	ERHY0000512	10M ohm,1/16W,J,1608,R/TP		
6	R111	RES,CHIP	ERHY0000202	4.7 ohm,1/16W,J,1005,R/TP		
6	R112	RES,CHIP	ERHY0000278	82K ohm,1/16W,J,1005,R/TP		
6	R113	RES,CHIP	ERHY0000280	100K ohm,1/16W,J,1005,R/TP		
6	R114	RES,CHIP	ERHY0000202	4.7 ohm,1/16W,J,1005,R/TP		
6	R117	RES,CHIP	ERHY0000254	4.7K ohm,1/16W,J,1005,R/TP		
6	R118	RES,CHIP	ERHY0000261	10K ohm,1/16W,J,1005,R/TP		
6	R130	RES,CHIP	ERHY0000280	100K ohm,1/16W,J,1005,R/TP		
6	R131	RES,CHIP	ERHY0000280	100K ohm,1/16W,J,1005,R/TP		
6	R140	RES,CHIP	ERHY0000220	100 ohm,1/16W,J,1005,R/TP		
6	R201	RES,CHIP	ERHY0000247	2.2K ohm,1/16W,J,1005,R/TP		
6	R202	RES,CHIP	ERHY0000296	1M ohm,1/16W,J,1005,R/TP		
6	R204	RES,CHIP	ERHY0000250	3.3K ohm,1/16W,J,1005,R/TP		
6	R205	RES,CHIP	ERHY0000265	20K ohm,1/16W,J,1005,R/TP		
6	R206	RES,CHIP	ERHY0000265	20K ohm,1/16W,J,1005,R/TP		
6	R209	RES,CHIP	ERHY0000287	220K ohm,1/16W,J,1005,R/TP		
6	R211	RES,CHIP	ERHY0000202	4.7 ohm,1/16W,J,1005,R/TP		
6	R212	INDUCTOR,CHIP	ELCH0010401	2.2 uH,M ,1005 ,R/TP ,		
6	R213	RES,CHIP	ERHY0000201	0 ohm,1/16W,J,1005,R/TP		
6	R215	RES,CHIP	ERHY0000202	4.7 ohm,1/16W,J,1005,R/TP		
6	R216	RES,CHIP	ERHY0000296	1M ohm,1/16W,J,1005,R/TP		

12. EXPLODED VIEW & REPLACEMENT PART LIST

Level	Location No.	Description	Part Number	Specification	Color	Remark
6	R217	RES,CHIP	ERHY0000244	1.5K ohm,1/16W,J,1005,R/TP		
6	R218	RES,CHIP	ERHY0000280	100K ohm,1/16W,J,1005,R/TP		
6	R219	RES,CHIP	ERHY0000203	10 ohm,1/16W,J,1005,R/TP		
6	R220	RES,CHIP	ERHY0000203	10 ohm,1/16W,J,1005,R/TP		
6	R221	RES,CHIP	ERHY0000203	10 ohm,1/16W,J,1005,R/TP		
6	R222	RES,CHIP	ERHY0000203	10 ohm,1/16W,J,1005,R/TP		
6	R224	RES,CHIP	ERHY0000265	20K ohm,1/16W,J,1005,R/TP		
6	R226	RES,CHIP	ERHY0000201	0 ohm,1/16W,J,1005,R/TP		
6	R227	RES,CHIP	ERHY0000261	10K ohm,1/16W,J,1005,R/TP		
6	R228	RES,CHIP	ERHY0000201	0 ohm,1/16W,J,1005,R/TP		
6	R229	RES,CHIP	ERHY0000271	39K ohm,1/16W,J,1005,R/TP		
6	R235	RES,CHIP	ERHY0000254	4.7K ohm,1/16W,J,1005,R/TP		
6	R237	RES,CHIP	ERHY0000201	0 ohm,1/16W,J,1005,R/TP		
6	R238	RES,CHIP	ERHY0000274	51K ohm,1/16W,J,1005,R/TP		
6	R239	RES,CHIP	ERHY0000254	4.7K ohm,1/16W,J,1005,R/TP		
6	R242	RES,CHIP	ERHY0000274	51K ohm,1/16W,J,1005,R/TP		
6	R301	RES,CHIP	ERHY0000261	10K ohm,1/16W,J,1005,R/TP		
6	R304	RES,CHIP	ERHY0000280	100K ohm,1/16W,J,1005,R/TP		
6	R305	RES,CHIP	ERHY0000280	100K ohm,1/16W,J,1005,R/TP		
6	R306	RES,CHIP	ERHY0000280	100K ohm,1/16W,J,1005,R/TP		
6	R307	RES,CHIP	ERHY0000280	100K ohm,1/16W,J,1005,R/TP		
6	R308	RES,CHIP	ERHY0000280	100K ohm,1/16W,J,1005,R/TP		
6	R309	RES,CHIP	ERHY0000237	680 ohm,1/16W,J,1005,R/TP		
6	R310	RES,CHIP	ERHY0000237	680 ohm,1/16W,J,1005,R/TP		
6	R313	RES,CHIP	ERHY0000213	47 ohm,1/16W,J,1005,R/TP		
6	R315	RES,CHIP	ERHY0000244	1.5K ohm,1/16W,J,1005,R/TP		
6	R316	RES,CHIP	ERHY0000220	100 ohm,1/16W,J,1005,R/TP		
6	R317	RES,CHIP	ERHY0000237	680 ohm,1/16W,J,1005,R/TP		
6	R319	RES,CHIP	ERHY0000213	47 ohm,1/16W,J,1005,R/TP		
6	R320	RES,CHIP	ERHY0000213	47 ohm,1/16W,J,1005,R/TP		
6	R321	RES,CHIP	ERHY0000213	47 ohm,1/16W,J,1005,R/TP		
6	R323	RES,CHIP	ERHY0000213	47 ohm,1/16W,J,1005,R/TP		
6	R324	RES,CHIP	ERHY0000237	680 ohm,1/16W,J,1005,R/TP		
6	R325	RES,CHIP	ERHY0000213	47 ohm,1/16W,J,1005,R/TP		

12. EXPLODED VIEW & REPLACEMENT PART LIST

Level	Location No.	Description	Part Number	Specification	Color	Remark
6	R326	RES,CHIP	ERHY0000213	47 ohm,1/16W,J,1005,R/TP		
6	R327	RES,CHIP	ERHY0000213	47 ohm,1/16W,J,1005,R/TP		
6	R329	RES,CHIP	ERHY0000213	47 ohm,1/16W,J,1005,R/TP		
6	R330	RES,CHIP	ERHY0000237	680 ohm,1/16W,J,1005,R/TP		
6	R331	RES,CHIP	ERHY0000213	47 ohm,1/16W,J,1005,R/TP		
6	R334	RES,CHIP	ERHY0000241	1K ohm,1/16W,J,1005,R/TP		
6	R335	RES,CHIP	ERHY0000237	680 ohm,1/16W,J,1005,R/TP		
6	R336	RES,CHIP	ERHY0000265	20K ohm,1/16W,J,1005,R/TP		
6	R337	RES,CHIP	ERHY0000201	0 ohm,1/16W,J,1005,R/TP		
6	R338	RES,CHIP	ERHY0000201	0 ohm,1/16W,J,1005,R/TP		
6	R339	RES,CHIP	ERHY0000237	680 ohm,1/16W,J,1005,R/TP		
6	R340	RES,CHIP	ERHY0000237	680 ohm,1/16W,J,1005,R/TP		
6	R341	RES,CHIP	ERHY0000237	680 ohm,1/16W,J,1005,R/TP		
6	R342	RES,CHIP	ERHY0000237	680 ohm,1/16W,J,1005,R/TP		
6	R343	RES,CHIP	ERHY0000237	680 ohm,1/16W,J,1005,R/TP		
6	R352	RES,CHIP	ERHY0007007	15 ohm,1/8W ,F ,2012 ,R/TP		
6	R353	RES,CHIP	ERHY0000241	1K ohm,1/16W,J,1005,R/TP		
6	R355	RES,CHIP	ERHY0000116	1.5K ohm,1/16W,F,1005,R/TP		
6	R356	RES,CHIP	ERHY0000273	47K ohm,1/16W,J,1005,R/TP		
6	R357	RES,CHIP	ERHY0000261	10K ohm,1/16W,J,1005,R/TP		
6	R358	RES,CHIP	ERHY0000261	10K ohm,1/16W,J,1005,R/TP		
6	R359	RES,CHIP	ERHY0000207	20 ohm,1/16W,J,1005,R/TP		
6	R370	RES,CHIP	ERHY0000220	100 ohm,1/16W,J,1005,R/TP		
6	R399	RES,CHIP	ERHY0000274	51K ohm,1/16W,J,1005,R/TP		
6	R404	RES,CHIP	ERHY0000262	12K ohm,1/16W,J,1005,R/TP		
6	R405	RES,CHIP	ERHY0000261	10K ohm,1/16W,J,1005,R/TP		
6	R406	RES,CHIP	ERHY0000287	220K ohm,1/16W,J,1005,R/TP		
6	R421	RES,CHIP	ERHY0000274	51K ohm,1/16W,J,1005,R/TP		
6	R488	RES,CHIP	ERHY0000247	2.2K ohm,1/16W,J,1005,R/TP		
6	R500	RES,CHIP	ERHY0000263	15K ohm,1/16W,J,1005,R/TP		
6	R501	RES,CHIP	ERHY0000220	100 ohm,1/16W,J,1005,R/TP		
6	R502	RES,CHIP	ERHY0000220	100 ohm,1/16W,J,1005,R/TP		
6	R503	RES,CHIP	ERHY0006603	36 ohm,1/16W ,J ,1005 ,R/TP		
6	R504	RES,CHIP	ERHY0000223	150 ohm,1/16W,J,1005,R/TP		

12. EXPLODED VIEW & REPLACEMENT PART LIST

Level	Location No.	Description	Part Number	Specification	Color	Remark
6	R505	RES,CHIP	ERHY0000223	150 ohm,1/16W,J,1005,R/TP		
6	R506	RES,CHIP	ERHY0000210	30 ohm,1/16W,J,1005,R/TP		
6	R507	RES,CHIP	ERHY0000224	180 ohm,1/16W,J,1005,R/TP		
6	R508	RES,CHIP	ERHY0000224	180 ohm,1/16W,J,1005,R/TP		
6	R512	RES,CHIP	ERHY0000201	0 ohm,1/16W,J,1005,R/TP		
6	R514	RES,CHIP	ERHY0000220	100 ohm,1/16W,J,1005,R/TP		
6	R515	RES,CHIP	ERHY0000201	0 ohm,1/16W,J,1005,R/TP		
6	R516	RES,CHIP	ERHY0000263	15K ohm,1/16W,J,1005,R/TP		
6	R517	RES,CHIP	ERHY0000201	0 ohm,1/16W,J,1005,R/TP		
6	R701	RES,CHIP	ERHY0000206	18 ohm,1/16W,J,1005,R/TP		
6	R702	RES,CHIP	ERHY0000206	18 ohm,1/16W,J,1005,R/TP		
6	R703	RES,CHIP	ERHY0000262	12K ohm,1/16W,J,1005,R/TP		
6	R704	RES,CHIP	ERHY0000241	1K ohm,1/16W,J,1005,R/TP		
6	R705	RES,CHIP	ERHY0000241	1K ohm,1/16W,J,1005,R/TP		
6	R706	RES,CHIP	ERHY0000262	12K ohm,1/16W,J,1005,R/TP		
6	R707	RES,CHIP	ERHY0000512	10M ohm,1/16W,J,1608,R/TP		
6	R708	RES,CHIP	ERHY0000201	0 ohm,1/16W,J,1005,R/TP		
6	R709	RES,CHIP	ERHY0000254	4.7K ohm,1/16W,J,1005,R/TP		
6	R710	RES,CHIP	ERHY0000254	4.7K ohm,1/16W,J,1005,R/TP		
6	R711	RES,CHIP	ERHY0000280	100K ohm,1/16W,J,1005,R/TP		
6	R712	RES,CHIP	ERHY0000241	1K ohm,1/16W,J,1005,R/TP		
6	R713	RES,CHIP	ERHY0000203	10 ohm,1/16W,J,1005,R/TP		
6	SW500	CONN,RF SWITCH	ENWY0003001	STRAIGHT ,SMD ,0.6 dB,3.8X3.0X3.6T		
6	U100	IC	EUSY0181502	CSP BGA ,204 PIN,R/TP ,GSM/GPRS DIGITAL BASEBAND PROCESSOR / ART7TDMI DSP, Pb Free		
6	U101	IC	EUSY0169301	148-TERMINAL BGA ,148 PIN,R/TP ,GSM ANALOG BASEBAND / TYPHOON B, Pb Free		
6	U200	IC	EUSY0204801	SC82-AB (SC70-4) ,4 PIN,R/TP ,80mA CMOS LOW IQ LDO VOLTAGE REGULATOR / 2.5V		
6	U201	IC	EUSY0077701	SC70-5 ,5 PIN,R/TP ,1.8V Low Voltage Comparator with Rail-to-Rail Input, Pb Free		
6	U202	IC	EUSY0119001	10 uMAX ,10 PIN,R/TP ,DUAL SPDT ANALOG SWITCH, Pb Free		
6	U203	IC	EUSY0212401	BGA ,35 PIN,R/TP ,		
6	U204	IC	EUSY0077301	SC70-6 ,6 PIN,R/TP ,SPDT Analog switch		
6	U205	IC	EUSY0119001	10 uMAX ,10 PIN,R/TP ,DUAL SPDT ANALOG SWITCH, Pb Free		

12. EXPLODED VIEW & REPLACEMENT PART LIST

Level	Location No.	Description	Part Number	Specification	Color	Remark
6	U206	IC	EUSY0149701	LLP ,10 PIN,R/TP ,1 Watt Audio Power Amplifier / Leadless Type		
6	U300	IC	EUSY0250201	BGA ,88 PIN,R/TP ,128T+32ps(MLC) 8X10		
6	U400	IC	EUSY0238201	QFN ,16 PIN,R/TP ,3 LEDs, WHITE LED CHARGE PUMP		
6	U401	IC	EUSY0118602	SOT23 ,5 PIN,R/TP ,2.85V/150mA Low Noise uCap LDO Regulator, PBFREE		
6	U500	IC	EUSY0161301	8x8 LGA ,28 PIN,R/TP ,		
6	U501	PAM	SMPY0008901	35 dBm,55 % 2 A,-50 dBc,25 dB,6.0 * 6.0 * 1.4 ,SMD ,GSM QUAD PAM		
6	U700	IC	EUSY0227301	BCC32++ ,32 PIN,R/TP ,FM stereo radio IC		
6	U701	IC	EUSY0220901	LDA10A ,10 PIN,R/TP ,Dual 105mW Headphone Amplifier		
6	U702	IC	EUSY0118602	SOT23 ,5 PIN,R/TP ,2.85V/150mA Low Noise uCap LDO Regulator, PBFREE		
6	VA202	VARISTOR	SEVY0004001	18 V ,SMD ,3pF, 1005		
6	VA203	VARISTOR	SEVY0004001	18 V ,SMD ,3pF, 1005		
6	VA204	VARISTOR	SEVY0004001	18 V ,SMD ,3pF, 1005		
6	VA300	CAP,CERAMIC,CHIP	ECCH0004904	1 uF,6.3V ,K ,X5R ,TC ,1005 ,R/TP		
6	VA301	RES,VARIABLE,ETC	ERVZ0000101	ohm, PIN, ,SMD ,R/TP ,1005 SIZE CHIP VARISTOR, Pb Free		
6	VA302	VARISTOR	SEVY0001001	14 V ,SMD ,50pF, 1005		
6	VA303	VARISTOR	SEVY0001001	14 V ,SMD ,50pF, 1005		
6	VA304	VARISTOR	SEVY0001001	14 V ,SMD ,50pF, 1005		
6	VA305	VARISTOR	SEVY0001001	14 V ,SMD ,50pF, 1005		
6	VA306	VARISTOR	SEVY0001001	14 V ,SMD ,50pF, 1005		
6	VA307	VARISTOR	SEVY0001001	14 V ,SMD ,50pF, 1005		
6	VA308	VARISTOR	SEVY0001001	14 V ,SMD ,50pF, 1005		
6	VA309	VARISTOR	SEVY0001001	14 V ,SMD ,50pF, 1005		
6	VA310	VARISTOR	SEVY0001001	14 V ,SMD ,50pF, 1005		
6	VA311	VARISTOR	SEVY0001001	14 V ,SMD ,50pF, 1005		
6	VA330	VARISTOR	SEVY0001001	14 V ,SMD ,50pF, 1005		
6	VA331	VARISTOR	SEVY0001001	14 V ,SMD ,50pF, 1005		
6	VA332	VARISTOR	SEVY0001001	14 V ,SMD ,50pF, 1005		
6	VA333	VARISTOR	SEVY0001001	14 V ,SMD ,50pF, 1005		
6	X100	X-TAL	EXXY0015601	.032768 MHz,20 PPM,7 pF,65000 ohm,SMD ,6.9*1.4*1.3 ,		
6	X200	X-TAL	EXXY0015601	.032768 MHz,20 PPM,7 pF,65000 ohm,SMD ,6.9*1.4*1.3 ,		

12. EXPLODED VIEW & REPLACEMENT PART LIST

Level	Location No.	Description	Part Number	Specification	Color	Remark
6	X500	VCTCXO	EXSK0006501	13 MHz,2 PPM,10 pF,SMD ,3.2*2.5*1.2 ,SV 2.85V, AFC 0.8V		
5	SAFD	PCB ASSY,MAIN,SMT TOP	SAFD0046002			
6	C201	CAP,CERAMIC,CHIP	ECCH0000120	39 pF,50V,J,NP0,TC,1005,R/TP		
6	C202	CAP,TANTAL,CHIP,MAKER	ECTZ0005201	10 uF,6.3V ,M ,L_ESR ,1608 ,R/TP		
6	C209	CAP,CERAMIC,CHIP	ECCH0000120	39 pF,50V,J,NP0,TC,1005,R/TP		
6	C210	CAP,CERAMIC,CHIP	ECCH0000120	39 pF,50V,J,NP0,TC,1005,R/TP		
6	C211	CAP,CERAMIC,CHIP	ECCH0000182	0.1 uF,10V ,K ,X5R ,HD ,1005 ,R/TP		
6	C213	CAP,CERAMIC,CHIP	ECCH0000120	39 pF,50V,J,NP0,TC,1005,R/TP		
6	C214	CAP,CERAMIC,CHIP	ECCH0000120	39 pF,50V,J,NP0,TC,1005,R/TP		
6	C298	VARISTOR	SEVY0001001	14 V, ,SMD ,50pF, 1005		
6	C318	CAP,CERAMIC,CHIP	ECCH0004904	1 uF,6.3V ,K ,X5R ,TC ,1005 ,R/TP		
6	C319	CAP,CERAMIC,CHIP	ECCH0004904	1 uF,6.3V ,K ,X5R ,TC ,1005 ,R/TP		
6	C320	CAP,CERAMIC,CHIP	ECCH0004904	1 uF,6.3V ,K ,X5R ,TC ,1005 ,R/TP		
6	C321	CAP,CERAMIC,CHIP	ECCH0004904	1 uF,6.3V ,K ,X5R ,TC ,1005 ,R/TP		
6	C322	CAP,CERAMIC,CHIP	ECCH0004904	1 uF,6.3V ,K ,X5R ,TC ,1005 ,R/TP		
6	C323	CAP,CERAMIC,CHIP	ECCH0004904	1 uF,6.3V ,K ,X5R ,TC ,1005 ,R/TP		
6	C324	CAP,CERAMIC,CHIP	ECCH0000182	0.1 uF,10V ,K ,X5R ,HD ,1005 ,R/TP		
6	C400	CAP,CERAMIC,CHIP	ECCH0004904	1 uF,6.3V ,K ,X5R ,TC ,1005 ,R/TP		
6	C489	CAP,CERAMIC,CHIP	ECCH0004904	1 uF,6.3V ,K ,X5R ,TC ,1005 ,R/TP		
6	CN400	CONNECTOR,BOARD TO BOARD	ENBY0018701	41 PIN,0.3 mm,STRAIGHT , ,0.9t stacking height		
6	LD300	DIODE,LED,CHIP	EDLH0004502	BLUE ,1608 ,R/TP ,0.35T		
6	LD301	DIODE,LED,CHIP	EDLH0004502	BLUE ,1608 ,R/TP ,0.35T		
6	LD302	DIODE,LED,CHIP	EDLH0004502	BLUE ,1608 ,R/TP ,0.35T		
6	LD303	DIODE,LED,CHIP	EDLH0004502	BLUE ,1608 ,R/TP ,0.35T		
6	LD304	DIODE,LED,CHIP	EDLH0004502	BLUE ,1608 ,R/TP ,0.35T		
6	LD305	DIODE,LED,CHIP	EDLH0004502	BLUE ,1608 ,R/TP ,0.35T		
6	LD306	DIODE,LED,CHIP	EDLH0007901	RED ,1608 ,R/TP ,Indicator,0.4T Red LED		
6	R200	RES,CHIP	ERHY0000241	1K ohm,1/16W,J,1005,R/TP		
6	R203	RES,CHIP	ERHY0000247	2.2K ohm,1/16W,J,1005,R/TP		
6	R207	RES,CHIP	ERHY0000220	100 ohm,1/16W,J,1005,R/TP		
6	R208	RES,CHIP	ERHY0000201	0 ohm,1/16W,J,1005,R/TP		
6	R210	RES,CHIP	ERHY0000220	100 ohm,1/16W,J,1005,R/TP		
6	R214	RES,CHIP	ERHY0000247	2.2K ohm,1/16W,J,1005,R/TP		

12. EXPLODED VIEW & REPLACEMENT PART LIST

Level	Location No.	Description	Part Number	Specification	Color	Remark
6	R344	RES,CHIP	ERHY0000213	47 ohm,1/16W,J,1005,R/TP		
6	R345	RES,CHIP	ERHY0000213	47 ohm,1/16W,J,1005,R/TP		
6	R346	RES,CHIP	ERHY0000213	47 ohm,1/16W,J,1005,R/TP		
6	R347	RES,CHIP	ERHY0000213	47 ohm,1/16W,J,1005,R/TP		
6	R348	RES,CHIP	ERHY0000213	47 ohm,1/16W,J,1005,R/TP		
6	R349	RES,CHIP	ERHY0000213	47 ohm,1/16W,J,1005,R/TP		
6	R350	RES,CHIP	ERHY0000239	820 ohm,1/16W,J,1005,R/TP		
6	R400	RES,CHIP	ERHY0000274	51K ohm,1/16W,J,1005,R/TP		
6	R401	RES,CHIP	ERHY0000274	51K ohm,1/16W,J,1005,R/TP		
6	R402	RES,CHIP	ERHY0000274	51K ohm,1/16W,J,1005,R/TP		
6	VA200	RES,VARIABLE,ETC	ERVZ0000101	ohm, PIN, ,SMD ,R/TP ,1005 SIZE CHIP VARISTOR, Pb Free		
6	VA201	RES,VARIABLE,ETC	ERVZ0000101	ohm, PIN, ,SMD ,R/TP ,1005 SIZE CHIP VARISTOR, Pb Free		
5	SPFY00	PCB,MAIN	SPFY0095301	FR-4 , 1.0 mm,BUILD-UP 8 ,		

12. EXPLODED VIEW & REPLACEMENT PART LIST

12.3 Accessory

Note: This Chapter is used for reference, Part order is ordered by SBOM standard on GCSC

Level	Location No.	Description	Part Number	Specification	Color	Remark
3	MHBY00	HANDSTRAP	MHBY0002101	T5100 RUSSV Square Coupling, Cow Leather	Metal Silver	
3	SBPL00	BATTERY PACK,LI-ION	SBPL0077901	3.7 V,830 mAh,1 CELL,PRISMATIC ,FG101 RUSSV423450, Innerpack	Without Color	
3	SGEY00	EAR PHONE/EAR MIKE SET	SGEY0003503	FG101 ,STERO,Y TYPE 16OHM		
3	SSAD00	ADAPTOR,AC-DC	SSAD0007828	100-240V ,60 Hz,5.2 V,800 mA,CE,CB,GOST ,EU PLUG(24P),STD		