



---

## **SITE TECHNICAL DOCUMENTATION**

### **myX-2**

---

---

**Doc. No. : SCT U38 SSC DTS 0013**

**Version : A**

**Date : October 22 , 2003**

---

Produced by **SAGEM SA**  
2, rue du Petit Albi, 95800 Cergy Saint-Christophe, France  
Tel (33) 1 30 73 50 50 - Fax (33) 1 30 73 50 55

Copyright © 2002  
SAGEM  
Cergy Saint-Christophe, France

## **NO DISCLOSURE AGREEMENT**

This document is SAGEM SA property. It can not be copied or communicated in all or part without written authorisation.

---

## CONTENTS

### CHAPTER 1 - FOREWORD

1.1 HOW TO USE THE SITE TECHNICAL DOCUMENTATION.....	1-1
1.2 ABBREVIATIONS .....	1-2
1.3 COMMENTS SHEET.....	1-3

### CHAPTER 2 - DESCRIPTION - OPERATION

2.1 REMINDERS ABOUT THE GENERAL CHARACTERISTICS OF GSM AND PCS NETWORKS.....	2-1
2.2 REMINDERS ABOUT myX-2 CHARACTERISTICS .....	2-3
2.3 SMK CONNECTOR.....	2-6
2.3.1 Connector description.....	2-6
2.3.2 Signal description .....	2-6
2.4 IDENTIFICATION .....	2-7
2.4.1 Illustration.....	2-7
2.4.2 Description.....	2-7
2.4.3 Description after reparation .....	2-7
2.5 PHONE BLOCK DIAGRAM.....	2-8
2.5.1 myX-2 block diagram .....	2-8
2.5.2 Standards and environment.....	2-8
2.6 EQUIPEMENTS.....	2-9
2.6.1 Battery packs .....	2-9
2.6.2 Mains modules.....	2-10

### CHAPTER 3 - SYMPTOMS

3.1 GENERAL.....	3-1
3.2 LIST OF REPORTED DEFECTS .....	3-2
3.3 ERROR MESSAGES DURING START UP .....	3-4
3.4 OTHER ERROR MESSAGES .....	3-4
3.5 LIST OF OBSERVED DEFECTS .....	3-6
<b>SYMPTOM SHEET</b> .....	3-7
SYMPTOM SHEET 01 : ENDURANCE BATTERY CHARGER.....	3-8
SYMPTOM SHEET 02 : COMMUNICATION.....	3-9
SYMPTOM SHEET 03 : NO FAULT GIVEN.....	3-10
SYMPTOM SHEET 04 : DISPLAY.....	3-11

---

SYMPTOM SHEET 05 : KEYPAD.....	3-12
SYMPTOM SHEET 06 : RING TONES.....	3-13
SYMPTOM SHEET 07 : VIBRATE.....	3-14
SYMPTOM SHEET 08 : MICROPHONE / LOUDSPEAKER.....	3-15

## **CHAPTER 4 - TESTS AND CHECKS**

4.1 GENERAL ABOUT TESTS .....	4-1
4.2 TEST TOOLS .....	4-1
4.3 INSTALLING ON A WORKSTATION .....	4-2
4.3.1 Minimum required configuration .....	4-2
4.3.2 Installing the CRA downloading kit .....	4-2
4.3.3 SMT functions .....	4-2
<b>TEST SHEET</b> .....	<b>4-3</b>
TEST SHEET 01 : TEST CHECK BY SMT .....	4-4
TEST SHEET 02 : CHARGER TEST.....	4-13
TEST SHEET 03 : BATTERY TEST.....	4-14
TEST SHEET 04 : CONSUMPTION TEST.....	4-15
TEST SHEET 05 : "HOTLINE" MENU .....	4-16
TEST SHEET 06 : RADIO TEST.....	4-17

## **CHAPTER 5 – MAINTENANCE PROCEDURES**

5.1 TECHNICAL WORK LEVELS .....	5-1
5.2 SHORT LOOP PROCEDURE .....	5-2
5.3 MAINTENANCE TOOLS .....	5-4
<b>LEVEL 0 MAINTENANCE</b> .....	<b>5-5</b>
PROCEDURE SHEET 0 01 : REMOVING AND REPLACING THE BACK COVER.....	5-6
PROCEDURE SHEET 0 02 : REMOVING AND REPLACING THE BATTERY .....	5-8
PROCEDURE SHEET 0 03 : REMOVING AND REPLACING THE FRONT COVER.....	5-10
PROCEDURE SHEET 0 04 : REMOVING AND REPLACING THE KEYPAD.....	5-12

<b>LEVEL 1 MAINTENANCE</b> .....	<b>5-14</b>
PROCEDURE SHEET 1 02 : REMOVING AND REPLACING THE DISPLAY.....	5-15
PROCEDURE SHEET 1 03 : REMOVING AND REPLACING THE LIGHT GUIDE KEYPAD.....	5-17
PROCEDURE SHEET 1 04 : REMOVING AND REPLACING THE ELECTRONIC BOARD.....	5-19
PROCEDURE SHEET 1 05 : REMOVING AND REPLACING THE METAL DOME.....	5-21
PROCEDURE SHEET 1 06 : REMOVING AND REPLACING THE SIM LOCKER.....	5-23
PROCEDURE SHEET 1 07 : REMOVING AND REPLACING THE BATTERY CONNECTOR.....	5-25
PROCEDURE SHEET 1 08 : REMOVING AND REPLACING THE MICROPHONE.....	5-27
PROCEDURE SHEET 1 09 : REMOVING AND REPLACING THE LOUDSPEAKER/ VIBRATING DEVICE.....	5-29
PROCEDURE SHEET 1 11 : ELECTRONIC BOARD EXCHANGE.....	5-31
<b>LEVEL 3 MAINTENANCE</b> .....	<b>5-34</b>
PROCEDURE SHEET 3 01 : RETURN TO SAGEM FACTORY.....	5-36
PROCEDURE SHEET 3 02 : RETURN TO CUSTOMER.....	5-37
<b>OUT OF WARRANTY INTERVENTION</b> .....	<b>5-38</b>
PROCEDURE SHEET 4 01 : REMOVING AND REPLACING THE SMK CONNECTOR.....	5-39

## CHAPTER 6 - ACCESSORIES

6.1 12 V / 24 V CHARGERS.....	6-1
6.1.1 Description .....	6-1
6.1.2 Characteristics .....	6-1
6.2 DESKTOP CHARGERS AND CRADLES .....	6-2
6.2.1 Description.....	6-2
6.2.2 Characteristics .....	6-2
6.3 CAR CRADLE.....	6-3
6.3.1 Description .....	6-3
6.3.2 Characteristics .....	6-3
6.4 FULL DUPLEX CAR HANDSFREE KIT .....	6-4
6.4.1 Description .....	6-4
6.4.2 Characteristics .....	6-4
6.5 PEDESTRIAN HANDSFREE KIT .....	6-6
6.5.1 Description .....	6-6
6.5.2 Characteristics .....	6-6
6.6 DATA CABLES .....	6-7
6.6.1 Description .....	6-7
6.6.2 Characteristics .....	6-7

**CHAPTER 7 – TECHNICAL INFORMATION BULLETIN**

7.1 PURPOSE .....	7-1
7.2 APPLICATION .....	7-1

**CHAPTER 8 – ILLUSTRATED PARTS CATALOG**

8.1 myX-2 SPARE PARTS .....	8-1
-----------------------------	-----

**APPENDIX 1 – COMPOSITION TABLE**

## CHAPTER 1 - FOREWORD

This document is common to all phones in the SAGEM. It is composed of independent sheets:

- Symptom sheets = Symp Sheet XX
- Test and check sheet = Test Sheet XX
- Maintenance procedure sheet = Proc Sheet X XX

The applicability of a procedure is indicated in the independent sheets title block:

- All types = GSM 850/900, GSM 1800/1900 and dual band.

These sheets are updated from time to time in Technical Information Bulletins (TIB).

The information contained in this document is non-contractual, since phone characteristics can change.

Phones are managed based on SAGEM handset codes; any order for spare parts must refer to these codes (typical code 25 xxx xxx-x).

### 1.1 HOW TO USE THE SITE TECHNICAL DOCUMENTATION

This is a modular document. Each sheet is unique and independent. In some cases several sheets may have to be used in order to determine the complete procedure to be applied.

A troubleshooting chapter (chapter 3) is provided and is sorted according to the type of reported fault, to determine the maintenance procedure to be carried out.

These sheets describe the procedure to be followed. They refer to test sheets or removal and replacement maintenance sheets. Maintenance ,executed by the repair center, terminates either by returning the product to the customer, or by dispatching it to level 3 maintenance (return to factory).

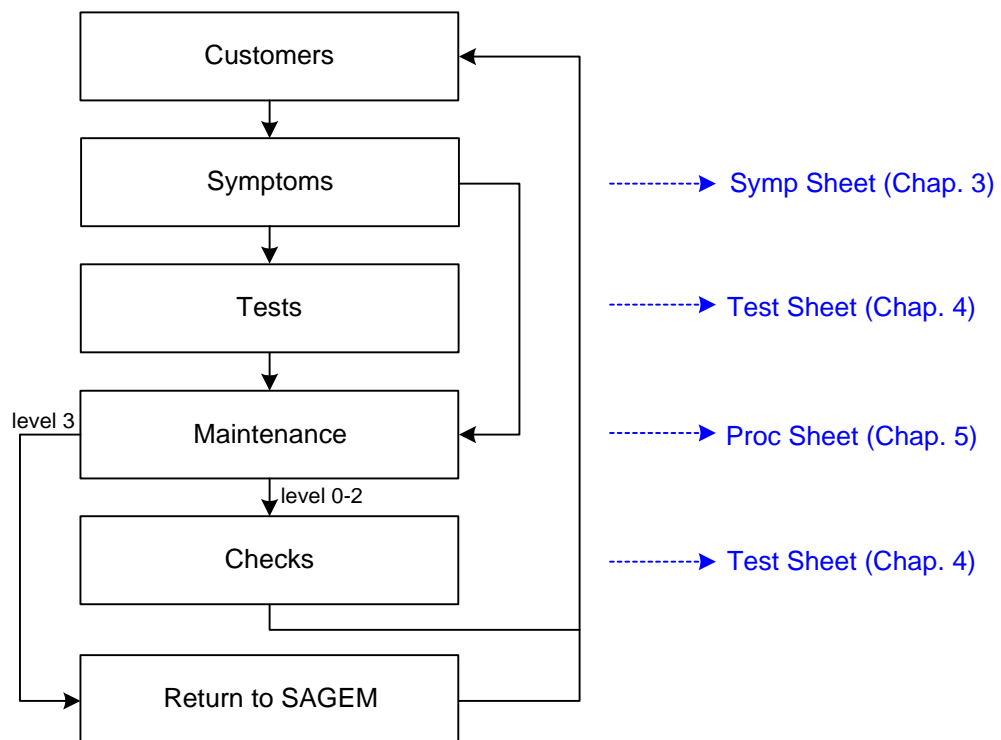

All sheets include illustrations to make it easier to read the procedure.

- **Chapter 1 : Foreword**, describes general data about this document.
- **Chapter 2 : Description - Operation**, describes general data and options available in the myX-2.
- **Chapter 3 : Symptoms**, contains troubleshooting procedures to be carried out on equipment.
- **Chapter 4 : Tests and checks**, contains tests and check procedures to be performed on the equipment.
- **Chapter 5 : Maintenance procedures**, contains level 0 to 2 maintenance procedures to be carried out on the equipment, and the procedure to return to SAGEM level 3.
- **Chapter 6 : Accessories**, describes the characteristics of accessories for myX-2 phones .
- **Chapter 7 : Technical Information Bulletins**, contains the various modifications made to this documentation.
- **Chapter 8 : Illustrated Parts Catalogue**, contains the various reference for spare parts.
- **Appendix 1: Composition table**, contains the various SAGEM references codes for equipment described in this document.

## 1.2 ABREVIATIONS

AAC	Advanced Audio Codeur
ADPCM	Adaptive Differential Pulse Codec Modulation
ALS	Alternative Line Services
AOC	Advice Of Charge
CCD	Charged Coupled Device
CLI	Calling Line Identification
CLIP	Calling Line Identification Presentation
DCS	Digital Cellular System
EFR	Enhanced Full Rate
EMS	Enhanced Message Service
FDN	Fixe Dial Number
GPRS	General Packet Radio Service
GSM	Global System for Mobile
IMEI	International Mobile Equipment Identity
ISO	International Standard Organisation
LU	Livret d'Utilisation
MMS	Multimedia Message Service
PCS	Personnal Communication Service
PIN	Personal Identity Number
PUK	PIN Unlocking Key
SAR	Specific Absortion Rate
SIM	Subscriber Identify Module
SMS	Short Message Service



SMS CB	Short Service Message Cell Broadcast
SMT	Sagem Mobiles Tools
TFT	Thin Film Transistors
USSD	Unstructured Supplementary Service Data
VGA	Video Graphics Array
WAP	Wireless Application Protocol
WSP	Wireless Session Protocol

### **1.3 COMMENTS SHEET**

Broad experience is very beneficial in several respects. Please let us know your comments so that we can improve the contents and presentation of this document.

Your suggestions will be read carefully by :

- the design laboratory,
- production,
- the purchasing department,
- the after sales service,
- all users of this document.

All your suggestions are valuable, they will help us to better satisfy you.

Please photocopy and fill in the sheet 1-4.

Document title: **Site Technical Document for myX-2**

Reference : **SCT U38 SSC DTS 0013**

Date : July 2003

Please fill in the following table :

	<b>Excellent</b>	<b>Good</b>	<b>Fairly good</b>	<b>Passable</b>
Easy to find the required information				
Clarity of information provided				
Quality and accuracy of information given				
Document outline				
Document presentation and appearance				
Quality of illustrations				
General satisfaction				

Do you think this document could be improved ? if so, how ? :

- $\pi$  Improve the overall view
- $\pi$  Improve the table of contents
- $\pi$  Improve the structure
- $\pi$  Add illustrations
- $\pi$  Add details
- $\pi$  Add information

Comments : \_\_\_\_\_  
\_\_\_\_\_

Would you like to discuss the problems mentioned in this questionnaire? If so, state :

Name of the person to be contacted : \_\_\_\_\_ Phone : \_\_\_\_\_

Company : \_\_\_\_\_ Date : \_\_\_\_\_

Address : \_\_\_\_\_

**THANK YOU FOR PARTICIPATING IN THIS ENQUIRY. YOUR COMMENTS WILL HELP US CONTINUE TO IMPROVE THE QUALITY OF OUR DOCUMENTATION AND THUS BETTER SATISFY YOUR NEEDS.**

When you have filled in this questionnaire, please send it :

**SAGEM S.A.**  
Support Service Client / URD 38  
2 rue du petit Albi  
BP 8250  
95801 Cergy Saint-Christophe  
FRANCE

## CHAPTER 2 - DESCRIPTION - OPERATION

### 2.1 REMINDERS ABOUT THE GENERAL NETWORKS CHARACTERISTICS

Table 1 below gives the characteristics of the radio interface for the GSM 850 / 900, GSM 1800 and GSM 1900 systems :

	<b>GSM 850</b>	<b>GSM 900</b>	<b>GSM 1800</b>	<b>PCS 1900</b>
Frequency Band (MHz)	824 - 849 869 - 894	890 - 915 925 - 960	1710 - 1785 1805 - 1880	1850 - 1910 1930 - 1990
Number of time intervals per TDMA frame	8			
Width 2 x W simplex (MHz)	2 x 25	2 x 25	2 x 75	2 x 60
Duplex spacing (MHz)	45	45	95	80
Modulation speed (kbit/s)	271			
Speech throughput (kbit/s)	13 (5,6)			
Maximum data throughput (kbit/s)	12			
Multiple access	Frequency and temporal multiplexing / frequency duplexing			
Cell radius (km)		0,3 to 30	0,1 to 4	0,1 to 4
SAGEM terminal power (W)	2	2	1	1

**Table 1 : Radio Interface**

Table 2 shows powers as a function of the network :

Class number	<b>GSM 850 / 900</b>		<b>GSM 1800</b>		<b>PCS 1900</b>	
	Maximum nominal power (W)	Allowable interval (W)	Maximum nominal power (W)	Allowable interval (W)	Maximum nominal power (W)	Allowable interval (W)
1	-	-	1	[0,63 ; 1,6]	1	
2	8	[5,0 ; 12,7]	0,25	[0,16 ; 0,4]	0,25	
3	5	[3,2 ; 7,9]	4	[2,5 ; 6,3]	2	
4	2	[1,3 ; 3,2]				
5	0,8	[0,5 ; 1,3]				

**Table 2: Terminals power class**

Table 3 shows power classes :

	Class 1	Class 2	Class 3	Class 4	Class 5
GSM 850 / 900	43 dBm	39 dBm	37 dBm	33 dBm	29 dBm
GSM 1800	30 dBm	24 dBm	36 dBm	-	-
GSM 1900	30 dBm	24 dBm	33 dBm	-	-

**Table 3: RF power classes**

## 2.2 REMINDERS ABOUT THE CHARACTERISTICS AND OPTIONS OF myX-2

**Remark:** This information is given for guidance, and is in no way contractual characteristics vary according to customers and countries.

<b>GENERAL CHARACTERISTICS</b>	
<b>Size</b>	
Dimension (LxWxH, mm)	99,4x44,8x20,5 mm
Weight (g)	89g
Volume (cm3)	76,6 cm3
<b>Power Management</b>	
Battery type	Liion 860 mAh
Charging time	3 h
Talk time (TW.09)	5 h
Data Mode time	Not Applicable
Standby time (TW.09)	340 h
<b>Display and User Interface</b>	
Screen type	CSTN
Colours	256
Number of lines	up to 8 lines
Screen size LxH (mm)	29,3x25,3 mm
Screen resolution (pixels)	101x80 pixels
Backlight	yes
Soft keys / navigation	two
Sub LCD (clam design)	No
<b>Customisation</b>	
Handset colours	5 colours
Interchangeable covers	Yes Front and Back
<b>Radio</b>	
GSM Band	850 / 900 / 1800 / 1900 MHz depending on model
Automatic switching between bands	Yes
Voice codecs	HR, FR, EFR
<b>Operating System</b>	
<b>CONNECTIVITY</b>	
<b>Radio</b>	
GPRS	No
UMTS	No
<b>Internet</b>	
Browser	Wap 1,2
Push	Yes
Built-in data / fax Modem	No
<b>Data Transfer</b>	
Serial	External accessory cable
IrDA (Obex or other standard)	No
Bluetooth	No
USB	External accessory cable
WiFi (802.11b,a)	No
PC/MAC directory synchronisation	Accessory :via cable and Welphone software for PC
<b>MULTIMEDIA</b>	
<b>Messaging</b>	
SMS	MO/MT/CB
EMS	Yes release 5
MMS	No
Instant messaging (IMPS) - Chat	No

<b>MULTIMEDIA (cont'd)</b>	
Notification	Yes
Predictive text input	T9
<b>Video &amp; Images</b>	
Camera	No
Image features	No
Video Player	No
Image Format	bmp, jpeg, png, gif icons
<b>Audio</b>	
Audio Recorder	No
Audio player	Yes for ringtones
Polyphonic ringtones	8 tones
Audio formats	iMelody, Midi , Wave , HiFi
<b>Entertainment</b>	
Wallpaper	Up to 30 (14 to download through Wap)
Screensaver	animated, up to 5 ( 3 to download through Wap)
Clock display	Yes
Icons	up to 40(10 to download through Wap)
Embedded Games	One game
Java	No
<b>OTA Downloads</b>	
Protocol supported	EMS,WSP-Get,WAP save as , Download Fun and M Services
Wallpaper / screensaver	Up to 240 kB of shared memory
Animation	Up to 240 kB of shared memory
Menu icon	Up to 240 kB of shared memory
Games	Not applicable
Ringtone	Up to 240 kB of shared memory
Music	Up to 240 kB of shared memory
Java application	Not applicable
<b>CALL MANAGEMENT</b>	
<b>Voice features</b>	
Mute mode	Yes
Integrated handsfree mode	Yes
<b>Address book features</b>	
Call group	Yes
Personal information management (V-card)	No
Ringtone / Icone customisation	Yes
<b>Advanced Features</b>	
Conference call	Yes
Call list (dialed, received and missed)	Yes
Caller ID	Yes
Anonymous mode	Yes
Call wait / call hold / call transfer	Yes
Call forwarding	Yes
Sim toolkit	Yes
Vibrate mode	Yes
Speed dialing	voice mail only
Automatic redial	Yes
Any key answer	Yes
Automatic hang up	Yes
<b>SPECIAL FEATURES</b>	
<b>Keyboard Features</b>	
Scroll key	4 ways Navigator
Direct access key (ADN, SMS, WAP, i-mode)	2 programmable keys
Keypad lock	Yes
Silent key	Yes
International access key	No

<b>SPECIAL FEATURES (cont'd)</b>	
<b>Personal Management Features</b>	
Calculator	Yes
Alarm Clock	Yes
Stop watch	Yes
Organizer	No
To Do	No
Voice recorder	No
Currency converter	Yes
Languages	set of 4 languages (Factory settings)
<b>Compatible Accessories</b>	
Data cord	Serial, USB
Universal charger	Yes
Hands free kit	Yes
<b>MEMORY</b>	
Internal phone book (positions)	250
Messaging memory SMS/EMS/MMS/Email (positions)	100
Redial list (positions)	20
Additional multimedia memory	Yes Up to 240 kB of shared memory
Embedded memory (Max size for total user objects)	Yes Up to 240 kB of shared memory

## 2.3 SMK CONNECTOR

### 2.3.1 Connector description

This connector is located at the bottom of the transmission module and enable the connection to various accessories. It comprises power supply pins and signals.

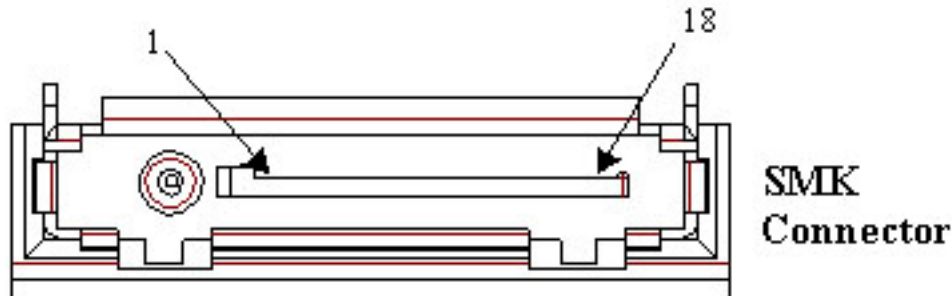

### 2.3.2 Signal description

SYMBOL	PIN No.	SIGNAL FUNCTION	NATURE E/S, AI, Ana
CHARGER	1	Phone set power ON and power supply signal.	POWER SUPPLY
VBAT	2	POWER SUPPLY IMAGE VOLTAGE, connect this signal to «CHARGER» (pin n°1) to switch the module on.	POWER SUPPLY OUTPUT
ON*	3	SIGNAL RESERVED FOR USE BY SAGEM (car handsfree kit).	OPEN DRAIN OUTPUT
VPP	4	Flash programming voltage	POWER SUPPLY
SDAI2C	5	DATA SIGNAL RESERVED FOR SAGEM SPECIFIC ACCESSORIES.	LOGICAL INPUT/OUTPUT
GND	6	ZERO VOLT	SIGNAL GROUND
SCLI2C	7	CLOCK SIGNAL RESERVED FOR SAGEM SPECIFIC ACCESSORIES.	OPEN DRAIN INPUT/OUTPUT
INTI2C	8	INTERRUPT SIGNAL RESERVED FOR SAGEM SPECIFIC ACCESSORIES.	LOGICAL INPUT
POLANT32 (RXD2)	9	APPLICATION INPUT SERIAL N°2	LOGICAL INPUT
RXDG	10	SERIAL DATA TO BE TRANSMITTED.	LOGICAL INPUT
TXDG	11	SERIAL DATA RECEIVED.	LOGICAL OUTPUT
DIN32	12	RESET	LOGICAL INPUT
ITDATA	13	Interruption signal keep for SAGEM accessories.	LOGICAL INPUT
GND	14	ZERO VOLT.	SIGNAL GROUND
BFRXP	15	Audio frequency signal received ( $\phi 0$ ).	ANALOG OUTPUT
BFRXN	16	Complementary output to BFRXP ( $\phi 180$ ).	ANALOG OUTPUT
BFTXN	17	AUDIO FREQUENCY SIGNAL TO BE TRANSMITTED $\phi 180$ . Complementary input to BFTXP.	ANALOG INPUT
BFTXP	18	AUDIO FREQUENCY SIGNAL TO BE TRANSMITTED $\phi 0$ . Acoustic L.F. signal to be transmitted.	ANALOG INPUT



## 2.4 IDENTIFICATION

All phones are identified with an identification label stuck on the antenna.

### 2.4.1 Illustration

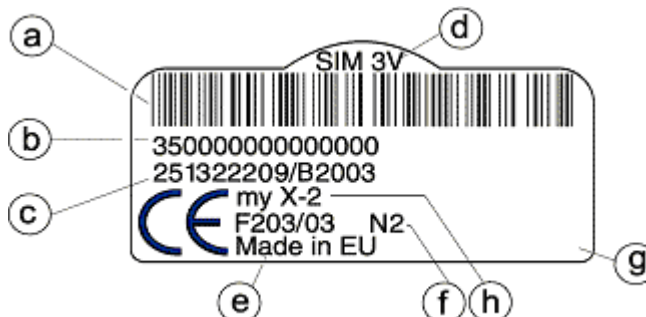

### 2.4.2 Description

- a : IMEI (bar code),
- b : IMEI (15 characters)
- c : Reference of product / aesthetic used .
- d : Sim card Indication (Sim 3V...),
- e : Production area Indication,
- f : Date code + Manufacturing level,  
 Ex. F203/03 = (F) fabrication area (F : Fougères), (203) day of year, (03) last digit of year (03→2003).
- g : Logo and agreement.
- h : Product designation

### 2.4.3 Description after repair

A new sticker is positioning by Repairing Centre near the sim card connector:



This extra line will appear if the mobile has already been repaired.

- **CRA XXX** ⇒ N° of CRA,
- **203/N03** ⇒ Date of repair: (203) repairing day, (03) last digit of year (03→2003).

## 2.5 PHONE BLOCK DIAGRAM

### 2.5.1 myX-2 block diagram

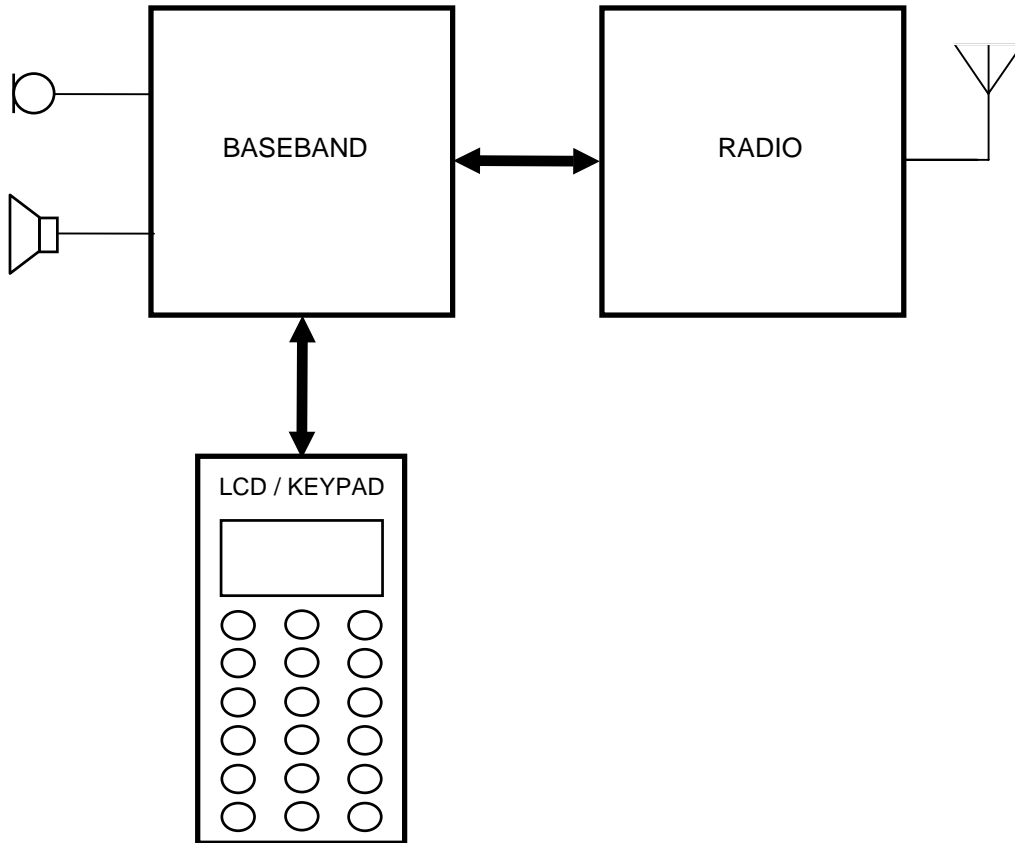

### 2.5.2 Standards and environment

#### Conformance Document

SAGEM SA declare under its sole responsibility that the product Dual Band GSM/DCS Type B2003 conforms to the

requirements of the following EEC directives:

<b>EEC Directive</b>	1999/5/CE
<b>Safety</b>	EN 60950
<b>EMC</b>	EN 301 489-1 / EN 301 489-7
<b>Low voltage directive</b>	73/23/CEE
<b>Network</b>	3GPP TS 51.010-1 v 5.2.0 selected with GCF-CC v 3.10.0 included
<b>Requirements</b>	GT01 v 4.7.0 / TBR 19 Edition 5 / TBR 20 Edition 3 / TBR 31 Edition 2 TBR 32 Edition 2 / EN 301 419-1 / EN 301511
<b>Health</b>	EN 50360 / EN 50361

## 2.6 EQUIPEMENTS

The description and operation of SAGEM myX-2 are given in the "User's handbook" supplied with the phone. This chapter only describes equipment that operates with the myX-2 phones .

### 2.6.1 Battery packs

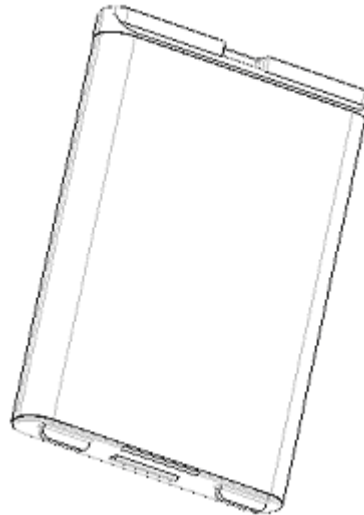

Over view

#### 2.6.1.1 Characteristics

Type	Technology	Weight	Voltage capacity
L860	Li-Ion	24 g	3,6 V / 860 mA/H

#### 2.6.1.2 Description

Li-ion type batteries are used. They are rechargeable using:

- mains power supply modules,
- 12 V / 24 V, cigar lighter chargers,
- car handsfree kits (compact and comfort),
- Power supply data.

#### **Batteries caution use:**

- Store the batteries in a dry and cool place (excessive cold and heat damage the batteries reliability).
- They must never be stored in bulk, even the rejects, to avoid any short circuits.
- Do not dismantle the battery packs. (Li-Ion regulations).
- Only use original mains power supply module.
- **All the out of order batteries must be returned to SAGEM.**

2.6.1.3 Charging time

The following table shows typical charging times for different batteries.

Battery	500 mA travel chargers	AC* and K** chargers	"Simple" unregulated chargers 230 V Nom. (110 V Nom.)	
			230 V (110 V)	254 V (121 V)
	94 V à 254 V			
L860	2h45	3 h	3h45	3h20

\* : cigar lighter chargers (12 V et 24 V)

\*\* : car handsfree kits (Values screen off).

**2.6.2 Mains modules**

2.6.2.1 Description

These mains power supply modules accept large dynamic variations in the power supply network. They are available for a number of connector types:

- E.U,
- United Kingdom
- United States,
- Australia.

2.6.2.2 Travel mains modules

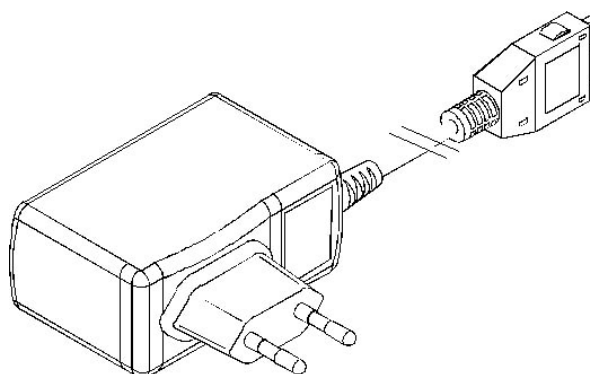

Designation	Weight (g)	Vol (cm <sup>3</sup> )	Primary voltage
<i>UNREGULATED TRAVEL MAINS POWER SUPPLY MODULES 6.5 V. 500 mA.</i>			
TRAVEL 500 mA. EC	100	75	110/230 V
TRAVEL 500 mA. UK	110	90	110/230 V
TRAVEL 500 mA. US	125	65	110/230 V
TRAVEL 500 mA. AUS	100	75	110/230 V

2.6.2.3 Mains modules

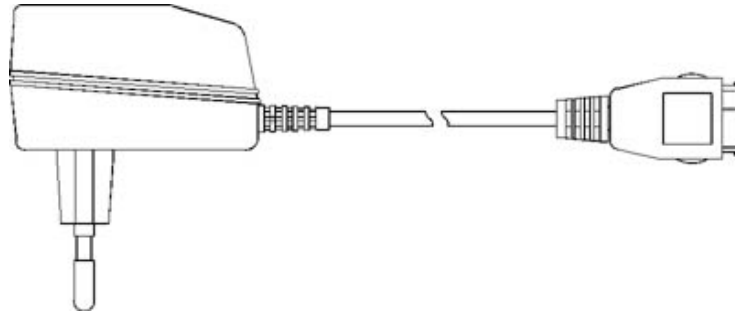

Reference	Weight (g)	Vol (cm <sup>3</sup> )	Primary voltage
<i>SIMPLE UNREGULATED MAINS POWER SUPPLY MODULES 1.5 V. 300 mA.</i>			
EC MAINS MODULE	180	85	230 V
UK MAINS MODULE	180	120	230 V
US MAINS MODULE	210	105	110 V
AUS MAINS MODULE	190	105	230 V

## CHAPTER 3 - SYMPTOMS

### 3.1 GENERAL

After you have received the **customer return sheet** ([Proc Sheet 3 02](#)), carry out the troubleshooting procedure.

This chapter will help you to identify the defective element(s), using the troubleshooting table. It contains flow charts broken down by fault type. Each flow chart describes the procedure to be followed and contains cross references to tests or maintenance.

These flow charts should be followed in full. After a reference to a removal/replacement sheet or to a test to be carried out, you should return to the initial flow chart and continue the search until reaching a final conclusion.

The conclusion of each troubleshooting procedure is :

- Return to SAGEM =The Return to the SAGEM centre can concern either the card, or the radiotelephone according to instructions given to the Centres of repair.
- Delivery to the customer

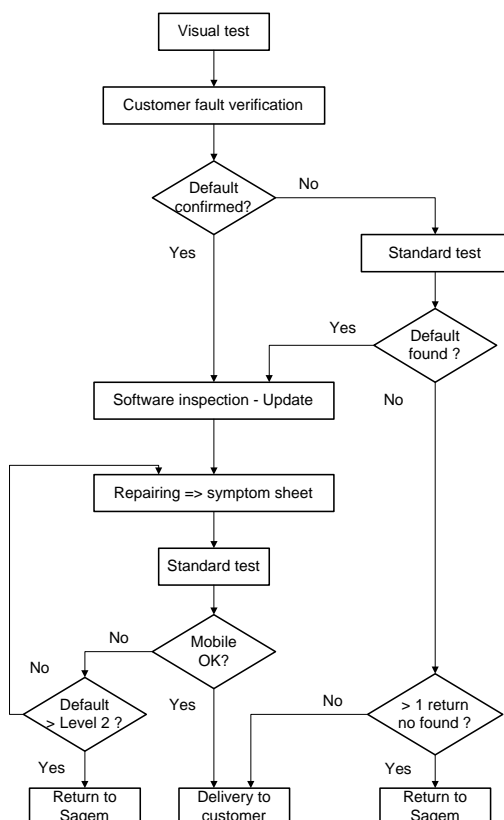

#### Visual test :

- Glass state
- Keypad state (elastomer, inscription)
- Connector state (SMK, battery, SIM)
- Plug and position of battery
- SIM card position
- Oxidation

#### Standard test :

- Display test : Hot Line menu
- Contrast control
- All keypad keys test (check bips keys)
- Audio and radio test
- Battery charge test
- Consumption of mobile in off state
- Vibrating device test : Hot Line menu
- Charger test
- Real call with a operator SIM card

#### Software inspection :

For all mobiles to repair, the checking by SMT is **mandatory** ([Test Sheet 01](#)).

### 3.2 LIST OF REPORTED DEFECTS

The following is a list of defects that may be reported :

<i>Code</i>	<i>Indicated fault</i>	<i>Procedure</i>
A0	Display malfunction	Symp Sheet 04
A1	No power up	Proc Sheet 1 10 or 3 01
A2	No display up	Symp Sheet 04
A3	Freezes up	Proc Sheet 1 10 or 3 01
A4	Back lights problem	Proc Sheet 1 10 or 3 01
A5	Broken LCD	Symp Sheet 04
A6	Line or digit missing	Symp Sheet 04
B0	Power supply / no charge	Symp Sheet 01
B1	Defective battery contact	Proc Sheet 0 02
B2	Defective charger connector	Proc Sheet 1 10 or 3 01
B3	Defective board power supply	Proc Sheet 1 10 or 3 01
B4	Defective charge icon display	Proc Sheet 1 10 or 3 01
B5	Current consumption with phone off	Test Sheet 04
B7	Autonomy	Symp Sheet 01
B8	Electrically defective battery	Test Sheet 03
B9	Mechanical lock problem on battery	Proc Sheet 0 02
B10	Broken battery	Test Sheet 03
B11	Defective charger	Test Sheet 02
B12	Broken charger	Test Sheet 02
B13	Intermittent cut with reboot	Proc Sheet 1 10 or 3 01
B14	Intermittent cut without reboot	Proc Sheet 1 10 or 3 01
C1	Not functioning keyboard	Symp Sheet 05
C2	Lateral key problem	Symp Sheet 05
D1	Sim missing	Proc Sheet 1 10 or 3 01
D2	Other messages	Proc Sheet 1 10 or 3 01
D3	EEPROM pb	Proc Sheet 1 10 or 3 01
D4	Untuned mobile	Proc Sheet 1 10 or 3 01
D5	Hard failure	Proc Sheet 1 10 or 3 01
D6	Sim lock	Proc Sheet 1 10 or 3 01
D7	Post code	Test Sheet 01
D8	Return SAV	Proc Sheet 1 10 or 3 01
D9	Unknown battery	Test Sheet 03

<i>Code</i>	<i>Indicated fault</i>	<i>Procedure</i>
E1	Defective loudspeaker (hails)	<a href="#">Symp Sheet 08</a>
E2	Loudspeaker voice distortion	<a href="#">Symp Sheet 08</a>
E3	Defective microphone	<a href="#">Symp Sheet 08</a>
E4	Microphone voice distortion	<a href="#">Symp Sheet 08</a>
E5	Vibrating device malfunction	<a href="#">Symp Sheet 07</a>
E6	Defective audio connector	<a href="#">Symp Sheet 08</a>
F1	No network localisation	<a href="#">Symp Sheet 02</a>
F2	Intermittent calls drop	<a href="#">Symp Sheet 02</a>
F3	Network temporary drop	<a href="#">Proc Sheet 1 10 or 3 01</a>
F4	Radio test not ok	<a href="#">Proc Sheet 1 10 or 3 01</a>
F5	Outgoing call failure	<a href="#">Symp Sheet 02</a>
F6	Incoming call failure	<a href="#">Symp Sheet 02</a>
G1	Broken or damaged glass	<a href="#">Proc Sheet 0 01</a>
G2	Broken or damaged cover	<a href="#">Proc Sheet 0 01 /0 03</a>
G5	Broken or damaged keyboard	<a href="#">Proc Sheet 0 04</a>
H1	DATA PROBLEM (SMS, EMS, SMS,GPRS, WAP, DOWNLOADING GAMES, RINGING TONES, SCREEN SAVER, NO COMMUNICATION WITH A PC, POCKET PC or PALM)	<a href="#">Test sheet 01</a>
H2	Video function	<a href="#">Without object</a>
H3	INFRARED function (IRDA)	<a href="#">Without object</a>
I1	Oxidation marks	<a href="#">Proc Sheet 1 10 or 3 01</a>
I2	FM function	<a href="#">Proc Sheet 1 10 or 3 01</a>
I3	Monetic function	<a href="#">Proc Sheet 1 10 or 3 01</a>
I4	Broken or damaged accessory	<a href="#">Proc Sheet 1 10 or 3 01</a>
I5	Defective SIM connector	<a href="#">Proc Sheet 1 10 or 3 01</a>
I6	Malfunction of the menu	<a href="#">Test sheet 01</a>
I7	Lack function in the menu	<a href="#">Test sheet 01</a>
I8	No fault found	<a href="#">Symp sheet 03</a>



### 3.3 ERROR MESSAGES DURING START UP

<i>Message</i>	<i>Meaning</i>	<i>Procedure</i>
WARNING RADIO UNTUNED	Invalid EEPROM field (SAGEM)	SAGEM Factory Return
PB IMEI	Consistency problem at IMEI level	SAGEM Factory Return
SIM MISSING	SIM card missing or badly inserted	Insert the SIM card
IMEI ERROR	Consistency problem at IMEI level	SAGEM Factory Return
UNTUNED	Mobile not configured	SAGEM Factory Return
UNKNOWN BATTERY	Battery not recognised by the mobile	Replace the battery
MOBILE PHONE LOCKED	Number of seizures of sim locked code exceeded	SAGEM Factory Return Not repair under warranty
SIM BLOCKED	Three bad PIN codes have been input	Contact the operator
SIM LOCKED (with SIM)	SIM card not adapted to the operator	Replace the SIM card
SIM LOCKED (without SIM)	Attempt of corruption ( EEPROM fields)	SAGEM Factory Return Not repair under warranty
BATTERY TOO LOW	Battery state	Replace the battery

### 3.4 OTHER ERROR MESSAGES

<i>Message</i>	<i>Meaning</i>
"LINE INCIDENT"	Fax & PC link type "Problems"
"FULL MEMORY"	Fax & PC link type "Problems"
"CLEARING REJECTED"	Fax & PC link type "Problems"
"CHECK CONNECTION"	Fax & PC link type "Problems"
"NOT CONSULTED DOCUMENT"	Fax & PC link type "Problems"
"DEVICE PROBLEM"	Fax & PC link type "Problems"
"VERIFY APPLICATION"	Fax & PC link type "Problems"
"BUSY"	"Problems" related to the network and Communications
"K.PAD LOCKED PRESS *V"	Keypad locked
"OPTION NOT AVAILABLE"	Menu not available for this product version
"PROG.KEY NOT VALID"	Input "Problems"
"ERROR!!"	Calculation error with the calculator (division by zero)
"NOT REACHABLE"	Call forwarding if the mobile is not reachable
"NOT AVAIL."	Not available
"PIN ERROR"	" PIN input problems "
"PIN2 BLOCKED"	Following input errors
"PUK ERROR"	Following input errors

<b>Message</b>	<b>Meaning</b>
"PUK2 BLOCKED"	Following input errors
"CODE ERROR"	The phone code input for locking the mobile is incorrect
"NOT AVAIL."	Service not implemented in the network
"TRY AGAIN"	Following a network problem
"NETWORK BUSY"	"Problems" related to the network and Communications
"WAIT"	"Problems" related to the network and Communications
"UNBLOCK?"	"Problems" related to the SIM card
"MEMO REC. CUT"	Save during storage in the answering machine truncated due to lack of space
"FUNCTION NOT ALLOWED"	Prohibited function requested
"NOT FOUND"	Unsuccessful search (on directory, etc.)
"BUSY"	"Problems" related to the network and Communications
"REJECTED"	The requested operation was refused by the network
"EMPTY"	Empty (note pad, memo, etc.)
"NOT IN GROUP"	Error display following an error code returned from the network (CUG menus)
"CREDIT END"	"Credit end" information (paying call prohibited)
"CREDIT TOO LOW"	"Credit too low" information (CUG menus)
"NO AUTHORIZED ACTION DURING A WAP CALL"	Not available action during a wap call
"NOT CONFIGURED ACCESS"	Selection of a not configured provider
"UNKNOWN ACCESS"	Selection of a not fully configured provider
"UNKNOWN CALL IN PROGRESS"	Selection of a provider during a call in progress
"NO RESPONSE OF THE SERVER"	"Problems" related to the server
"NO RESPONSE OF THE NETWORK"	"Problems" related to the network and Communications
"NOT AVAILABLE NETWORK"	"Problems" related to the network and Communications
"TOO LONG URL ADDRESS"	The address typed is too long

### **3.5 LIST OF OBSERVED DEFECTS**

A SAGEM code is assigned to each confirmed defect. This code should be entered on **Proc Sheet 3 01, SAGEM Factory Return**, if the phone to be repaired is returned to SAGEM (see chapter 5).

# **SYMPTOM SHEETS**

	<b>ENDURANCE, BATTERY, CHARGER PROBLEM</b>	Symp Sheet 01
myX-2		1/1

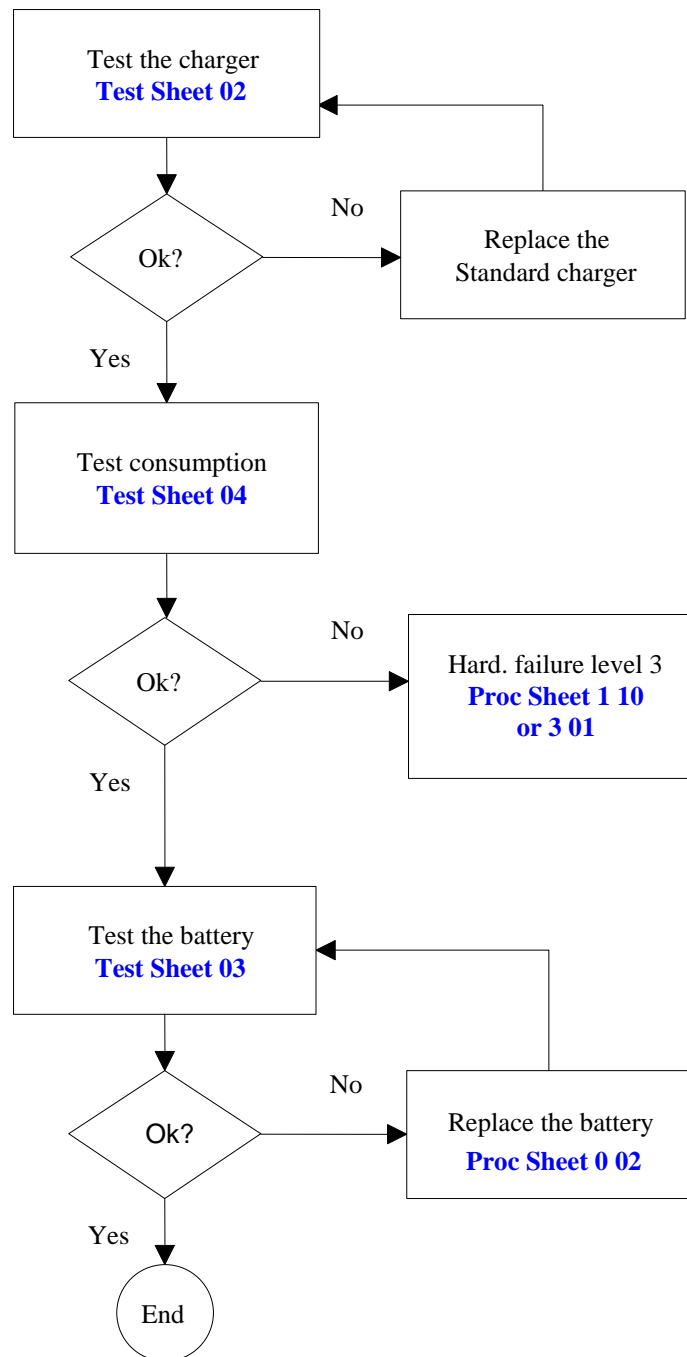

	<b>COMMUNICATION PROBLEM</b>	Symp Sheet 02
myX-2		1/1

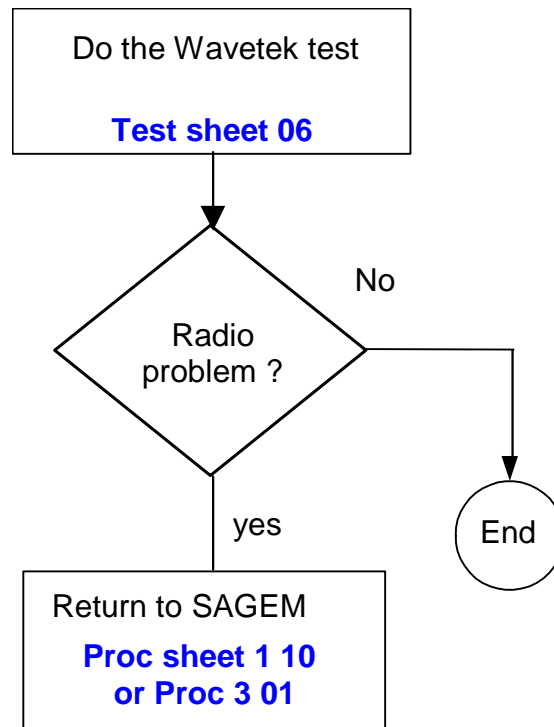

	<b>NO FAULT GIVEN</b>	Symp Sheet 03
myX-2	<b>(Expertise of the phone)</b>	1/1

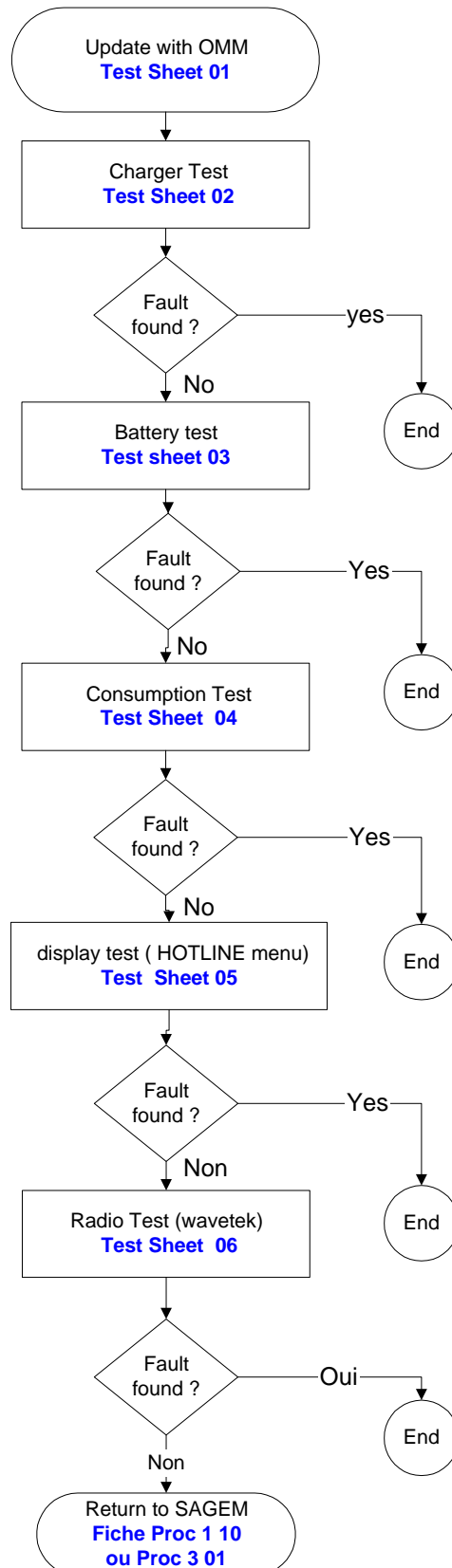

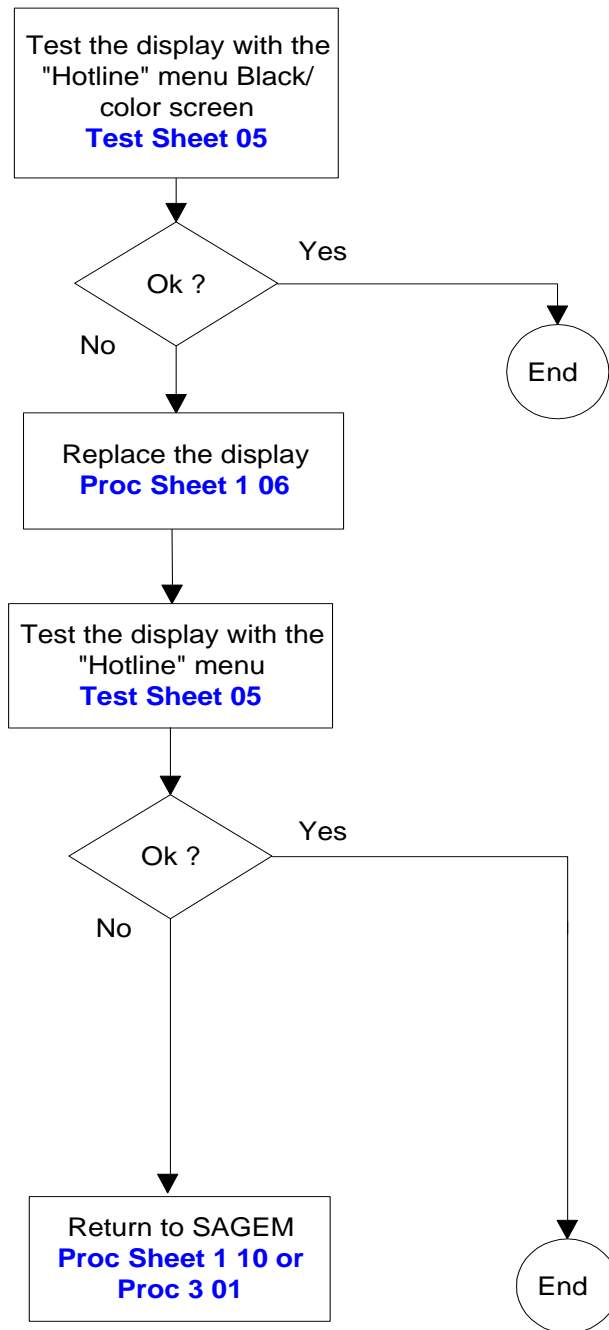

	<b>DISPLAY PROBLEM</b>	Symp Sheet 04
myX-2		1/1



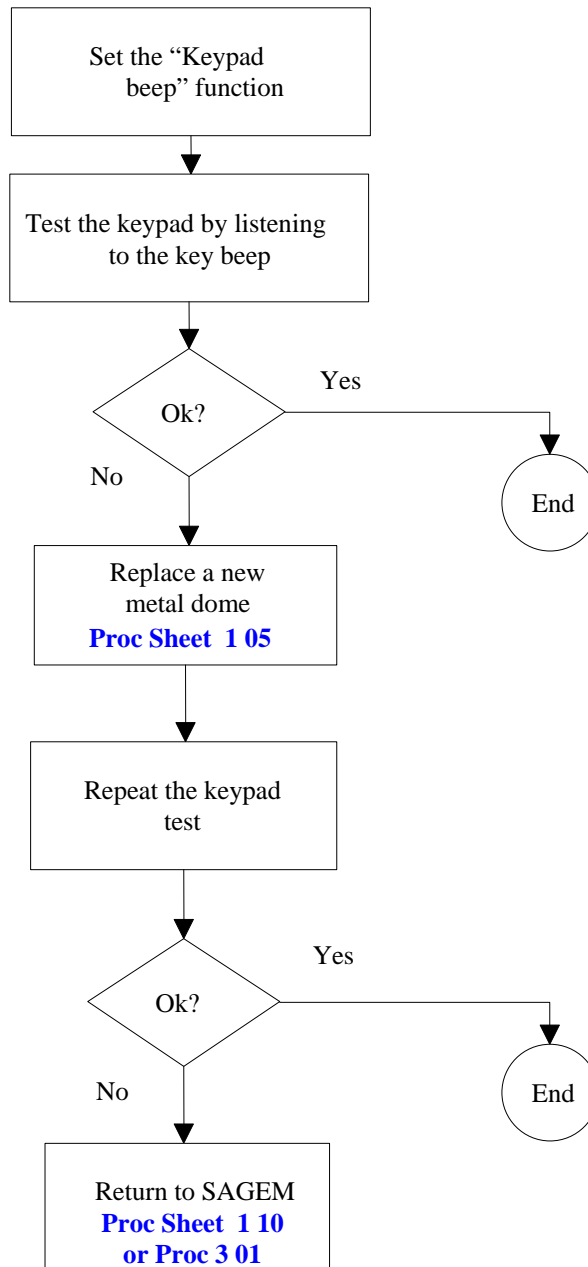

	<b>KEYPAD PROBLEM</b>	Symp Sheet 05
myX-2		1/1



	<b>RING TONES PROBLEM</b>	Symp Sheet 06
myX-2		1/1

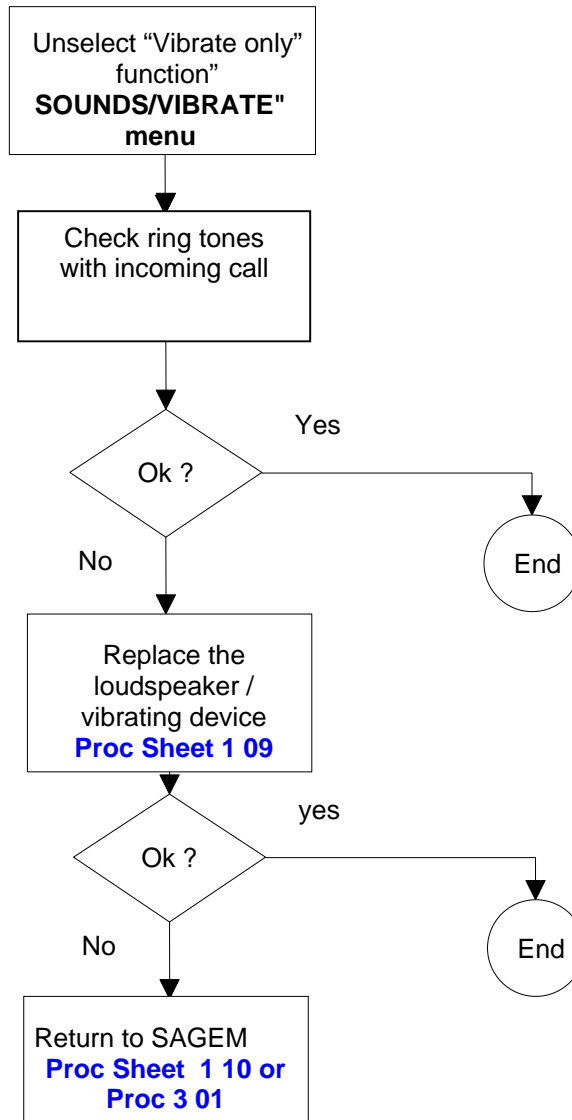

	<b>VIBRATING DEVICE</b>	Symp Sheet 07
myX-2		1/1

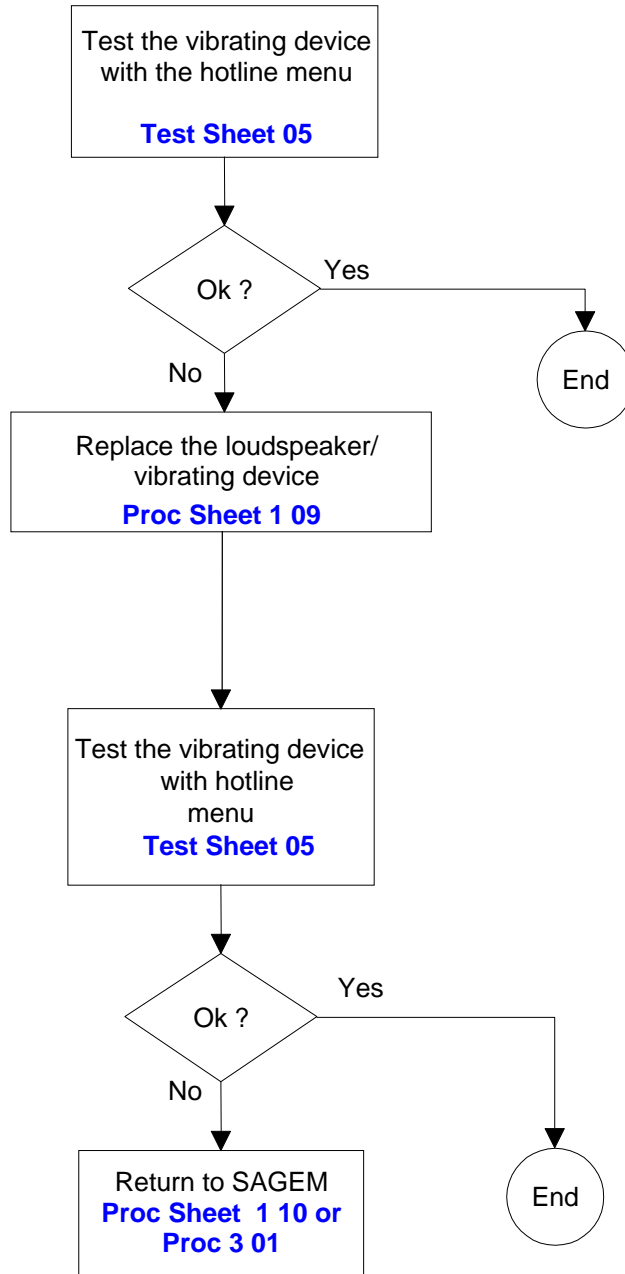

	<b>MICROPHONE OR LOUDSPEAKER PROBLEM</b>	Symp Sheet 08
myX-2		1/1

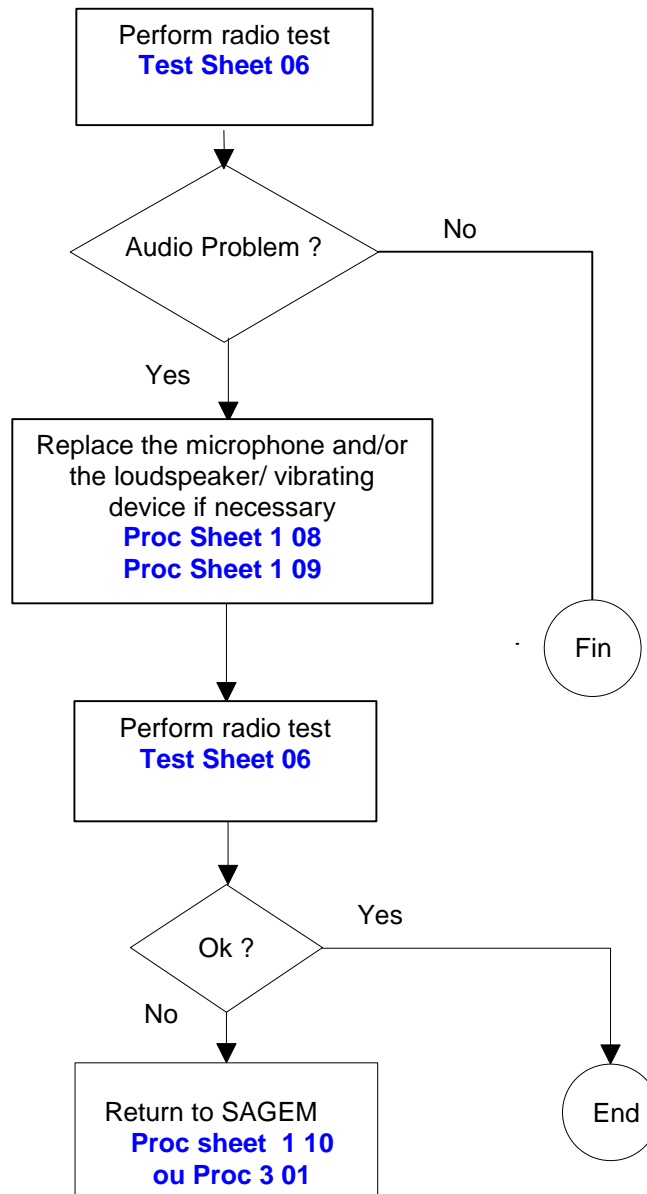

---

## CHAPTER 4 - TESTS AND CHECKS

### 4.1 ABOUT TESTS

Tests and checks are made after the troubleshooting procedures (chapter 3) and before the maintenance procedures (chapter 5).

They are broken down into modules and are sorted by types of confirmed faults. The user must be equipped with special test tools in order to carry out the tests.

### 4.2 TEST TOOLS

The references of SAGEM tools, listed hereafter, are given in Appendix 1 : Composition table.

The following test tools are necessary :

- a PC type computer,
- the SMT maintenance software for the myX-2
- the **ARC downloading kit**, including the test case provided with:
  - the data cable (to PC),
  - the "SMK" cable,
  - the mains power supply module.
- the **radio test bench**, provided with:
  - SIM card of test.
  - myX-2 radio interface
  - Adjustable regulate power supply 0-15V / 4A
  - Wavetek 4107
- **CADEX C7000 / C7200 / ASTRATEK** with myX-2 adapter
  - Charger test kit
  - Ammeter interface myX-2
  - Voltmeter (minimum impedance : 20 K $\Omega$  per Volt in DC)
  - Ammeter
- an **IMEI labels printing station**, including :
  - Printer,
  - Roll of labels,
  - Connecting cable for PC (parallel printer cable),
  - Printing software,

### **4.3 INSTALLING ON A WORKSTATION**

#### **4.3.1 Minimum required configuration**

The minimum configuration of the workstation is :

- Processor 1Ghz,
- 128 Mbytes of RAM,
- Windows (S.R2), Windows NT (SP 4), Windows 2000, Windows XP,
- 2.1 Gbytes hard disk (1 Gbytes available),
- 1 parallel port and 2 serials ports.
- network card, sound card.
- 1 internet access,

#### **4.3.2 Installing the ARC downloading kit**

The ARC downloading kit interfaces the SMT software with the phone to be repaired.

- Connect the 9-pin SUB-D connector to the PC serial port (COM1).
- Connect the power supply module to the mains power outlet.
- Connect the phone to be repaired to the SMK connector.

#### **4.3.3 SMT functions**

The SMT maintenance software can :

- Download new software if needed
- Configure default values and checks them.
- Unblocked the " POST CODE "
- Delete the customer directory and SMS
- Print identification labels.
- Make a electronic board exchange
- Adjust the display contrast
- Read the STD
- Select a test sequence

The procedures for using these functions are described in [TEST Sheet 01](#).

# TEST SHEET

	<b>TEST AND CHECK BY SMT</b>	Test Sheet 01    1/9
MyX-2		

To run the functions described below, run the SMT application from the desktop icon.

**Notice:** The active connection with SMT ( via the serial port ), validate in itself the data functionality of the handset.

***Download the latest software***

1. Click on the READ popup menu and then on INFORMATIONS.
2. Follow the procedures on the screen.
3. Make sure that the mobile phone is not in the sleep mode (press the Start key)

***Configure and check default values***

1. Click on the CONFIGURE popup menu and then VERIFY (Verfab).
2. Follow the procedures on the screen.

***Release the " POST CODE"***

1. Click on the CONFIGURE popup menu and then on RELEASE
2. Follow the procedures on the screen.

***Delete the customer directory and SMS***

1. Click on the CUSTOMER DATA popup menu and then ERASE DIRECTORY OR ERASE SMS.
2. Follow the procedures on the screen.

**Note :** There is possibility to save the directory when the ARC signed a confidential agreement.

***Print identification labels***

1. Click on the on LABEL popup menu and then PRINT LABEL .
2. Follow the procedures on the screen

▪ **Audio parameters setting**

1. Click on the AUDIO popup menu
2. Follow the procedures on the screen



	<b>TEST AND CHECK BY SMT</b>	Test Sheet 01    2/9
myX-2		

**SMT SEQUENCE : Series of the different functions under SMT ( sequence of tests)**

1. Click on SMT SEQUENCE popup menu.
2. Select the different functions you want to carry out then click on LAUNCH button.

▪ **Electronic board exchange**

1. Click on the SWAP popup menu , then SWAP
2. Follow the procedures on the screen

	<b>TEST AND CHECK BY SMT</b>	Test Sheet 01    3/9
myX-2		

**SWAP : Electronic board Configuration**

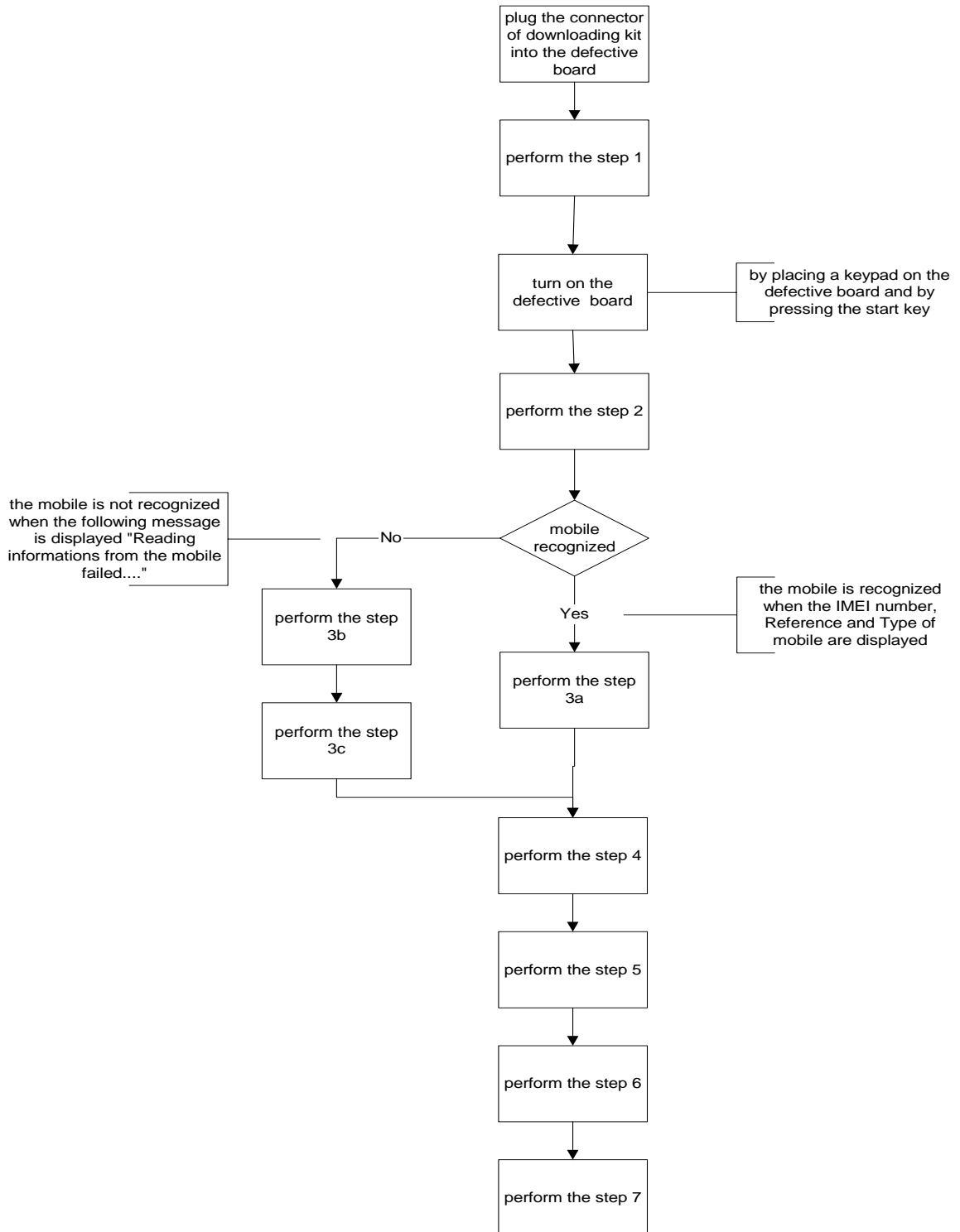

	<b>TEST AND CHECK BY SMT</b>	Test Sheet 01    4/9
myX-2		

**Step 1**

**SMT Front page**

**Click on the « SWAP Process » menu.**

**Example**

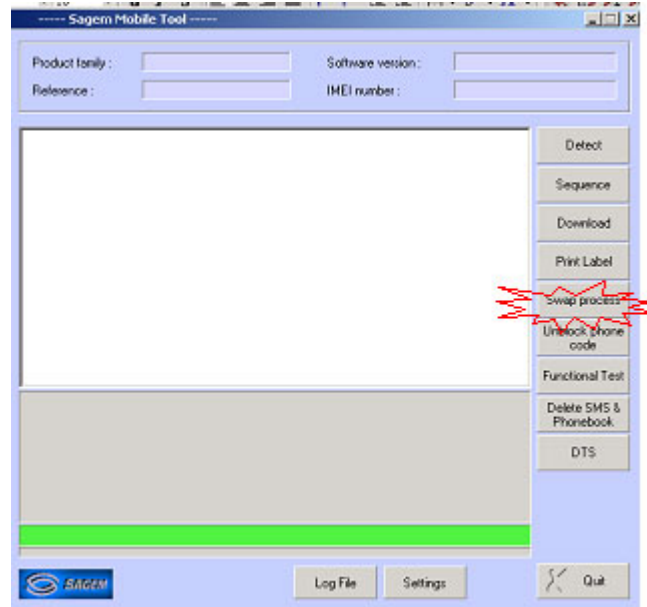

**The following screen appears :**

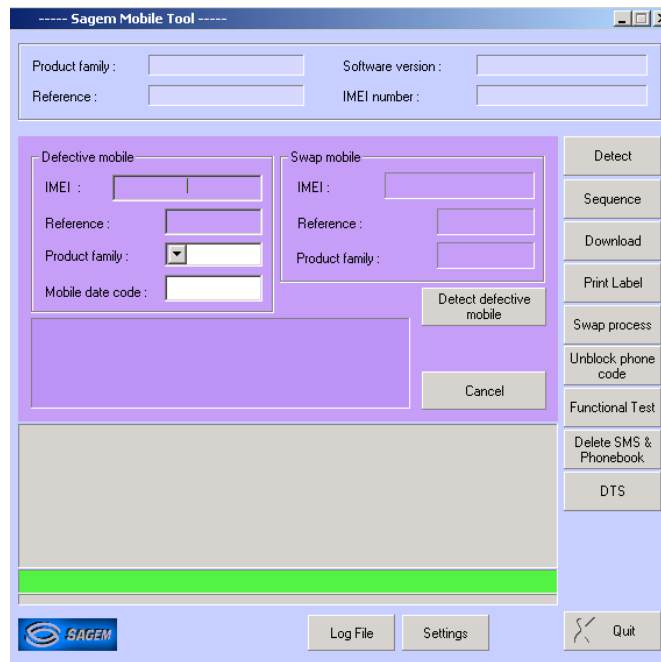

	<b>TEST AND CHECK BY SMT</b>	Test Sheet 01    5/9
myX-2		

### Step 2

**Please click on « Detect defective mobile » button**

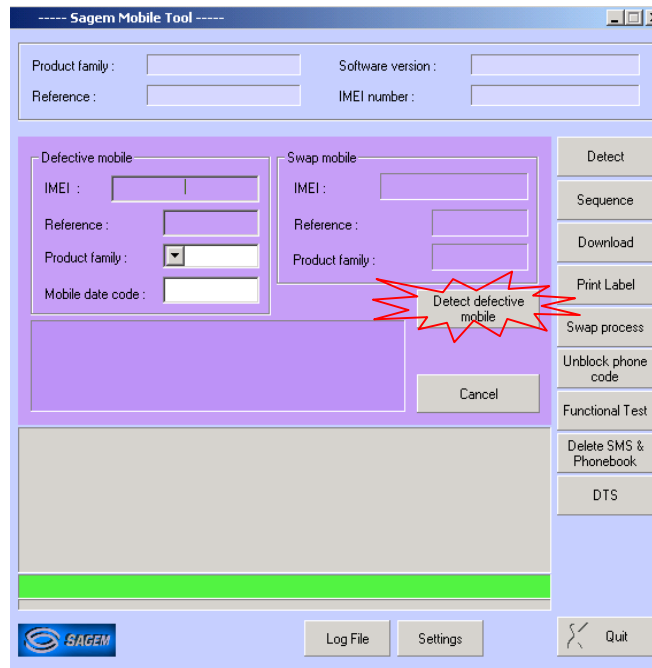

### Step 3a

**The following screen appears : the mobile is recognized. Then, enter the mobile date code**

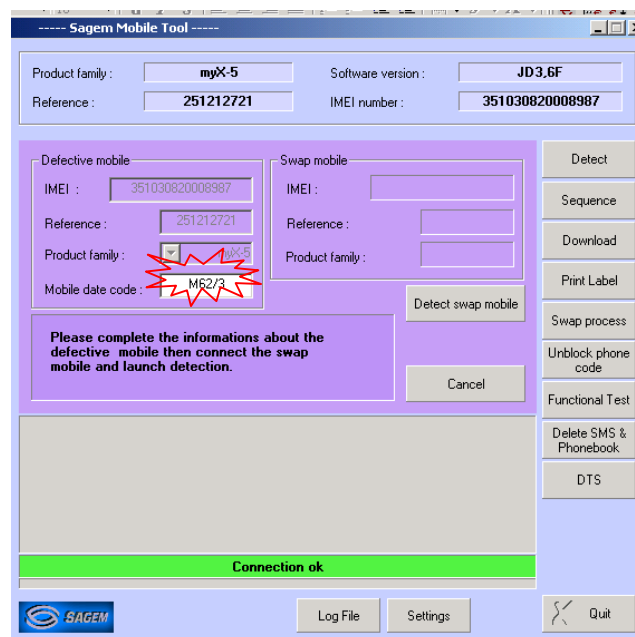

	<b>TEST AND CHECK BY SMT</b>	Test Sheet 01    6/9
myX-2		

### Step 3b

**If this screen appears, the mobile is not recognized.**

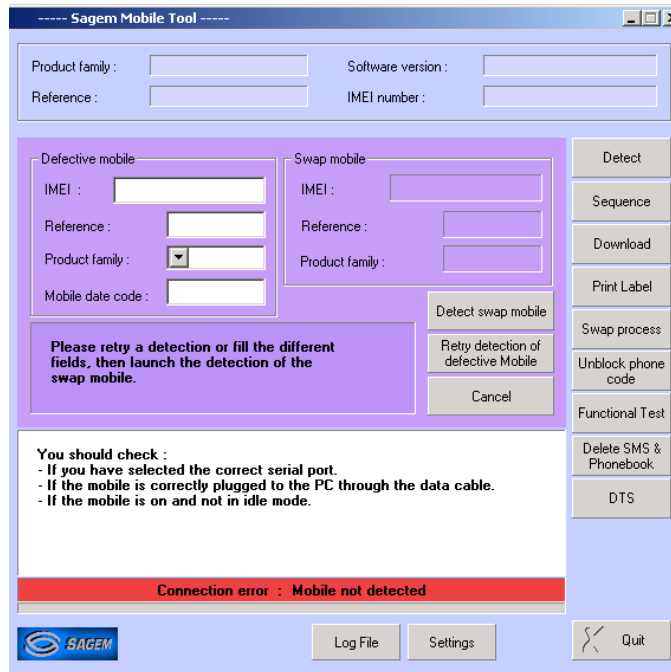

### Step 3c

**You must fill in the empty blanks requested according to the information written on the production label**

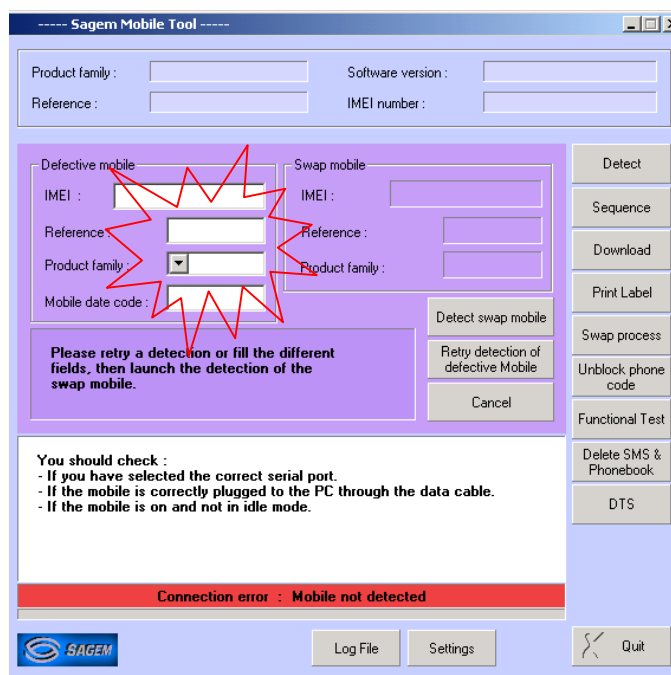

	<b>TEST AND CHECK BY SMT</b>	Test Sheet 01    7/9
myX-2		

### Step 4

**Plug and switch on the new mobile, then push on the “Detect Swap mobile” button**

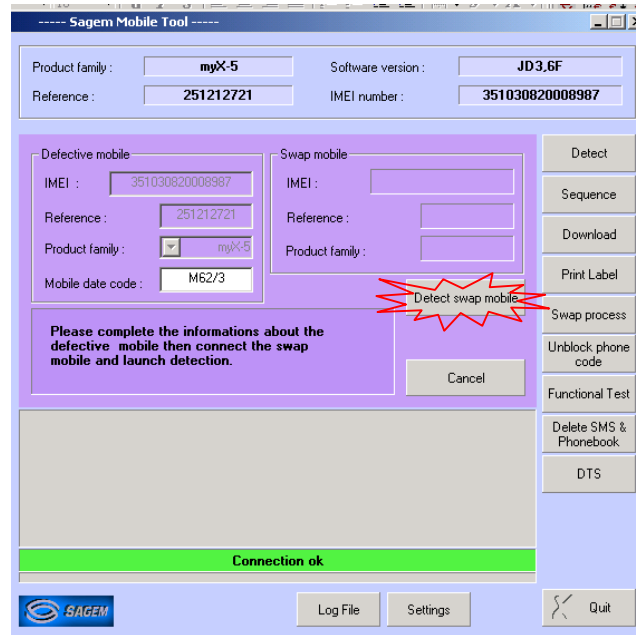

### Step 5

**After clicking on “OK”, SMT prints the label which will be used to close the ESD bag of the defective board.**

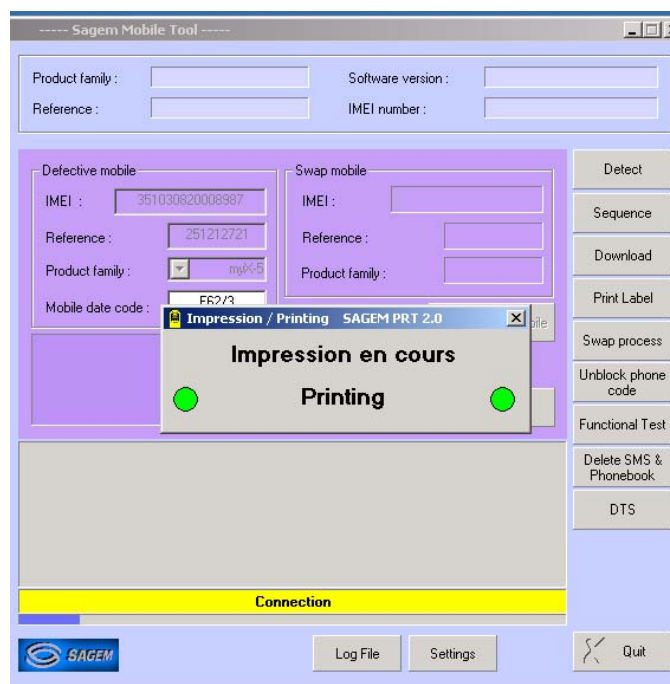

	<b>TEST AND CHECK BY SMT</b>	Test Sheet 01    8/9
myX-2		

### Step 6

**The downloading is starting if the mobile need to be updated**

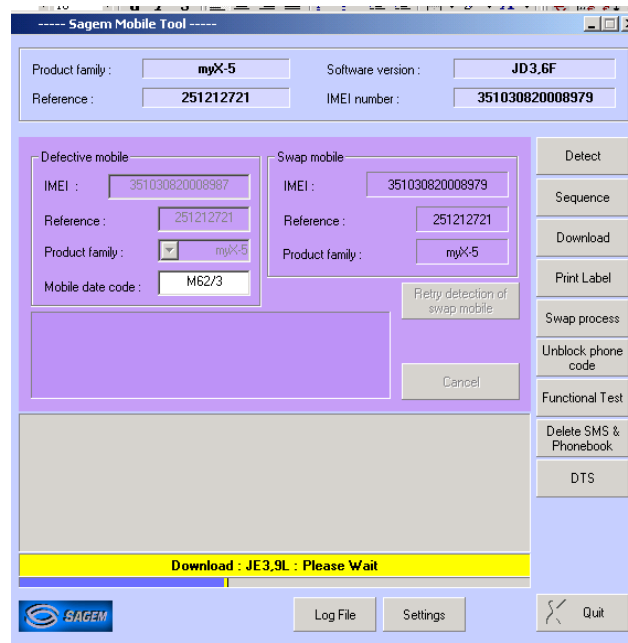

### Etape 7

**SMT opens the following screen to print the new label : please dial the “MAKING DATE” (Production date) written on the label of the defective mobile.**

**Then stick the new label on the functional mobile**

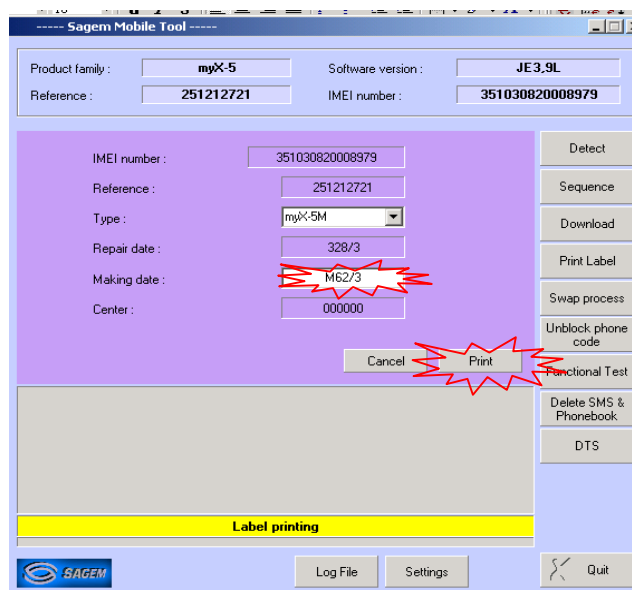

**The swap board sequence is completed.**

	<b>TEST AND CHECK BY SMT</b>	Test Sheet 01    9/9
myX-2		

## RESULTS

**When old mobile is recognized, the audio parameters from the defective mobile have been sent to the functional mobile.**

**When old mobile is not recognized, the DEFAULTS audio parameters are sent to the functional mobile**

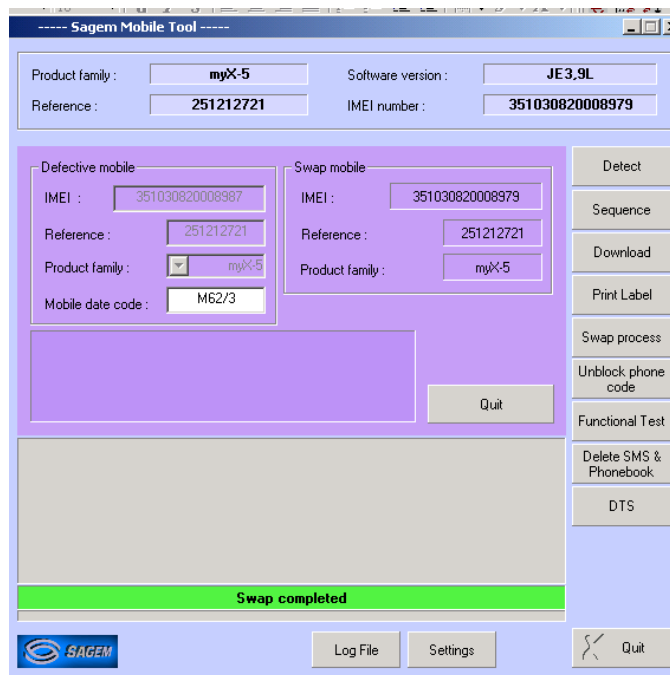



	<b>CHARGER TEST</b>	Test Sheet 02    1/1
myX-2		

***Test description***

This test checks the various battery chargers.

***Required tools***

- a voltmeter (minimum impedance 20 kΩ per Volt in DC),
- two sockets for banana connectors for connection to the voltmeter,
- a charger test kit.

***Test procedure***

Two terminals are used for measurements on the charger test kit

- red (+),
  - black (-).
  - A pushbutton selects the measurement :
    - at no load (released position),
    - under load (pushed in position).
1. Check visually the charger connector.
  2. Connect the charger to be tested to the back of the tester.
  3. Connect the voltmeter using the two banana connectors.
  4. Before starting any other measurement, check that the charger is correctly powered (mains voltage conform with the charger specifications).
  5. Make the two measurements.
  6. Check the recorded values using the following table.

Charger	At no load		Under load	
	Min.	Max.	Min.	Max.
Travel 500 mA	5,5 V	7,5 V	2 V	4 V
Simple 300 mA	9 V	15 V	1,5 V	4 V
cigar lighter	5,5 V	7,5 V	2 V	4 V

	<b>BATTERY TEST</b>	Test Sheet 03    1/1
myX-2		

***Test description***

This test allows to test the various batteries.

***Required tools***

- CADEX C7000 / C7200 / ASTRATEK
- myX-2 adapters,
- myX-2 Ammeter interface
- a voltmeter (minimum impedance 20 kΩ per Volt in DC).

***Test procedure***

7. Insert battery on ammeter interface
8. Measure the identification resistor between the Z poles :
9. Li-Ion batteries : **120kΩ (tolérance = 117kΩ - 123kΩ**, according to the surrounding temperature)
10. Measure the battery voltage between the V poles, **the voltage shown must be between 2.5V and 4.5V.**
  - If the voltage < 4v ,load the battery for 30 minutes with a travel charger and follow the instructions below
  - If the voltage > 4V Measure the internal resistance with a CADEX or ASTRATEK batteries testers
  - **Notice:** Choose on the batteries tester ,the battery type (Li-ion) ,the nominal battery voltage (3,6V) and the battery capacity (720 mA)
  - Read the result :If the internal resistance < 300 mOhms the battery is **OK**
  - If the internal resistance = 300 mOhms the battery is **defective**

	<b>CONSUMPTION TEST</b>	Test Sheet 04    1/1
myX-2		

***Test description***

This test tests the battery consumption.

***Required tools***

- myX-2 Ammeter interface
- An Ammeter.

***Test procedure***

*Measurement when switched off*

11. Insert the mobile (switched off) onto the tool (customer phone and battery).
12. Connect the ammeter to the tool between A poles:
  - Red tool terminal on the ammeter "**COM**" or "**GND**" terminal.
  - Black tool terminal on the ammeter "**+**" terminal.

NOTE: The ammeter rating must be set to DC (DC or =), range 100 mA.

13. The value shown must be less than 1 mA.
14. Disconnect the ammeter from the tool and remove the mobile from the tool, with the battery.

*Measuring the charge*

15. Insert the mobile (switched off) onto the tool (customer phone and battery).
16. Connect the ammeter to the tool between A poles:
  - Black tool terminal on the ammeter "**COM**" or "**GND**" terminal.

Connect the customer's charger when energised (after connecting the charger to the mains power supply).

17. The recorded value must be greater than 150 mA.

**NOTE: When changing the ammeter rating (manual or automatic), the mobile can be disconnected.**

	<b>"HOTLINE" MENU</b>	Test Sheet 05    1/1
myX-2		

### ***Access to the "HOTLINE" menu***

Access to the "HOTLINE" menu is possible with a powered up mobile.

The "HOTLINE" menu is accessed by pressing on the ▽ key and then the \* key.

Enter the corresponding code (bold) to choose the menu to be viewed.

To go out the "HOTLINE" menu, press successively on the **C** key to return at the operational screen of the mobile.

### ***Description of the myX-2 "HOTLINE" menu***

#### **1 APPLICATION**

- BATTERY : gives the value of the battery voltage.
- VERSION : reads the installed software version and the IMEI code.

#### **2 PROM : Not used**

#### **3 SIM LOCK : accesses the "SIM LOCK" menu (password required).**

#### **4 TESTS LCD**

- BLACK DISPLAY : displays the screen in black.
- WHITE DISPLAY.
- RED DISPLAY
- GREEN DISPLAY
- BLUE DISPLAY
- WHITE CHECKERBOARD
- PHOTO DISPLAY : functions on the screen to showing a picture.
- VIBRATE: tests the vibrating device.

**NOTE :** The "HOTLINE" menu is only accessible with a valid SIM card.

	<b>RADIO TESTS</b>	Test Sheet 06    1/1
myX-2		

**Test description**

This test tests myX-2 phones during a call.

**Required tools**

- a Wavetek
- a radio interface myX-2.
- an adjustable regulate power supply 0-15V / 4A

**Installation**

RF test

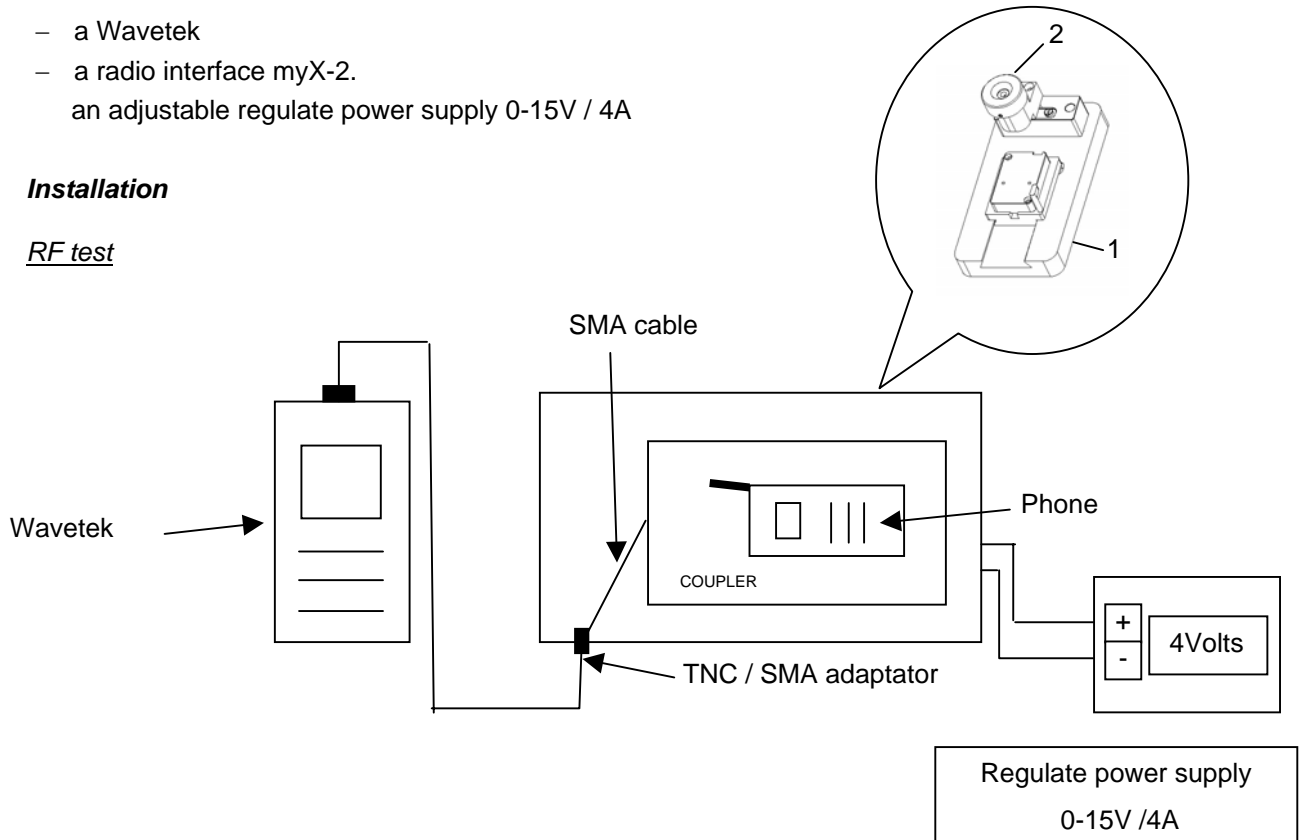

**Test procedure**

18. Position the myX-2 module on the radio interface (1) (provided with a SIM test card)
  19. Press and lock the button (2) , press the start key
  20. Switch the Wavetek on and press on "AUTOTEST".
  21. Choose the corresponding program using the "UP" et "DOWN" arrows.
    1. Mobile :**myX-2**
    2. Frequency range : **GSM, DCS or GSM/DCS,**
    3. Coupling type : **CABLE.**
  22. Press on "ENTER" and wait until the end of the calibration.
- Follow the instructions shown on the Wavetek.

## CHAPTER 5 - MAINTENANCE PROCEDURES

### 5.1 TECHNICAL WORK LEVELS

There are four technical work levels:

- Level 0,
- Level 1,
- Level 2,
- Level 3.

Each level represents a maintenance degree that depends on which elements are to be removed.

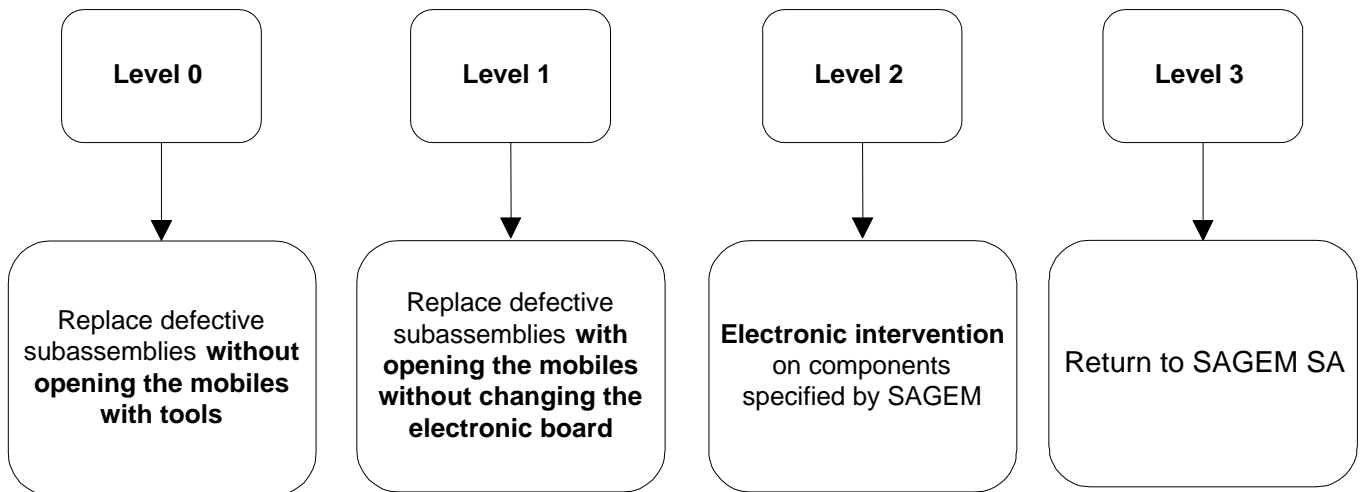

Maintenance procedure sheets are coded as follows :

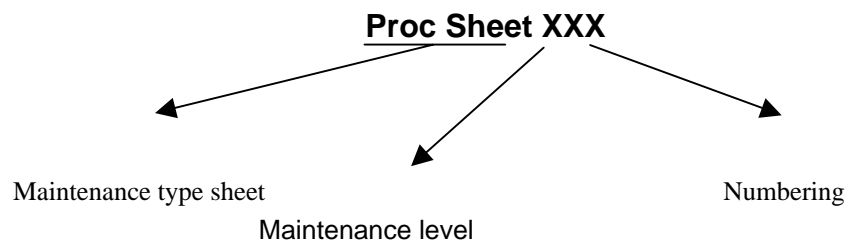

## 5.2 **SHORT LOOP PROCESS**

### 1. Initialisation

From the communication by Sagem and the reception of the concerned products by the short loop process, the Repair Centre shall comply with the above procedure. The application of the Short loop process will end when received the authorisation of repairing given by Sagem.

### 2. Administrative checks to be done by the Repair Centre

- Authorisation from Sagem for treating the reference received (Part number)
- Process to be applied : short loop process or normal process (DTS, Normal, etc...). The Repair Centre shall check if the product received has to be treated according to the short loop process.
- Controls on the warranty conditions and DOA conditions (if the Repair Centre is authorised) communicated by Sagem.

### 3. Tests and controls :

- Checks if there are no external shocks or oxidation marks ( the covers shall be dismantled in case of exchangeable covers)
- Checks and confirmation of the defect (real call with SIM, functional test keypad , display, vibrating device, etc...)
- Check the concordance between the defect declared by the end-user and the defect observed
- Call back of the end-user or dealer (as far as possible) either in case of misunderstanding of the defect declared by the end-user or in case of the non observation of the defect. (see the appendix "Additional information about the No Fault Found –NFF- " at the end of this document allowing according to the case to understand the return of the product)

If any doubts occurred concerning out of warranty products received, the Repair Centre shall send to Sagem Montauban (with knowledge to the Area Manager and Support Engineer) the photo of the defect.

### N.B :

- The handsets shall not be dismantled (by using screwdrivers) except previous request from Sagem.
- The Repair Centre will not make any Repair (such as spare parts exchange or software upgrade) except previous communication of Sagem. The exchanges of handsets or accessories are the only intervention authorised.

### 4. Exchange by the Repair Centre

- The Repair Centre will use the products delivered for swap to the Repair Centre for exchanging the products to the end-users (except particular process defined by Sagem).
- The under- warranty handsets and accessories received shall be exchanged to the end-user.
- The under- warranty handsets and accessories declared No Fault Found (NFF) shall be exchanged to the end-users except previous communication of Sagem.
- The Out of warranty handsets and accessories (oxidation, shocks, ...) will be repaired by the Repair Centre after acceptance by the customer of an estimate according to the Sagem out of warranty repair prices communicated.
- **The under- warranty and out of warranty handsets shall be sent to Sagem Montauban.**
- In the frame of the Short loop process, there is no level 1 (L1) intervention

### 5. Reports

An exchange of an handset and its accessories shall be codified Level 3 (L3)

An accessory exchange shall be codified Level 0 (L0).

The Repair Centre shall capture all the information required for issuing and sending the Repair Reports and Status reports according to the Contractual frequency defined. The Reports shall includes the products treated by the Repair Centre under- warranty or out of warranty.

## 6. Procedure

From the beginning date of the Short loop process application and **minimum each week, the Repair Centre shall ship the products (handsets and accessories) to Sagem Montauban.**

### 61. Handsets :

- MRA Procedure for the after-Sales products ( one MRA number for the products concerned by the short loop).
- MRA Procedure for DOA products ( one MRA DOA number for the products concerned by the short loop) if the Repair Centre is authorised to treat the DOA products.

The MRA request shall be sent to Sagem Montauban (with knowledge to the Area Manager and Support Engineer).

The shipment of products to Sagem Montauban shall comply with the MRA procedure. Furthermore each products shall be sent with the Return Product Sheet filled in indicating the defect declared by the end-user and the defect observed by the Repair Centre (Sagem Defect codes).

The NFF products sent to Sagem Montauban shall be identified by using separate package. Furthermore this products shall be sent with the complete description of the defect declared by the end-user ( not codified).

The accessories received by the Repair Centre shall be sent to Sagem Montauban sent back attached with the handset ( not connected to the handset).

### 62. Accessories :

For the accessories received without the handsets, the procedure is the following:

Accessories return procedure to Sagem Montauban to be used. The Repair Centre shall indicate on the parcel Accessories + model (ex : myX-2) for the accessories received in the Repair Centre without the handsets.

## 7. Sagem Montauban

Sagem Montauban will ship back to the Repair Centre the same quantity of handsets and accessories as the quantity received.



## 8 Additional information about the no fault found

In any case: Ask to the end-user the frequency of the defect and the circumstances of its apparition (during an incoming or out-going call, while playing, while downloading, etc.). Try to answer the questions: Where? When? How?

- If the customer complains about a **“Power supply / charging”** failure : (shutting down of the mobile, problem of booting, etc.);
  - During which operation ? In which circumstances ?
  - What is the state of the battery and the charger before shipment to the repair centre ?
  - If the mobile shuts down by itself, must he enter his code pin, adjust the date and the hour when rebooting the phone?
- If the customer complains about a communication problem:
  - What are his residence zone and the reception level of the mobile (Number of receipt bar);
  - What is the state of the battery when the defect appears?
  - In case of loss of communication :
    - With or without total extinction of the mobile?
    - Does the loss of communication occur always in the same place and with the same person?
    - Does the loss of communication occur while browsing in the menus, during the communication, or during playing or downloading?
- If the customer complains about a problem of blockage of key of the keyboard:
  - In which circumstances does the problem occur?
  - Did he activate the keypad locking ?
  - Did he change or remove the upper cover ?
  - Which are the non functioning keys ?

## 5.2 MAINTENANCE TOOLS

The following tools are necessary to carry out maintenance operations :

- Electrical screwdrivers with tightening torque settings **(0.25 NM)** ,equipped with 0,6 mm Torx .
- Metal dome jig.
- Plastic Tweezers.
- Gloves
- ESD protection strap

# **LEVEL 0 MAINTENANCE**

	<b>REMOVING / REPLACING BACK COVER</b>	Proc Sheet 0 01
myX-2		1/2

**Tools :**

Not applicable.

**Preliminary operation**

Turn the handset upside down

**Removal procedure :**

- 1 Unlock the back cover (1) , by pushing the lock buttons (2) inside the mobile.
- 2 Remove rear cover (1) by lifting bottom end first

**Placement procedure :**

1. Replace the cover by engaging top hooks first .
2. Push down back of rear cover and push button back into locked position

**Further operations :**

1. Check the covers are assembled tightly

 <b>SAGEM</b>	<b>REMOVING / REPLACING THE BACK COVER</b>	Proc sheet 0 01
myX-2		2/2

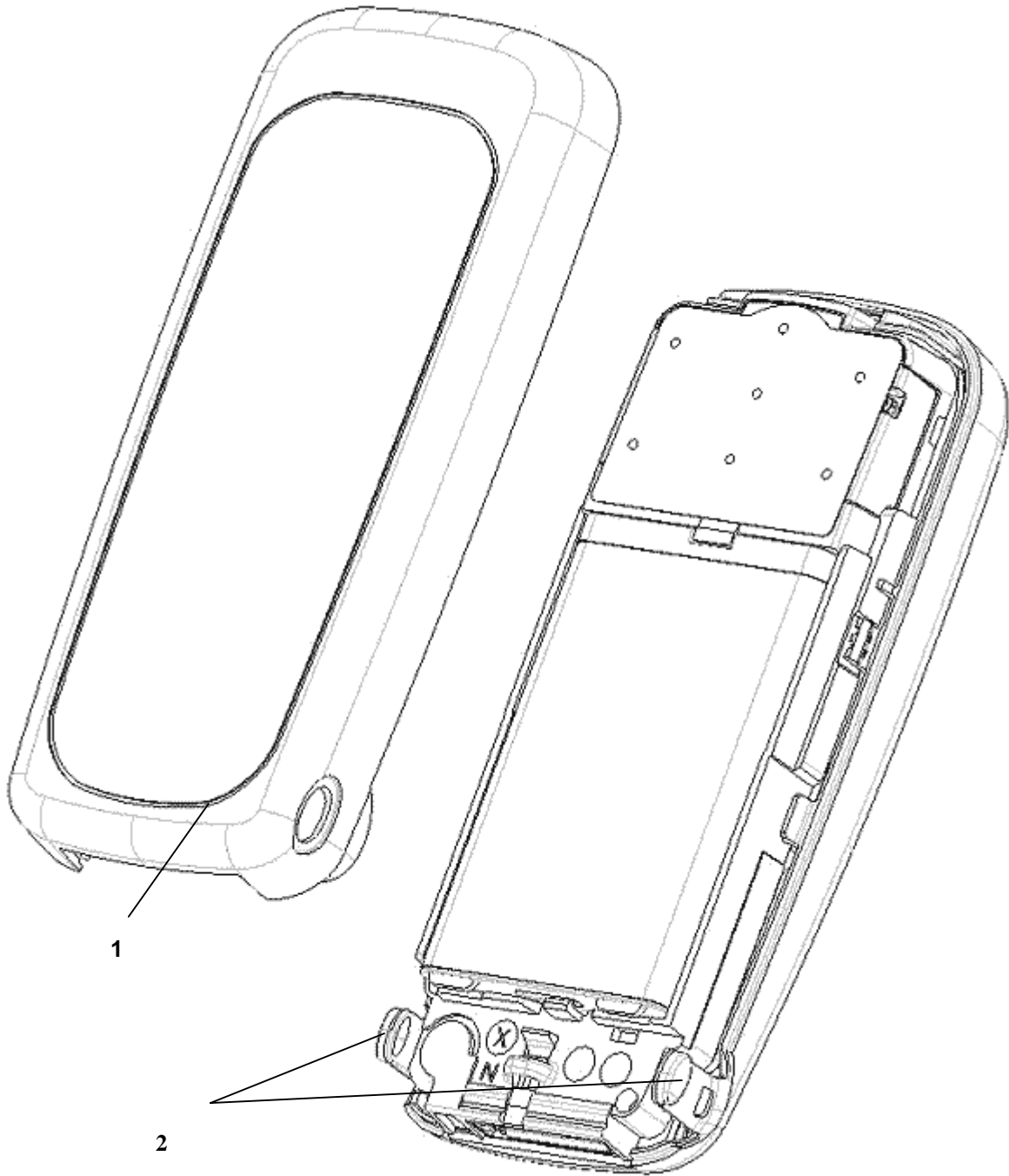

	<b>REMOVING / REPLACING THE BATTERY</b>	Proc Sheet 0 02
myX-2		1/2

**Tools :**

- Not applicable

**Preliminary operation :**

- Switch off the mobile phone

**Removal procedure :**

1. Remove the back cover ( [Proc sheet 0 01](#)).
2. Take out the battery (1) by first extracting the stop pins (2).

**Placement procedure :**

1. Place the battery by first inserting the upper section.
2. Place the back cover ([Proc sheet 0 01](#)).

	<b>REMOVING / REPLACING THE BATTERY</b>	Proc Sheet 0 02
myX-2		2/2

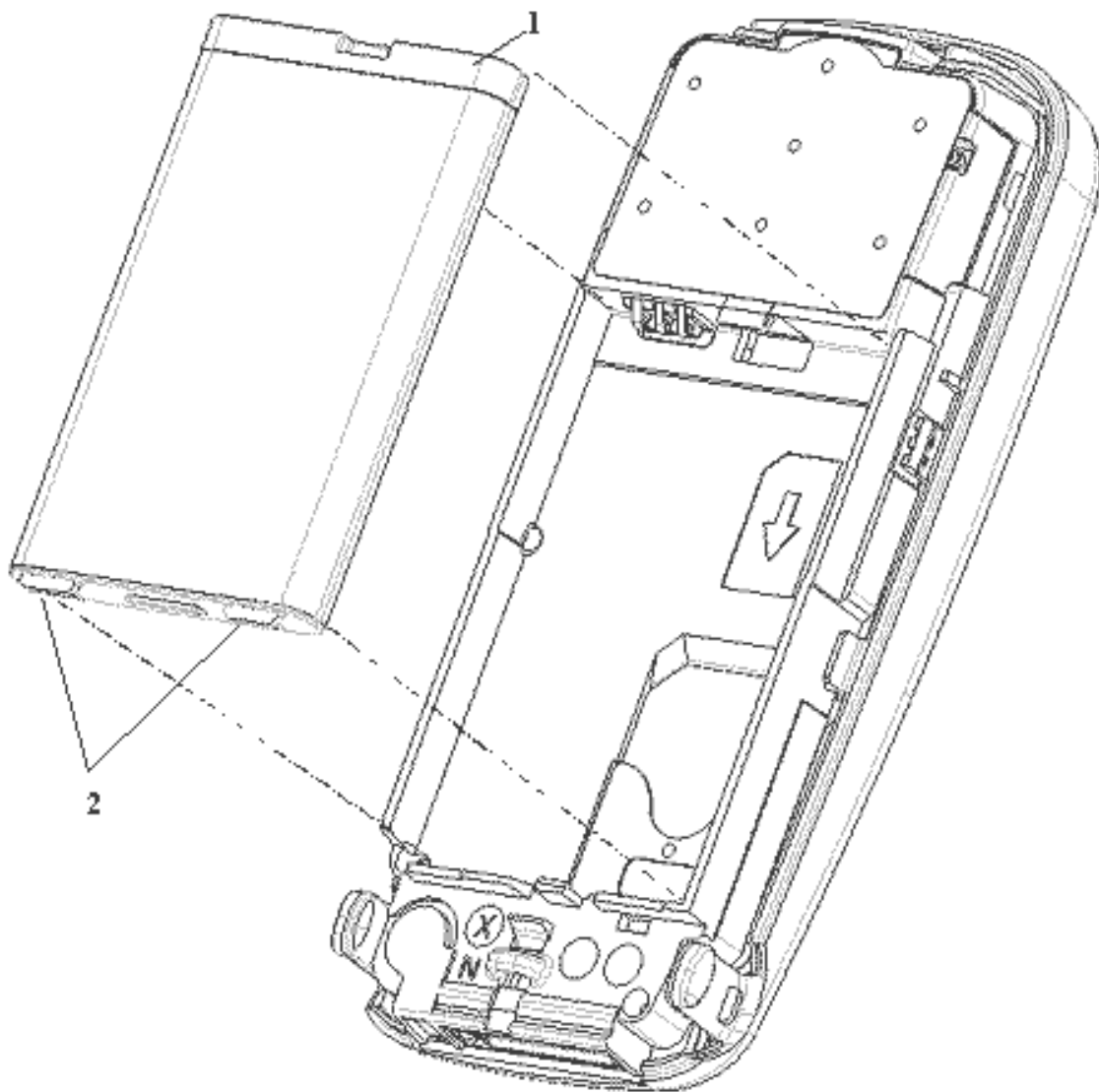

	<b>REMOVING / REPLACING THE FRONT COVER</b>	Proc Sheet 0 03
myX-2		1/2

**Tools :**

- Not applicable

**Preliminary operation :**

1. Remove the back cover ( [Proc sheet 0 01](#)).

**Removal procedure :**

1. Separate the two front cover (2) fixing stop pins (3) to release the electronic module (1).
2. Remove the equipped front cover (2).
3. Remove the elastomer keypad (4).

**Placement procedure :**

1. On the new front cover (2), position the elastomer keypad (4) in position, ensuring it is free of dust.
2. Place the module (1) onto front cover (2) ,engaging firstly the module top, then press on the module top (1)

**Further operations**

1. Place the back cover ([Proc sheet 0 01](#)).

	<b>REMOVING / REPLACING THE FRONT COVER</b>	Proc sheet 0 03
myX-2		2/2

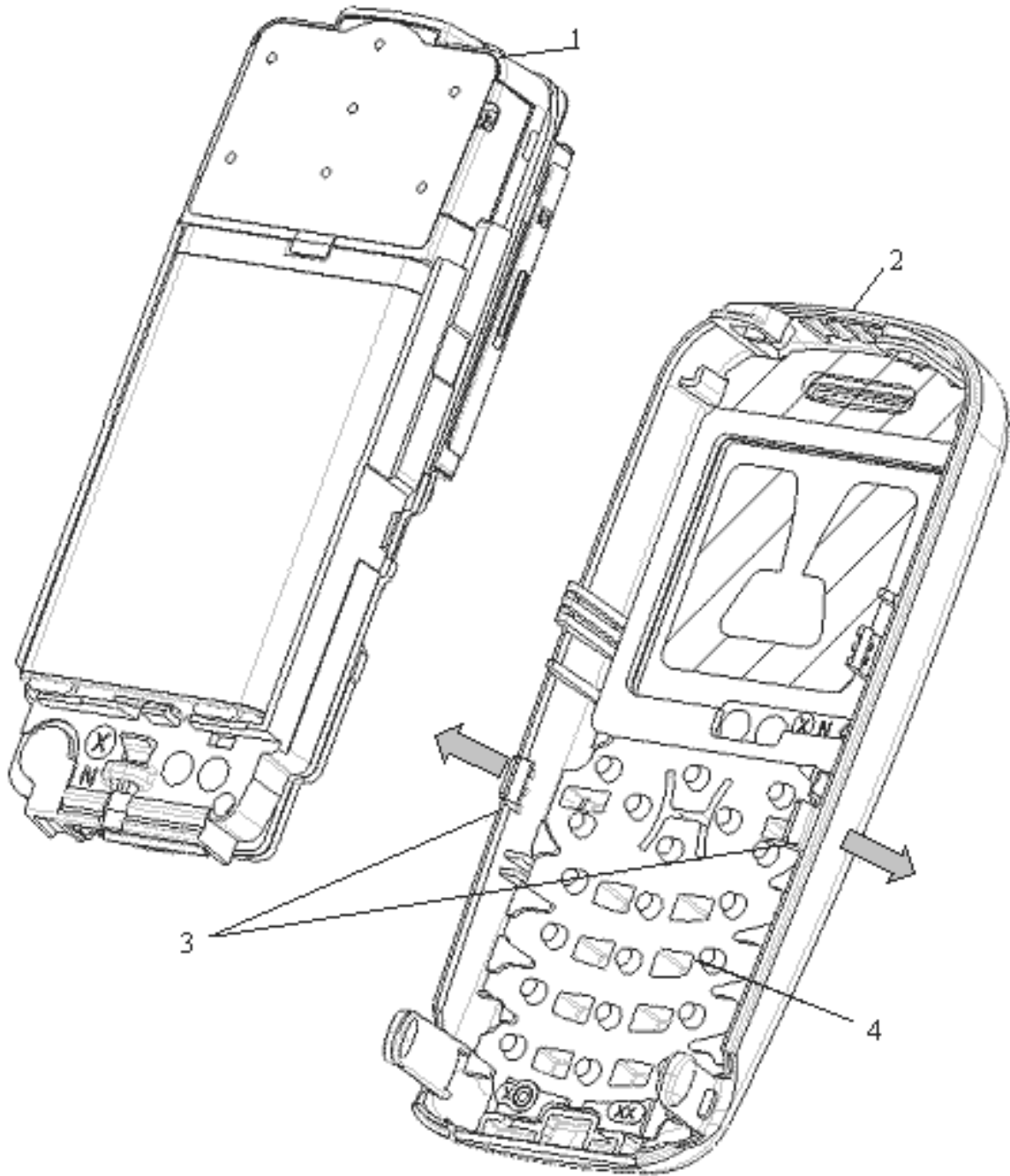



	<b>REMOVING / REPLACING THE ELASTOMER KEYPAD</b>	Proc Sheet 0 04
myX-2		1/2

**Tools :**

- Not applicable

**Preliminary operation**

1. Remove the back cover ( [Proc sheet 0 01](#)).
2. Remove the front cover ( [Proc sheet 0 03](#)).

**Removal procedure :**

1. Remove the elastomer keypad (2) from the front cover (1).

**Placement procedure :**

1. Clean the elastomer keypad (2) with compressed air.
2. Place the elastomer keypad (2) in position in its housing

**Further operations :**

1. Replace the front cover ([Proc sheet 0 03](#)).
2. Replace the back cover ([Proc sheet 0 01](#)).

	<b>REMOVING / REPLACING THE ELASTOMER KEYPAD</b>	Proc Sheet 0 04
myX-2		2/2

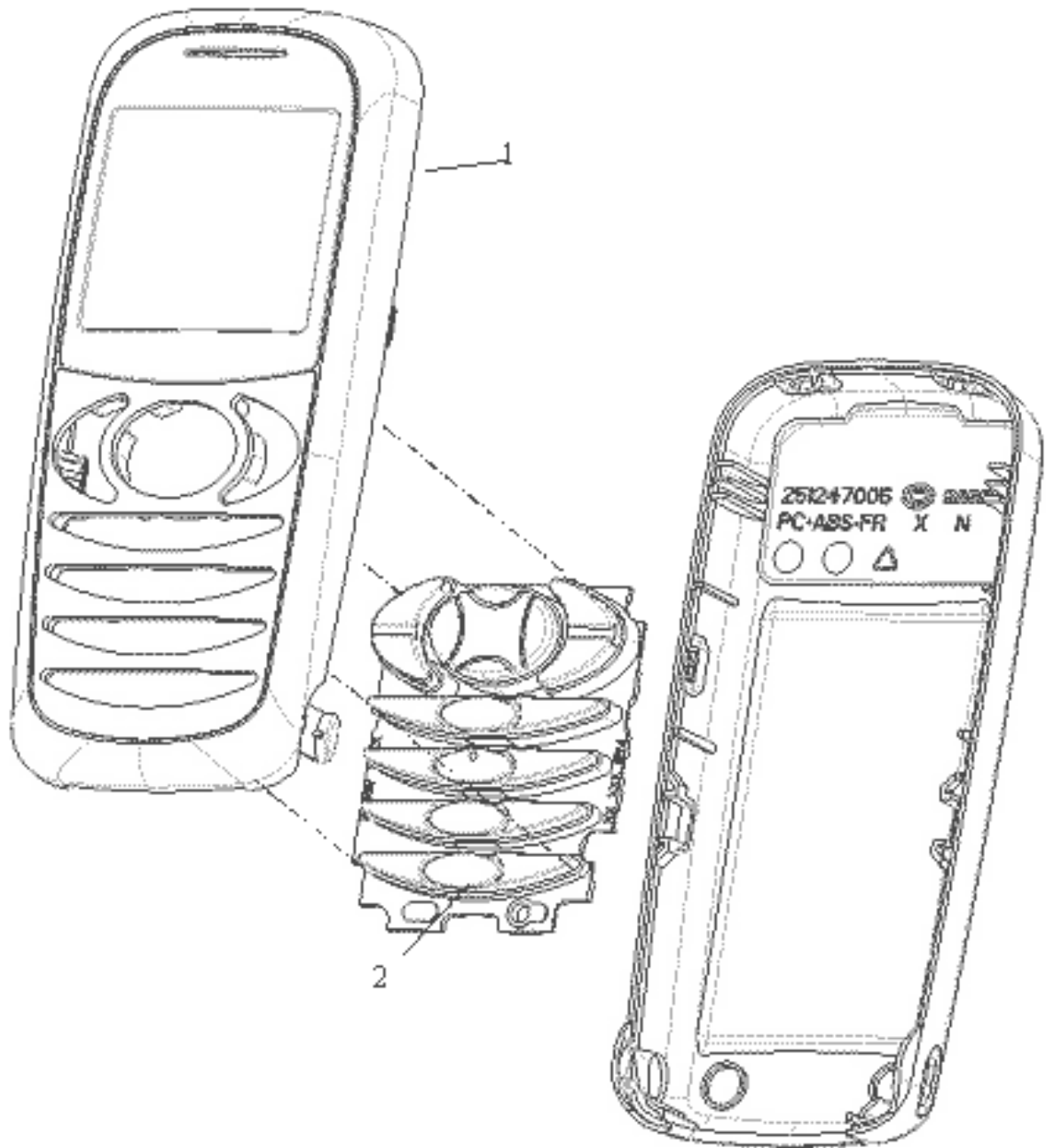

# LEVEL 1 MAINTENANCE

	<b>REMOVING / REPLACING THE DISPLAY</b>	Proc Sheet 1 02
myX-2		1/2

**Tools :**

- A 0.6mm torx screwdriver
- gloves

- **This procedure must be performed by a technician provided with gloves , to avoid any risk of pollution.**
- **Contacts of display must be never touched.**

**Preliminary operation**

1. Remove the back cover ( [Proc sheet 0 01](#)).
2. Remove the battery ( [Proc sheet 0 02](#)).
3. Remove the front cover ( [Proc sheet 0 03](#)).

**Removal procedure :**

1. On the electronic equipped module , unscrew the four attachment screws (4) .
2. Remove the assembly display (2) (3).
1. Remove the display ( 3 ), of the support ( 2 ) by pushing it in its centre .

**Placement procedure :**

1. Replace the display (3) of the support (2),beginning with the bottom.
2. Replace the assembly display (2) (3) on the electronic equipped module (1).
3. Position and tighten the four attachments screws with **0,25 N.m** torque.
4. Verify that there are no impurities on the display.

**Further operations :**

1. Replace the front cover ([Proc sheet 0 03](#)).
2. Replace the battery ([Proc sheet 0 02](#)).
3. Replace the back cover ([Proc sheet 0 01](#)).
4. Carry out the radio test ([Test Sheet 06](#)).

	<b>REMOVING / REPLACING THE DISPLAY</b>	Proc Sheet 1 02
myX-2		2/2

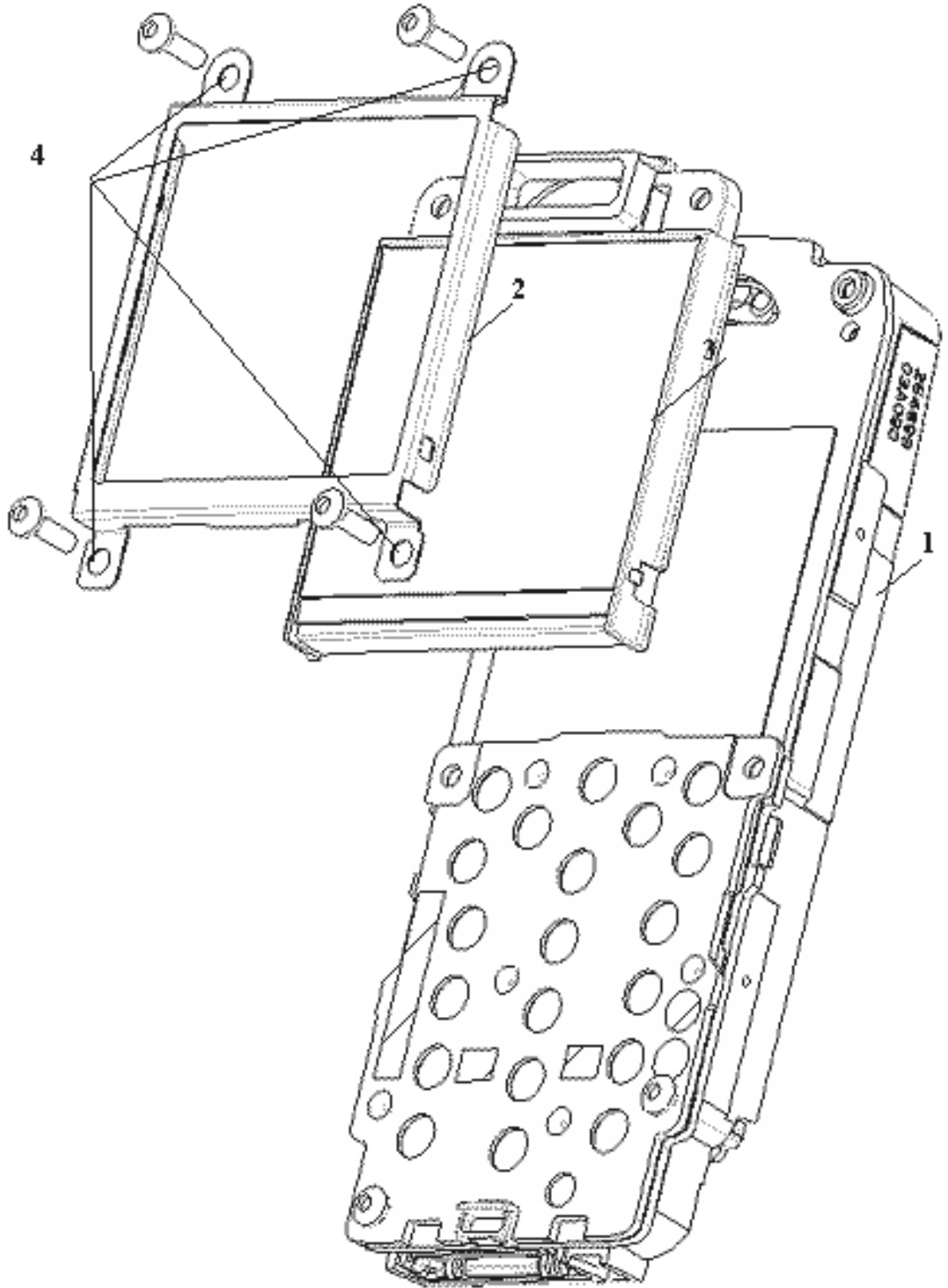

	<b>REMOVING / REPLACING THE LIGHT GUIDE KEYPAD</b>	Proc Sheet 1 03
myX-2		1/2

**Tools :**

- A 0.6mm torx screwdriver

**Preliminary operation**

1. Remove the back cover ( [Proc sheet 0 01](#)).
2. Remove the battery ( [Proc sheet 0 02](#)).
3. Remove the front cover ( [Proc sheet 0 03](#)).

**Removal procedure :**

1. Unscrew the six attachment screws on the assembly plate (1)
2. Remove the assembly display ([Proc sheet 1.02](#))
3. Remove the light guide keypad (2).

**Placement procedure :**

1. Replace the new light guide keypad on its housing.
2. Replace the assembly display ([Proc sheet 1.02](#))
3. Position and tighten the six attachments screws with **0,25 N.m** torque.

**Further operations :**

1. Replace the front cover ([Proc sheet 0 03](#)).
2. Replace the battery ([Proc sheet 0 02](#)).
3. Replace the back cover ([Proc sheet 0 01](#)).
4. Carry out radio test ([Test Sheet 06](#)).

	<b>REMOVING / REPLACING THE LIGHT GUIDE KEYPAD</b>	Proc Sheet 1 03
myX-2		2/2

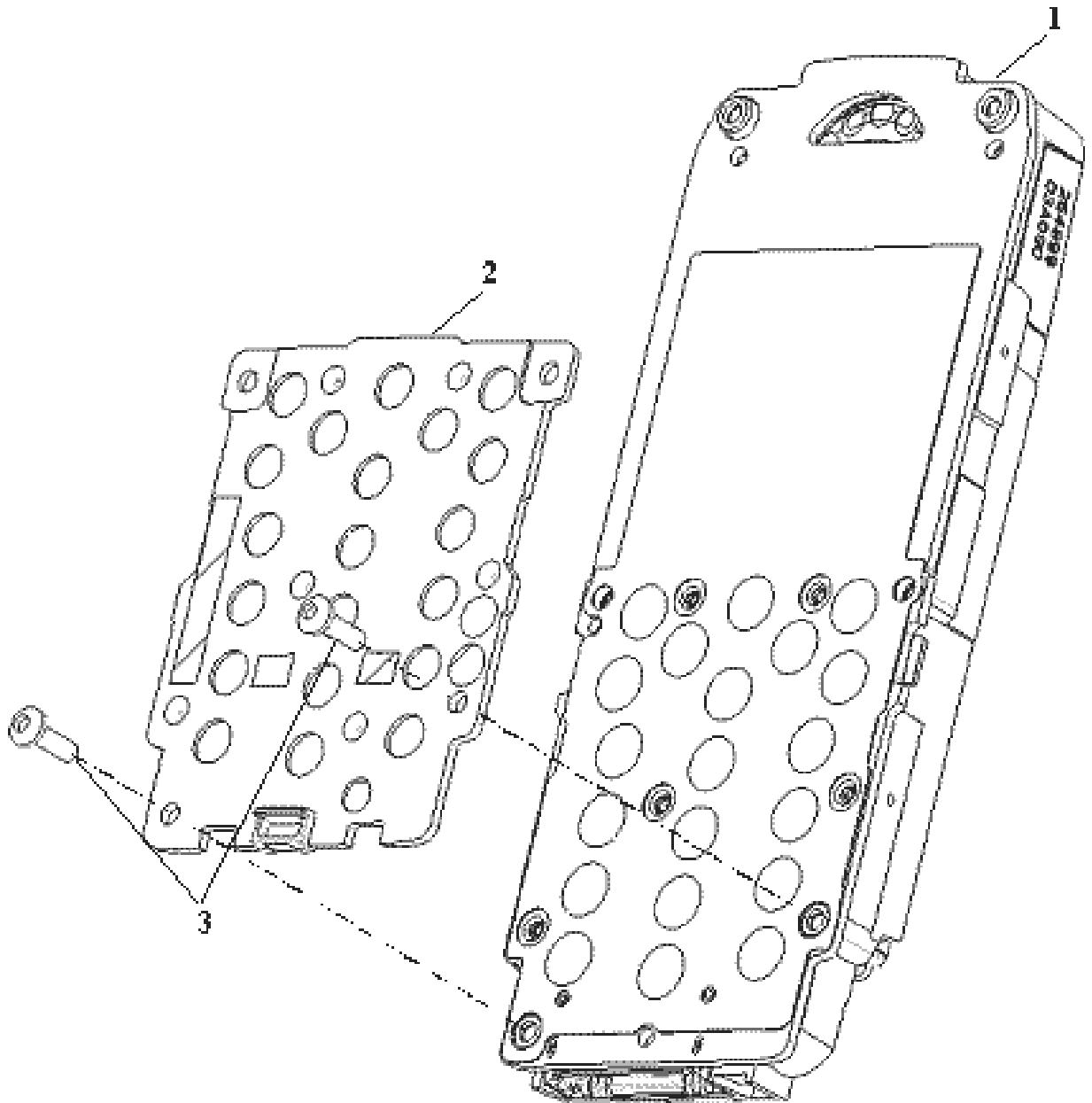

	<b>REMOVING / REPLACING THE ELECTRONIC BOARD</b>	Proc Sheet 1 04
myX-2		1/2

**Tools :**

- A 0.6mm torx screwdriver

**Preliminary operation**

1. Remove the back cover ( [Proc sheet 0 01](#)).
2. Remove the battery ( [Proc sheet 0 02](#)).
3. Remove the front cover ( [Proc sheet 0 03](#)).

**Removal procedure :**

1. Unscrew the six attachment screws on the assembly plate (2)
2. Remove the assembly display ([Proc sheet 1 02](#))
3. Remove the light guide keypad ([Proc sheet 1 03](#))
4. Remove the electronic board (1) on the assembly plate (2).([Proc sheet 1 10](#))

**Placement procedure :**

1. Replace the new electronic board on the assembly plate (2).([Proc sheet 1 10](#))
2. Replace the light guide keypad on its housing.
3. Replace the assembly display ([Proc sheet 1.02](#))
4. Position and tighten the six attachments screws with **0,25 N.m** torque.

**Further operations :**

1. Replace the front cover ([Proc sheet 0 03](#)).
2. Replace the battery ([Proc sheet 0 02](#)).
3. Replace the back cover ([Proc sheet 0 01](#)).
4. Carry out the radio test ([Test Sheet 06](#)).



	<b>REMOVING / REPLACING THE ELECTRONIC BOARD</b>	Proc Sheet 1 04
myX-2		2/2

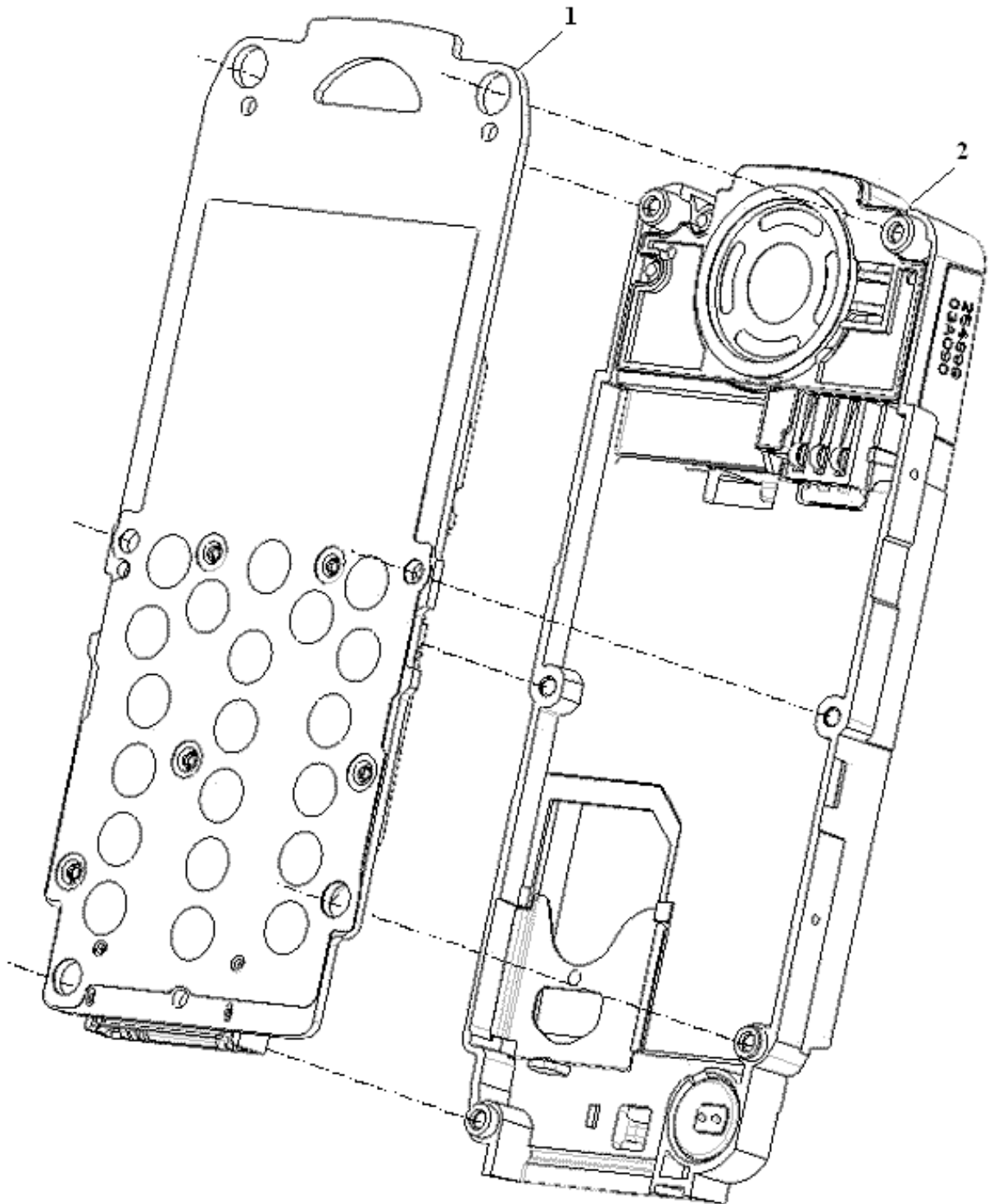

	<b>REMOVING / REPLACING THE METAL DOME</b>	Proc Sheet 1 05
myX-2		1/2

**Tools :**

- A 0.6mm torx screwdriver
- Gloves
- Metal dome Jig
- Tweezers

**Preliminary operation**

**This procedure must be performed by a technician with gloves.**

1. Remove the back cover ( [Proc sheet 0 01](#)).
2. Remove the battery ( [Proc sheet 0 02](#)).
3. Remove the front cover ( [Proc sheet 0 03](#)).
4. Unscrew the six attachment screws on the electronic board (1)
5. Remove the assembly display ([Proc sheet 1 02](#) ),then the light guide keypad ([Proc sheet 1 03](#))

**Removal procedure :**

1. Lift up the metal dome (2) on the electronic card (1) with tweezers.

**Placement procedure :**

**Warning : The metal dome is not reusable, it must be necessarily replaced by a new metal dome, unless the board is swapped and sent as level 3**

1. Replace the metal dome on the electronic card, using the metal dome jig.

**Further operations :**

1. Replace the new electronic board on the assembly plate (2).([Proc sheet 1.04](#))
2. Replace the light guide keypad ([Proc sheet 1.03](#))
3. Replace the assembly display ([Proc sheet 1.02](#))
4. Position and tighten the six attachments screws with torque settings of **0,25 N.m.**
5. Replace the front cover ([Proc sheet 0 03](#)).
6. Replace the battery ([Proc sheet 0 02](#)).
7. Replace the back cover ([Proc sheet 0 01](#)).
8. Carry out the radio test ([Test Sheet 06](#)).

 <b>SAGEM</b>	<b>REMOVING / REPLACING THE METAL DOME</b>	Proc Sheet 1 05
myX-2		2/2

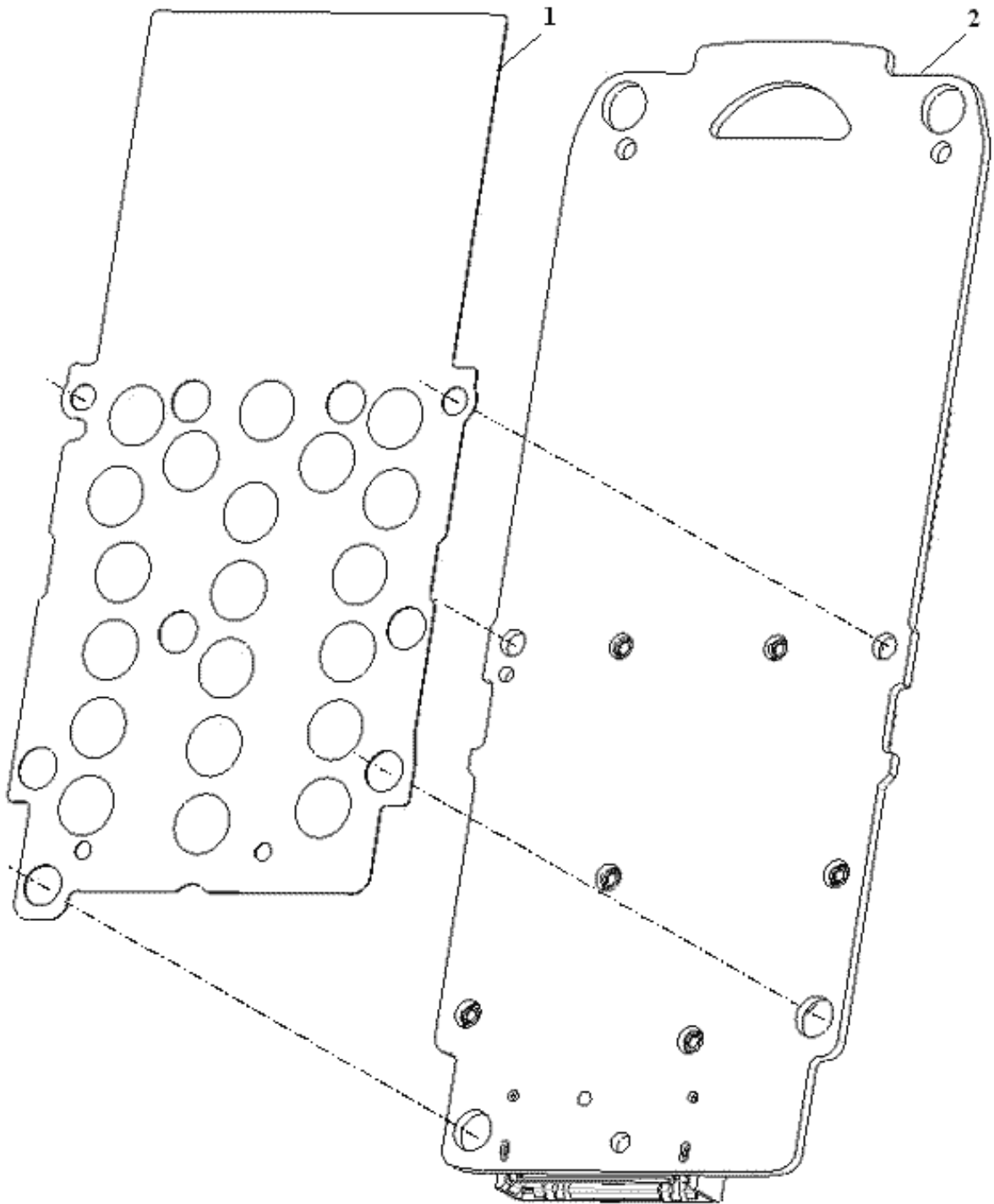

	<b>REMOVING / REPLACING THE SIM LOCKER</b>	Proc Sheet 1 06
myX-2		1/2

**Tools :**

- A 0.6mm torx screwdriver

**Preliminary operation :**

1. Remove the back cover ( [Proc sheet 0 01](#)).
2. Remove the battery ( [Proc sheet 0 02](#)).
3. Remove the SIM card .
4. Remove the front cover ( [Proc sheet 0 03](#)).
5. Unscrew the six attachment screws on the electronic board .
6. Remove the assembly display ([Proc sheet 1 02](#))
7. Remove the light guide keypad ([Proc sheet 1 03](#))
8. Remove the electronic board.([Proc sheet 1 04](#))

**Removal procedure :**

1. On the assembly plate (2), looked at from the battery side ,press firmly the SIM locker (1) until its extraction .
2. Remove the SIM cover (1).

**Placement procedure :**

1. Place the SIM cover (1) in position in its housing.
2. Click fit the SIM cover (1) on the plate.

**Further operations :**

1. Remove the electronic board on the assembly plate.([Proc sheet 1 04](#))
2. Replace the light guide keypad ([Proc sheet 1.03](#))
3. Replace the assembly display ([Proc sheet 1 02](#))
4. Position and tighten the six attachments screws with **0,25 N.m** torque.
5. Replace the front cover /battery / back cover ([Proc sheet 0 01 / 0 02 / 0 03](#)).
6. Carry out the radio test ([Test Sheet 06](#)).

	<b>REMOVING / REPLACING THE SIM LOCKER</b>	Proc Sheet 1 06
myX-2		2/2

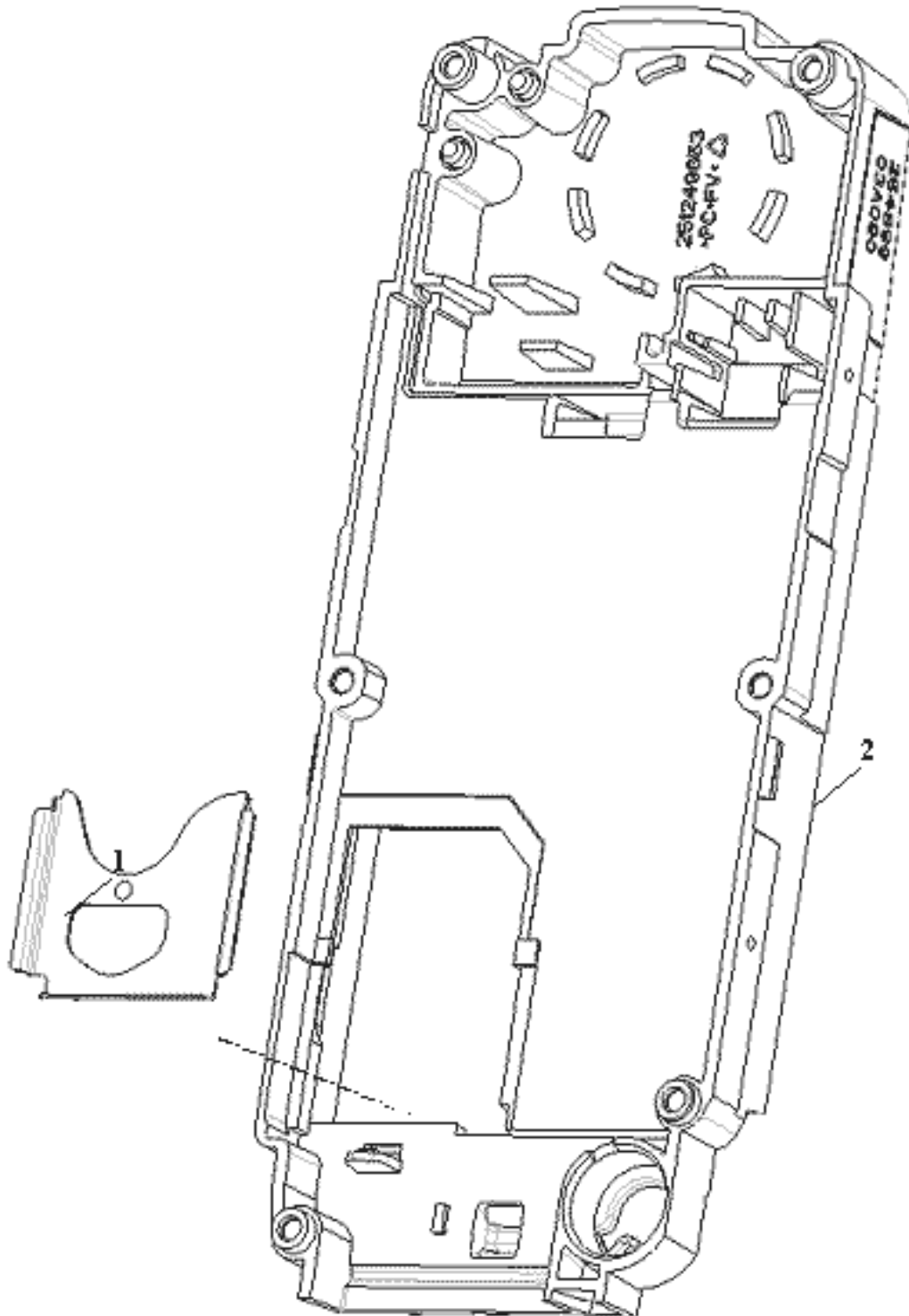

	<b>REMOVING / REPLACING THE BATTERY CONNECTOR</b>	Proc Sheet 1 07
myX-2		1/2

**Tools :**

- A 0.6mm torx screwdriver
- Tweezers

**Preliminary operation**

1. Remove the back cover ( [Proc sheet 0 01](#)).
2. Remove the battery ( [Proc sheet 0 02](#)).
3. Remove the front cover ( [Proc sheet 0 03](#)).
4. Unscrew the six attachment screws on the electronic board.
5. Remove the assembly display , then the light guide keypad ( [Proc sheet 1 02 / 1 03](#) )
6. Remove the electronic board.([Proc sheet 1 04](#))

**Removal procedure :**

1. Remove the battery connector (1) , using tweezers

**Placement procedure :**

1. Place the battery connector (1) in position in its housing, respecting the foolproof device.

**Further operations :**

1. Remove the electronic board on the assembly plate.([Proc sheet 1 04](#))
2. Replace the light guide keypad ([Proc sheet 1.03](#))
3. Replace the assembly display ([Proc sheet 1 02](#))
4. Position and tighten the six attachments screws with torque settings of **0,25 N.m.**
5. Replace the front cover /battery / back cover ([Proc sheet 0 01 / 0 02 / 0 03](#)).
6. . Carry out the radio test ([Test Sheet 06](#)).

	<b>REMOVING / REPLACING THE BATTERY CONNECTOR</b>	Proc Sheet 1 07
myX-2		2/2

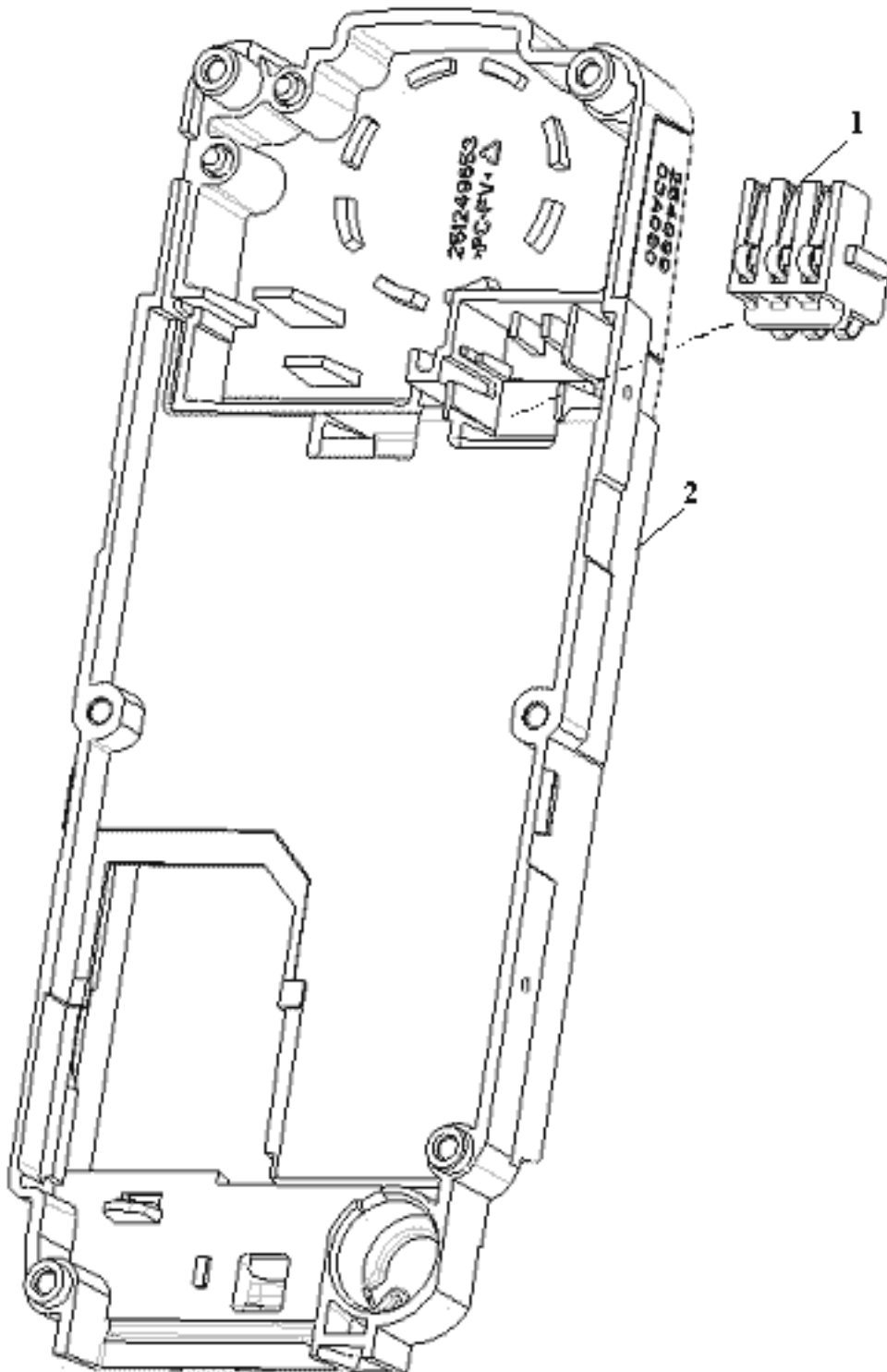

	<b>REMOVING / REPLACING THE MICROPHONE</b>	Proc Sheet 1 08
myX-2		1/2

**Tools :**

- A 0.6mm torx screwdriver
- Tweezers

**Preliminary operation**

1. Remove the back cover ( [Proc sheet 0 01](#)).
2. Remove the battery ( [Proc sheet 0 02](#)).
3. Remove the front cover ( [Proc sheet 0 03](#)).
4. Unscrew the six attachment screws on the electronic board.
5. Remove the assembly display , then the light guide keypad ([Proc sheet 1 02 / 1 03](#))
6. Remove the electronic board.([Proc sheet 1 04](#))

**Removal procedure:**

1. Remove the microphone (1) , using tweezers.

**Placement procedure :**

1. Put the microphone (1) in position in its housing (2).

**Further operations :**

1. Remove the electronic board on the assembly plate. .([Proc sheet 1 04](#))
2. Replace the light guide keypad ([Proc sheet 1.03](#))
3. Replace the assembly display ([Proc sheet 1 02](#))
4. Position and tighten the six attachments screws with **0,25 N.m** torque.
5. Replace the front cover /battery / back cover ([Proc sheet 0 01 / 0 02 / 0 03](#)).
6. Carry out the radio test ([Test Sheet 06](#)).



	<b>REMOVING / REPLACING THE MICROPHONE</b>	Fiche Proc 1 08
myX-2		2/2

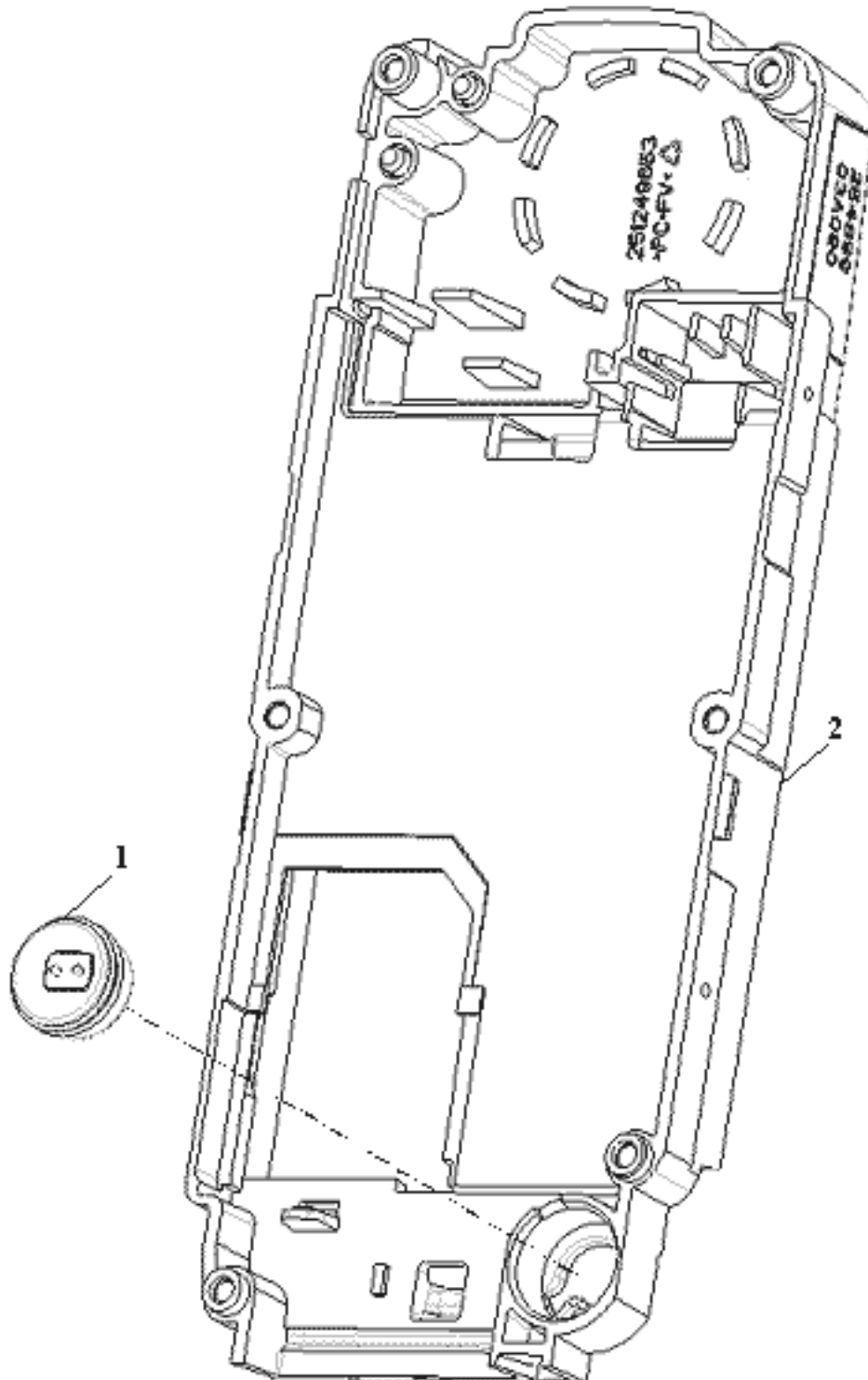

	<b>REMOVING / REPLACING THE LOUDSPEAKER/ VIBRATING DEVICE</b>	Proc Sheet 1 09
myX-2		1/2

**Tools :**

- A 0.6mm torx screwdriver
- Tweezers

**Preliminary operation**

1. Remove the back cover ( [Proc sheet 0 01](#)).
2. Remove the battery ( [Proc sheet 0 02](#)).
3. Remove the front cover ( [Proc sheet 0 03](#)).
4. Unscrew the six attachment screws on the electronic board.
5. Remove the assembly display , then the light guide keypad ([Proc sheet 1 02 / 1 03](#))
6. Remove the electronic board.([Proc sheet 1 04](#))

**Removal procedure :**

**Notice: do not touch the loudspeaker diaphragm**

1. Remove, with the tweezers, the equipped loudspeaker/ vibrating device (1) in its housing (2).

**Placement procedure :**

1. Put the loudspeaker/ vibrating device in its housing, respecting the foolproof device

**Further operations :**

1. Remove the electronic board on the assembly plate. .([Proc sheet 1 04](#))
2. Replace the light guide keypad ([Proc sheet 1.03](#))
3. Replace the assembly display ([Proc sheet 1 02](#))
4. Position and tighten the six attachments screws with **0,25 N.m** torque.
5. Replace the front cover /battery / back cover ([Proc sheet 0 01 / 0 02 / 0 03](#)).
6. Carry out the radio test ([Test Sheet 06](#)).

	<b>REMOVING / REPLACING THE LOUDSPEAKER/ VIBRATING DEVICE</b>	Proc Sheet 1 09
myX-2		2/2

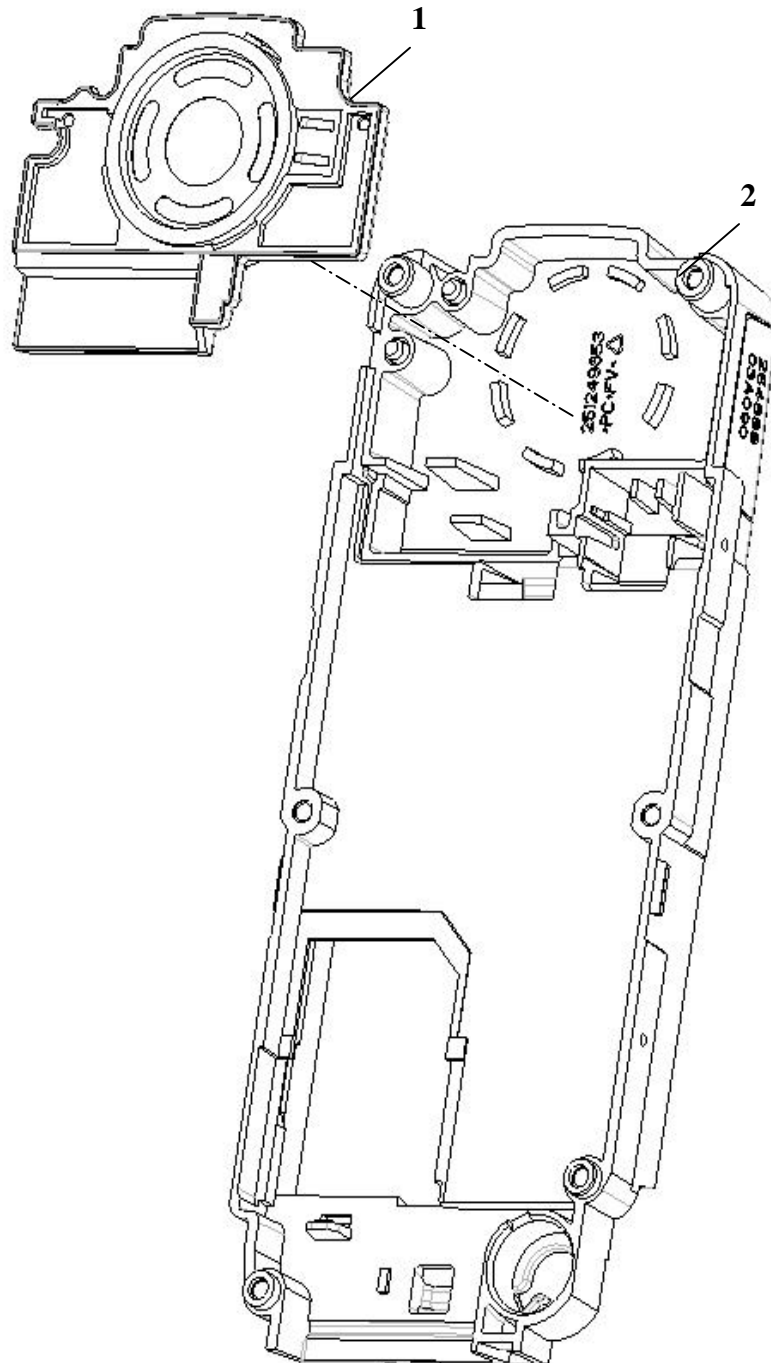

	<b>ELECTRONIC BOARD EXCHANGE</b>	Proc Sheet 1 10
myX-2		1/3

***Preliminary operation***

1. Control of the IMEI label integrity
2. Remove the electronic board (Proc sheet 1 04)
3. Control of any oxidation marks (on the electronic board and under the metal dome)

***Return procedure :***

- (a) The electronic boards are packaged in individual electrostatic envelopes. They must be stocked in their original package of reception , to insure a good protection against external attacks (see enclosed photos)
- (b) During the electronic boards manipulation , gloves and electrostatic strap must be worn at all times.
- (c) The defective electronic boards have to be returned to SAGEM factory, packaged individually, in the original package (see enclosed photos) , in the appropriate ESD box : One box per Sagem reference (check reference written on the box).
- (d) The defective board should display the defect code written on a sticker (placed on the shielding) and have the label provided with SMT on each ESD bag .

**Note :**

- **On the defective boards , it is necessary to check visually under the metal dome to discover if it shows oxidation marks. The defective boards should be returned with their original metal dome**
- **Boards with oxidation should not to set in conformance with the warranty**
- **The defective boards must never be mixed with the complete mobiles**

***Placement procedure :***

1. Take a board in the stock of swap boards from the same Sagem reference.

***Further operations :***

1. Place the new electronic board on the assembly plate. [.\(Proc sheet 1 04\)](#)
2. Replace the customer housing (Proc Sheet 0 03 et 1 01)
3. Follow stages ( see enclosed photos)

	<b>ELECTRONIC BOARD EXCHANGE</b>	Proc sheet 1 10
myX-2		2/3

*Example of electronic boards packaging :*

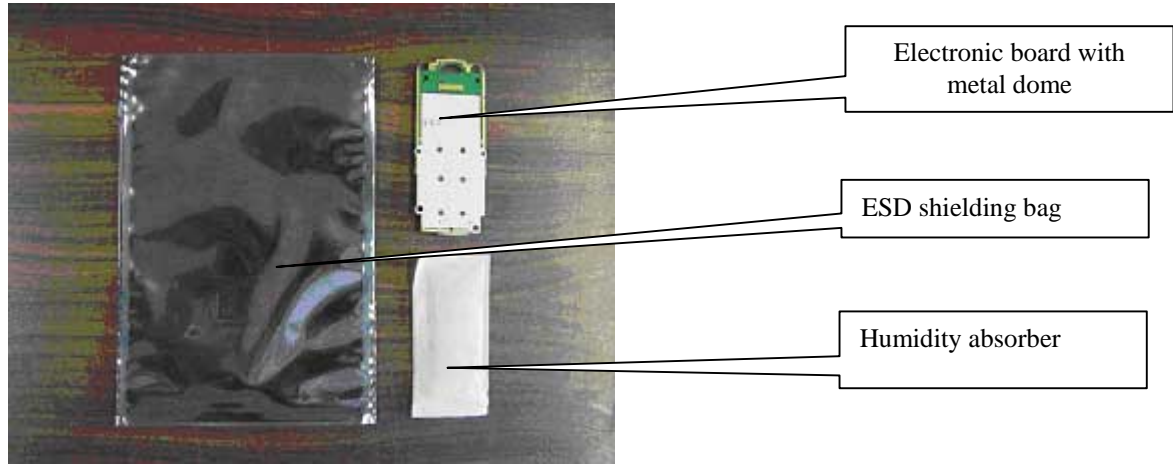

Boards packaging SAGEM -> ARC

Boards packaging ARC -> SAGEM



ESD shielding bag closed by the product label



ESD shielding bag closed by the IMEI label



SAGEM electrostatic shielding box  
 Reference 20 boards: 27441180-4  
 Reference 100 boards: 27 511110-6

	<b>ELECTRONIC BOARD EXCHANGE</b>	Proc sheet 1 10
myX-2		3/3

## Electronic board exchange process

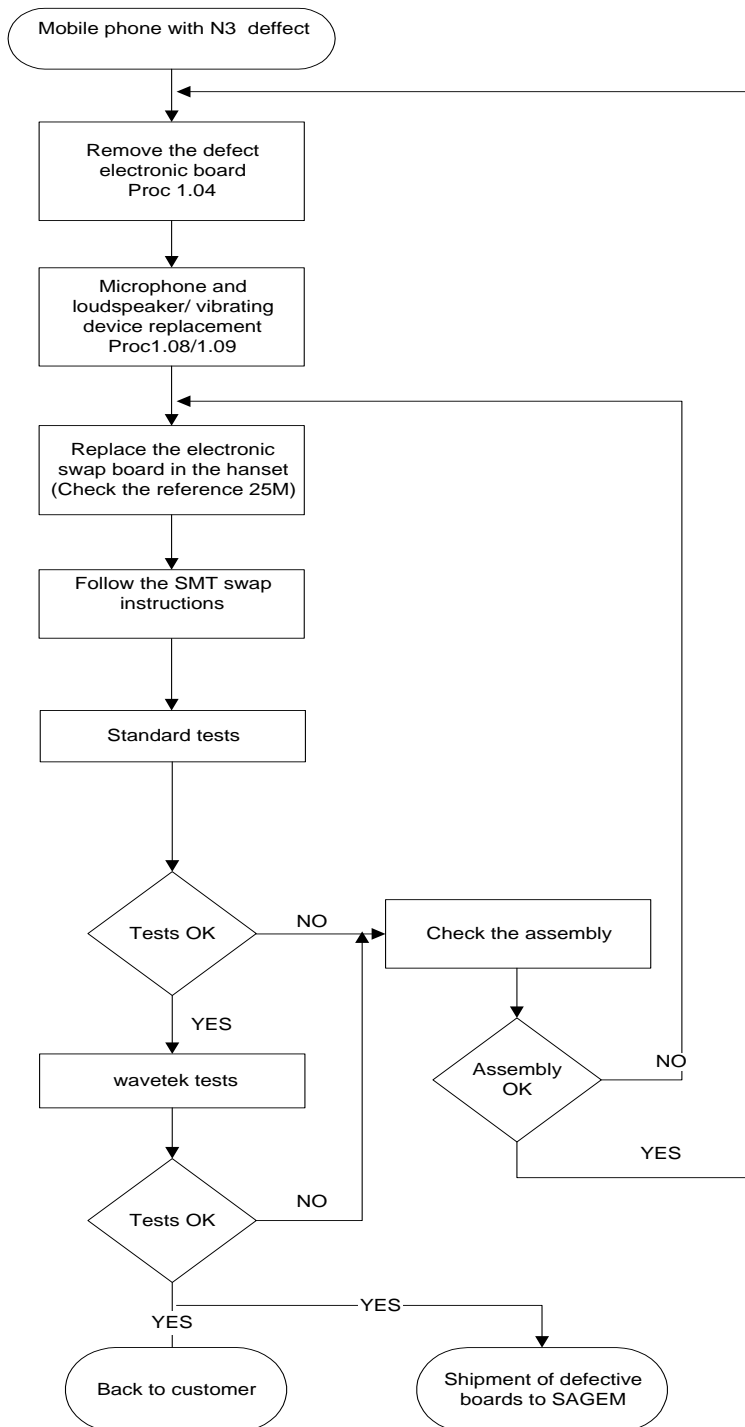

Detection of N3 defect : See the Technical documentation

-Check oxidation under the metal dome .

- Audio parameters written on the new swap board

- Display test : Hot Line Menu  
- Keypad test  
- Vibrating device test

- See Technical documentation (test sheet 06)

- Follow return instructions page 5-32

# **LEVEL 3 MAINTENANCE**

## **IMPORTANT**

### **Mobile packaging sent to SAGEM S.A. :**

Follow the Proc sheet 1.10

### **Packaging for swap or mobile components storage :**

The swap and the mobile components must be stored with a particular care especially for the most sensible component (Display , loudspeaker etc...).



<b>Informations CRA/CRA information :</b>		<b>Garantie/Warranty :</b>	
Nom/Name :		Garantie standard/Standard warranty :	
Rue /Street :		Déjà réparé/préviously repaired :	
Ville / City :		<b>Hors garantie/Out of warranty :</b>	
Code postal /Poscode :		Garantie expirée /Expired warranty :	
Pays/Country :		Mauvaise utilisation / Misuse :	
Telephone /Phone :			
Nom du produit/product :		N° Série/Sérial n° :	
Date d'achat/Date of purchase :		N° IMEI :	
Code SAGEM	Type de défauts	Type of fault	
<b>PROBLEME D'AFFICHAGE</b>			
A1	PAS D AFFICHAGE LED ETEINTES	DISPLAY PROBLEM	
A2	PAS D AFFICHAGE LED ALLUMÉES	NO POWER UP	
A3	BLOCAGE DE L AFFICHAGE	NO WAKE UP	
A5	AFFICHEUR CASSE	FREEZES UP	
A6	LIGNE, DIGIT OU PIXEL MANQUANT, CONTRASTE, COULEUR	BROKEN LCD	
A7	PB RETROECLAIRAGE	MISSING LINE, DIGIT or PIXEL, CONTRAST, COLOR	
<b>PROBLEME D'ANTENNE</b>			
A10	ANTENNE CASSEE / ABSENTE	ANTENNA PROBLEM	
<b>PROBLEME D'ALIMENTATION / CHARGEUR</b>			
B1	CONTACT BATTERIE DU MOBILE DEFECTUEUX	POWER SUPPLY / CHARGING PROBLEM	
B2	CONNECTEUR DE CHARGE DU MOBILE DEFECTUEUX	DEFECTIVE MOBILE BATTERY CONTACT	
B3	ALIMENTATION CARTE DEFECTUEUSE	DEFECTIVE MOBILE CHARGER CONNECTOR	
B4	AFFICHAGE CHARGE DEFECTUEUX	DEFECTIVE POWER SUPPLY OF THE BOARD	
B5	CONSOMMATION MODE ETEINT	DEFECTIVE CHARGE ICON DISPLAY	
B7	PROBLEME D AUTONOMIE	CURRENT CONSUMPTION WITH PHONE OFF	
B8	BATTERIE DEFECTUEUSE	AUTONOMY	
B9	TENUE MECANIQUE BATTERIE	ELECTRICALLY DEFECTIVE BATTERY	
B10	BATTERIE CASSEE	MECHANICAL LOCK PROBLEM ON BATTERY	
B11	CHARGEUR DEFECTUEUX	BROKEN BATTERY	
B12	CHARGEUR CASSE	DEFECTIVE CHARGER	
B13	COUPURE INTERMITTENTE AVEC REDEMARRAGE	BROKEN CHARGER	
B14	COUPURE INTERMITTENTE SANS REDEMARRAGE	INTERMITTENT SWITCH OFF WITH REBOOT	
<b>PROBLEME DE CLAVIER</b>			
C1	CLAVIER INOPERANT	KEYBOARD PROBLEM	
C2	PROBLEME TOUCHE LATERALE	NOT FUNCTIONING KEYBOARD	
<b>MESSAGE D'ERREUR</b>			
D1	SIM ABSENTE	ERROR MESSAGE	
D2	AUTRES MESSAGES	SIM MISSING	
D3	PB EEPROM	OTHER MESSAGES	
D4	MOBILE NON REGLÉ	EEPROM	
D5	HARD FAILURE	UNTUNED MOBILE	
D6	SIM VERROU	HARD FAILURE	
D7	CODE POSTE	SIM VERROU	
D8	RETOUR SAV	POST CODE BLOCKED	
D9	BATTERIE INCONNUE	SAV RETURN	
<b>PROBLEME AUDIO</b>			
E1	HP DEFECTUEUX (grésille)	AUDIO PROBLEM	
E2	HP VOIX DEFORMEE OU PARASITES	DEFECTIVE LOUDSPEAKER (hails)	
E3	MICRO DEFECTUEUX	LOUDSPEAKER VOICE DISTORTION	
E4	MICRO VOIX DEFORMEE OU PARASITE (DISTANT)	DEFECTIVE MICROPHONE	
E5	PROBLEME DE VIBREUR	MICRO VOICE DISTORTION	
E6	CONNECTEUR AUDIO DEFECTUEUX	VIBRATING DEVICE PROBLEM	
<b>PROBLEME DE COMMUNICATION</b>			
F1	PAS DE LOCALISATION RESEAU	COMMUNICATION PROBLEM	
F2	COUPURE DE COMMUNICATION	NO NETWORK RETRIEVAL	
F4	TEST RADIO NON OK	INTERMITTENT CALLS DROP	
F5	ECHEC APPEL SORTANT	TEST RADIO NO OK	
F6	ECHEC APPEL ENTRANT	OUTGOING CALL FAILURE	
F7	PERTE TEMPORAIRE DE RESEAU	INCOMING CALL FAILURE	
<b>PROBLEME COSMETIQUE / DEFAUT VISUEL</b>			
G1	VITRE CASSEE OU ABIMEE	COSMETIC PROBLEM	
G2	COQUE CASSEE OU ABIMEE	BROKEN OR DAMAGED GLASS	
G3	FLAP CASSE OU ABIME	BROKEN OR DAMAGED COVER	
G5	CLAVIER CASSE OU ABIME	BROKEN OR DAMAGED FLIP	
G6	BOUTON VERROU DEFECTUEUX	BROKEN OR DAMAGED KEYBOARD	
<b>AUTRES PROBLEMES</b>			
H1	KIT ACCESSOIRES HS	OTHER PROBLEM	
H2	FONCTION FM (MOBILE)	BROKEN OR DAMAGED ACCESSORY	
H3	FONCTION MONETIQUE	FM FUNCTION (Mobile)	
I1	TRACE D OXYDATION	MONETIC FUNCTION	
I3	PAS DE DEFAUT CONSTATE	OXYDATION MARKS	
I5	MANQUE FONCTION DANS MENU	NO FAULT FOUND	
I6	CONNECTEUR SIM DEFECTUEUX	LACK FUNCTION IN THE MENU	
I7	DYSFONCTIONNEMENT D'UNE FONCTION DU MENU	DEFECTIVE SIM CONNECTOR	
I8	RECONFIGURATION DU MOBILE	MALFUNCTION OF THE MENU	
<b>PROBLEME MULTIMEDIA</b>			
K1	PROBLEME DATA (SMS, EMS, SMS,GPRS, WAP, TELECHARGEMENT JEUX, SONNERIES, SAUVEUR D'ECRAN, NE COMMUNIQUE PAS AVEC UN PC, POCKET PC OU PALM)	MULTIMEDIA PROBLEM	
K2	FONCTION VIDEO	DATA PROBLEM (SMS, EMS, SMS,GPRS, WAP, DOWNLOADING GAMES, RINGING TONES, SCREEN SAVER, NO COMMUNICATION WITH A PC, POCKET PC or PALM)	
K3	FONCTION INFRAROUGE (IRDA )	VIDEO FUNCTION	
		INFRARED FUNCTION (IRDA)	

<b>Cachet du Vendeur/Dealer's Stamp :</b>		<b>Informations Client /Information :</b>	
		Nom/Name :	
		Rue /Street :	
		Ville / City :	
		Code postal /Postcode :	
		Pays/Country :	
		Telephone /Phone :	
Nom du produit/product :		N° Série/Sérial n° :	
Date d'achat/Date of purchase		N° IMEI :	
<b>Garantie/Warranty :</b>		<b>Hors garantie/Out of warranty :</b>	
Garantie standard/Standard warranty :		Garantie expirée /Expired warranty :	
Déjà réparé/préviously repaired :		Mauvaise utilisation / Missuse :	
Code SAGEM	Type de défaut	Kind of fault	
A0	AFFICHAGE DEFECTUEUX	DISPLAY MALFUNCTION	
A10	ANTENNE CASSEE / ABSENTE	ANTENNA BROKEN / MISSING	
B0	ALIMENTATION/CHARGE	POWER SUPPLY / NO CHARGE	
B7	PROBLEME D'AUTONOMIE	AUTONOMY	
B8	BATTERIE DEFECTUEUSE	BROKENBATTERY	
B11	CHARGEUR DEFECTUEUX	CHARGER MALFUNCTION	
C0	PROBLEME CLAVIER	KEYBOARD MALFUNCTION	
C2	PROBLEME TOUCHE LATERALE	LATERAL TOUCH PROBLEM	
D0	MESSAGE D'ERREUR	ERROR MESSAGE	
D1	SIM ABSENTE	SIM MISSING	
D7	CODE POSTE	POST CODE BLOCKED	
E0	PROBLEME AUDIO	AUDIO PROBLEM	
E3	MICRO DEFECTUEUX	MICROPHONE MALFUNCTION	
E5	PROBLEME DE VIBREUR	VIBRATING DEVICE MALFUNCTION	
F0	PROBLEME DE COMMUNICATION	COMMUNICATION MALFUNCTION	
G1	VITRE CASSEE OU ABIMEE	BROCKEN GLASS	
G2	COQUE CASSEE OU ABIMEE	BROCKEN COVER	
G3	FLAP CASSE OU ABIME	BROKEN FLIP	
G5	CLAVIER CASSE OU ABIME	BROCKEN KEYBOARD	
G6	BOUTON VERROU DEFECTUEUX	DEFECTIVE LOCK BUTTON	
K2	FONCTION VIDEO	VIDEO FUNCTION	
K3	FONCTION INFRAROUGE (IRDA )	INFRARED FUNCTION (IRDA)	
K4	FONCTION WAP	WAP FUNCTION	
K5	FONCTION GPRS	GPRS FUNCTION	
K6	FONCTION SMS, EMS, MMS.	SMS, EMS, MMS FUNCTION	
K7	NE COMMUNIQUE PAS AVEC UN PC	NO COMMUNICATION WITH A PC	
K8	NE COMMUNIQUE PAS AVEC UN POCKET PC OU PALM	NO COMMUNICATION WITH A POCKET PC or PALM	
K9	LIAISON DATA (MESSAGE "AUCUNE PORTEUSE DETECTEE")	DATA ( MESSAGE "NO CARRIER DETECTED")	
K10	TELECHARGEMENT JEUX	DOWNLOADING GAME	
K11	TELECHARGEMENT IMAGE / SON / ECONOMISEUR D'ECRAN	DOWNLOADING PICTURE / RINGTONE / SCREEN SAVE	
H1	KIT ACCESSOIRES HS	BROCKEN ACCESSORIES	
H2	FONCTION FM (MOBILE)	FM FUNCTION	
H3	FONCTION MONETIQUE	MONETIC FUNCTION	
I5	MANQUE FONCTION DANS MENU	LACK FUNCTION IN THE MENU	
I7	DYSFONCTIONNEMENT D'UNE FONCTION DU MENU	MALFUNCTION OF THE MENU	
I8	RECONFIGURATION DU MOBILE	MOBILE RETROFIT	
I0	AUTRES DEFAUTS A PRESICER	OTHERS / TO BE PRECISED	

# **OUT OF WARRANTY INTERVENTION**

	<b>REMOVING/ REPLACING THE SMK CONNECTOR</b>	Proc Sheet 4 01
myX-2		1/3

**Notice:** The handsets requiring the replacement of system connectors cannot be repaired under Sagem warranty.

The eventual deterioration of the board due to a bad replacement of the connector fall under the Repair Centre responsibility.

**- Replacement procedure of SMK connector**

- 1-Disassemble the handset Proc 1 04
- 2-Replace the defective connector (see below) **Ref 18 598 906-8**
- 3 - Replace the electronic board in the mobile phone Proc 1 04
- 4 -To test the replacement of the connector, it is necessary to:
  - a) Connect the mobile phone on SMT maintenance software (test Sheet 01)
  - b) Make real calls with a pedestrian handsfree Kit **Reference :23 812 517-0**
  - c) Test the charge of mobile phone
- 5 - Standard test after repair

	<b>REMOVING/ REPLACING THE SMK CONNECTOR</b>	Proc Sheet 4 01
myX-2		2/3

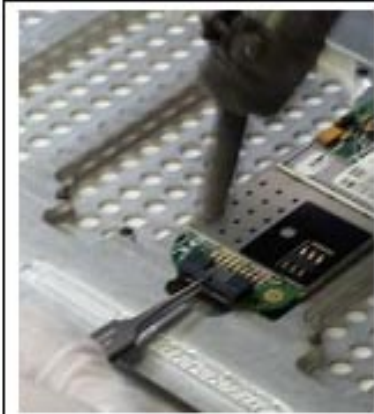

- Maintain the electronic board
  - flux Correctly the pins of the connector.
  - Reference of the flux to be used:
  - LITTON flux -Supplier reference 952-D6  
-SAGEM reference 18 775 103-7
  - With tweezers, hold the connector and heat the pins up.
- ATTENTION:**
- Do not pull the connector but let it come , in order to avoid destroying the pads

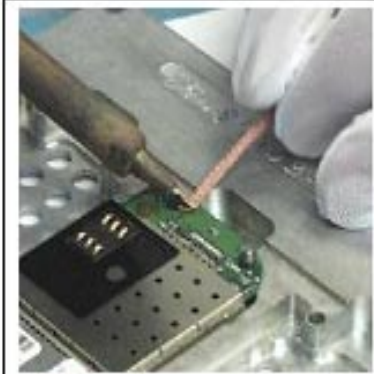

After having removed the connector, uncork rather quickly the four holes of the connector while the tin is still warm.



Flux and heat the pads in place of the connector to equalise the foot prints



In order to tin the pins of the SMK , load the solder wick with tin on approximately 1 inch.

	<b>REMOVING/ REPLACING THE SMK CONNECTOR</b>	Proc Sheet 4 01
myX-2		3/3



Before any operation,  
- flux correctly the pins of the connector.  
- with the solder wick loaded with tin , tin the pins of the SMK by positioning it straight ahead (pads upward), and by heating the solder wick which is in touch with pins.

**Attention:**  
- At the end of the operation , verify that there is no short circuit between pads.



-Start soldering the connector pins.  
-Flux the place of the connector and position the SMK.  
-Verify that the pins of the SMK are well centred on pads.  
-Heat pins with an air blow device while maintaining the connector with tweezers  
-Verify that there is no short-circuit, that solders are shiny and that they cover well the pins

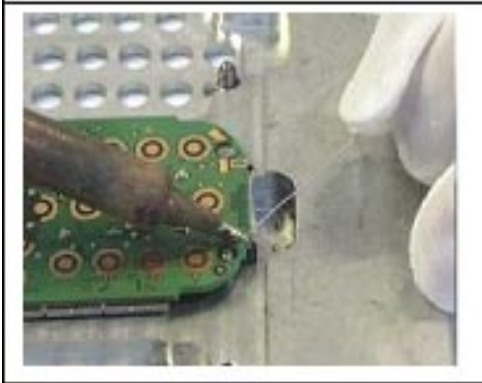

At last, solder the 4 pins crossing the board..

## CHAPTER 6 - ACCESSORIES

### 6.1 12 V / 24 V CHARGERS

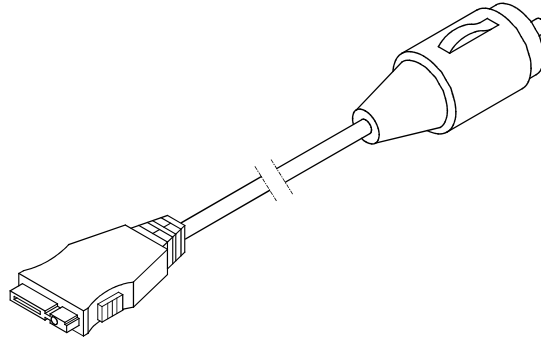

#### 6.1.1 Description

This charger is for use in a car (or truck) only. The adapter is fitted with a cigar lighter type connector. AC1 is used to charge a mobile on a cigar lighter connector.

#### 6.1.2 Characteristics

Item	Packaging reference	Input voltage	No load voltage	Output current	Comments
CIGAR LIGHTER CHARGER AC1	Blister	10.8 to 30 V=	6.5 V	500 mA	

**6.2 DESKTOP CHARGERS AND CRADLES**

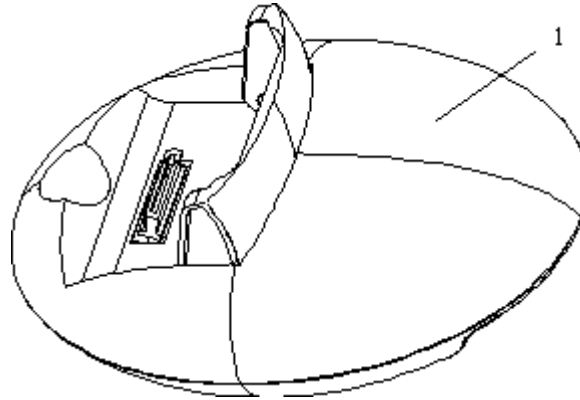

**6.2.1 Description**

This charger could charge a mobile, while acting as holder the handset.

**6.2.2 Characteristics**

Item	Designation	Nature
1	SIMPLE DESKTOP CRADLE	Simple support recess

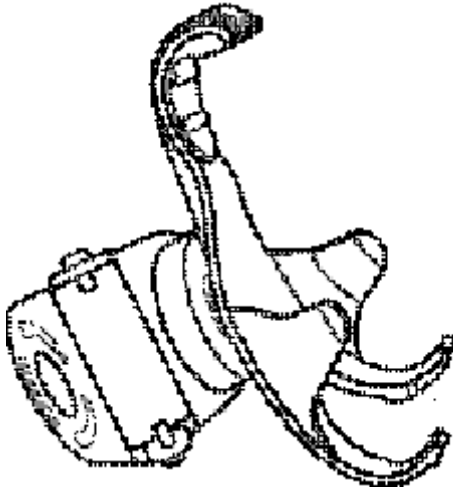

**6.3 CAR CRADLE****6.3.1 Description**

Car cradle compatible with AC1 or antenna adapter.

**6.3.2 Characteristics**

Item	Packaging	Comments
CAR CRADLE KIT mechanical	BLISTER	Mechanical cradle

**6.4. FULL DUPLEX CAR HANDSFREE KIT**

**6.4.1. Description**

Rapido Kit : "compact" kit on cigar lighter,  
 K3 Kit : "confort" kit for integration in car with phone equipment.

**6.4.2. Characteristics**

Item	Packaging	Comments
Rapido kit	Box	No antenna.

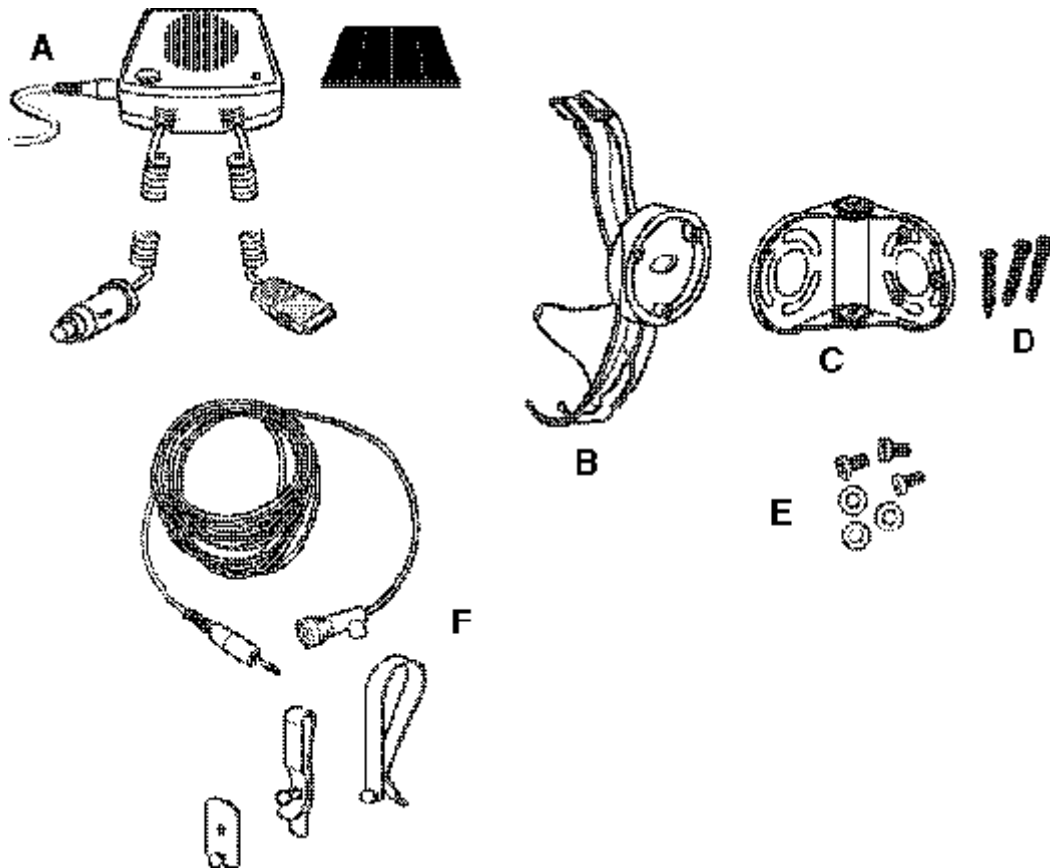

- A : Connecting case and loudspeaker.
- B : Cradle.
- C, D et E : Support kit.
- F : Microphone.

Item	Packaging	Comments
K3 KIT	Box	No antenna. Requires car installation 900/1800 MHz dual band

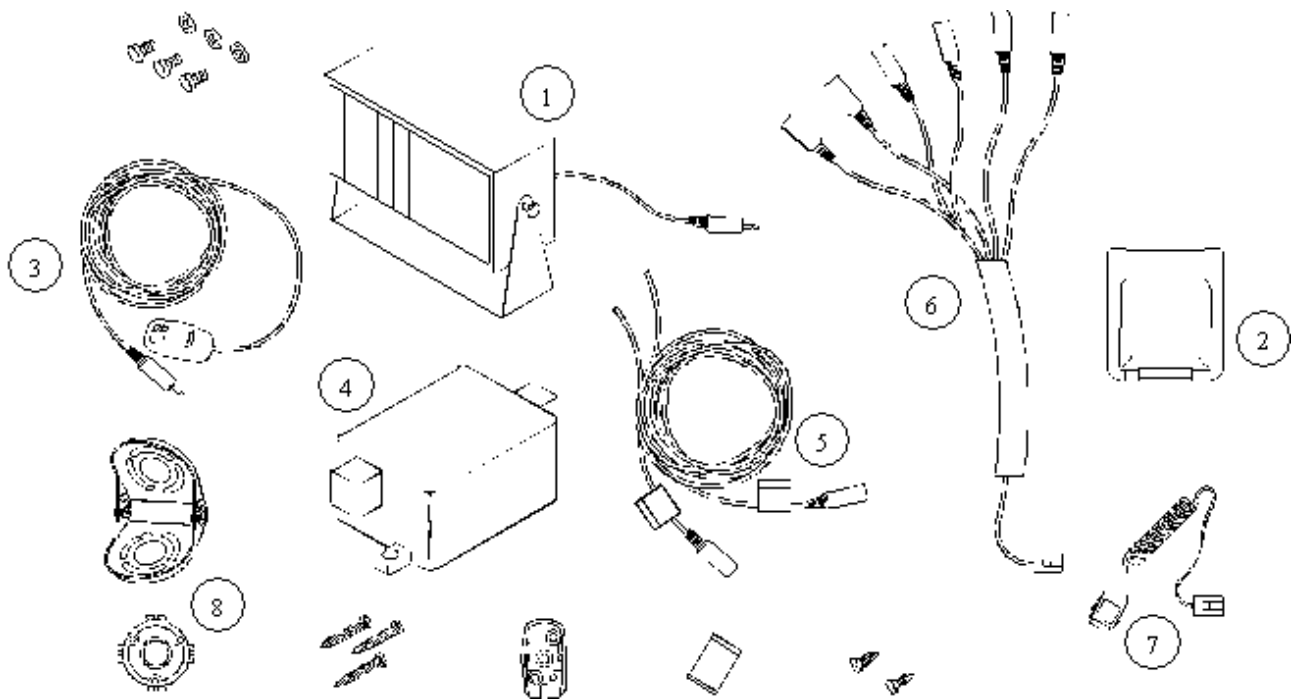

- 1 : Loudspeaker.
- 2 : Cradle.
- 3 : Microphone.
- 4 : Connecting case.
- 5 : Power supply cable.
- 6 : Cable : microphone, loudspeaker, car ⇔ connecting case.
- 7 : Cable : mobile ⇔ connecting case.
- 8 : Support kit.

**6.5 PEDESTRIAN HANDSFREE KIT**

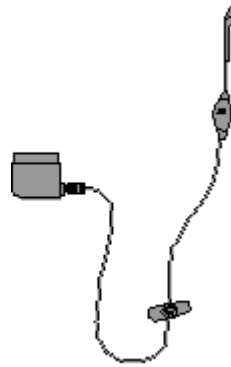

**6.5.1 Description**

Ear support with microphone on the cable for handsfree conversation.

**6.5.2 Characteristics**

Item	Dimensions	Loudspeaker impedance	Microphone
PEDESTRIAN HANDSFREE KIT	Length: 1.25 m Dist. micro/loudspeaker: 25 cm	150 Ω 119 dB SPL	2,2 kΩ -42 dB SPL

## 6.6 DATA CABLES

### 6.6.1 Description

Data cables are used for transferring data through standard equipment.

### 6.6.2 Characteristics

Item	Packaging	Target mobile	Mobile link to	Signals
DATA CABLE	Blister	Range 900/3000/myX- 3/myX-5	PC	Standard V28 3V<Us<-3V  Fmax = 115kbauds
DATA CABLE	Blister	myX-5/ myX-2	PC	

## **CHAPTER 7 - TECHNICAL INFORMATION BULLETIN**

### **7.1 PURPOSE**

The purpose of the Technical Information Bulletin (TIB) is to complete the maintenance operations described in this document. They give to the repair centers the complementary technical informations and the corrective procedures to be applied to maintain the product following it's evolution.

### **7.2 APPLICATION**

The Technical Information Bulletin (TIB) are reference and must be applied by the repair centers.

The Technical Information Bulletin (TIB) will be sent only to the concerned repair centers. The Technical Data Bulletin will not be received by the repair centers with a reference number in sequence.

The follow up of the Technical Information Bulletin (TIB) and the action being to be performed are under the responsibility of the repair centers.

## CHAPTER 8 - ILLUSTRATED PART CATALOG

### 8.1 myX-2 spare parts

ASSEMBLY	QTY	DESIGNATION
10	1	Front cover
15	1	Elastomer keyboard
20	1	Rear cover
25	1	Assembly plate
30	1	Metal dome
35	1	Light guide keypad
40	6	RLX 1,8-6 screw
45	1	color display
50	1	Display clamp
55	1	Plate
60	1	Microphone
65	1	SIM locker
70	1	Battery connector
75	1	Loudspeaker/ vibrating device

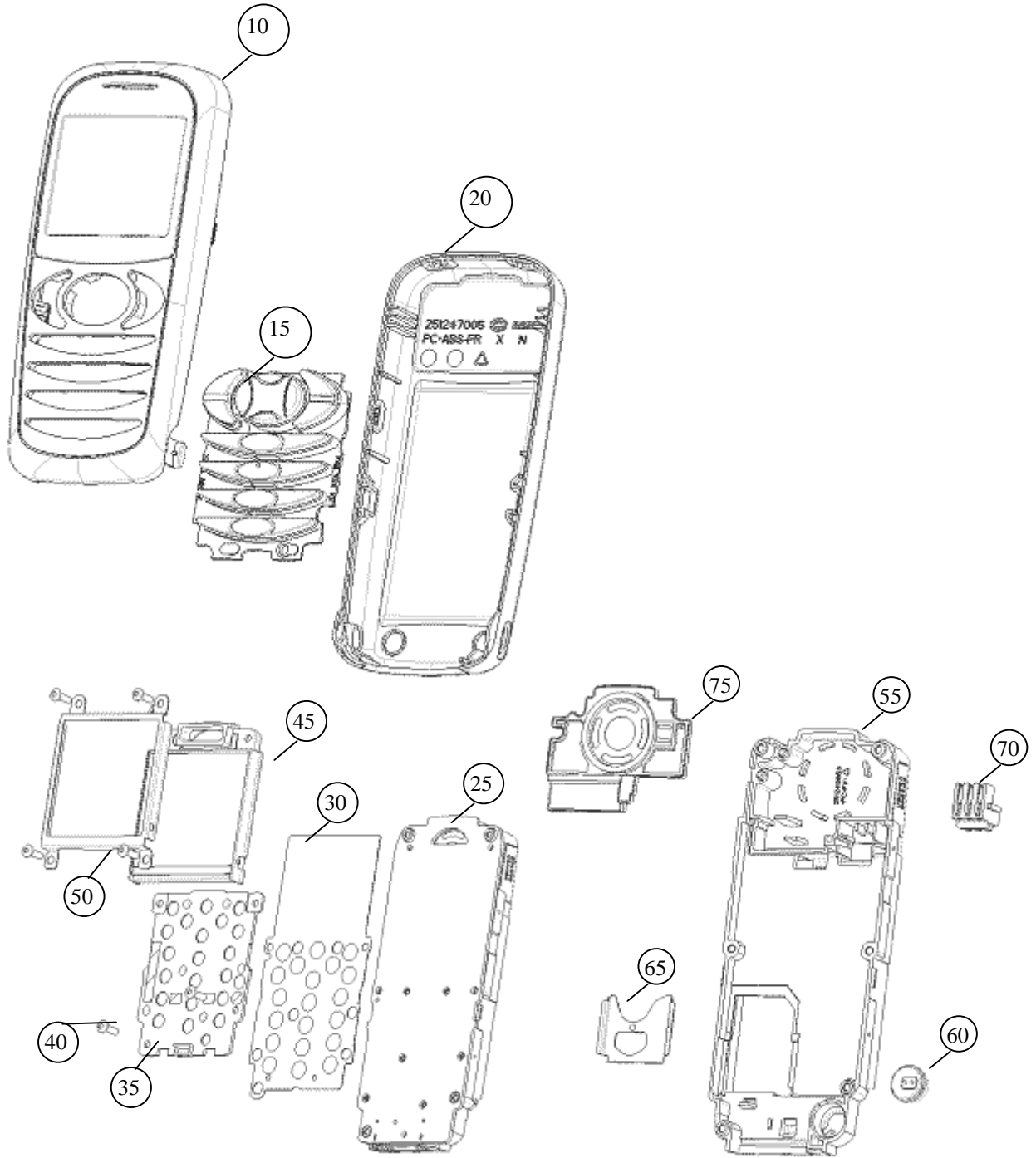



## APPENDIX 1 - COMPOSITION TABLE

### A 1.1 PURPOSE

This chapter contains the SAGEM codes of articles mentioned throughout the Site Technical Documentation.

### A 1.2 LIST OF ARTICLES

<b>TEST TOOLS</b>	
<b>Designation</b>	<b>Reference</b>
Secured downloading kit	23 810 395-5
Mains charger test kit	23 810 480-8
myX-2 LCD/Metal dome jig	25 134 049-7
myX-2 radio interface	25 130 038-6
myX-2 ammeter interface	25 130 973-0

<b>12 V / 24 V CHARGERS</b>	
<b>Designation</b>	<b>Reference</b>
Cigar-lighter charger AC1	23 810 045 - 9

<b>DESKTOP CHARGERS</b>	
<b>Designation</b>	<b>Reference</b>
Desktop charger	23 812 376 - 7

<b>FULL DUPLEX CAR HANDSFREE KIT</b>	
<b>Designation</b>	<b>Reference</b>
Kit K3	23 811 416 - 4
Rapido Kit	23 811 861 - 7
Simple car support	23 812 339 - 5

<b>PEDESTRIAN HANDSFREE KIT</b>	
<b>Designation</b>	<b>Reference</b>
Pedestrian handsfree kit	23 812 517-0