



SITE TECHNICAL DOCUMENTATION

GSM 900/1800 - myX-3 & myX-5

Doc. No. : SCT U38 SSC DTS 009

Version : B

Date : December 12 , 2002

Produced by **SAGEM SA**
2, rue du Petit Albi, 95800 Cergy Saint-Christophe, France
Tel (33) 1 30 73 50 50 - Fax (33) 1 30 73 50 55

Copyright © 2002
SAGEM
Cergy Saint-Christophe, France

NON DISCLOSURE AGREEMENT

This document is SAGEM SA property. It can not be copied or communicated in all or part without written authorisation.

CONTENTS

CHAPTER 1 - FOREWORD

1.1	HOW TO USE THE SITE TECHNICAL DOCUMENTATION.....	1-1
1.2	ABBREVIATIONS	1-2
1.3	COMMENTS SHEET	1-3

CHAPTER 2 - DESCRIPTION - OPERATION

2.1	REMINDERS ABOUT THE GENERAL CHARACTERISTICS OF GSM AND PCS NETWORKS.....	2-1
2.2	REMINDERS ABOUT THE CHARACTERISTICS OF myX-3 & myX-5	2-3
2.3	SMK CONNECTOR.....	2-5
2.3.1	Connector description	2-5
2.3.2	Signal description.....	2-5
2.4	IDENTIFICATION	2-7
2.4.1	Illustration.....	2-7
2.4.2	Description	2-7
2.4.3	Description after reparation	2-7
2.5	PHONE BLOCK DIAGRAM.....	2-8
2.5.1	myX-3 & myX-5 block diagram	2-8
2.5.2	Standards and environment.....	2-8
2.6	EQUIPEMENTS.....	2-9
2.6.1	Battery packs	2-10
2.6.2	Mains modules.....	2-10

CHAPTER 3 - SYMPTOMS

3.1	GENERAL.....	3-1
3.2	SHORT LOOP PROCESS.....	3-2
3.3	LIST OF REPORTED DEFECTS	3-5
3.4	ERROR MESSAGES DURING START UP	3-7
3.5	OTHER ERROR MESSAGES	3-7
3.6	LIST OF OBSERVED DEFECTS	3-9
	SYMPTOM SHEET.....	3-10
	SYMPTOM SHEET 01 : ENDURANCE BATTERY CHARGER.....	3-11
	SYMPTOM SHEET 02 : COMMUNICATION.....	3-12
	SYMPTOM SHEET 03 : NO FAULT GIVEN.....	3-13

SYMPTOM SHEET 04 : DISPLAY.....	3-14
SYMPTOM SHEET 05 : KEYPAD.....	3-15
SYMPTOM SHEET 06 : RING TONES.....	3-16
SYMPTOM SHEET 07 : VIBRATE.....	3-17
SYMPTOM SHEET 08 : MICROPHONE / LOUDSPEAKER.....	3-18

CHAPTER 4 - TESTS AND CHECKS

4.1 GENERAL ABOUT TESTS	4-1
4.2 TEST TOOLS	4-1
4.3 INSTALLING ON A WORKSTATION.....	4-2
4.3.1 Minimum required configuration	4-2
4.3.2 Installing the CRA downloading kit	4-2
4.3.3 OMM functions.....	4-2
TEST SHEET.....	4-3
TEST SHEET 01 : TEST CHECK BY OMM	4-4
TEST SHEET 02 : CHARGER TEST.....	4-13
TEST SHEET 03 : BATTERY TEST.....	4-14
TEST SHEET 04 : CONSUMPTION TEST.....	4-15
TEST SHEET 05 : "HOTLINE" MENU	4-16
TEST SHEET 06 : RADIO TEST.....	4-18

CHAPTER 5 – MAINTENANCE PROCEDURES

5.1 TECHNICAL WORK LEVELS.....	5-1
5.2 MAINTENANCE TOOLS	5-1
LEVEL 0 MAINTENANCE.....	5-2
PROCEDURE SHEET 0 01 : REMOVING AND REPLACING THE BACK COVER.....	5-3
PROCEDURE SHEET 0 02 : REMOVING AND REPLACING THE BATTERY	5-5
PROCEDURE SHEET 0 03 : REMOVING AND REPLACING THE FRONT COVER.....	5-7
PROCEDURE SHEET 0 04 : REMOVING AND REPLACING THE KEYPAD.....	5-9
PROCEDURE SHEET 0 05 : REMOVING AND REPLACING THE KNOB LOCK.....	5-11

LEVEL 1 MAINTENANCE.....	5-13
PROCEDURE SHEET 1 02 : REMOVING AND REPLACING THE DISPLAY.....	5-14
PROCEDURE SHEET 1 03 : REMOVING AND REPLACING THE LIGHT GUIDE KEYPAD.....	5-16
PROCEDURE SHEET 1 04 : REMOVING AND REPLACING THE ELECTRONIC BOARD.....	5-18
PROCEDURE SHEET 1 05 : REMOVING AND REPLACING THE METAL DOME.....	5-20
PROCEDURE SHEET 1 06 : REMOVING AND REPLACING THE SIM LOCKER.....	5-22
PROCEDURE SHEET 1 07 : REMOVING AND REPLACING THE BATTERY CONNECTOR.....	5-24
PROCEDURE SHEET 1 08 : REMOVING AND REPLACING THE MICROPHONE.....	5-26
PROCEDURE SHEET 1 09 : REMOVING AND REPLACING THE LOUDSPEAKER.....	5-28
PROCEDURE SHEET 1 10 : REMOVING AND REPLACING THE VIBRATING DEVICE.....	5-30
PROCEDURE SHEET 1 11 : ELECTRONIC BOARD EXCHANGE.....	5-32
LEVEL 3 MAINTENANCE	5-35
PROCEDURE SHEET 3 01 : RETURN TO SAGEM FACTORY.....	5-37
PROCEDURE SHEET 3 02 : RETURN TO CUSTOMER.....	5-38

CHAPTER 6 - ACCESSORIES

6.1 12 V / 24 V CHARGERS.....	6-1
6.1.1 Description	6-1
6.1.2 Characteristics	6-1
6.2 DESKTOP CHARGERS AND CRADLES	6-2
6.2.1 Description.....	6-2
6.2.2 Characteristics	6-2
6.3 CAR CRADLE.....	6-3
6.3.1 Description	6-3
6.3.2 Characteristics	6-3
6.4 FULL DUPLEX CAR HANDSFREE KIT	6-4
6.4.1 Description	6-4
6.4.2 Characteristics	6-4
6.5 PEDESTRIAN HANDSFREE KIT	6-6
6.5.1 Description	6-6
6.5.2 Characteristics	6-6
6.6 DATA CABLES	6-7
6.6.1 Description	6-7
6.6.2 Characteristics	6-7

CHAPTER 7 – TECHNICAL INFORMATION BULLETIN

7.1 PURPOSE	7-1
7.2 APPLICATION	7-1

CHAPTER 8 – ILLUSTRATED PARTS CATALOG

8.1 myX-3 SPARE PARTS	8-1
8.2 myX-5 SPARE PARTS	8-3

APPENDIX 1 – COMPOSITION TABLE

CHAPTER 1 - FOREWORD

This document is common to myX-3 and myX-5 SAGEM phones. It is composed of independent sheets:

- Symptom sheets = Symp Sheet XX
- Test and check sheet = Test Sheet XX
- Maintenance procedure sheet = Proc Sheet X XX

The applicability of a procedure is indicated in the independent sheets title block:

- All types = GSM 900, GSM 1800 and dual band.

These sheets are updated from time to time in Technical Information Bulletins (TIB).

The information contained in this document is non-contractual, since phone characteristics can change.

Phones are managed based on SAGEM handset codes; any order for spare parts must refer to these codes (typical code 25 xxx xxx-x).

1.1 HOW TO USE THE SITE TECHNICAL DOCUMENTATION

This is a modular document. Each sheet is unique and independent. In some cases several sheets may have to be used in order to determine the complete procedure to be applied.

A troubleshooting chapter (chapter 3) is provided and is sorted according to the type of reported fault, to determine the maintenance procedure to be carried out.

These sheets describe the procedure to be followed. They refer to test sheets or removal and replacement maintenance sheets. Maintenance ,executed by the repair center, terminates either by returning the product to the customer, or by dispatching it to level 3 maintenance (return to factory).

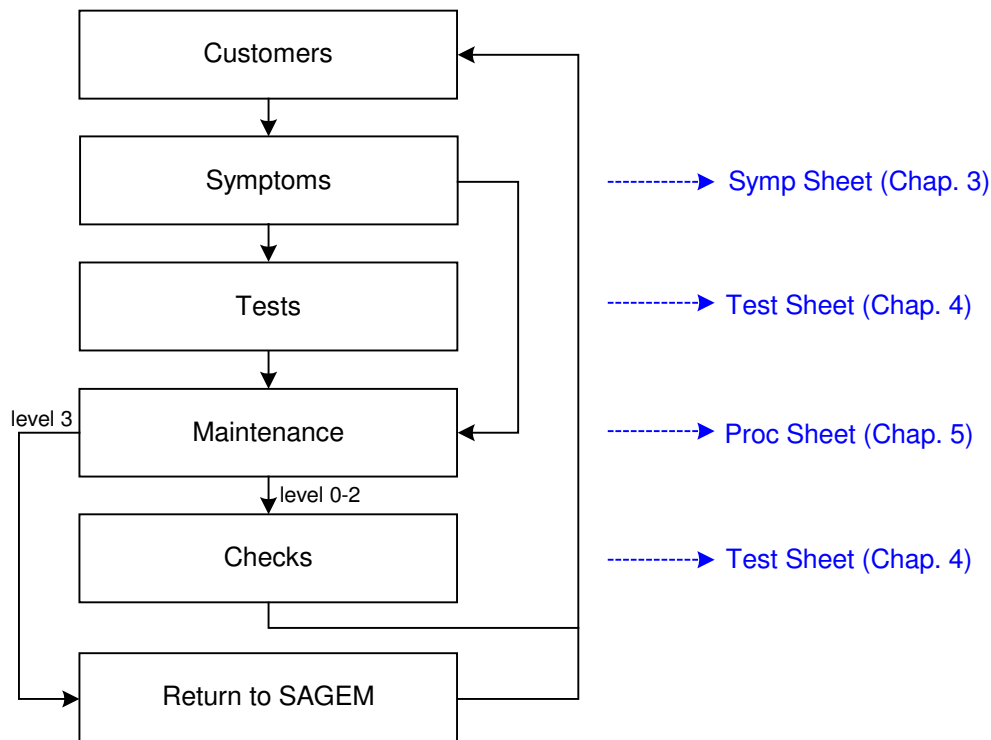

All sheets include illustrations to make it easier to read the procedure.

- **Chapter 1: Foreword**, describes general data about this document.
- **Chapter 2: Description - Operation**, describes general data and options available in the myX-3 & myX-5.
- **Chapter 3: Symptoms**, contains troubleshooting procedures to be carried out on equipment.
- **Chapter 4: Tests and checks**, contains tests and check procedures to be performed on the equipment.
- **Chapter 5: Maintenance procedures**, contains level 0 to 2 maintenance procedures to be carried out on the equipment, and the procedure to return to SAGEM level 3.
- **Chapter 6: Accessories**, describes the characteristics of accessories for myX-3 & myX-5 phones .
- **Chapter 7: Technical Information Bulletins**, contains the various modifications made to this documentation.
- **Chapter 8: Illustrated Parts Catalogue**, contains the various reference for spare parts.
- **Appendix 1: Composition table**, contains the various Sagem references codes for equipment described in this document.

1.2 ABREVIATIONS

ALS	Alternative Line Services
AOC	Advice Of Charge
CLI	Calling Line Identification
CLIP	Calling Line Identification Presentation
CLIR	Calling Line Identification Restriction
COLP	Connected Line identification Presentation
COLR	Connected Line identification Restriction
DCS	Digital Cellular System
EFR	Enhanced Full Rate
EMS	Enhanced Message Service
FDN	Fix Dial Number
GPRS	General Packet Radio Service
GSM	Global System for Mobile
IMEI	International Mobile Equipment Identity
ISO	International Standard Organisation
LU	Livret d'Utilisation (User's Guide)
ML	Mains Libres (Hand Free)
MMS	Multimedia Message Service
OMM	Outils de Maintenance des Mobiles (Mobiles Maintenance Tools)
PCS	Personal Communication Services
PIN	Personal Identity Number
PUK	PIN Unlocking Key
SAR	Specific Absorption Rate

SIM	Subscriber Identify Module
SMS	Short Message Service
SMS MT	Short Service Message Mobile Terminating
SMS MO	Short Service Message Mobile Originating
SMS CB	Short Service Message Cell Broadcast
TDMA	Time Division Multiple Access
USSD	Unstructured Supplementary Service Data
WAP	Wireless Application Protocol

1.3 COMMENTS SHEET

Broad experience is very beneficial in several respects. Please let us know your comments so that we can improve the contents and presentation of this document.

Your suggestions will be read carefully by :

- the design laboratory,
- production,
- the purchasing department,
- the after sales service,
- all users of this document.

All your suggestions are valuable, they will help us to better satisfy you.

Please photocopy and fill in the sheet 1-4.

Document title: **Site Technical Document for myX-3 & myX-5**

Reference :

Date : December 2002

Please fill in the following table :

	Excellent	Good	Fairly good	Passable
Easy to find the required information				
Clarity of information provided				
Quality and accuracy of information given				
Document outline				
Document presentation and appearance				
Quality of illustrations				
General satisfaction				

Do you think this document could be improved ? if so, how ? :

- Improve the overall view
- Improve the table of contents
- Improve the structure
- Add illustrations
- Add details
- Add information

Comments : _____

Would you like to discuss the problems mentioned in this questionnaire? If so, state :

Name of the person to be contacted : _____ Phone : _____

Company : _____ Date : _____

Address : _____

THANK YOU FOR PARTICIPATING IN THIS ENQUIRY. YOUR COMMENTS WILL HELP US CONTINUE TO IMPROVE THE QUALITY OF OUR DOCUMENTATION AND THUS BETTER SATISFY YOUR NEEDS.

When you have filled in this questionnaire, please send it :

- by fax, to +33 (0) 1 30 30 17 86

- by mail, to **SAGEM S.A.**
 Support Service Client / URD 38
 2 rue du petit Albi
 BP 8250
 95 801 Cergy Saint-Christophe

CHAPTER 2 - DESCRIPTION - OPERATION

2.1 REMINDERS ABOUT THE GENERAL CHARACTERISTICS OF GSM, (900 et 1800) AND PCS (GSM 1900) NETWORKS

Table 1 below gives the characteristics of the radio interface for the GSM 900, GSM 1800 and GSM 1900 systems :

	GSM 900	GSM 1800	PCS 1900
Frequency Band (MHz)	890 - 915 925 - 960	1710 - 1785 1805 - 1880	1850 - 1910 1930 - 1990
Number of time intervals per TDMA frame	8		
Width 2 x W simplex (MHz)	2 x 25	2 x 75	2 x 60
Duplex spacing (MHz)	45	95	80
Modulation speed (kbit/s)	271		
Speech throughput (kbit/s)	13 (5,6)		
Maximum data throughput (kbit/s)	12		
Multiple access	Frequency and temporal multiplexing / frequency duplexing		
Cell radius (km)	0,3 to 30	0,1 to 4	0,1 to 4
SAGEM terminal power (W)	2	1	1
Table 1 : Radio Interface			

Table 2 shows powers as a function of the network :

Class number	GSM 900		GSM 1800		PCS 1900	
	Maximum nominal power (W)	Allowable interval (W)	Maximum nominal power (W)	Allowable interval (W)	Maximum nominal power (W)	Allowable interval (W)
1	-	-	1	[0,63 ; 1,6]	1	
2	8	[5,0 ; 12,7]	0,25	[0,16 ; 0,4]	0,25	
3	5	[3,2 ; 7,9]	4	[2,5 ; 6,3]	2	
4	2	[1,3 ; 3,2]				
5	0,8	[0,5 ; 1,3]				
Table 2: Terminals power class						

Table 3 shows power classes :

	Class 1	Class 2	Class 3	Class 4	Class 5
900	43 dBm	39 dBm	37 dBm	33 dBm	29 dBm
1800	30 dBm	24 dBm	36 dBm	-	-
1900	30 dBm	24 dBm	33 dBm	-	-
Table 3: RF power classes					

2.2 REMINDERS ABOUT THE CHARACTERISTICS AND OPTIONS OF myX-3 & myX-5 MOBILES

GENERAL CHARACTERISTICS	myX-3	myX-3d	myX-5	myX-5d
Weight (in g) :	92		92	
Dimensions (in mm) :	106*46*20		105*46*20	
Volume (cm3)	77			
Standby (h) :	240			
Talk time (h/mn) :	4			
Screen size (pixels), Colour, Back light :	Black & White , Blue backlight		101*80 in 256 colours	
Line / character number of the screen :	8 lines			
Battery Type	Li Ion			
Recharge Time	2h30			
RADIO CAPACITY				
GSM 900, 1800 - EGSM	Yes			
GSM 1900	No (PCS range)			
GPRS and type (2+1 / 3+1....)	3+1 ciphering			
Voice Quality	FR, HR, EFR			
COSMETIC				
Painted	6 choices		Stainless Steel	
Keypad	Metallic		Metallic	
USEFUL FEATURES				
WAP (1,1 / 1,2...)	1,2			
Built in Hands Free	Yes			
Vibrating device - Silent Mode	Yes			
Alarm / Clock	Yes			
Direct access keys (ADN / SMS / WAP)	Yes			
SMS notification	Yes			
Predictive input (Y/N + type)	Yes (T9)			
Voice commands	No			
Bis (number)	20			
EMS	Yes (R5)			
MMS	No		Option	
ENTERTAINMENT / FUN FACTS				
Mservices	Yes			
Animated Screensaver	Up to 5 (downloadable through DF*)		Up to 5 (downloadable through DF*)	
Wallpaper or fix screensaver	No		Up to 30 (downloadable through DF*)	
Icons	Up to 45 (downloadable through DF*)		Up to 50 (downloadable through DF*)	
Polyphonic ringtone / number of tones	Up to 65 / 8 tones (downloadable through DF*)		Up to 80 / 8 tones (downloadable through DF*)	
Games :nb , download	2 embedded + 1 download (In Fusio in option)		Up to 2 (In Fusio in option)	
Java	Partially			
Interchangeable covers	Yes (front&back)			

MULTIMEDIA	myX-3	myX-3d	myX-5	MyX-5d
Picture formats	bmp, jpeg, png, gif			
Audio formats	iMelody1.2, Midi, Wave			
Music file reproduction	No possibility to forward a polyphonic tone			
Integrated still picture camera	No			
MEMORY				
Internal Phone Book (positions)	up to 250		up to 300	
Internal SMS Memory (positions)	up to 50		up to 100	
Redial List / Notebook (positions)	up to 20			
Additional Memory	No			
DATA TRANSMISSION				
IRDA	No	Yes	Yes	Yes
Integrated modem	No	Yes	No	Yes
Fax application	No	Yes	No	Yes
Bluetooth (integrated / add-on)	No			
e-mail client	No			

- **Download Fun service**

Remark : This information is given for guidance , and is in no way contractual characteristics vary according to customers and countries.

2.3 SMK CONNECTOR

2.3.1 Connector description

This connector is located at the bottom of the transmission module and enable the connection to various accessories. It comprises power supply pins and signals.

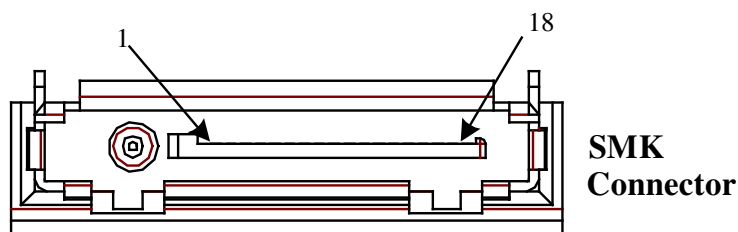

2.3.2 Signal description

SYMBOL	PIN CONNECTOR No.	SIGNAL FUNCTION	NATURE E/S, AI, Ana
CHARGEUR	1	Phone set power ON and power supply signal.	POWER SUPPLY
VBAT	2	POWER SUPPLY IMAGE VOLTAGE, connect this signal to «CHARGER» (pin n°1) to switch the module on.	POWER SUPPLY OUTPUT
ON*	3	SIGNAL RESERVED FOR USE BY SAGEM (car handsfree kit).	OPEN DRAIN OUTPUT
VPP	4	Flash programming voltage	POWER SUPPLY
SDAI2C	5	DATA SIGNAL RESERVED FOR SAGEM SPECIFIC ACCESSORIES.	LOGICAL INPUT/OUTPUT
GND	6	ZERO VOLT	SIGNAL GROUND
SCLI2C	7	CLOCK SIGNAL RESERVED FOR SAGEM SPECIFIC ACCESSORIES.	OPEN DRAIN INPUT/OUTPUT
INTI2C	8	INTERRUPT SIGNAL RESERVED FOR SAGEM SPECIFIC ACCESSORIES.	LOGICAL INPUT
POLANT32	9	APPLICATION INPUT SERIAL N°2	LOGICAL INPUT

(RXD2)			
RXDG	10	SERIAL DATA TO BE TRANSMITTED.	LOGICAL INPUT
TXDG	11	SERIAL DATA RECEIVED.	LOGICAL OUTPUT

SYMBOL	PIN CONNECTOR No.	SIGNAL FUNCTION	NATURE E/S, AI; Ana
DIN32	12	RESET	LOGICAL INPUT
ITDATA	13	Interruption signal keep for SAGEM accessories.	LOGICAL INPUT
GND	14	ZERO VOLT.	SIGNAL GROUND
BFRXP	15	Audio frequency signal received (ϕ 0).	ANALOG OUTPUT
BFRXN	16	Complementary output to BFRXP (ϕ 180).	ANALOG OUTPUT
BFTXN	17	AUDIO FREQUENCY SIGNAL TO BE TRANSMITTED ϕ 180. Complementary input to BFTXP.	ANALOG INPUT
BFTXP	18	AUDIO FREQUENCY SIGNAL TO BE TRANSMITTED ϕ 0. Acoustic L.F. signal to be transmitted.	ANALOG INPUT

2.4 IDENTIFICATION

All phones are identified with an identification label stucked on the antenna.

2.4.1 Illustration

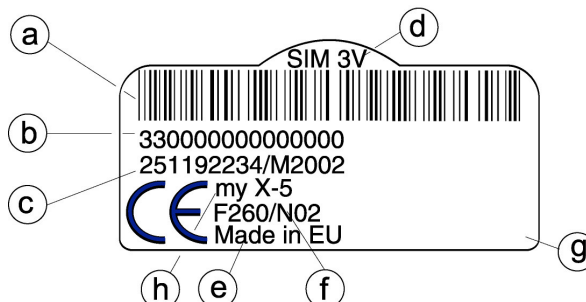

2.4.2 Description

- a : IMEI (bar code),
- b : IMEI (15 characters)
- c : Reference of product / aesthetic used .
- d : Sim card Indication (Sim 3V...),
- e : Production area Indication,
- f : Date code + Production level,
 Ex. F260/02 = (F) fabrication area (F : Fougères), (260) day of year, (02) last digit of year (02→2002).
- g : Logo and agreement.
- h : Product designation

2.4.3 Description after repair

A new sticker is positioning by Repairing Centre on the antenna :



This extra line will appear if the mobile has already been repaired.

- **CRA XXX** ⇒ N° of CRA,
- **260/02** ⇒ Date of repair: (260) repairing day, (02) last digit of year (02→2002).

2.5 PHONE BLOCK DIAGRAM

2.5.1 myX-3 & myX-5 block diagram

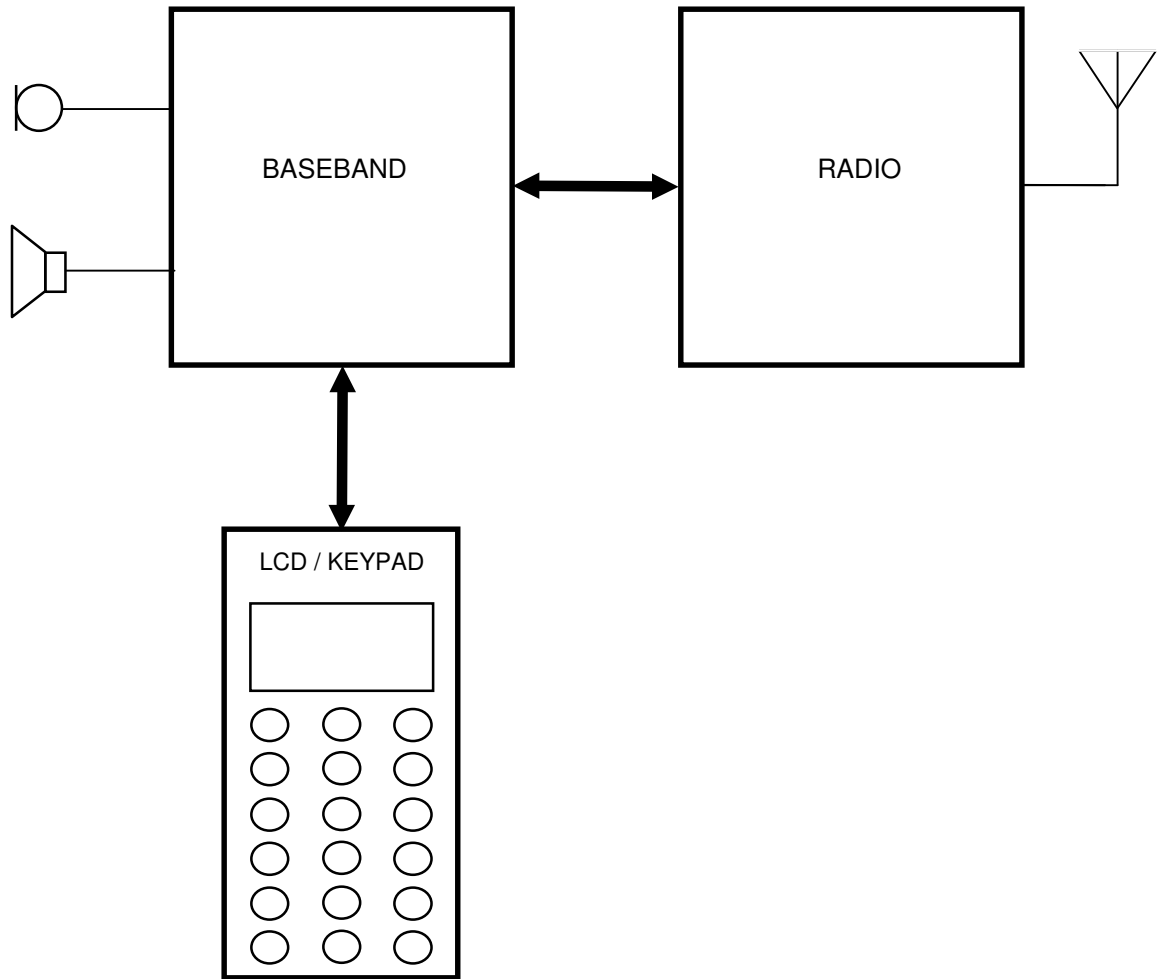

2.5.2 Standards and environment

The phone complies with the following standards.

- GSM GT01 V4.4.0
- EN 301 489-1 / EN 301 489-7
- EN 60950 , 73/23/CEE

2.6 EQUIPEMENTS

The description and operation of SAGEM myX-3 & myX-5 are given in the "User's handbook" supplied with the handset. This chapter only describes equipment that operates with the myX-3 & myX-5 handset .

2.6.1 Battery packs

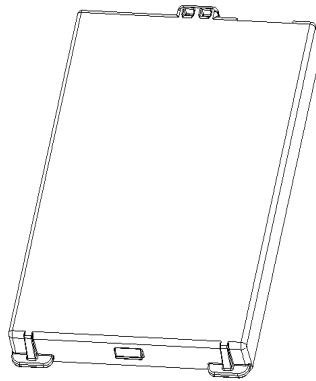

Over view

2.6.1.1 Characteristics

Type	Technology	Weight	Voltage capacity
L720	Li-Ion	21 g	3,6 V / 720 mA/H

2.6.1.2 Description

Li-ion type batteries are used. They are rechargeable using:

- mains power supply modules,
- 12 V / 24 V, cigar lighter chargers,
- car handsfree kits (compact and comfort),
- Power supply data.

Batteries caution use:

- Store the batteries in a dry and cool place (excessive cold and heat damage the batteries reliability).
- They must never be stored in bulk, even the rejects, to avoid any short circuits.
- Do not dismantle the battery packs. (Li-Ion regulations).
- Only use original mains power supply module.

2.6.1.3 Charging time

The following table shows typical charging times for different batteries.

Battery	500 mA travel chargers	AC* and K** chargers	"Simple" unregulated chargers 230 V Nom. (110 V Nom.)	
			230 V (110 V)	254 V (121 V)
	94 V à 254 V			
L720	2h30	2 h	4h30	3h20

* : cigar lighter chargers (12 V et 24 V)

** : car handsfree kits (Values screen off).

2.6.2 Mains modules

2.6.2.1 Description

These mains power supply modules accept large dynamic variations in the power supply network. They are available for a number of connector types:

- E.U,
- United Kingdom
- United States,
- Australia.

2.6.2.2 Travel mains modules

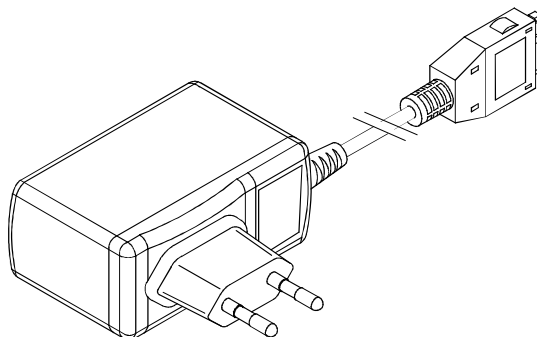

Designation	Weight (g)	Vol (cm ³)	Primary voltage
<i>UNREGULATED TRAVEL MAINS POWER SUPPLY MODULES 6.5 V. 500 mA.</i>			
TRAVEL 500 mA. EC	100	75	110/230 V
TRAVEL 500 mA. UK	110	90	110/230 V
TRAVEL 500 mA. US	125	65	110/230 V

TRAVEL 500 mA. AUS	100	75	110/230 V
--------------------	-----	----	-----------

2.6.2.3 Mains modules

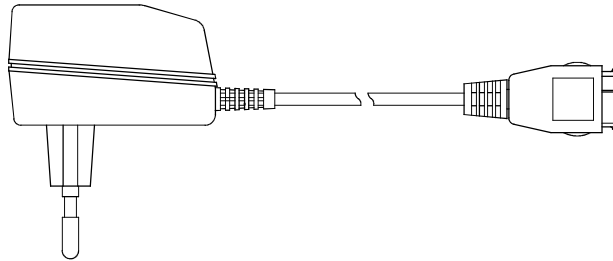

Reference	Weight (g)	Vol (cm ³)	Primary voltage
<i>SIMPLE UNREGULATED MAINS POWER SUPPLY MODULES 1.5 V. 300 mA.</i>			
EC MAINS MODULE	180	85	230 V
UK MAINS MODULE	180	120	230 V
US MAINS MODULE	210	105	110 V
AUS MAINS MODULE	190	105	230 V

CHAPTER 3 - SYMPTOMS

3.1 GENERAL

After you have received the **customer return sheet** ([Proc Sheet 3 02](#)), carry out the troubleshooting procedure.

This chapter will help you to identify the defective element(s), using the troubleshooting table.

It contains flow charts broken down by fault type. Each flow chart describes the procedure to be followed and contains cross references to tests or maintenance.

The conclusion of each troubleshooting procedure is :

- Return to SAGEM =The Return to the SAGEM centre can concern either the card, or the radiotelephone according to instructions given to the Centres of repair.
- Delivery to the customer

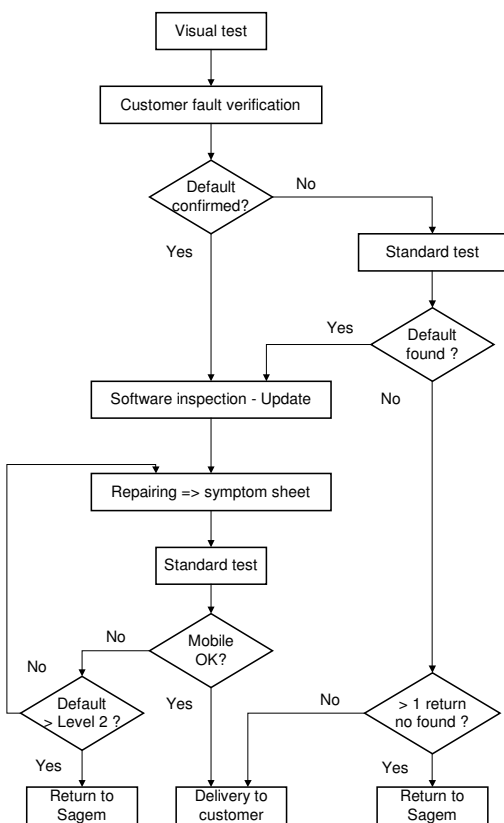

Visual test :

- Glass state
- Keypad state (elastomer, inscription)
- Connector state (SMK, battery, SIM)
- Plug and position of battery
- SIM card position
- Oxidation

Standard test :

- Display test : Hot Line menu
- Contrast control (for myX-5 only)
- All keypad keys test (check bips keys)
- Audio and radio test
- Battery charge test
- Consumption of mobile in off state
- Vibrating device test : Hot Line menu
- Charger test

Software inspection :

For all mobiles to repair, the checking by OMM is

These flow charts should be followed in full. After a reference to a removal/replacement sheet or to a test to be carried out, you should return to the initial flow chart and continue the search until reaching a final conclusion.

3.2 SHORT LOOP PROCESS

VERSION : 1.0

1. Initialization

From the communication by Sagem and the reception of the concerned products by the short lopp process, the Repair Centre shall comply with the above procedure. The application of the Short loop process will end when received the authorization of repairing given by Sagem.

2. Administrative checks to be done by the Repair Centre

- Authorization from Sagem for treating the reference received (Part number)
- Process to be applied : short loop process or normal process (DTS, Normal, etc...). The Repair Centre shall check if the product received has to be treated according to the short loop process.
- Controls on the warranty conditions and DOA conditions (if the Repair Centre is authorized) communicated by Sagem.

3. Tests and controls :

- Checks if there are no external shocks or oxidation marks (the covers shall be dismantled in case of exchangeable covers)
- Checks and confirmation of the defect (real call with SIM, functional test keypad , display, vibrating device, etc...)
- Check the concordance between the defect declared by the end-user and the defect observed
- Call back of the end-user or dealer (as far as possible) either in case of misunderstanding of the defect declared by the end-user or in case of the non observation of the defect. (see the appendix "Additional information about the No Fault Found –NFF- " at the end of this document allowing according to the case to understand the return of the product)

If any doubts occurred concerning out of warranty products received, the Repair Centre shall send to Sagem Montauban (with knowledge to the Area Manager and Support Engineer) the photo of the defect.

N.B :

- The handsets shall not be dismantled (by using screwdrivers) except previous request from Sagem.

- The Repair Centre will not make any Repair (such as spare parts exchange or software upgrade) except previous communication of Sagem. The exchange of handsets or accessories are the only intervention authorized.

4. Exchange by the Repair Centre

- The Repair Centre will use the products delivered for swap to the Repair Centre for exchanging the products to the end-users (except particular process defined by Sagem).
- The under- warranty handsets and accessories received shall be exchanged to the end-user.
- The under- warranty handsets and accessories declared No Fault Found (NFF) shall be exchanged to the end-users except previous communication of Sagem.
- The Out of warranty handsets and accessories (oxidation, shocks, ...) will be repaired by the Repair Centre after acceptance by the customer of an estimate according to the Sagem out of warranty repair prices communicated.
- **The under- warranty and out of warranty handsets shall be sent to Sagem Montauban.**
- In the frame of the Short loop process, there is no level 1 (L1) intervention

5. Reports

An exchange of an handset and its accessories shall be codified Level 3 (L3)

An accessory exchange shall be codified Level 0 (L0).

The Repair Centre shall capture all the information required for issuing and sending the Repair Reports and Status reports according to the Contractual frequency defined. The Reports shall includes the products treated by the Repair Centre under- warranty or out of warranty.

6. Procedure

From the beginning date of the Short loop process application and **minimum each week, the Repair Centre shall ship the products (handsets and accessories) to Sagem Montauban.**

61. Handsets :

- MRA Procedure for the after-Sales products (one MRA number for the products concerned by the short loop).
- MRA Procedure for DOA products (one MRA DOA number for the products concerned by the short loop) if the Repair Centre is authorized to treat the DOA products.

The MRA request shall be sent to Sagem Montauban (with knowledge to the Area Manager and Support Engineer).

The shipment of products to Sagem Montauban shall comply with the MRA procedure. Furthermore each products shall be sent with the Return Product Sheet filled in indicating the defect declared by the end-user and the defect observed by the Repair Centre (Sagem Defect codes).

The NFF products sent to Sagem Montauban shall be identified by using separate package. Furthermore this products shall be sent with the complete description of the defect declared by the end-user (not codified).

The accessories received by the Repair Centre shall be sent to Sagem Montauban sent back attached with the handset (not connected to the handset).

62. Accessories :

For the accessories received without the handsets, the procedure is the following:

Accessories return procedure to Sagem Montauban to be used. The Repair Centre shall indicate on the parcel Accessories + model (ex : myX-6) for the accessories received in the Repair Centre without the handsets.

7. Sagem Montauban

Sagem Montauban will ship back to the Repair Centre the same quantity of handsets and accessories as the quantity received.

Appendix

**ADDITIONAL INFORMATION
ABOUT THE NO FAULT FOUND**

In any case: Ask to the end-user the frequency of the defect and the circumstances of its apparition (during an incoming or out-going call, while playing, while downloading, etc.). Try to answer the questions: Where? When? How?

- If the customer complains about a “**Power supply / charging**” failure : (shutting down of the mobile, problem of booting, etc.);
 - During which operation ? In which circumstances ?

What is the state of the battery and the charger before shipment to the repair centre ?

- If the mobile shuts down by itself, must he enter his code pin, adjust the date and the hour when rebooting the phone?

- If the customer complains about a communication problem:
 - What are his residence zone and the reception level of the mobile (Number of receipt bar);
 - What is the state of the battery when the defect appears?
 - In case of loss of communication :
 - With or without total extinction of the mobile?
 - Does the loss of communication occur always in the same place and with the same person?
 - Does the loss of communication occur while browsing in the menus, during the communication, or during playing or downloading?

- If the customer complains about a problem of blockage of key of the keyboard:
 - In which circumstances does the problem occur?
 - Did he activate the keypad locking ?
 - Did he change or remove the upper cover ?
 - Which are the non functioning keys ?

3.3 LIST OF REPORTED DEFECTS

The following is a list of defects that may be reported :

Code	Indicated fault	Procedure
A0	Display malfunction	Symp Sheet 04
A1	No power up	Proc Sheet 1 11 or 3 01
A2	No display up	Symp Sheet 04
A3	Freezes up	Proc Sheet 1 11 or 3 01
A4	Back lights problem	Proc Sheet 1 11 or 3 01
A5	Broken LCD	Symp Sheet 04
A6	Line or digit missing	Symp Sheet 04
B0	Power supply / no charge	Symp Sheet 01
B1	Defective battery contact	Proc Sheet 0 02
B2	Defective charger connector	Proc Sheet 1 11 or 3 01
B3	Defective power supply of the board	Proc Sheet 1 11 or 3 01
B4	Defective charge icon display	Proc Sheet 1 11 or 3 01
B5	Intermittent cut with reboot	Proc Sheet 1 11 or 3 01
B6	Intermittent cut without reboot	Proc Sheet 1 11 or 3 01
B7	Autonomy	Symp Sheet 01
B8	Electrically defective battery	Test Sheet 03
B9	Mechanical lock problem on battery	Proc Sheet 0 02
B10	Broken battery	Test Sheet 03
B11	Defective charger	Test Sheet 02
B12	Broken charger	Test Sheet 02
B13	Current consumption with phone off	Test Sheet 04
C1	Not functioning keyboard	Symp Sheet 05
C2	Lateral key problem	Symp Sheet 05
D1	Sim missing	Proc Sheet 1 11 or 3 01
D2	Other messages	Proc Sheet 1 11 or 3 01
D3	EEPROM pb	Proc Sheet 1 11 or 3 01
D4	Untuned mobile	Proc Sheet 1 11 or 3 01
D5	Hard failure	Proc Sheet 1 11 or 3 01
D6	Sim lock	Proc Sheet 1 11 or 3 01
D7	Post code	Test Sheet 01
D8	Return SAV	Proc Sheet 1 11 or 3 01

D9	Unknown battery	Test Sheet 03
----	-----------------	-------------------------------

Code	Indicated fault	Procedure
E1	Defective loudspeaker (hails)	Symp Sheet 08
E2	Loudspeaker voice distortion	Symp Sheet 08
E3	Defective microphone	Symp Sheet 08
E4	Microphone voice distortion	Symp Sheet 08
E5	Vibrating device malfunction	Symp Sheet 07
E6	Defective audio connector	Symp Sheet 08
F1	No network localisation	Symp Sheet 02
F2	Intermittent calls drop	Symp Sheet 02
F3	Network temporary drop	Proc Sheet 1 11 or 3 01
F4	Test radio no ok	Proc Sheet 1 11 or 3 01
F5	Outgoing call failure	Symp Sheet 02
F6	Incoming call failure	Symp Sheet 02
G1	Broken or damaged glass	Proc Sheet 0 01
G2	Broken or damaged cover	Proc Sheet 0 01 /0 03
G5	Broken or damaged keyboard	Proc Sheet 0 04
H1	DATA PROBLEM (SMS, EMS, SMS,GPRS, WAP, DOWNLOADING GAMES, RINGING TONES, SCREEN SAVER, NO COMMUNICATION WITH A PC, POCKET PC or PALM)	Test sheet 01
H2	Video function	Proc Sheet 1 11 or 3 01
H3	INFRARED function (IRDA)	Test sheet 01
I1	Oxidation marks	Proc Sheet 1 11 or 3 01
I2	FM function	Proc Sheet 1 11 or 3 01
I3	Monetic function	Proc Sheet 1 11 or 3 01
I4	Broken or damaged accessory	Proc Sheet 1 11 or 3 01
I5	Defective SIM connector	Proc Sheet 1 11 or 3 01
I6	Malfunction of the menu	Test sheet 01
I7	Lack function in the menu	Test sheet 01
I8	No fault found	Symp sheet 03

3.4 ERROR MESSAGES DURING START UP

<i>Message</i>	<i>Meaning</i>	<i>Procedure</i>
WARNING UNTUNED RADIO	Invalid EEPROM field (SAGEM)	SAGEM factory return
PB IMEI	Consistency problem at IMEI level	SAGEM factory return
SIM MISSING	SIM card missing or badly inserted	Insert the SIM card
IMEI ERROR	Consistency problem at IMEI level	SAGEM factory return
ERRONEOUS NUMBER	Invalid number (after reception of a network error code)	SAGEM factory return
UNTUNED	Mobile not configured	SAGEM factory return
UNKNOWN BATTERY	Battery not recognised by the mobile	Replace the battery
HARDWARE FAILURE MOBILE BLOQUED	Exceeding numbers of capture of unlock SIM code.	Out of Warranty
SIM BLOCKED	Three bad PIN codes have been input	Contact the operator
SIM LOCKED (with SIM)	SIM card not adapted to the operator	Replace the SIM card
SIM LOCKED (without SIM)	Attempt of corruption (EEPROM fields)	Out of Warranty
BATTERY TOO LOW	Battery state	Replace the battery
PROTECT SIM	Integrity violation of phone	SAGEM factory return
BEWARE MOBILE UNREGULATED	Mobile unregulated	SAGEM factory return

3.5 OTHER ERROR MESSAGES

<i>Message</i>	<i>Meaning</i>
"LINE INCIDENT"	Fax & PC link type "Problems"
"FULL MEMORY"	Fax & PC link type "Problems"
"CLEARING REJECTED"	Fax & PC link type "Problems"
"CHECK CONNECTION"	Fax & PC link type "Problems"
"NOT CONSULTED DOCUMENT"	Fax & PC link type "Problems"
"DEVICE PROBLEM"	Fax & PC link type "Problems"
"VERIFY APPLICATION"	Fax & PC link type "Problems"
"BUSY"	"Problems" related to the network and Communications
"K.PAD LOCKED PRESS *V"	Keypad locked
"OPTION NOT AVAILABLE"	Menu not available for this product version
"PROG.KEY NOT VALID"	Input "Problems"
"ERROR!!"	Calculation error with the calculator (division by zero)
"NOT REACHABLE"	Call forwarding if the mobile is not reachable
"NOT AVAIL."	Not available
"SIM LOCKED"	"Problems" related to the SIM card (protected software)

"PIN ERROR"	" PIN input problems "
"PIN2 BLOCKED"	Following input errors
"PUK ERROR"	Following input errors

<i>Message</i>	<i>Meaning</i>
"PUK2 BLOCKED"	Following input errors
"CODE ERROR"	The phone code input for locking the mobile is incorrect
"NOT AVAIL."	Service not implemented in the network
"TRY AGAIN"	Following a network problem
"NETWORK BUSY"	"Problems" related to the network and Communications
"WAIT"	"Problems" related to the network and Communications
"UNBLOCK?"	"Problems" related to the SIM card
"MEMO REC. CUT"	Save during storage in the answering machine truncated due to lack of space
"FUNCTION NOT ALLOWED"	Prohibited function requested
"NOT FOUND"	Unsuccessful search (on directory, etc.)
"BUSY"	"Problems" related to the network and Communications
"REJECTED"	The requested operation was refused by the network
"EMPTY"	Empty (note pad, memo, etc.)
"NOT IN GROUP"	Error display following an error code returned from the network (CUG menus)
"CREDIT END"	"Credit end" information (paying call prohibited)
"CREDIT TOO LOW"	"Credit too low" information (CUG menus)
"NO AUTHORIZED ACTION DURING A WAP CALL"	Not available action during a wap call
"NOT CONFIGURED ACCESS"	Selection of a not configured provider
"UNKNOWN ACCESS"	Selection of a not fully configured provider
"UNKNOWN CALL IN PROGRESS"	Selection of a provider during a call in progress
"NO RESPONSE OF THE SERVER"	" Problems" related to the server
" NO RESPONSE OF THE NETWORK"	"Problems" related to the network and Communications
"NOT AVAILABLE NETWORK"	"Problems" related to the network and Communications
"TOO LONG URL ADDRESS"	The address typed is too long

3.6 LIST OF OBSERVED DEFECTS

A SAGEM code is assigned to each confirmed defect. This code should be entered on [Proc Sheet 3 01](#), **SAGEM Factory Return**, if the phone to be repaired is returned to SAGEM (**see chapter 5**).

SYMPTOM SHEETS

 SAGEM	ENDURANCE, BATTERY, CHARGER PROBLEM	Symp Sheet 01
myX-3 & myX-5		1/1

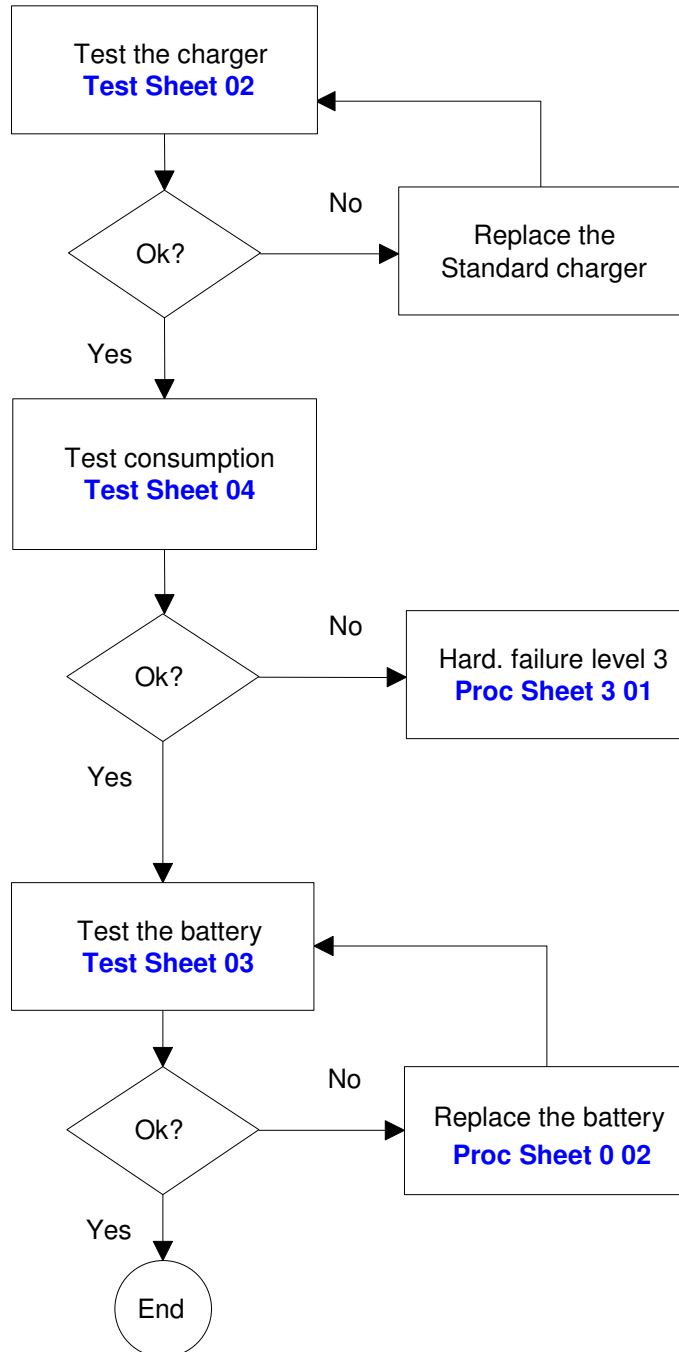

 SAGEM	COMMUNICATION PROBLEM	Symp Sheet 02
myX-3 & myX-5		1/1

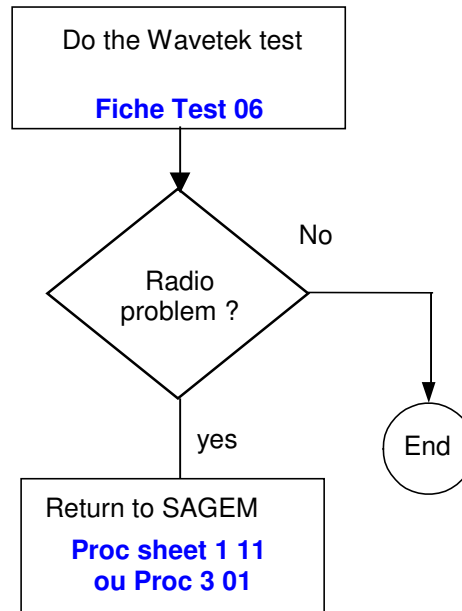

 SAGEM	NO FAULT GIVEN	Symp Sheet 03
myX-3 & myX-5	(Expertise of the phone)	1/1

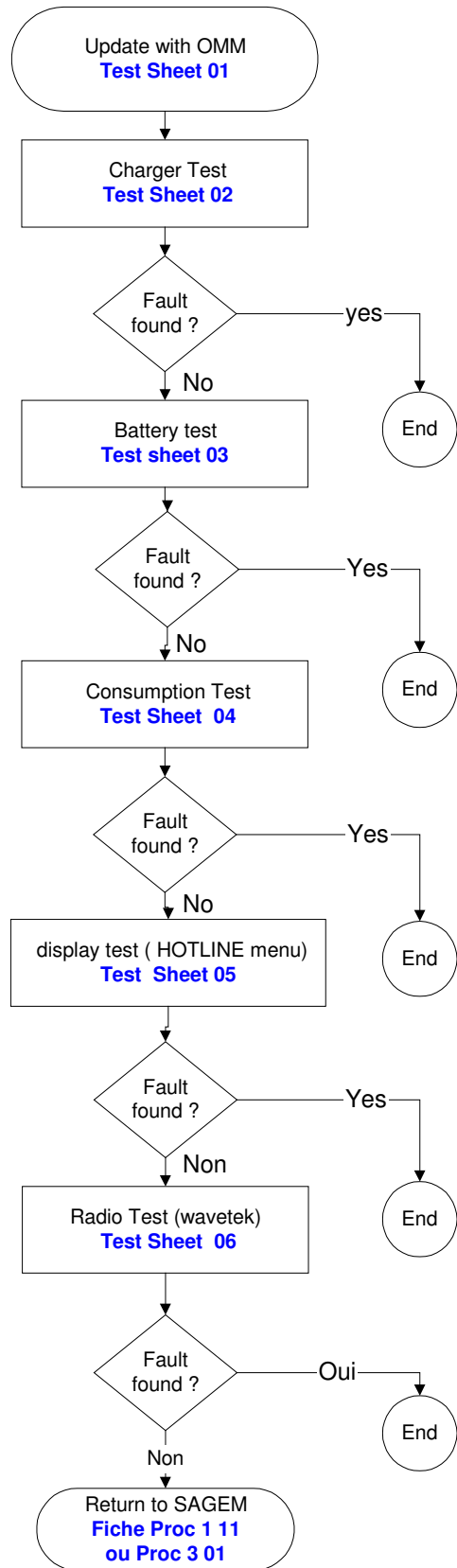

 SAGEM	DISPLAY PROBLEM	Symp Sheet 04
myX-3 & myX-5		1/1

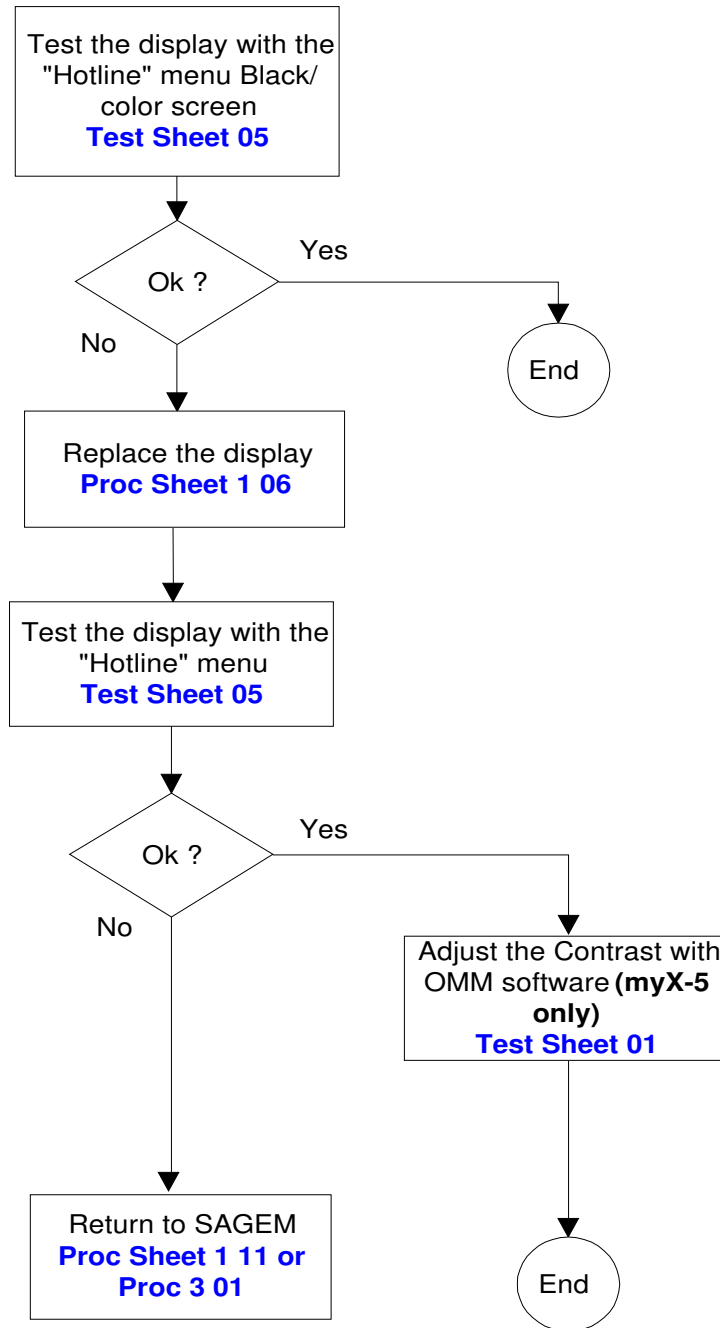

 SAGEM	KEYPAD PROBLEM	Symp Sheet 05
myX-3 & myX-5		1/1

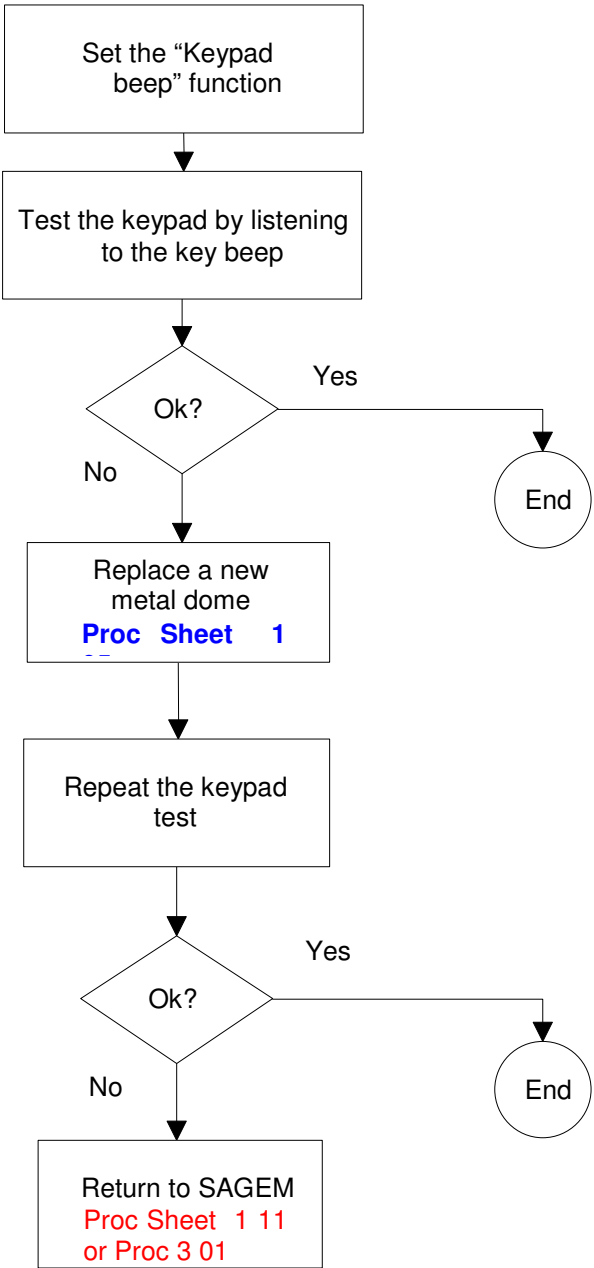

 SAGEM	RING TONES PROBLEM	Symp Sheet 06
myX-3 & myX-5		1/1

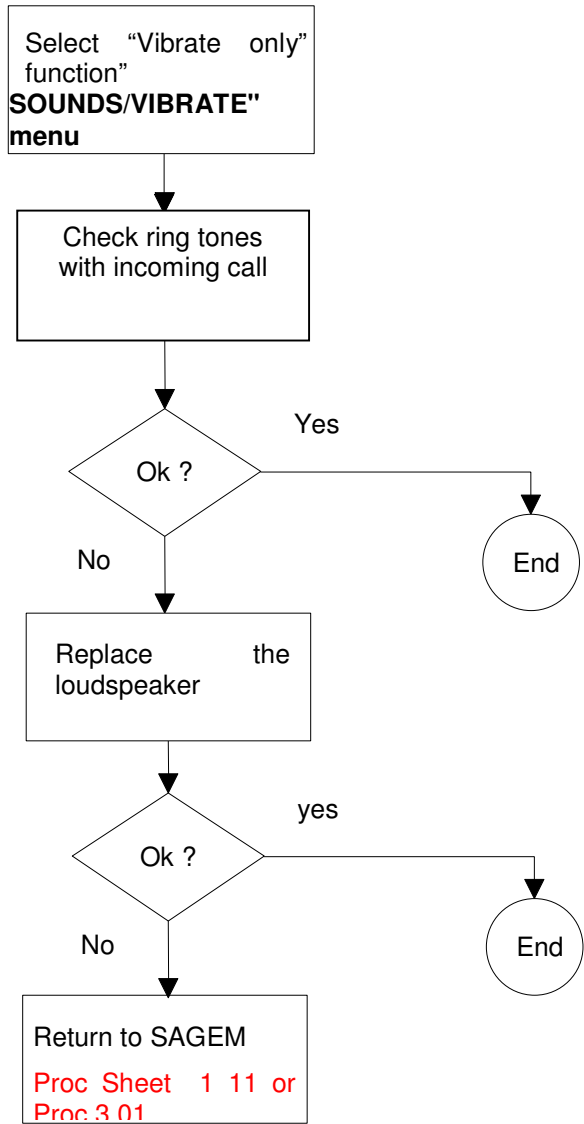

 SAGEM	VIBRATING DEVICE	Symp Sheet 07
myX-3 & myX-5		1/1

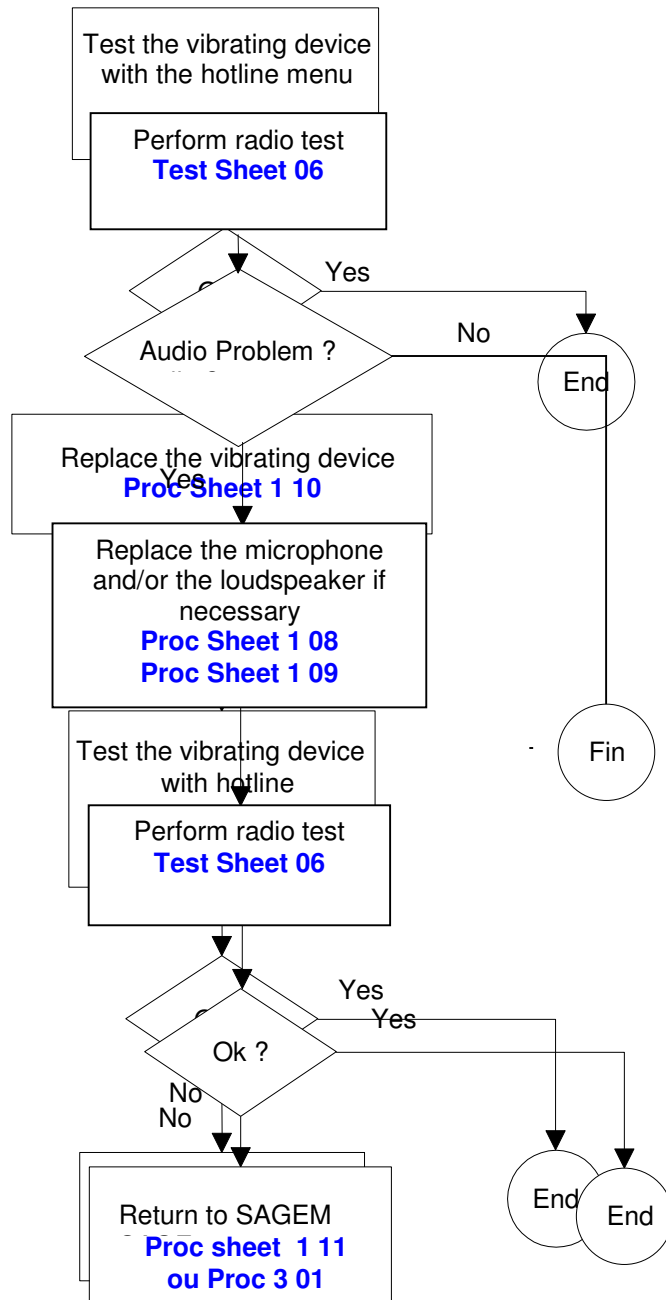

CHAPTER 4 - TESTS AND CHECKS

4.1 ABOUT TESTS

Tests and checks are made after the troubleshooting procedures (chapter 3) and before the maintenance procedures (chapter 5).

They are broken down into modules and are sorted by types of confirmed faults. The user must be equipped with special test tools in order to carry out the tests.

4.2 TEST TOOLS

The references of SAGEM tools, listed hereafter, are given in Appendix 1 : Composition table.

The following test tools are necessary :

- a PC type computer,
- the OMM maintenance software for the myX-3 & myX-5
- the **ARC downloading kit**, including the test case provided with:
 - the data cable (to PC),
 - the "SMK" cable,
 - the mains power supply module.
- the **radio test bench**, provided with:
 - SIM card of test.
 - myX-3 & myX-5 radio interface
 - Adjustable regulate power supply 0-15V / 4A
 - Wavetek 4107
- **CADEX C7000 / C7200 / ASTRATEK** with myX-3 & myX-5 adapter
 - Charger test kit
 - Ammeter interface myX-3 or myX-5
 - Voltmeter (minimum impedance : 20 K Ω per Volt in DC)
 - Ammeter
- an **IMEI labels printing station**, including :
 - Printer,
 - Roll of labels,
 - Connecting cable for PC (parallel printer cable),
 - Printing software,
 - Labels customisation disk.

4.3 INSTALLING ON A WORKSTATION

4.3.1 Minimum required configuration

The minimum configuration of the workstation is :

- Processor 1Ghz,
- 128 Mbytes of RAM,
- Windows (S.R2), Windows NT (SP 4), Windows 2000, Windows XP,
- 2.1 Gbytes hard disk (1 Gbytes available),
- 1 parallel port and 2 serials ports.
- network card, sound card.
- 1 internet access,

Attention : **If you move the dongles from one station to another, they will be locked and made unusable (return to factory).**

4.3.2 Installing the ARC downloading kit

The ARC downloading kit interfaces the OMM software with the phone to be repaired.

- Connect the 9-pin SUB-D connector to the PC serial port (COM1).
- Connect the power supply module to the mains power outlet.
- Connect the phone to be repaired to the SMK connector.

4.3.3 OMM functions

The OMM maintenance software can :

- Download new software if needed
- Configure default values and checks them.
- Unblocked the " POST CODE "
- Delete the customer directory and SMS
- Print identification labels.
- Make a electronic board exchange
- Adjust the display contrast
- Read the STD
- Select a test sequence

The procedures for using these functions are described in [TEST Sheet 01](#).

TEST SHEET

 SAGEM	TEST AND CHECK BY OMM	Test Sheet 01 1/1
myX-3 & myX-5		

To run the functions described below, run the OMM application from the desktop icon.

Notice: The active connection with OMM (via the serial port), validate in itself the data functionality of the handset.

DOWNLOADING : Download the latest software

1. Click on the READ popup menu and then on INFORMATIONS.
2. Follow the procedures on the screen.
3. Make sure that the mobile phone is not in the sleep mode (press the Start key)

CONFIGURATION : Configure and check default values

1. Click on the CONFIGURE popup menu and then VERIFY (Verfab).
2. Follow the procedures on the screen.

CONFIGURATION : Release the " POST CODE"

3. Click on the CONFIGURE popup menu and then on RELEASE
4. Follow the procedures on the screen.

CUSTOMER DATA : Delete the customer directory and SMS

5. Click on the CUSTOMER DATA popup menu and then ERASE DIRECTORY OR ERASE SMS.
6. Follow the procedures on the screen.

Note : There is possibility to save the directory when the ARC signed a confidential agreement.

 SAGEM	TEST AND CHECK BY OMM	Test Sheet 01 1/1
myX-3 & myX-5		

LABEL : Print identification labels

1. Click on the on LABEL popup menu and then PRINT LABEL .
2. Follow the procedures on the screen

AUDIO : Audio parameters setting

Click on the AUDIO popup menu
 Follow the procedures on the screen

OMM SEQUENCE : Series of the different functions under OMM (sequence of tests)

1. Click on OMM SEQUENCE popup menu.
2. Select the different functions you want to carry out then click on LAUNCH button.

Adjust the display contrast

Function under development.

 SAGEM	TEST AND CHECK BY OMM	Test Sheet 01 1/1
myX-3 & myX-5		

SWAP : Electronic board Configuration

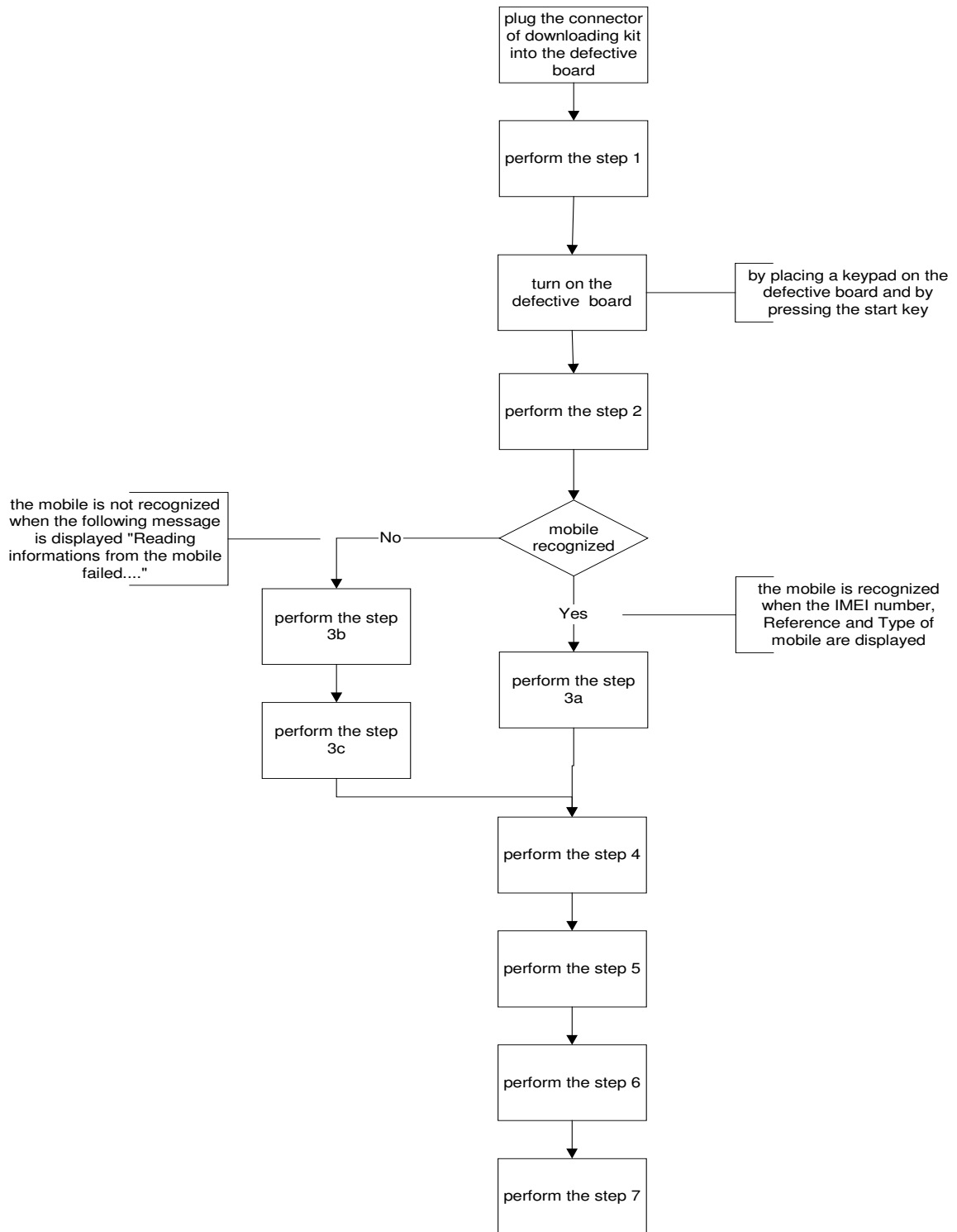

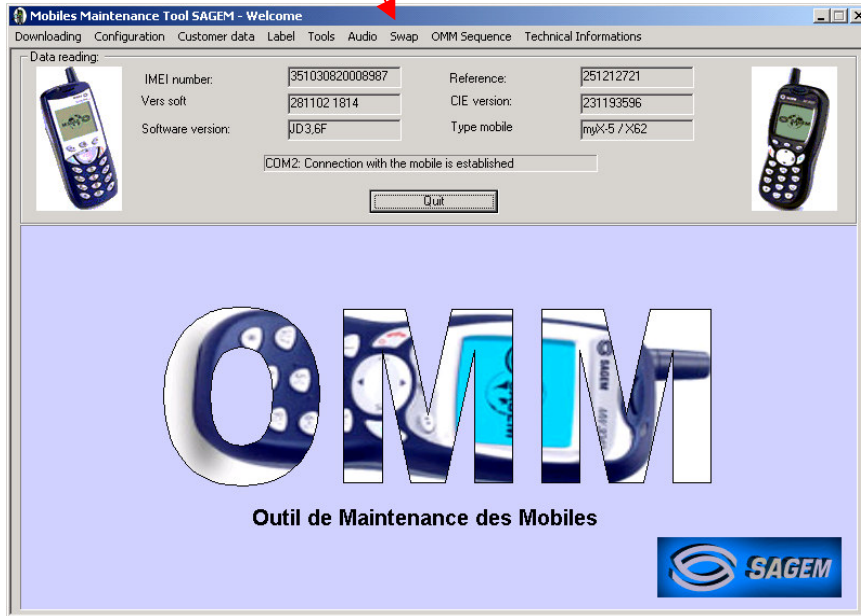

	TEST AND CHECK BY OMM	Test Sheet 01 1/1
myX-3 & myX-5		

Step 1
OMM Front page
Click on the « SWAP » menu.

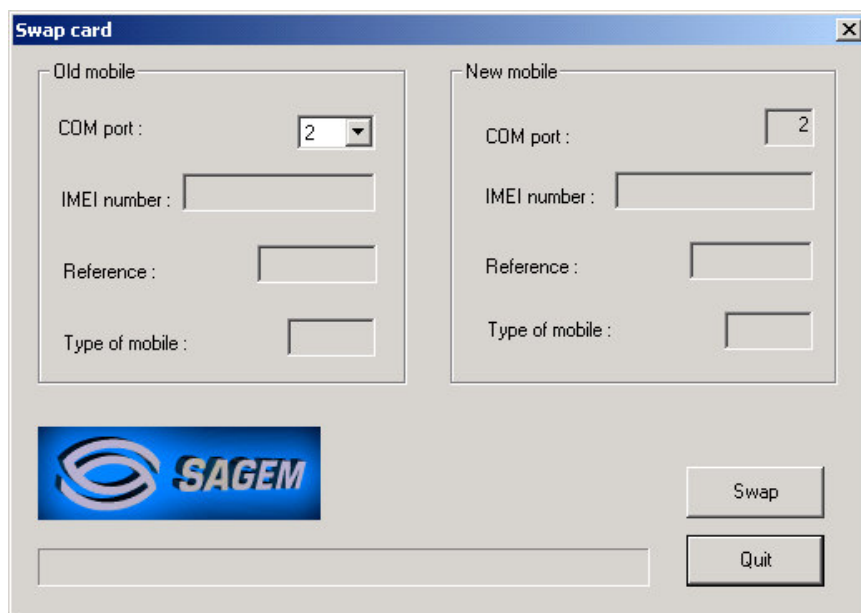

The following screen appears :



	TEST AND CHECK BY OMM	Test Sheet 01 1/1
myX-3 & myX-5		

Step 2

Please click on « **SWAP** » button to launch the swap board sequence

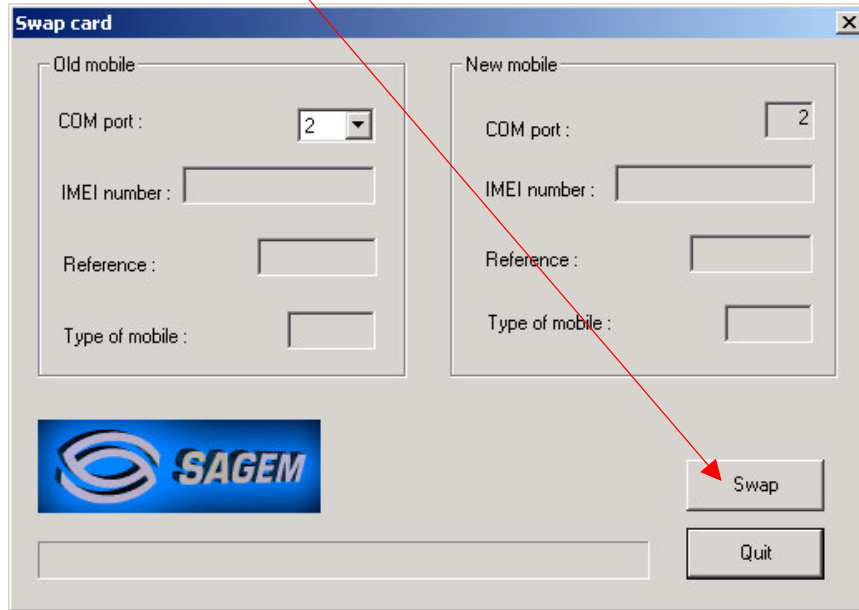

Step 3a

The following screen appears : the mobile is recognized.

Please follow the instructions pop up

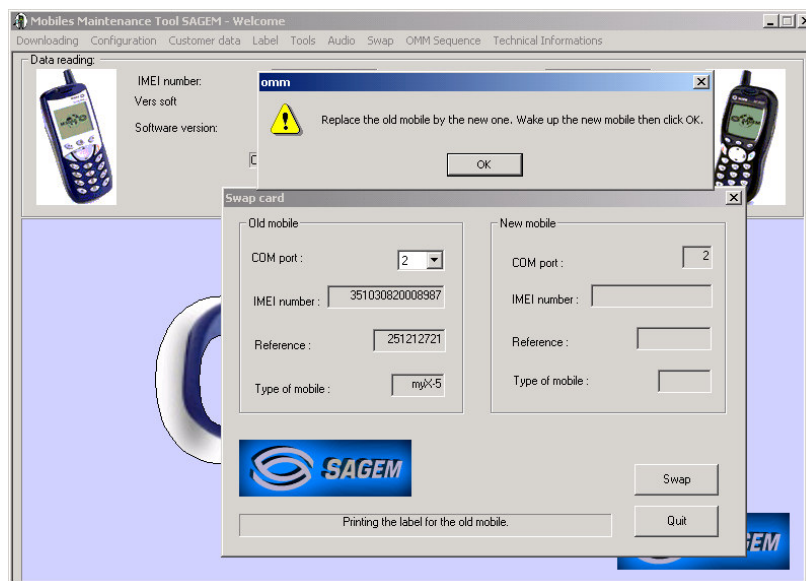

	TEST AND CHECK BY OMM	Test Sheet 01 1/1
myX-3 & myX-5		

Step 3b

The mobile is not recognized,

Select « IGNORE » and please follow the instruction according to the functional state of the mobile

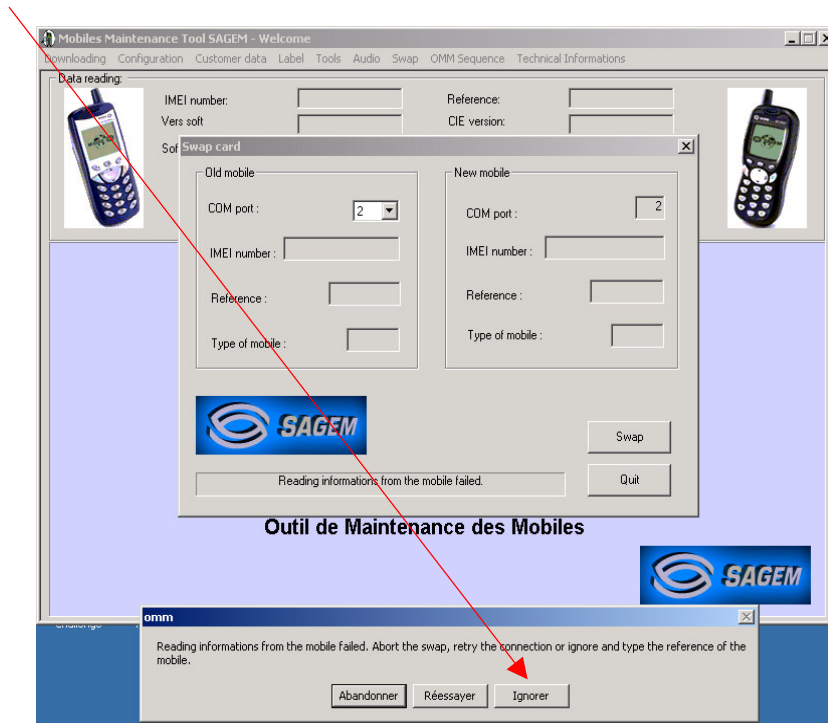

Step 3c

The following screen appears, you must fill in the empty blanks requested according to the information written on the production label

IMEI - Reference [X]

IMEI number :

Reference :

Type of mobile :

Mobile date code:

IMEI - Reference [X]

IMEI number :

Reference :

Type of mobile :

Mobile date code:

	TEST AND CHECK BY OMM	Test Sheet 01 1/1
myX-3 & myX-5		

Step 4

After clicking on “OK”, OMM prints the label which will be used to close the ESD bag of the defective board.

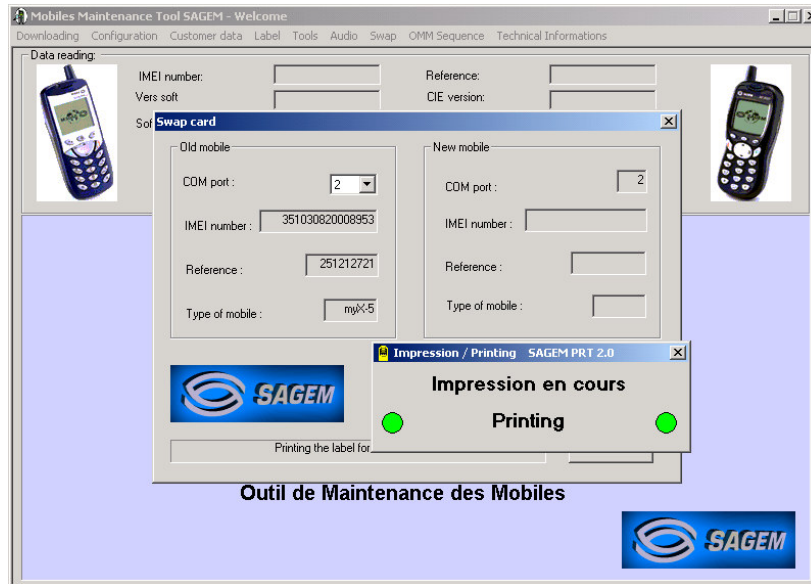

Step 5

**Then, plug the functional mobile and click on “SWAP”
The downloading is starting if the mobile need to be updated.**

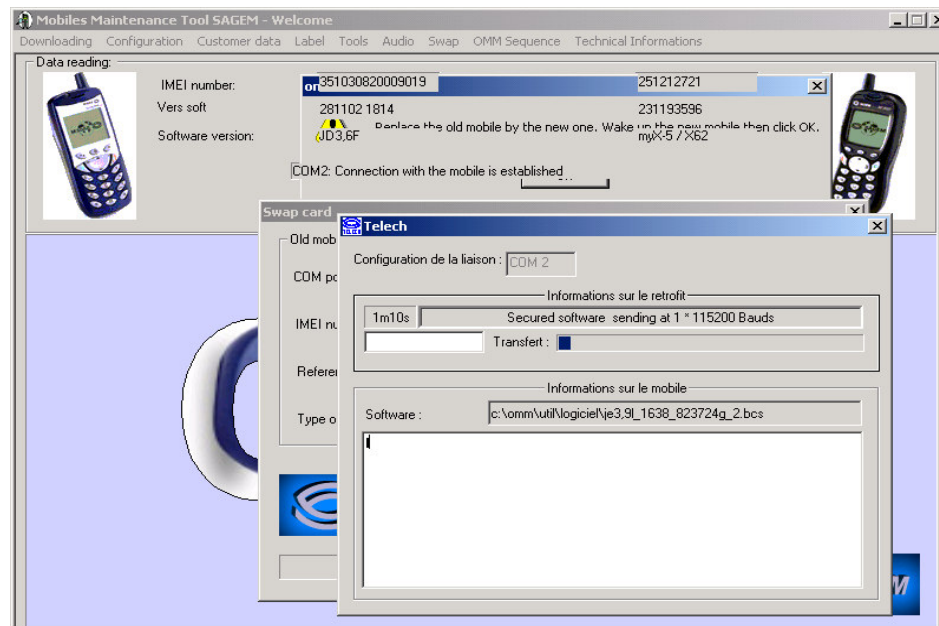

 SAGEM	TEST AND CHECK BY OMM	Test Sheet 01 1/1
myX-3 & myX-5		

Step 6

When the downloading is over, automatically the checking step starts.

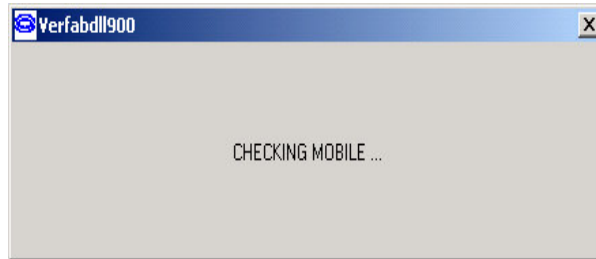

Step 7

OMM opens the following screen to print the new label : please dial the “MAKING DATE” written on the label of the defective mobile.

Then stick the new label on the functional mobile

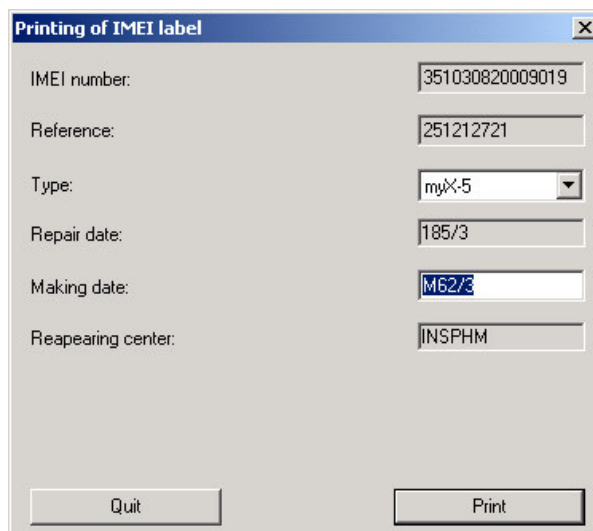

The swap board sequence is completed.

	TEST AND CHECK BY OMM	Test Sheet 01 1/1
myX-3 & myX-5		

RESULTS

When old mobile recognized, the audio parameters from the defective mobile have been sent to the functional mobile.

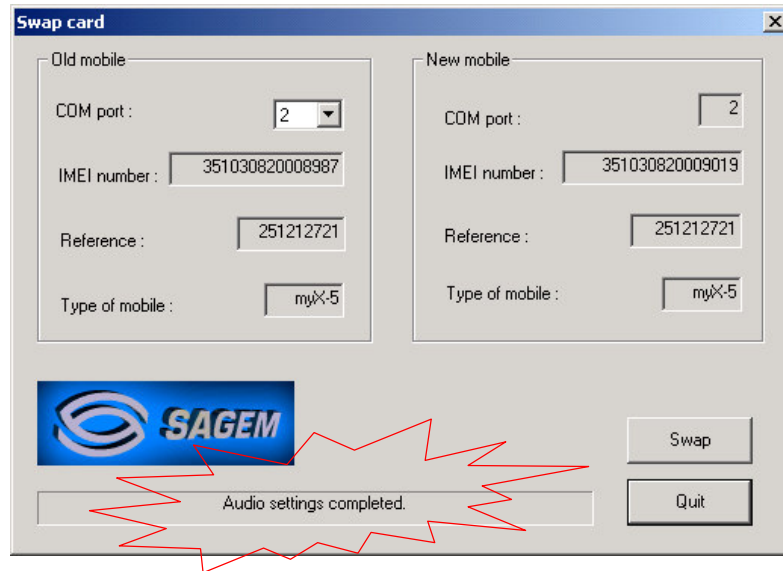

When old mobile is not recognized, the DEFAULTS audio parameters are sent to the functional mobile.



	CHARGER TEST	Test Sheet 02 1/1
myX-3 & myX-5		

Test description

This test checks the various battery chargers.

Required tools

- a voltmeter (minimum impedance 20 kΩ per Volt in DC),
- two sockets for banana connectors for connection to the voltmeter,
- a charger test kit.

Test procedure

Two terminals are used for measurements on the charger test kit

- red (+),
- black (-).

A pushbutton selects the measurement :

- at no load (released position),
- under load (pushed in position).

7. Check visually the charger connector.

8. Connect the charger to be tested to the back of the tester.

9. Connect the voltmeter using the two banana connectors.

10. Before starting any other measurement, check that the charger is correctly powered (mains voltage conform with the charger specifications).

11. Make the two measurements.

12. Check the recorded values using the following table.

Charger	At no load		Under load	
	Min.	Max.	Min.	Max.
Travel 500 mA	5,5 V	7,5 V	2 V	4 V
Simple 300 mA	9 V	15 V	1,5 V	4 V
cigar lighter	5,5 V	7,5 V	2 V	4 V

 SAGEM	CONSUMPTION TEST	Test Sheet 04 1/1
myX-3 & myX-5		

Test description

This test tests the battery consumption.

Required tools

- myX-3 Ammeter interface
- myX-5 Ammeter interface
- An Ammeter.

Test procedure

Measurement when switched off

17. Insert the mobile (switched off) onto the tool (customer phone and battery).
18. Connect the ammeter to the tool between A poles:
 - Red tool terminal on the ammeter "**COM**" or "**GND**" terminal.
 - Black tool terminal on the ammeter "**+**" terminal.

NOTE: The ammeter rating must be set to DC (DC or =), range 100 mA.

19. The value shown must be less than 1 mA.
20. Disconnect the ammeter from the tool and remove the mobile from the tool, with the battery.

Measuring the charge

21. Insert the mobile (switched off) onto the tool (customer phone and battery).
22. Connect the ammeter to the tool between A poles:
 - Black tool terminal on the ammeter "**COM**" or "**GND**" terminal.
 - Red tool terminal on the ammeter "**+**" terminal.

NOTE: The ammeter rating must be set to DC (DC or =), range 1 A.

23. Connect the customer's charger when energised (after connecting the charger to the mains power supply).
24. The recorded value must be greater than 150 mA.

NOTE: When changing the ammeter rating (manual or automatic), the mobile can be disconnected.

 SAGEM	"HOTLINE" MENU	Test Sheet 05 1/2
myX-3 & myX-5		

Access to the "HOTLINE" menu

Access to the "HOTLINE" menu is possible with a powered up mobile.

The "HOTLINE" menu is accessed by pressing on the ▾ key and then the * key.

Enter the corresponding code (bold) to choose the menu to be viewed.

To go out the "HOTLINE" menu, press successively on the C key to return at the operational screen of the mobile.

Description of the myX-3 "HOTLINE" menu

1 APPLICATION

11 VERSION : reads the installed software version and the IMEI code.

12 BATTERY : gives the value of the battery voltage.

2 PROM : Not used.

3 SIM LOCK : accesses the "SIM LOCK" menu (password required).

4 LCD TEST

41 CHECKER BOARD : carries out the checker board screen test.

42 INVERSE CHECKER BOARD

43 BLACK : displays the screen in black.

44 FOR PHOTO : displays functions on the screen to take a photo.

45 VIBRATING DEVICE : tests the vibrating device.

 SAGEM	"HOTLINE" MENU	Test Sheet 05 2/2
myX-3 & myX-5		

Description of the myX-5 "HOTLINE" menu

1 APPLICATION

- BATTERY : gives the value of the battery voltage.
- VERSION : reads the installed software version and the IMEI code.

2 PROM : Not used

3 SIM LOCK : accesses the "SIM LOCK" menu (password required).

4 TESTS LCD

- BLACK DISPLAY : displays the screen in black.
- WHITE DISPLAY.
- RED DISPLAY
- GREEN DISPLAY
- BLUE DISPLAY
- WHITE CHECKERBOARD
- PHOTO DISPLAY : functions on the screen to showing a picture.
- VIBRATE: tests the vibrating device.

NOTE : The "HOTLINE" menu is only accessible with a valid SIM card.

Test description

This test tests myX-3 & myX-5 phones during a call.

Required tools

- a Wavetek
- a radio interface myX-3 & myX-5.
- an adjustable regulate power supply 0-15V / 4A

Installation

RF test

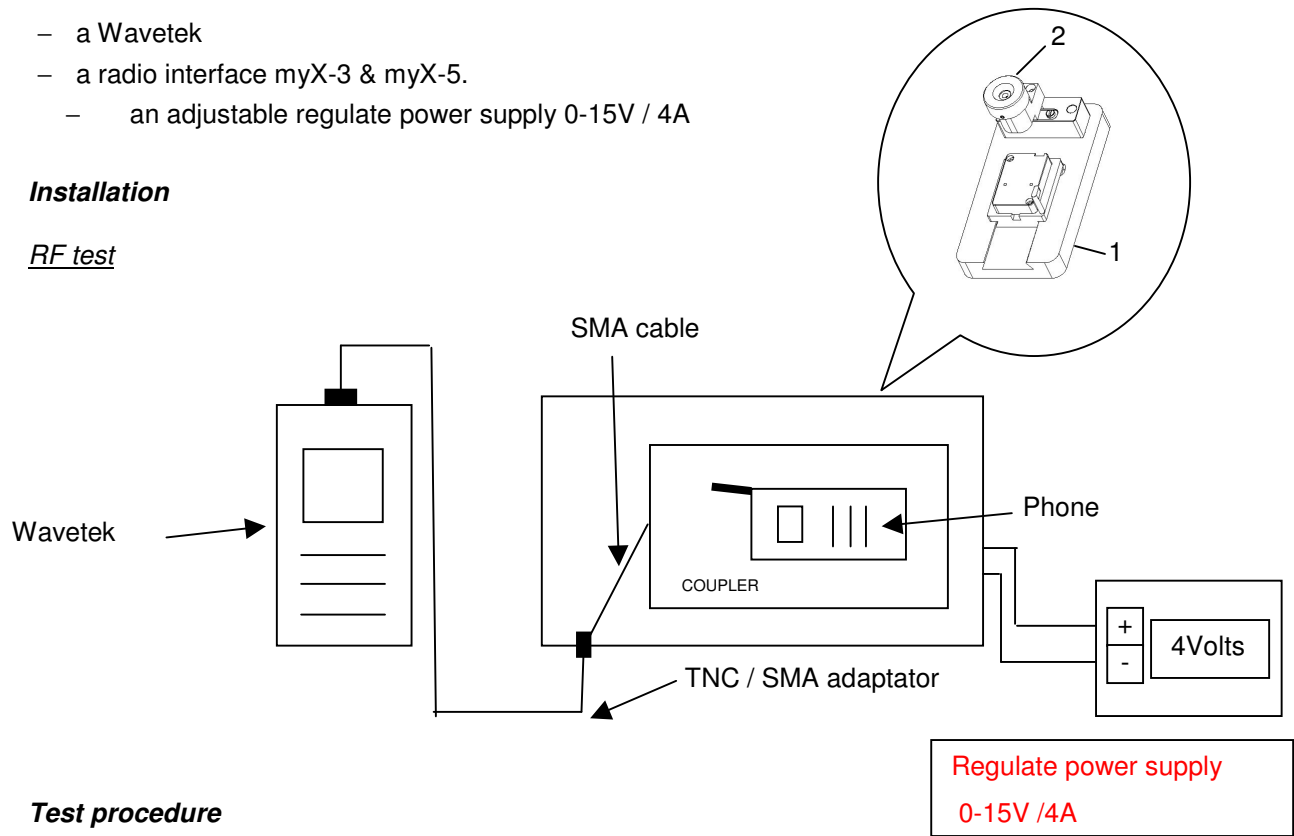

Test procedure

25. Position the myX-3 or myX-5 module on the radio interface (1) (provided with a SIM test card)
26. Press and lock the button (2) , press the start key
27. Switch the Wavetek on and press on "AUTOTEST".
28. Choose the corresponding program using the "UP" et "DOWN" arrows.
 - Mobile :**myX-3 or myX-5**,
 - Frequency range : **GSM, DCS or GSM/DCS**,
 - Coupling type : **CABLE**.
29. Press on "ENTER" and wait until the end of the calibration.
Follow the instructions shown on the Wavetek.

CHAPTER 5 - MAINTENANCE PROCEDURES

TECHNICAL WORK LEVELS

There are four technical work levels:

- Level 0,
- Level 1,
- Level 2,
- Level 3.

Each level represents a maintenance degree that depends on which elements are to be removed.

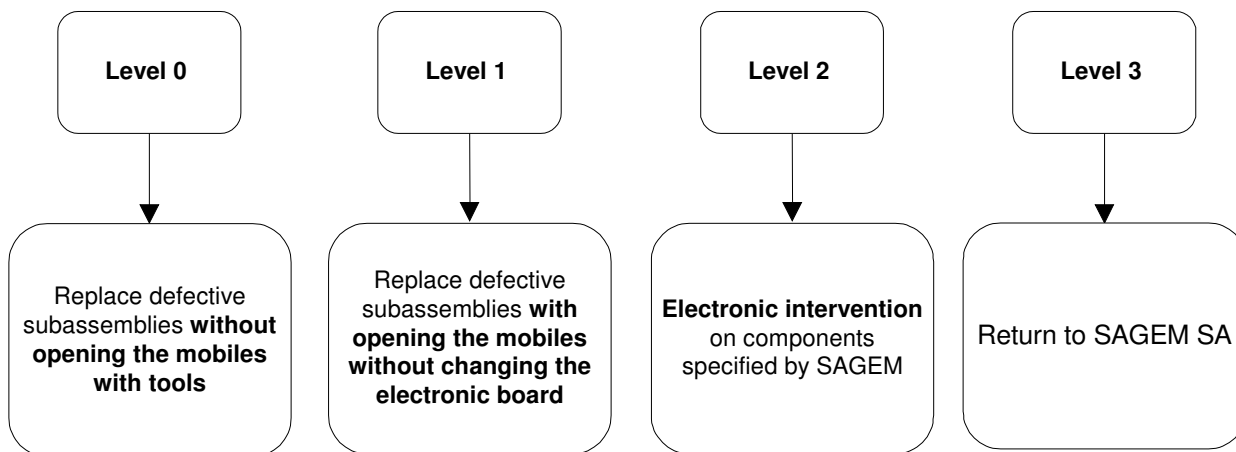

Maintenance procedure sheets are coded as follows :

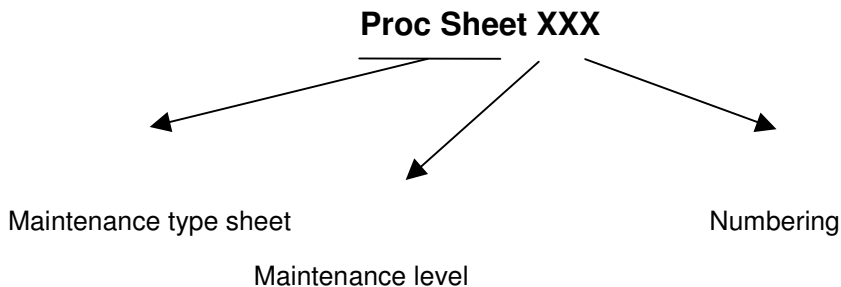

MAINTENANCE TOOLS

The following tools are necessary to carry out maintenance operations :

- Electrical screwdrivers with tightening torque settings **(0.25 NM)** ,equipped with 0,6 mm Torx .
- Metal dome jig.
- Plastic Tweezers.
- Gloves
- ESD protection strap

LEVEL 0 MAINTENANCE

 SAGEM	REMOVING / REPLACING BACK COVER	Proc Sheet 0 01
myX-3 & myX-5		1/2

4.4 Tools :

4.5 Not applicable.

4.6 Preliminary operation

Turn the handset upside down

4.7 Removal procedure :

- 1 Unlock the back cover (1) , by pushing the lock button (2) upwards.
- 2 Remove rear cover (1) by lifting bottom end first

4.8 Placement procedure :

1. Replace the cover by engaging top hooks first .
2. Push down back of rear cover and push button back into locked position

4.9 Further operations :

1. Check the covers are assembled tightly

 SAGEM	REMOVING / REPLACING THE BACK COVER	Proc sheet 0 01
myX-3 & myX-5		2/2

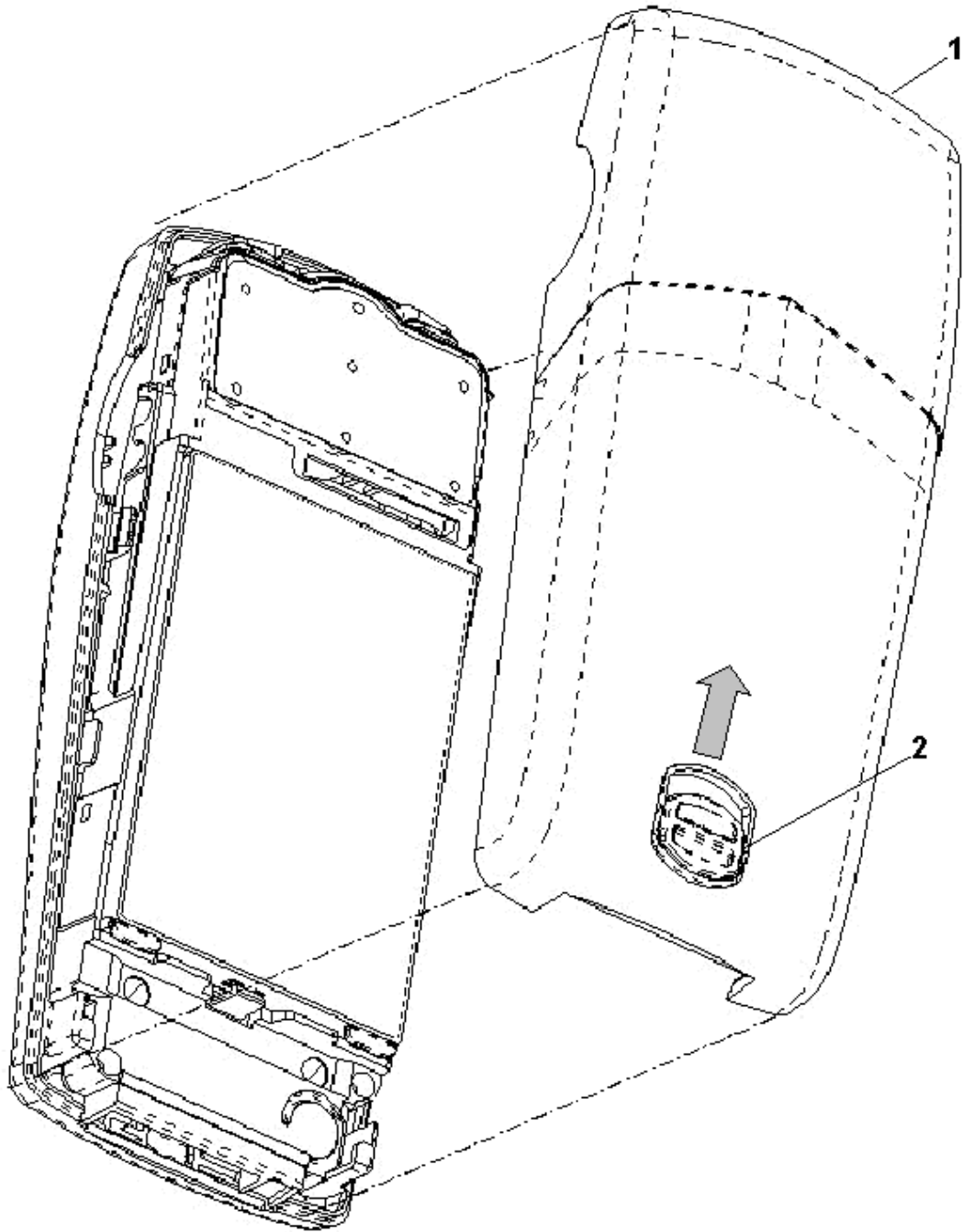

 SAGEM	REMOVING / REPLACING THE BATTERY	Proc Sheet 0 02
myX-3 & myX-5		1/2

4.10 Tools :

4.11 - Not applicable

4.12 Preliminary operation :

4.13 - Switch off the mobile phone

4.14 Removal procedure :

1. Remove the back cover ([Proc sheet 0 01](#)).
2. Take out the battery (1) by first extracting the stop pins (2).

4.15 Placement procedure :

1. Place the battery by first inserting the upper section .
2. Place the back cover ([Proc sheet 0 01](#)).

 SAGEM	REMOVING / REPLACING THE BATTERY	Proc Sheet 0 02
myX-3 & myX-5		2/2

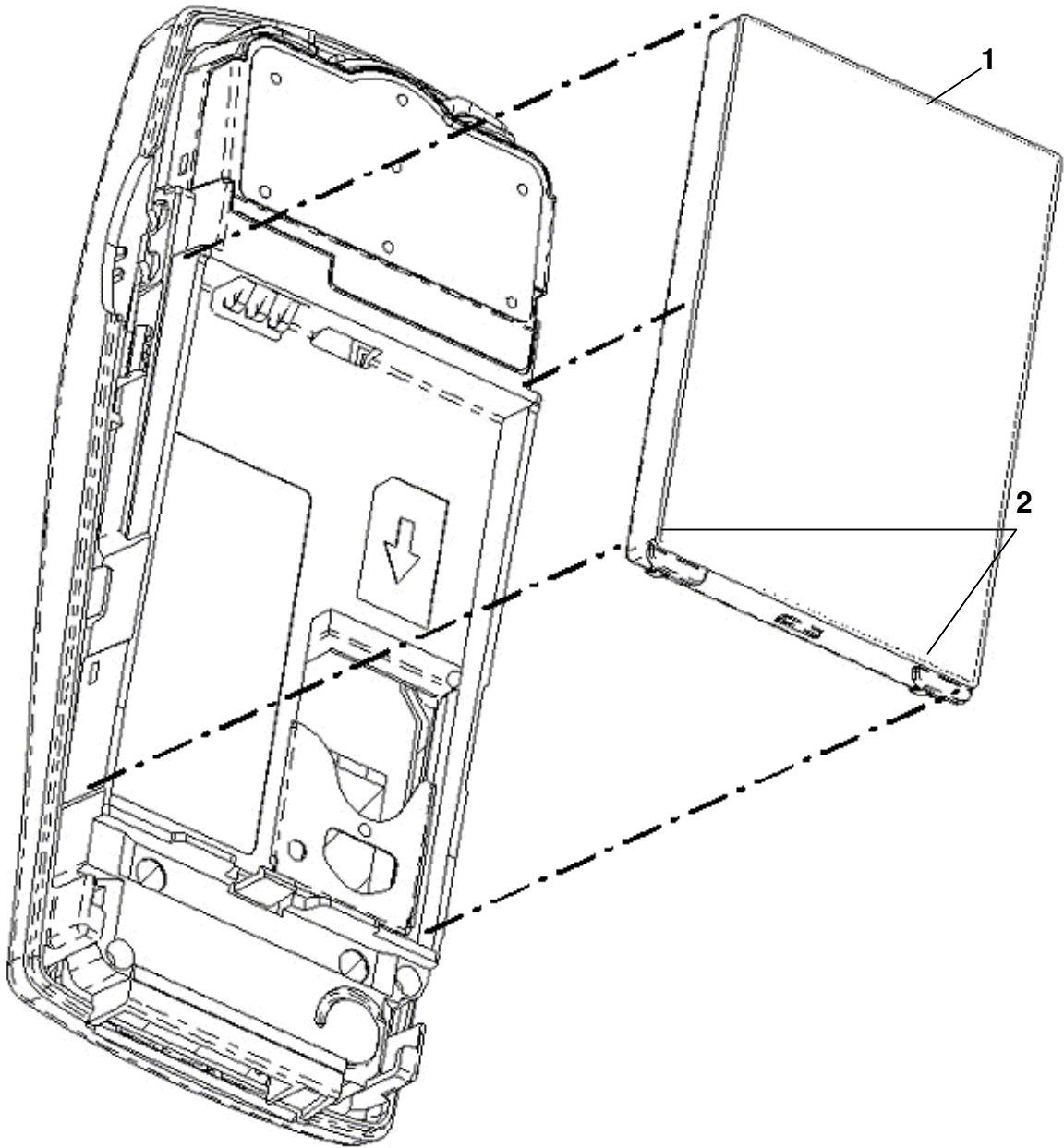

 SAGEM	REMOVING / REPLACING THE FRONT COVER	Proc Sheet 0 03
myX-3 & myX-5		1/2

4.16 **Tools :**

- Not applicable

4.17 **Preliminary operation :**

1. Remove the back cover ([Proc sheet 0 01](#)).

4.18 **Removal procedure :**

30. Separate the two front cover (2) fixing stop pins (3) to release the electronic module (1).
31. Remove the equipped front cover (2).
32. Remove the elastomer keypad (4).

4.19 **Placement procedure :**

1. On the new front cover (2), position the elastomer keypad (4) in position, ensuring it is free of dust.
2. Place the module (1) onto front cover (2) ,engaging firstly the module top, then press on the module top (1)

4.20 **Further operations**

1. Place the back cover ([Proc sheet 0 01](#)).

 SAGEM	REMOVING / REPLACING THE FRONT COVER	Proc sheet 0 03
myX-3 & myX-5		2/2

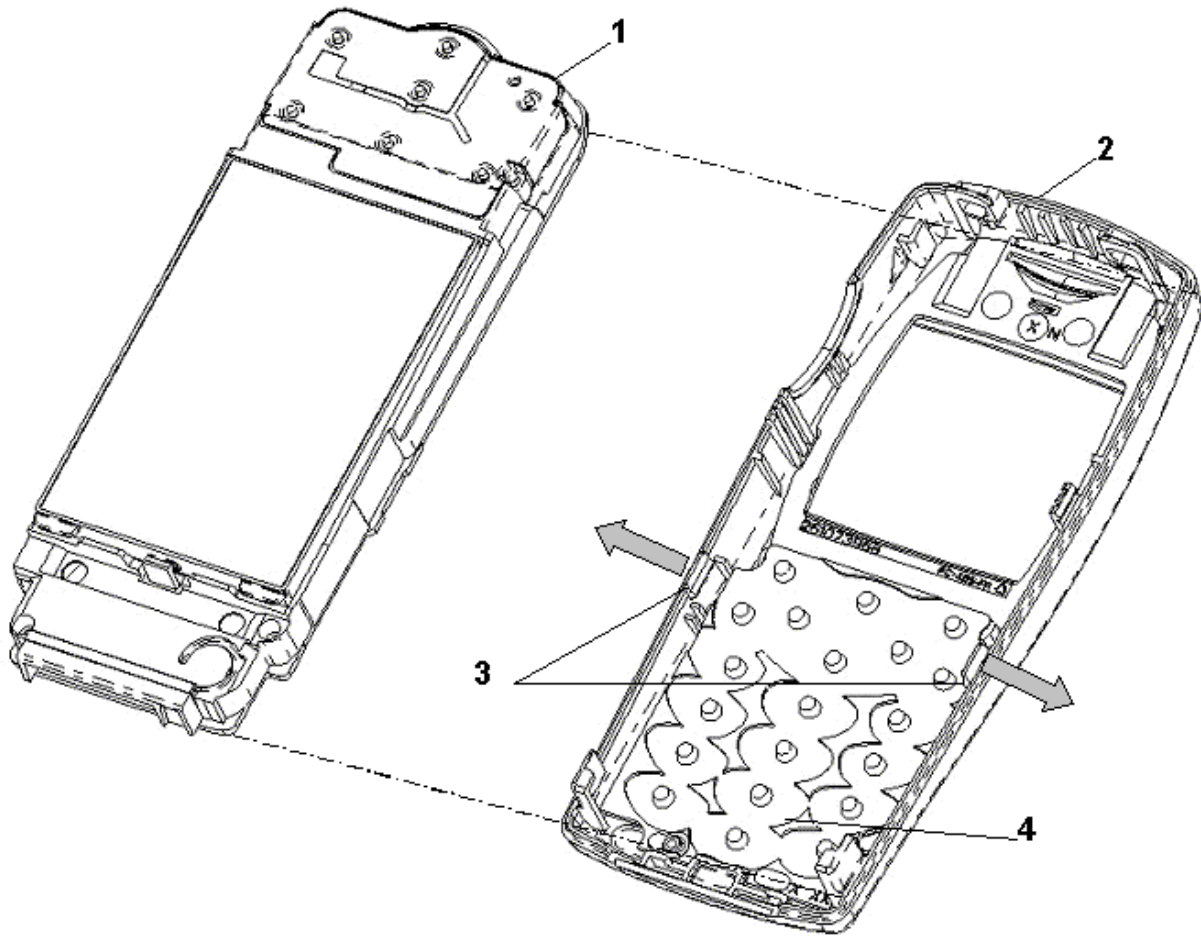

 SAGEM	REMOVING / REPLACING THE ELASTOMER KEYPAD	Proc Sheet 0 04
myX-3 & myX-5		1/2

4.21 Tools :

- Not applicable

4.22 Preliminary operation

1. Remove the back cover ([Proc sheet 0 01](#)).
2. Remove the front cover ([Proc sheet 0 03](#)).

4.23 Removal procedure :

1. Remove the elastomer keypad (2) from the front cover (1).

4.24 Placement procedure :

1. Clean the elastomer keypad (2) with compressed air.
2. Place the elastomer keypad (2) in position in its housing

4.25 Further operations :

1. Replace the front cover ([Proc sheet 0 03](#)).
2. Replace the back cover ([Proc sheet 0 01](#)).

 SAGEM	REMOVING / REPLACING THE ELASTOMER KEYPAD	Proc Sheet 0 04
myX-3 & myX-5		2/2

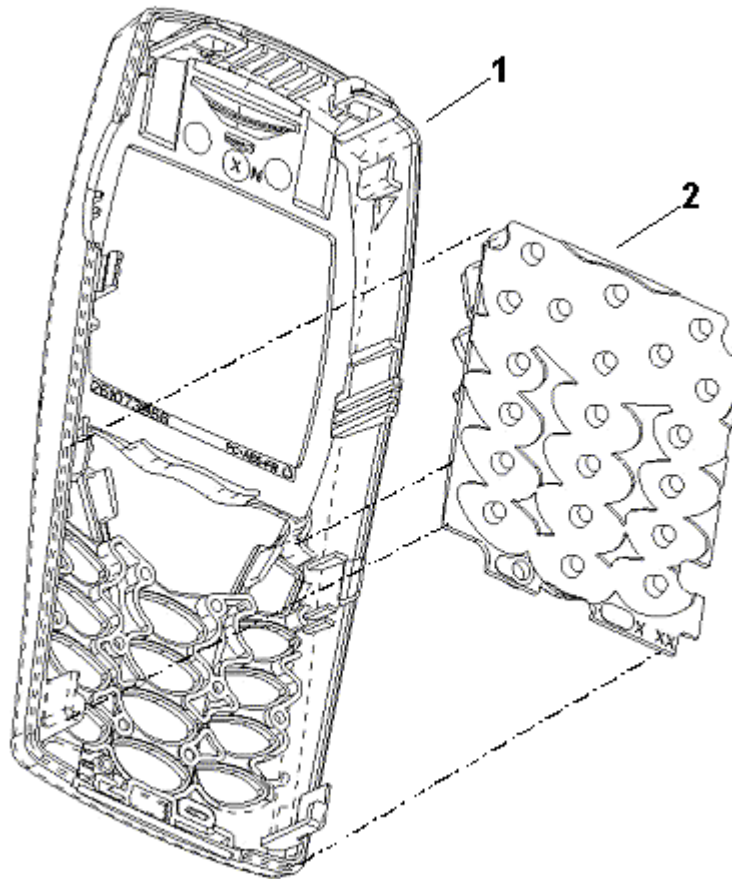

	REMOVING / REPLACING THE KNOB LOCK AND THE LOCKER	Proc Sheet 0 05
myX-3 & myX-5		1/2

4.26 Tools :

- Not applicable

4.27 Preliminary operation

33. Remove the back cover ([Proc sheet 0 01](#)).

4.28 Removal procedure :

1. Push the knob lock (1) upward .
2. Pull out the knob lock (1).
3. In the internal cover side ,slide the locker (3) upward, while lifting it.

4.29 Placement procedure :

1. Place the knob lock (3) in its housing, then slide it downward.
2. Turn the rear cover upside down and et press the knob lock firmly.

4.30 Further operations :

1. Replace the back cover ([Proc sheet 0 01](#)).

 SAGEM	REMOVING / REPLACING THE KNOB LOCK AND THE LOCKER	Proc Sheet 0 05
myX-3 & myX-5		2/2

KNOB LOCK

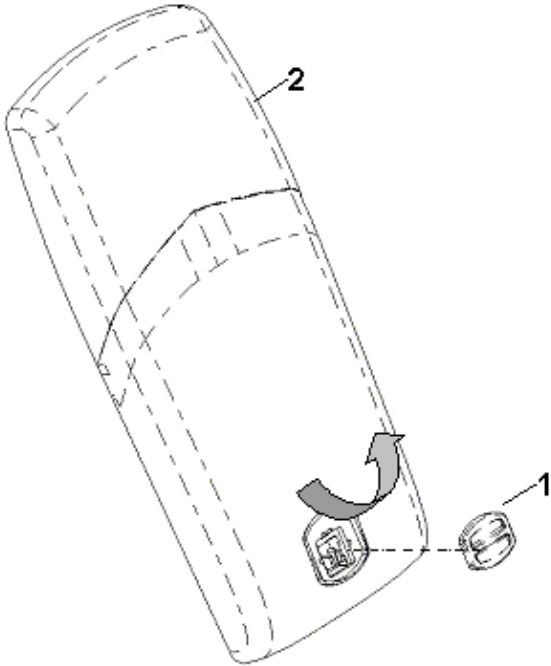

LOCKER

 SAGEM	REMOVING / REPLACING THE KNOB LOCK AND THE LOCKER	Proc Sheet 0 05
myX-3 & myX-5		2/2

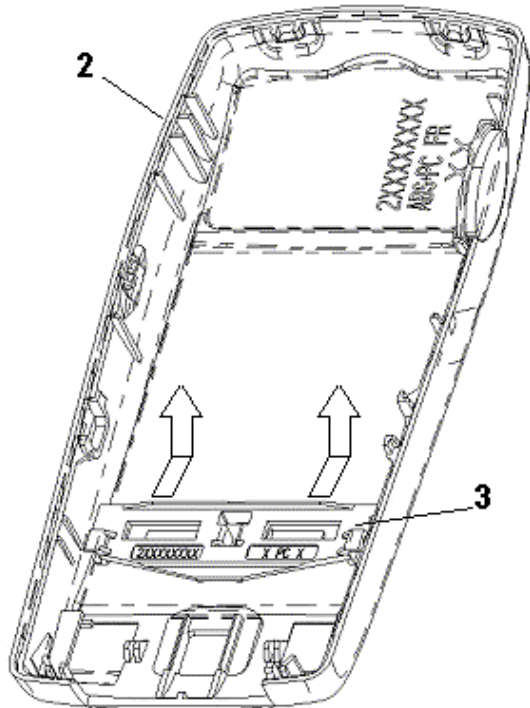

LEVEL 1 MAINTENANCE

 SAGEM	REMOVING / REPLACING THE DISPLAY	Proc Sheet 1 02
myX-3 & myX-5		1/2

4.31 Tools :

- A 0.6mm torx screwdriver
- gloves

- **This procedure must be performed by a technician provided with gloves , to avoid any risk of pollution.**
- **Contacts of display must be never touched.**

4.32 Preliminary operation

1. Remove the back cover ([Proc sheet 0 01](#)).
2. Remove the battery ([Proc sheet 0 02](#)).
3. Remove the front cover ([Proc sheet 0 03](#)).

4.33 Removal procedure :

1. On the electronic equipped module , unscrew the four attachment screws (5) .
2. Remove the assembly display (1) (2) (3).
1. Remove the display (3), of the support (2) by pushing it in its centre .

4.34 Placement procedure :

1. Replace the display (3) of the support (2),beginning with the bottom.
2. Replace the assembly display (1) (2) (3) on the electronic equipped module (4).
3. Position and tighten the four attachments screws with torx couple of **0,25 N.m.**
4. Verify that there are no impurities on the display.

4.35 Further operations :

1. Replace the front cover ([Proc sheet 0 03](#)).
2. Replace the battery ([Proc sheet 0 02](#)).
3. Replace the back cover ([Proc sheet 0 01](#)).
4. Set the display parameters with OMM software (**only for myX-5**) ([Test Sheet 01](#))
5. Carry out the radio test ([Test Sheet 06](#)).

 SAGEM	REMOVING / REPLACING THE DISPLAY	Proc Sheet 1 02
myX-3 & myX-5		2/2

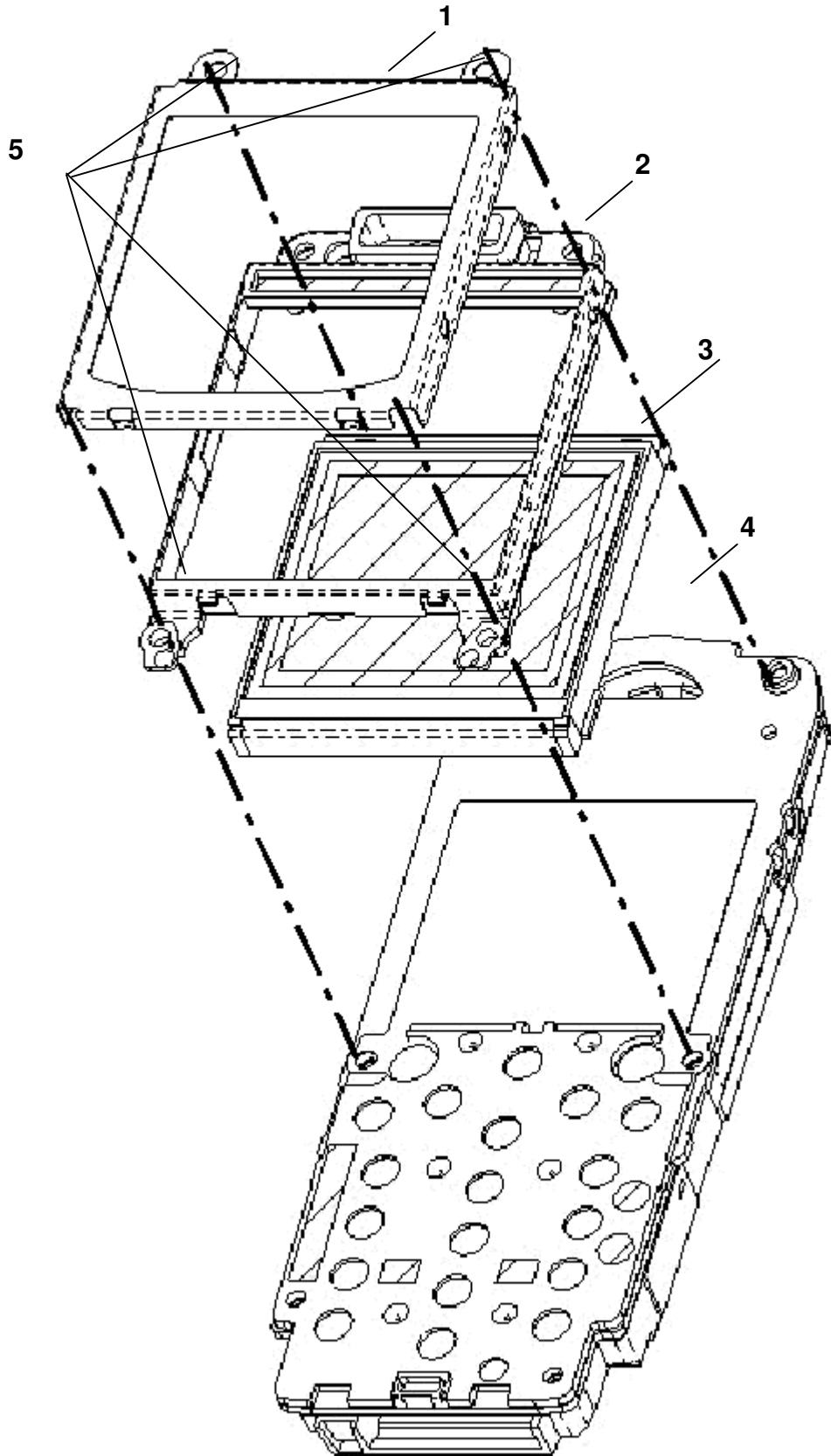

 SAGEM	REMOVING / REPLACING THE LIGHT GUIDE KEYPAD	Proc Sheet 1 03
myX-3 & myX-5		1/2

4.36 **Tools :**

- A 0.6mm torx screwdriver

4.37 **Preliminary operation**

1. Remove the back cover ([Proc sheet 0 01](#)).
2. Remove the battery ([Proc sheet 0 02](#)).
3. Remove the front cover ([Proc sheet 0 03](#)).

4.38 **Removal procedure :**

1. Unscrew the six attachment screws on the assembly plate (1)
2. Remove the assembly display ([Proc sheet 1.02](#))
3. Remove the light guide keypad (2).

4.39 **Placement procedure :**

1. Replace the new light guide keypad on its housing.
2. Replace the assembly display ([Proc sheet 1.02](#))
3. Position and tighten the six attachments screws with torx couple of **0,25 N.m.**

4.40 **Further operations :**

1. Replace the front cover ([Proc sheet 0 03](#)).
2. Replace the battery ([Proc sheet 0 02](#)).
3. Replace the back cover ([Proc sheet 0 01](#)).
4. Carry out radio test ([Test Sheet 06](#)).

 SAGEM	REMOVING / REPLACING THE LIGHT GUIDE KEYPAD	Proc Sheet 1 03
myX-3 & myX-5		2/2

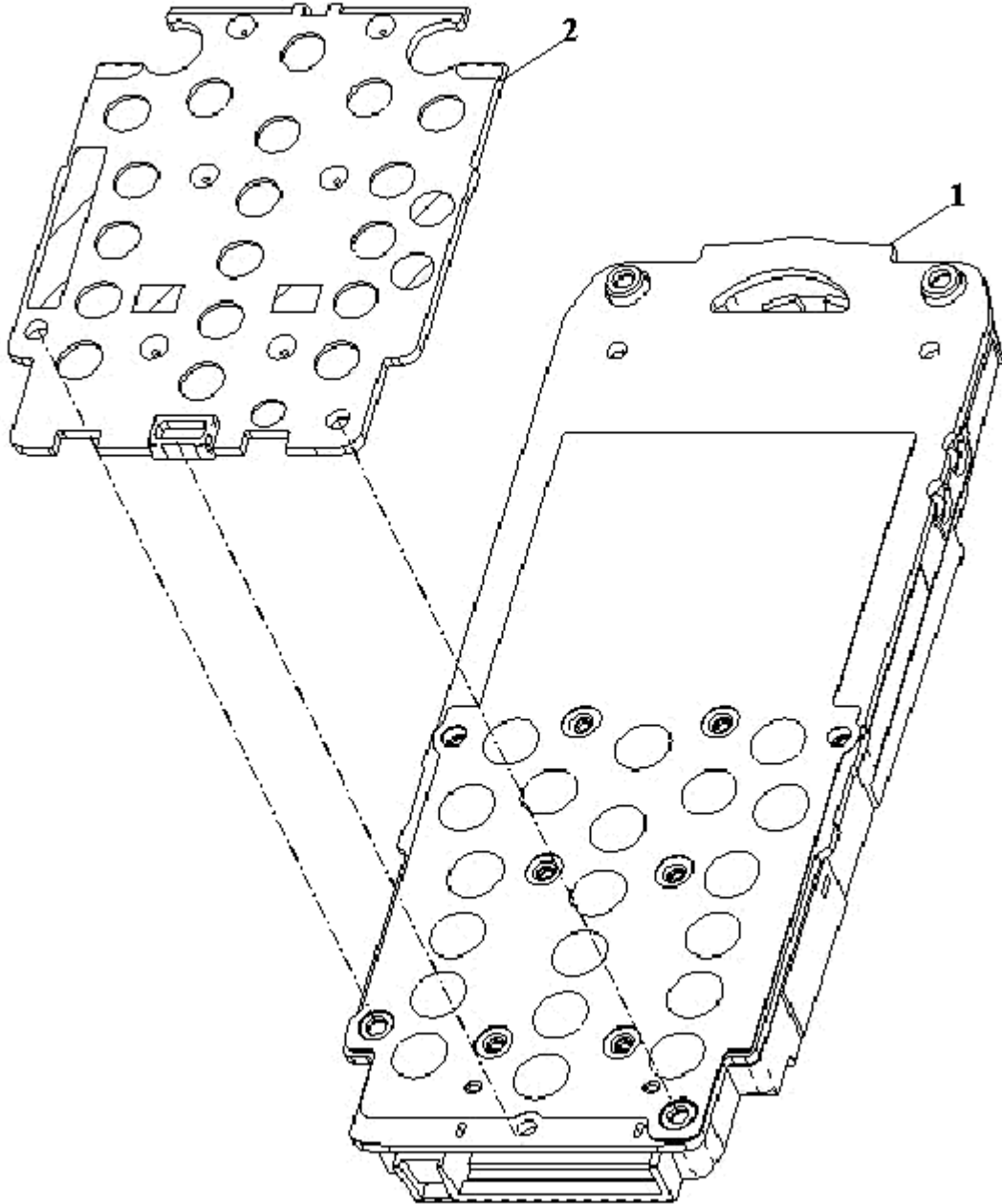

	REMOVING / REPLACING THE ELECTRONIC BOARD	Proc Sheet 1 04
myX-3 & myX-5		1/2

4.41 Tools :

- A 0.6mm torx screwdriver

4.42 Preliminary operation

1. Remove the back cover ([Proc sheet 0 01](#)).
2. Remove the battery ([Proc sheet 0 02](#)).
3. Remove the front cover ([Proc sheet 0 03](#)).

4.43 Removal procedure :

1. Unscrew the six attachment screws on the assembly plate (2)
2. Remove the assembly display ([Proc sheet 1 02](#))
3. Remove the light guide keypad ([Proc sheet 1 03](#))
4. Remove the electronic board (1) on the assembly plate (2).([Proc sheet 1 10](#))

4.44 Placement procedure :

1. Replace the new electronic board on the assembly plate (2).([Proc sheet 1 10](#))
2. Replace the light guide keypad on its housing.
3. Replace the assembly display ([Proc sheet 1.02](#))
4. Position and tighten the six attachments screws with torx couple of **0,25 N.m.**

4.45 Further operations :

1. Replace the front cover ([Proc sheet 0 03](#)).
2. Replace the battery ([Proc sheet 0 02](#)).
3. Replace the back cover ([Proc sheet 0 01](#)).
4. Carry out the radio test ([Test Sheet 06](#)).

 SAGEM	REMOVING / REPLACING THE ELECTRONIC BOARD	Proc Sheet 1 04
myX-3 & myX-5		2/2

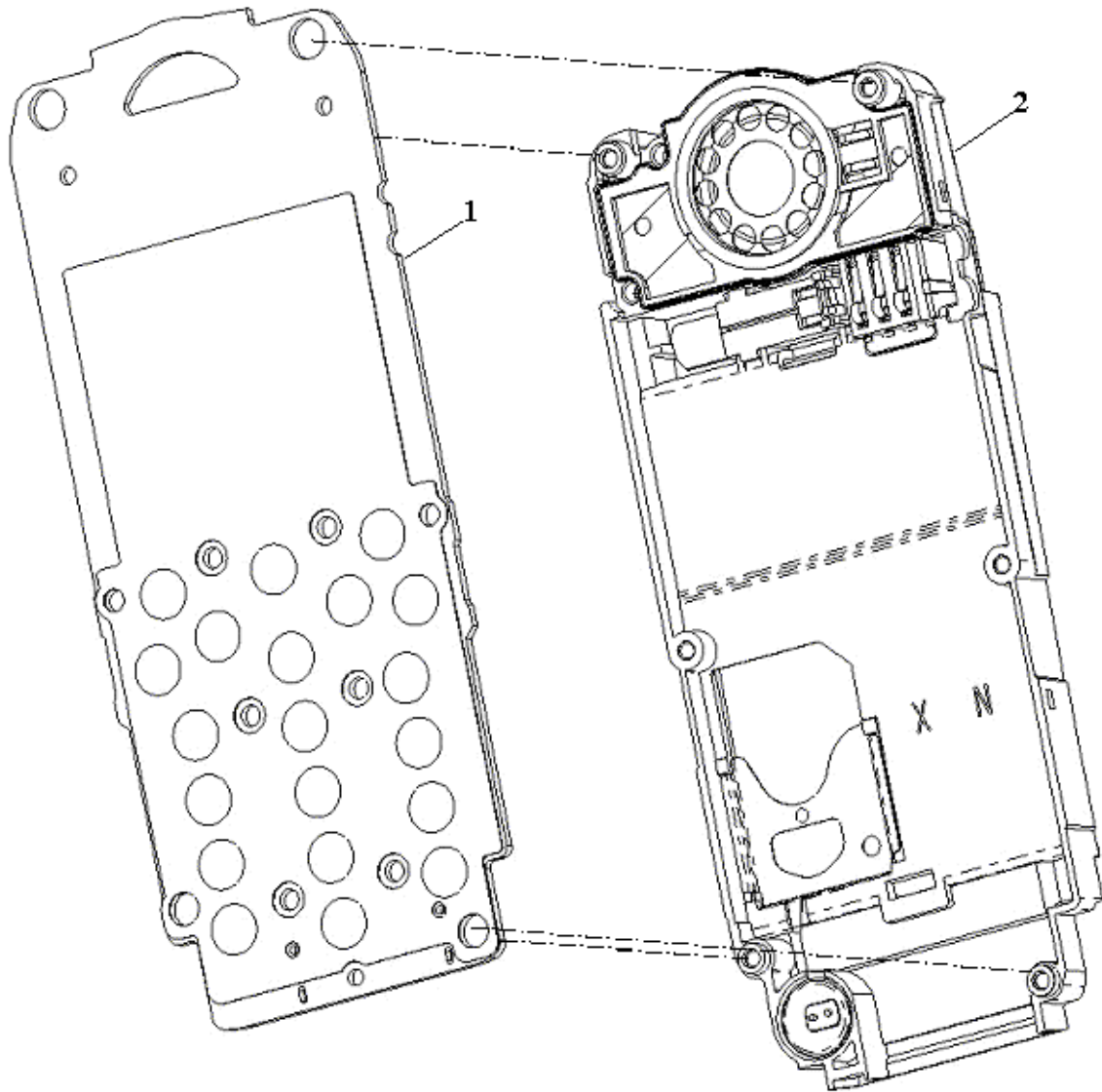

 SAGEM	REMOVING / REPLACING THE METAL DOME	Proc Sheet 1 05
myX-3 & myX-5		2/2

4.46 Tools :

- A 0.6mm torx screwdriver
- Gloves
- Metal dome Jig
- Tweezers

4.47 Preliminary operation

This procedure must be performed by a technician with gloves.

1. Remove the back cover ([Proc sheet 0 01](#)).
2. Remove the battery ([Proc sheet 0 02](#)).
3. Remove the front cover ([Proc sheet 0 03](#)).
4. Unscrew the six attachment screws on the electronic board (1)
5. Remove the assembly display ([Proc sheet 1 02](#)),then the light guide keypad ([Proc sheet 1 03](#))

4.48 Removal procedure :

1. Lift up the metal dome (2) on the electronic card (1) with tweezers.

4.49 Placement procedure :

Warning : The metal dome is not reusable, it must be necessarily replaced by a new metal dome, unless the board is swapped and sent as level 3

1. Replace the metal dome on the electronic card , using the metal dome jig.

4.50 Further operations :

1. Replace the new electronic board on the assembly plate (2).([Proc sheet 1.04](#))
2. Replace the light guide keypad ([Proc sheet 1.03](#))
3. Replace the assembly display ([Proc sheet 1.02](#))
4. Position and tighten the six attachments screws with torx settings of **0,25 N.m.**
5. Replace the front cover ([Proc sheet 0 03](#)).
6. Replace the battery ([Proc sheet 0 02](#)).
7. Replace the back cover ([Proc sheet 0 01](#)).
8. Carry out the radio test ([Test Sheet 06](#)).

 SAGEM	REMOVING / REPLACING THE METAL DOME	Proc Sheet 1 05
myX-3 & myX-5		2/2

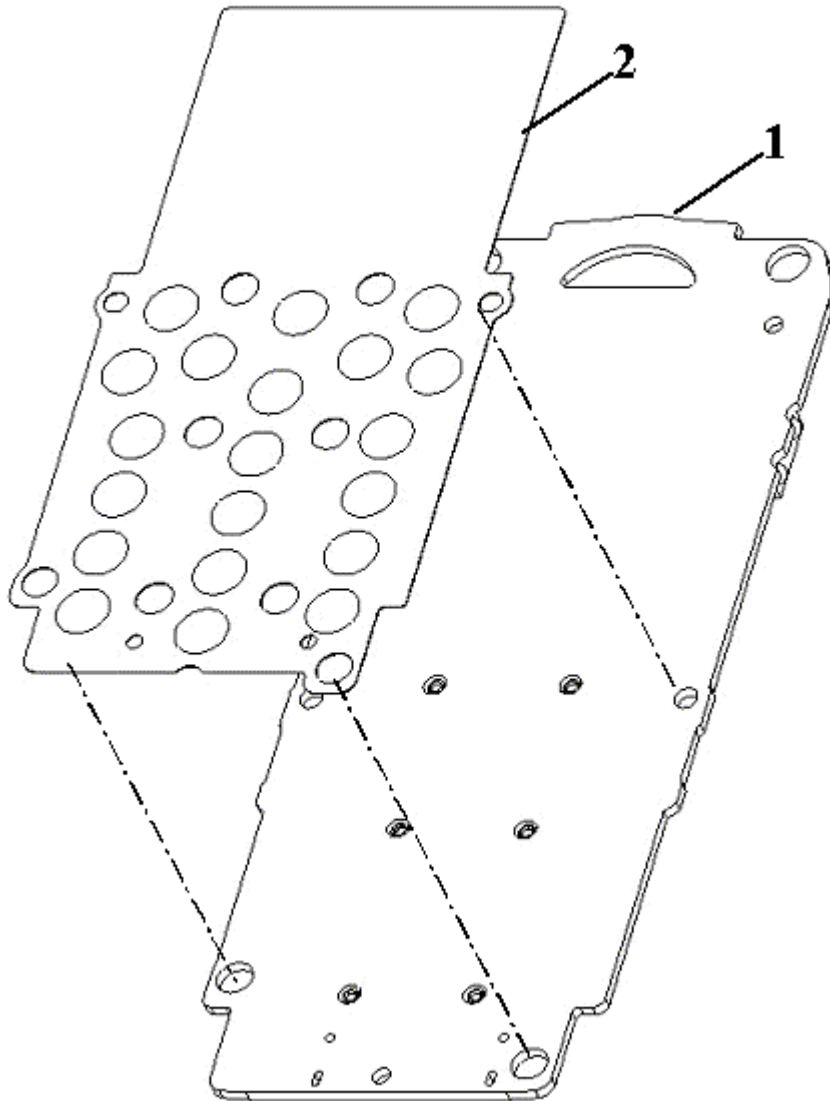

 SAGEM	REMOVING / REPLACING THE SIM LOCKER	Proc Sheet 1 06
myX-3 & myX-5		1/2

4.51 **Tools :**

- A 0.6mm torx screwdriver

4.52 **Preliminary operation :**

1. Remove the back cover ([Proc sheet 0 01](#)).
2. Remove the battery ([Proc sheet 0 02](#)).
3. Remove the SIM card .
4. Remove the front cover ([Proc sheet 0 03](#)).
5. Unscrew the six attachment screws on the electronic board .
6. Remove the assembly display ([Proc sheet 1 02](#))
7. Remove the light guide keypad ([Proc sheet 1 03](#))
8. Remove the electronic board.([Proc sheet 1 04](#))

4.53 **Removal procedure :**

1. On the assembly plate (2), looked at from the battery side ,press firmly the SIM locker (1) until its extraction .
2. Remove the SIM cover (1).

4.54 **Placement procedure :**

1. Place the SIM cover (1) in position in its housing.
2. Click fit the SIM cover (1) on the plate.

4.55 **Further operations :**

1. Remove the electronic board on the assembly plate.([Proc sheet 1 04](#))
2. Replace the light guide keypad ([Proc sheet 1.03](#))
3. Replace the assembly display ([Proc sheet 1 02](#))
4. Position and tighten the six attachments screws with torque of **0,25 N.m.**
5. Replace the front cover /battery / back cover ([Proc sheet 0 01 / 0 02 / 0 03](#)).
6. Carry out the radio test ([Test Sheet 06](#)).

 SAGEM	REMOVING / REPLACING THE SIM LOCKER	Proc Sheet 1 06
myX-3 & myX-5		2/2

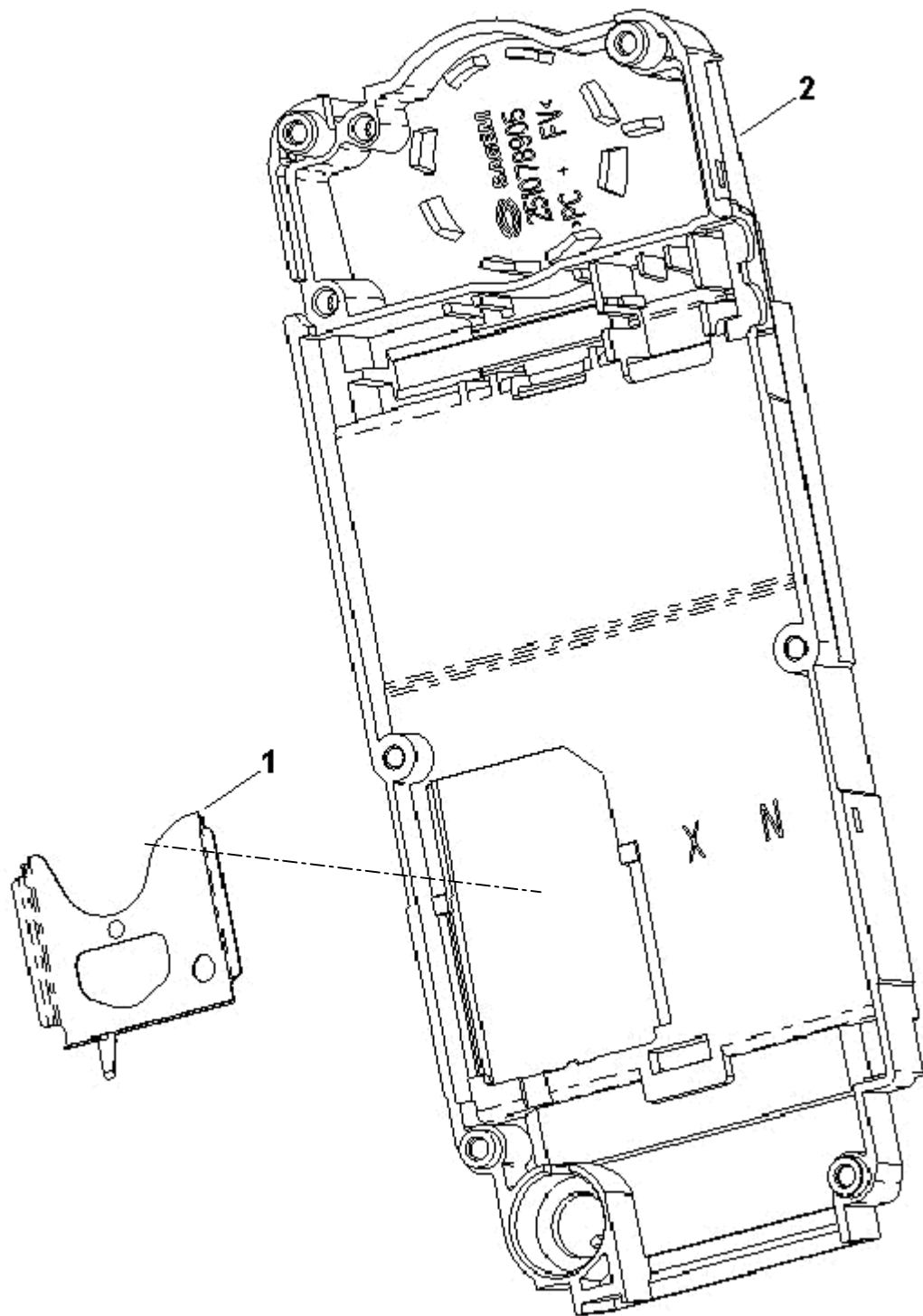

 SAGEM	REMOVING / REPLACING THE BATTERY CONNECTOR	Proc Sheet 1 07
myX-3 & myX-5		1/2

4.56 Tools :

- A 0.6mm torx screwdriver
- Tweezers

4.57 Preliminary operation

1. Remove the back cover ([Proc sheet 0 01](#)).
2. Remove the battery ([Proc sheet 0 02](#)).
3. Remove the front cover ([Proc sheet 0 03](#)).
4. Unscrew the six attachment screws on the electronic board.
5. Remove the assembly display , then the light guide keypad ([Proc sheet 1 02 / 1 03](#))
6. Remove the electronic board.([Proc sheet 1 04](#))

4.58 Removal procedure :

1. Remove the battery connector (1) , using tweezers

4.59 Placement procedure :

1. Place the battery connector (1) in position in its housing , respecting the foolproof device.

4.60 Further operations :

1. Remove the electronic board on the assembly plate.([Proc sheet 1 04](#))
2. Replace the light guide keypad ([Proc sheet 1.03](#))
3. Replace the assembly display ([Proc sheet 1 02](#))
4. Position and tighten the six attachments screws with torx settings of **0,25 N.m.**
5. Replace the front cover /battery / back cover ([Proc sheet 0 01 / 0 02 / 0 03](#)).
6. . Carry out the radio test ([Test Sheet 06](#)).

 SAGEM	REMOVING / REPLACING THE BATTERY CONNECTOR	Proc Sheet 1 07
myX-3 & myX-5		2/2

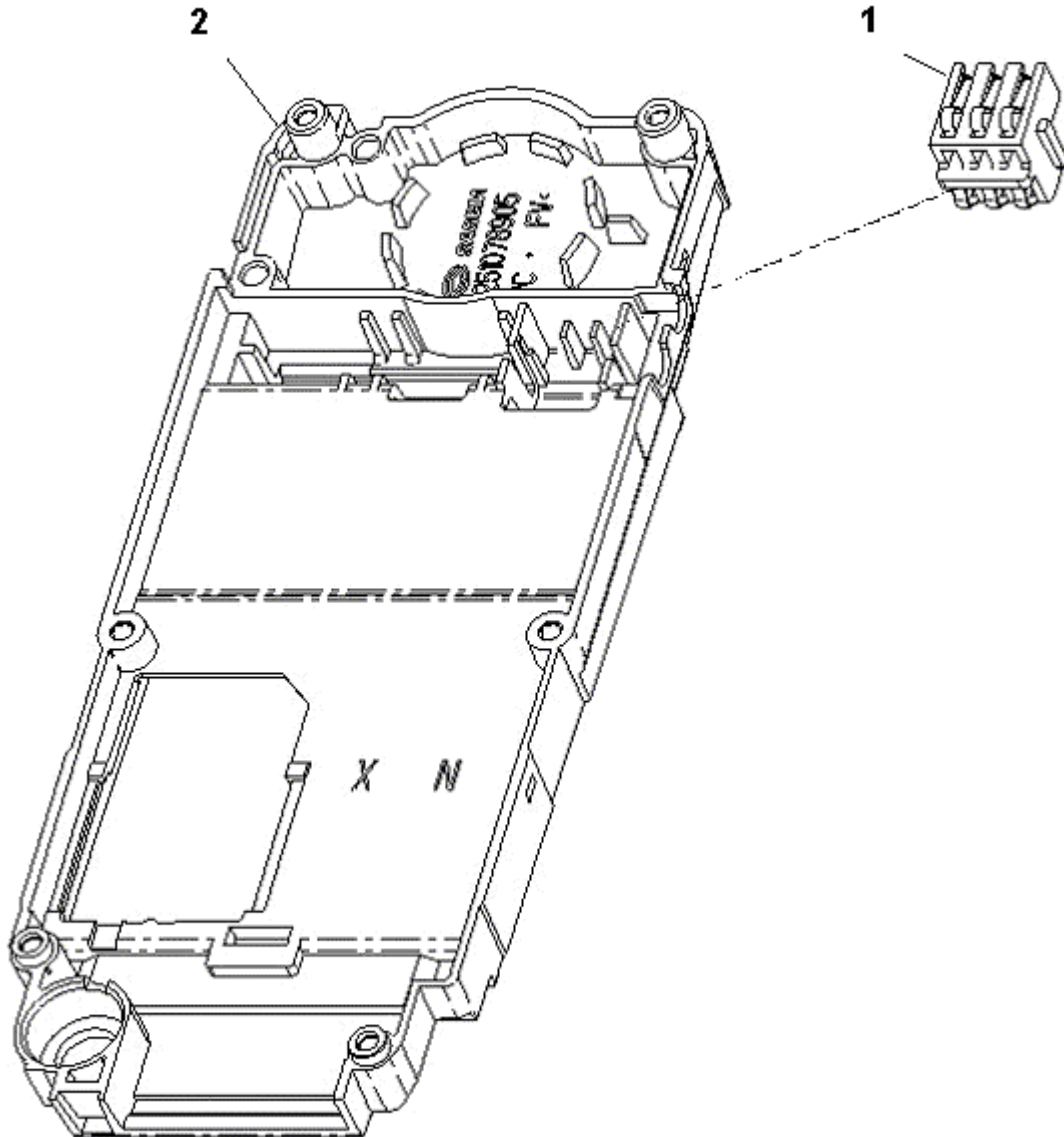

 SAGEM	REMOVING / REPLACING THE MICROPHONE	Proc Sheet 1 08
myX-3 & myX-5		1/2

4.61 Tools :

- A 0.6mm torx screwdriver
- Tweezers

4.62 Preliminary operation

1. Remove the back cover ([Proc sheet 0 01](#)).
2. Remove the battery ([Proc sheet 0 02](#)).
3. Remove the front cover ([Proc sheet 0 03](#)).
4. Unscrew the six attachment screws on the electronic board.
5. Remove the assembly display , then the light guide keypad ([Proc sheet 1 02 / 1 03](#))
6. Remove the electronic board.([Proc sheet 1 04](#))

4.63 Removal procedure:

1. Remove the microphone (1) , using tweezers.

4.64 Placement procedure :

1. Put the microphone (1) in position in its housing (2).

4.65 Further operations :

1. Remove the electronic board on the assembly plate. .([Proc sheet 1 04](#))
2. Replace the light guide keypad ([Proc sheet 1.03](#))
3. Replace the assembly display ([Proc sheet 1 02](#))
4. Position and tighten the six attachments screws with torx settings of **0,25 N.m.**
5. Replace the front cover /battery / back cover ([Proc sheet 0 01 / 0 02 / 0 03](#)).
6. Carry out the radio test ([Test Sheet 06](#)).

 SAGEM	REMOVING / REPLACING THE MICROPHONE	Fiche Proc 1 08
myX-3 & myX-5		2/2

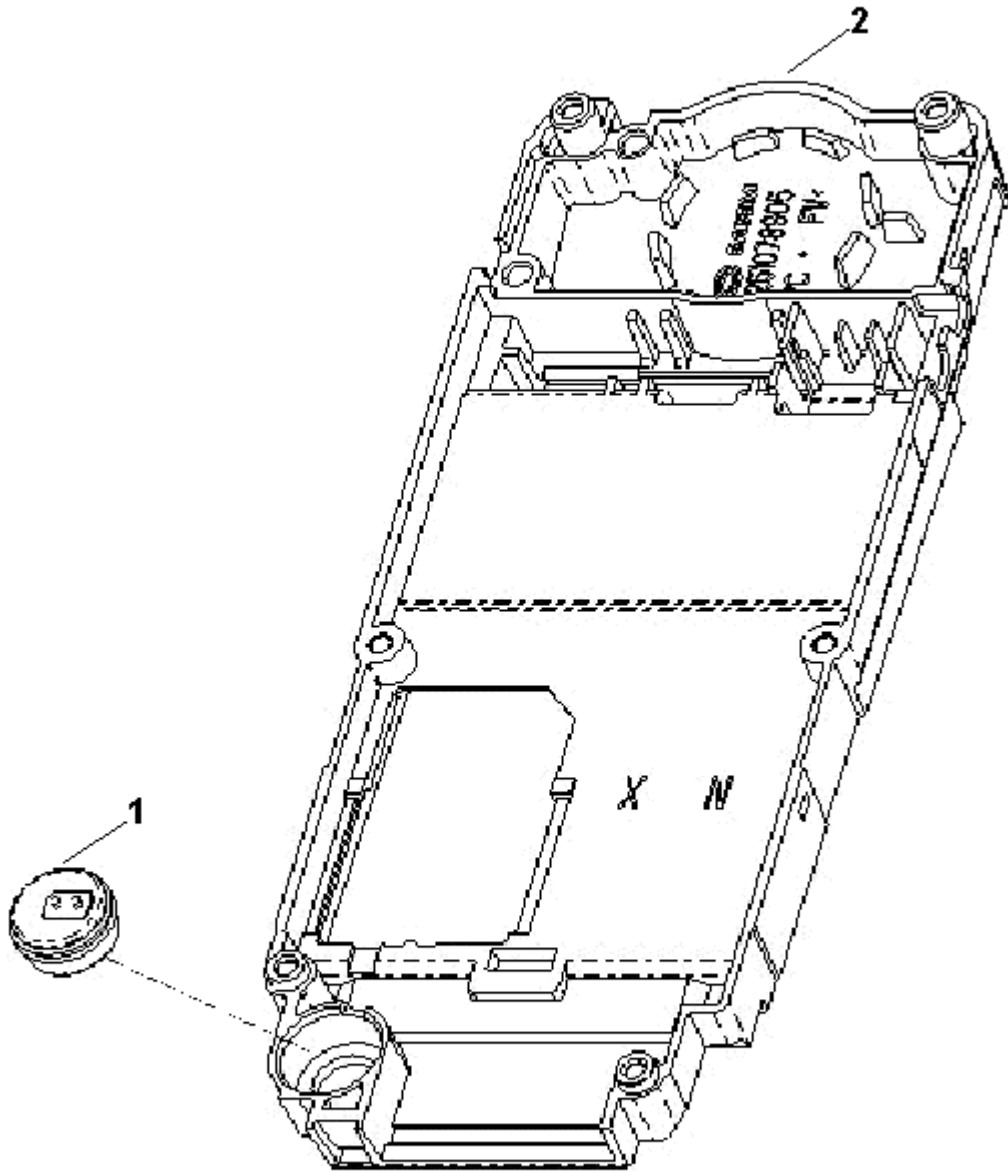

 SAGEM	REMOVING / REPLACING THE LOUDSPEAKER	Proc Sheet 1 09
myX-3 & myX-5		1/2

4.66 Tools :

- A 0.6mm torx screwdriver
- Tweezers

4.67 Preliminary operation

1. Remove the back cover ([Proc sheet 0 01](#)).
2. Remove the battery ([Proc sheet 0 02](#)).
3. Remove the front cover ([Proc sheet 0 03](#)).
4. Unscrew the six attachment screws on the electronic board.
5. Remove the assembly display , then the light guide keypad ([Proc sheet 1 02 / 1 03](#))
6. Remove the electronic board.([Proc sheet 1 04](#))

4.68 Removal procedure :

Notice: do not touch the loudspeaker diaphragm

1. Remove, with the tweezers, the equipped loudspeaker (1) in its housing (2).

4.69 Placement procedure :

1. Put the loudspeaker in its housing, respecting the foolproof device

4.70 Further operations :

1. Remove the electronic board on the assembly plate. .([Proc sheet 1 04](#))
2. Replace the light guide keypad ([Proc sheet 1.03](#))
3. Replace the assembly display ([Proc sheet 1 02](#))
4. Position and tighten the six attachments screws with torx settings of **0,25 N.m.**
5. Replace the front cover /battery / back cover ([Proc sheet 0 01 / 0 02 / 0 03](#)).
6. Carry out the radio test ([Test Sheet 06](#)).

 SAGEM	REMOVING / REPLACING THE LOUDSPEAKER	Proc Sheet 1 09
myX-3 & myX-5		2/2

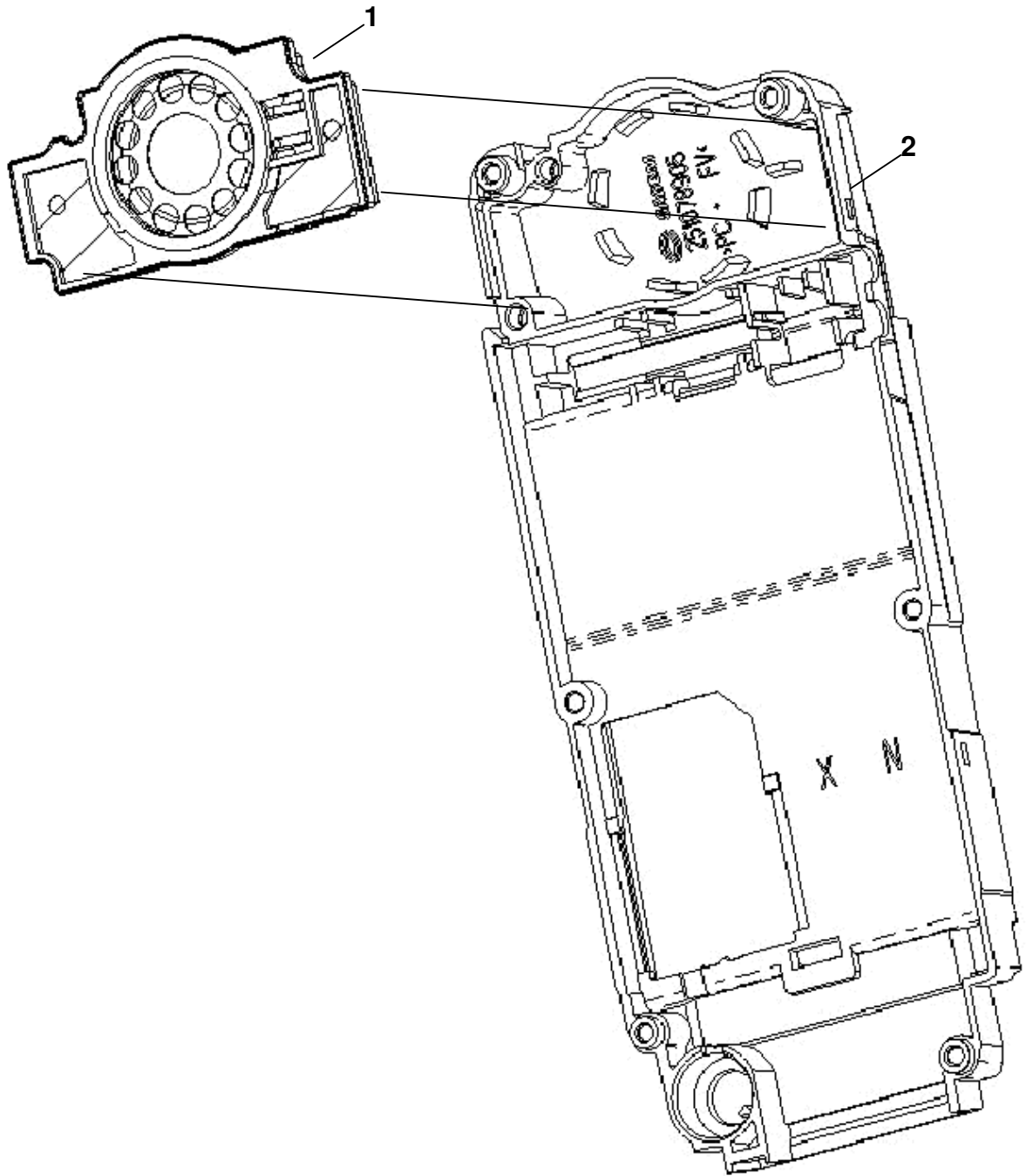

 SAGEM	REMOVING / REPLACING THE LOUDSPEAKER	Proc Sheet 1 09
myX-3 & myX-5		2/2

 SAGEM	REMOVING / REPLACING THE VIBRATING DEVICE	Proc Sheet 1 10
myX-3 & myX-5		1/2

4.71 Tools :

- A 0.6mm torx screwdriver
- Tweezers

4.72 Preliminary operation :

1. Remove the back cover ([Proc sheet 0 01](#)).
2. Remove the battery ([Proc sheet 0 02](#)).
3. Remove the front cover ([Proc sheet 0 03](#)).
4. Unscrew the six attachment screws on the electronic board.
5. Remove the assembly display , then the light guide keypad ([Proc sheet 1 02 / 1 03](#))
6. Remove the electronic board.([Proc sheet 1 04](#))

4.73 Removal procedure :

1. With tweezers, remove the vibrating device (1) .

4.74 Placement procedure :

1. Place the vibrating device (1) into position on the plate (2), respecting the foolproof device.

4.75 Further operations :

1. Remove the electronic board on the assembly plate. .([Proc sheet 1 04](#))
2. Replace the light guide keypad ([Proc sheet 1.03](#))
3. Replace the assembly display ([Proc sheet 1 02](#))
4. Position and tighten the six attachments screws with torx settings of **0,25 N.m.**
5. Replace the front cover /battery / back cover ([Proc sheet 0 01 / 0 02 / 0 03](#)).
6. Carry out the radio test ([Test Sheet 06](#)).

 SAGEM	REMOVING / REPLACING THE VIBRATING DEVICE	Proc Sheet 1 10
myX-3 & myX-5		1/2

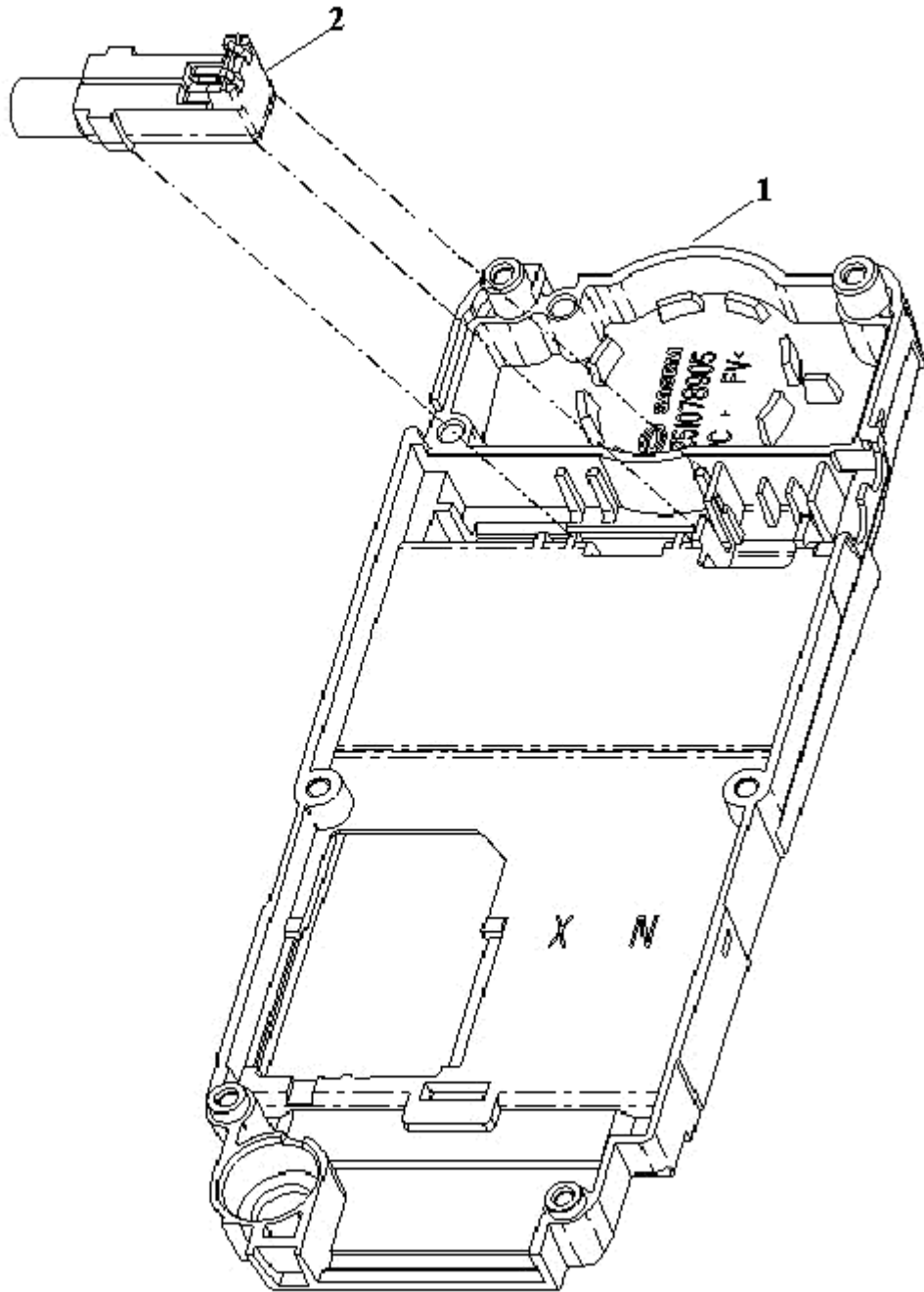

 SAGEM	ELECTRONIC BOARD EXCHANGE	Proc Sheet 1 11
myX-3 & myX-5		1/3

4.76 Preliminary operation

1. Control of the IMEI label integrity
2. Remove the electronic board (Proc sheet 1 04)
3. Control of any oxidation marks (on the electronic board and under the metal dome)

4.77 Return procedure :

- (a) The electronic boards are packaged in individual electrostatic envelopes . They must be stocked in their original package of reception , to insure a good protection against external attacks (see enclosed photos)
- (b) During the electronic boards manipulation , gloves and electrostatic strap must be worn at all times.
- (c) The defective electronic boards have to be returned to SAGEM factory, packaged individually, in the original package (see enclosed photos) , in the appropriate ESD box : One box per Sagem reference (check reference written on the box).
- (d) The defective board should display the defect code written on a sticker (placed on the shielding) and have the label provided with OMM on each ESD bag .

Note : The defective board must never be mixed with the complete mobiles

4.78 Placement procedure :

1. Take a board in the stock of swap boards from the same Sagem reference.

4.79 Further operations :

1. Place the new electronic board on the assembly plate. [.\(Proc sheet 1 04\)](#)
2. Replace the customer housing (Proc Sheet 0 03 et 1 01)
3. Follow stages (see enclosed photos)

 SAGEM	ELECTRONIC BOARD EXCHANGE	Proc sheet 1 11
myX-3 & myX-5		2/3

Example of electronic boards packaging :

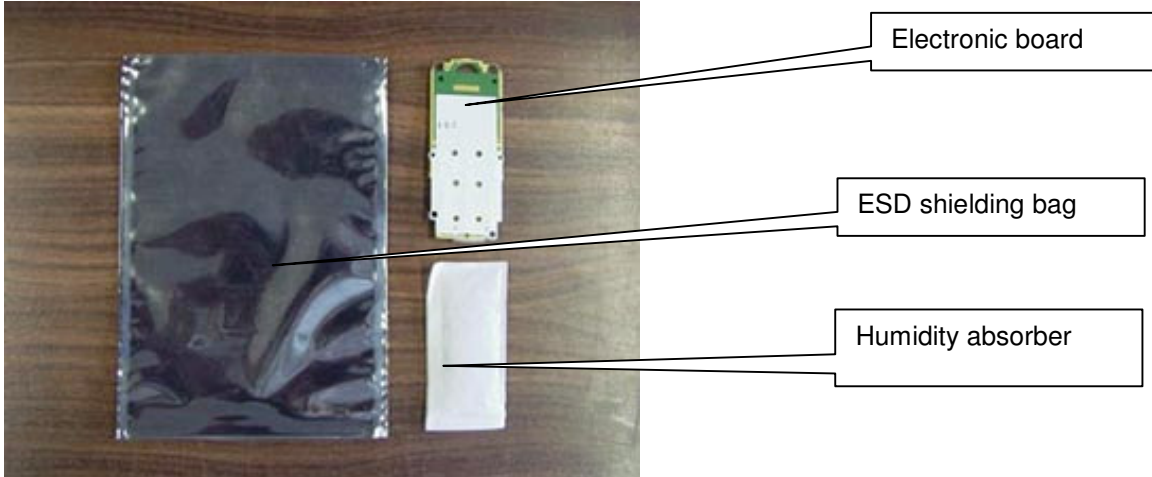

Boards packaging SAGEM -> ARC

Boards packaging ARC -> SAGEM



ESD shielding bag closed by the product label



ESD shielding bag closed by the IMEI label

 SAGEM	ELECTRONIC BOARD EXCHANGE	Proc sheet 1 11
myX-3 & myX-5		2/3

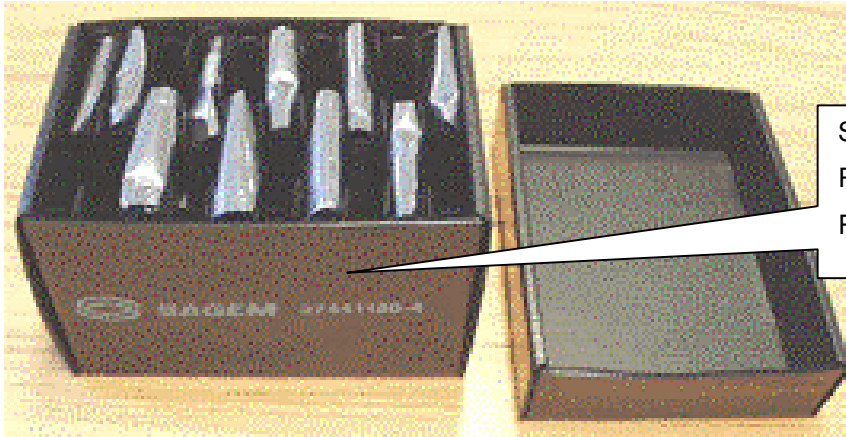

SAGEM electrostatic shielding box
Reference 20 boards: 27441180-4
Reference 100 boards: 27 511110-6

	ELECTRONIC BOARD EXCHANGE	Proc sheet 1 11
myX-3 & myX-5		3/3

Electronic board exchange process

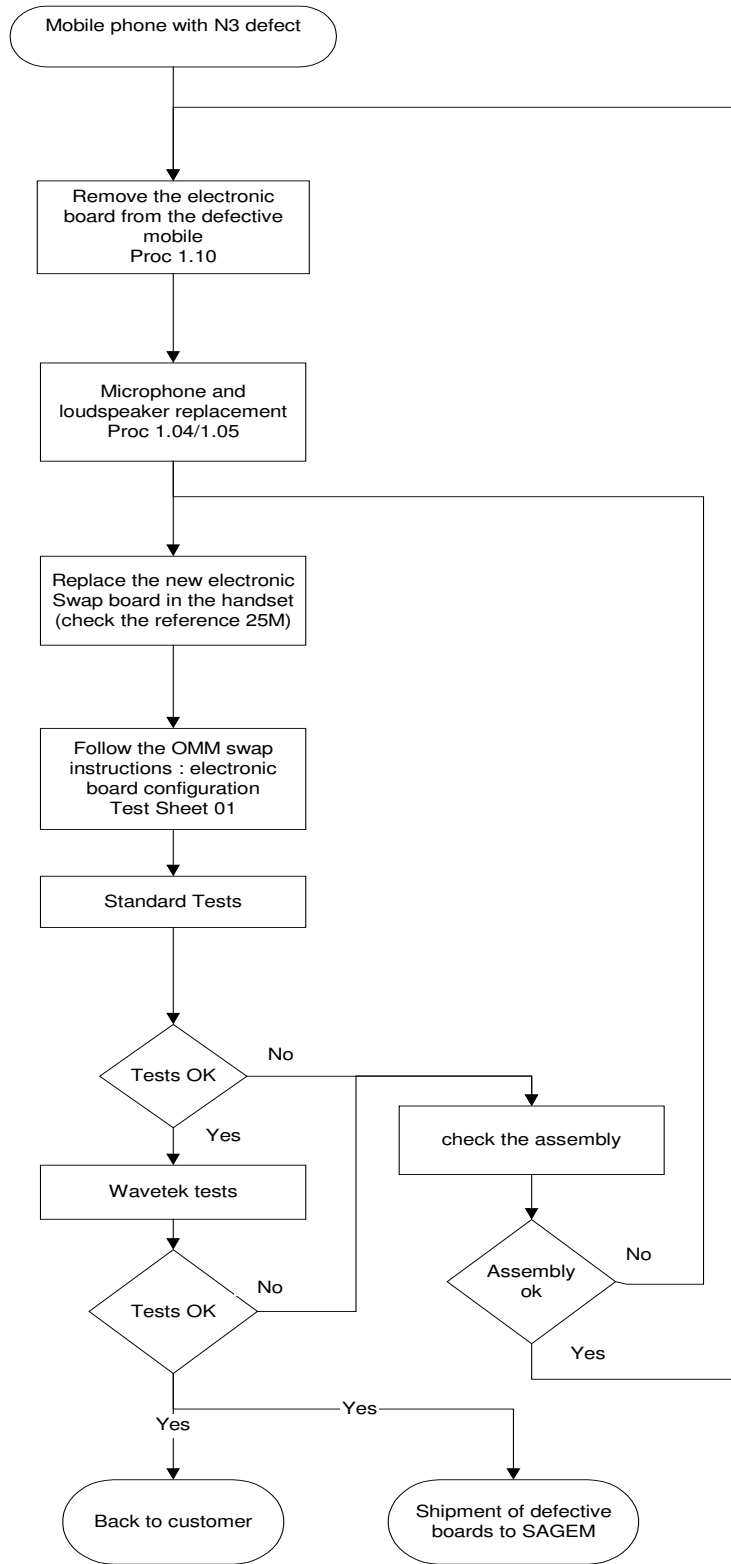

Detection of N3 defect : See the Technical documentation

-check the metal dome .
In case of damage or oxidation , replace it.

- Display test : Hot Line Menu
- Keypad test
- Vibrating device test

- See Technical documentation (test sheet 06)

- Follow return instructions page 5/7



ECHANGE CARTE ELECTRONIQUE

Fiche Proc 2 01

Tous types

3/3

LEVEL 3 MAINTENANCE

IMPORTANT

Mobile packaging sent to SAGEM S.A. :

Follow the Proc sheet 1.11

Packaging for swap or mobile components storage :

The swap and the mobile components must be stored with a particular care especially for the most sensible component (Display , loudspeaker etc...).

Code SAGEM		Type de défauts	Type of fault
PROBLEME D'AFFICHAGE		DISPLAY PROBLEM	
A1		PAS D AFFICHAGE LED E TEINTES	NO POWER UP
A2		PAS D AFFICHAGE LED ALLUMÉES	NO WAKE UP
A3		BLOCAGE DE L AFFICHAGE	FREEZES UP
A5		AFFICHEUR CASSE	BROKEN LCD
A6		LIGNE, DIGIT OU PIXEL MANQUANT, CONTRASTE, COULEUR	MISSING LINE, DIGIT or PIXEL, CONTRAST, COLOR
A7		PB HETHOECLAIRAGE	BACKLIGHTS PROBLEM
PROBLEME D'ANTENNE		ANTENNA PROBLEM	
A10		ANTENNE CASSEE / ABSENTE	BROKEN / MISSING ANTENNA
PROBLEME D'ALIMENTATION / CHARGEUR		POWER SUPPLY / CHARGING PROBLEM	
B1		CONTACT BATTERIE DU MOBILE DEFECTUEUX	DEFECTIVE MOBILE BATTERY CONTACT
B2		CONNECTEUR DE CHARGE DU MOBILE DEFECTUEUX	DEFECTIVE MOBILE CHARGER CONNECTOR
B3		ALIMENTATION CARTE DEFECTUEUSE	DEFECTIVE POWER SUPPLY OF THE BOARD
B4		AFFICHAGE CHARGE DEFECTUEUX	DEFECTIVE CHARGE ICON DISPLAY
B5		CONSOMMATION MODE ETEINT	CURRENT CONSUMPTION WITH PHONE OFF
B7		PROBLEME D AUTONOMIE	AUTONOMY
B8		BATTERIE DEFECTUEUSE	ELECTRICALLY DEFECTIVE BATTERY
B9		TENUE MECANIQUE BATTERIE	MECHANICAL LOCK PROBLEM ON BATTERY
B10		BATTERIE CASSEE	BROKEN BATTERY
B11		CHARGEUR DEFECTUEUX	DEFECTIVE CHARGER
B12		CHARGEUR CASSE	BROKEN CHARGER
B13		COUPURE INTERMITTENTE AVEC REDEMARRAGE	INTERMITTENT SWITCH OFF WITH REBOOT
B14		COUPURE INTERMITTENTE SANS REDEMARRAGE	INTERMITTENT SWITCH OFF WITHOUT REBOOT
PROBLEME DE CLAVIER		KEYBOARD PROBLEM	
C1		CLAVIER INOPERANT	NOT FUNCTIONING KEYBOARD
C2		PROBLEME TOUCHE LATERALE	LATERAL TOUCH PROBLEM
MESSAGE D'ERREUR		ERROR MESSAGE	
D1		SIM ABSENTE	SIM MISSING
D2		AUTRES MESSAGES	OTHER MESSAGES
D3		PB EEPROM	EEPROM
D4		MOBILE NON REGLE	UNTUNED MOBILE
D5		HARD FAILURE	HARD FAILURE
D6		SIM VERROU	SIM VERROU
D7		CODE POSTE	POST CODE BLOCKED
D8		RETOUR SAV	SAV RETURN
D9		BATTERIE INCONNUE	UNKNOWN BATTERY
PROBLEME AUDIO		AUDIO PROBLEM	
E1		HP DEFECTUEUX (grésille)	DEFECTIVE LOUDSPEAKER (hails)
E2		HP VOIX DEFORMEE OU PARASITES	LOUDSPEAKER VOICE DISTORTION
E3		MICRO DEFECTUEUX	DEFECTIVE MICROPHONE
E4		MICRO VOIX DEFORMEE OU PARASITE (DISTANT)	MICRO VOICE DISTORTION
E5		PROBLEME DE VIBREUR	VIBRATING DEVICE PROBLEM
E6		CONNECTEUR AUDIO DEFECTUEUX	DEFECTIVE AUDIO CONNECTOR
PROBLEME DE COMMUNICATION		COMMUNICATION PROBLEM	
F1		PAS DE LOCALISATION RESEAU	NO NETWORK RETRIEVAL
F2		COUPURE DE COMMUNICATION	INTERMITTENT CALLS DROP
F4		TEST RADIO NON OK	TEST RADIO NO OK
F5		ECHEC APPEL SORTANT	OUTGOING CALL FAILURE
F6		ECHEC APPEL ENTRANT	INCOMING CALL FAILURE
F7		PERTE TEMPORAIRE DE RESEAU	NETWORK TEMPORARY DROP
PROBLEME COSMETIQUE / DEFAUT VISUEL		COSMETIC PROBLEM	
G1		VITRE CASSEE OU ABIMEE	BROKEN OR DAMAGED GLASS
G2		COQUE CASSEE OU ABIMEE	BROKEN OR DAMAGED COVER
G3		FLAP CASSE OU ABIME	BROKEN OR DAMAGED FLIP
G5		CLAVIER CASSE OU ABIME	BROKEN OR DAMAGED KEYBOARD
G6		BOUTON VERROU DEFECTUEUX	DEFECTIVE LOCK BUTTON
AUTRES PROBLEMES		OTHER PROBLEM	
H1		KIT ACCESSOIRES HS	BROKEN OR DAMAGED ACCESSORY
H2		FONCTION FM (MOBILE)	FM FUNCTION (Mobile)
H3		FONCTION MONETIQUE	MONETIC FUNCTION
I1		TRACE D OXYDATION	OXYDATION MARKS
I3		PAS DE DEFAUT CONSTATE	NO FAULT FOUND
I5		MANQUE FONCTION DANS MENU	LACK FUNCTION IN THE MENU
I6		CONNECTEUR SIM DEFECTUEUX	DEFECTIVE SIM CONNECTOR
I7		DYSFONCTIONNEMENT D'UNE FONCTION DU MENU	MALFUNCTION OF THE MENU
I8		RECONFIGURATION DU MOBILE	MOBILE RETROFIT
PROBLEME MULTIMEDIA		MULTIMEDIA PROBLEM	
K1		PROBLEME DATA (SMS, EMS, SMS,GPRS, WAP, TELECHARGEMENT JEUX, SONNERIES, SAUVEUR D'ECRAN, NE COMMUNIQUE PAS AVEC UN PC, POCKET PC OU PALM)	DATA PROBLEM (SMS, EMS, SMS,GPRS, WAP, DOWNLOADING GAMES, RINGING TONES, SCREEN SAVER, NO COMMUNICATION WITH A PC, POCKET PC or PALM)
K2		FONCTION VIDEO	VIDEO FUNCTION
K3		FONCTION INFRAROUGE (IRDA)	INFRARED FUNCTION (IRDA)

		Ville / City :	
		Code postal / Poscode :	
		Pays/Country	
		Telephone / Phone :	
Nom du produit/product :		N° Série/Sérial n° :	
Date d'achat/Date of purchase		N° IMEI :	
Garantie/Warranty :		Hors garantie/Out of warranty :	
Garantie standard/Standard warranty : <input type="checkbox"/>		Garantie expirée /Expired warranty : <input type="checkbox"/>	
Déjà réparé/préviously repaired : <input type="checkbox"/>		Mauvaise utilisation / Missuse <input type="checkbox"/>	
Code SAGEM	Type de défaut	Kind of fault	
A0	AFFICHAGE DEFECTUEUX	DISPLAY MALFUNCTION	
A10	ANTENNE CASSEE / ABSENTE	ANTENNA BROKEN / MISSING	
B0	ALIMENTATION/CHARGE	POWER SUPPLY / NO CHARGE	
B7	PROBLEME D'AUTONOMIE	AUTONOMY	
B8	BATTERIE DEFECTUEUSE	BROKENBATTERY	
B11	CHARGEUR DEFECTUEUX	CHARGER MALFUNCTION	
C0	PROBLEME CLAVIER	KEYBOARD MALFUNCTION	
C2	PROBLEME TOUCHE LATERALE	LATERAL TOUCH PROBLEM	
D0	MESSAGE D'ERREUR	ERROR MESSAGE	
D1	SIM ABSENTE	SIM MISSING	
D7	CODE POSTE	POST CODE BLOCKED	
E0	PROBLEME AUDIO	AUDIO PROBLEM	
E3	MICRO DEFECTUEUX	MICROPHONE MALFUNCTION	
E5	PROBLEME DE VIBREUR	VIBRATING DEVICE MALFUNCTION	
F0	PROBLEME DE COMMUNICATION	COMMUNICATION MALFUNCTION	
G1	VITRE CASSEE OU ABIMEE	BROCKEN GLASS	
G2	COQUE CASSEE OU ABIMEE	BROCKEN COVER	
G3	FLAP CASSE OU ABIME	BROKEN FLIP	
G5	CLAVIER CASSE OU ABIME	BROCKEN KEYBOARD	
G6	BOUTON VERROU DEFECTUEUX	DEFECTIVE LOCK BUTTON	
K2	FONCTION VIDEO	VIDEO FUNCTION	
K3	FONCTION INFRAROUGE (IRDA)	INFRARED FUNCTION (IRDA)	
K4	FONCTION WAP	WAP FUNCTION	
K5	FONCTION GPRS	GPRS FUNCTION	
K6	FONCTION SMS, EMS, MMS.	SMS, EMS, MMS FUNCTION	
K7	NE COMMUNIQUE PAS AVEC UN PC	NO COMMUNICATION WITH A PC	
K8	NE COMMUNIQUE PAS AVEC UN POCKET PC OU PALM	NO COMMUNICATION WITH A POCKET PC or PALM	
K9	LIAISON DATA (MESSAGE "AUCUNE PORTEUSE DETECTEE")	DATA (MESSAGE "NO CARRIER DETECTED")	
K10	TELECHARGEMENT JEUX	DOWNLOADING GAME	
K11	TELECHARGEMENT IMAGE / SON / ECONOMISEUR D'ECRAN	DOWNLOADING PICTURE / RINGTONE / SCREEN SAVE	
H1	KIT ACCESSOIRES HS	BROCKEN ACCESSORIES	
H2	FONCTION FM (MOBILE)	FM FUNCTION	
H3	FONCTION MONETIQUE	MONETIC FUNCTION	
I5	MANQUE FONCTION DANS MENU	LACK FUNCTION IN THE MENU	
I7	DYSFONCTIONNEMENT D'UNE FONCTION DU MENU	MALFUNCTION OF THE MENU	
I8	RECONFIGURATION DU MOBILE	MOBILE RETROFIT	
I0	AUTRES DEFAUTS A PRECISER	OTHERS / TO BE PRECISED	

CHAPTER 6 - ACCESSORIES

4.80 12 V / 24 V CHARGERS

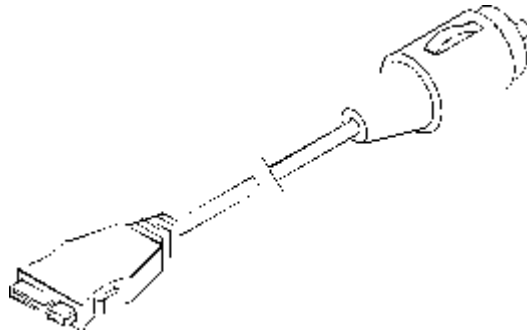

4.80.1 Description

This charger is for use in a car (or truck) only. The adapter is fitted with a cigar lighter type connector. AC1 is used to charge a mobile on a cigar lighter connector.

4.80.2 Characteristics

Item	Packaging reference	Input voltage	No load voltage	Output current	Comments
CIGAR LIGHTER CHARGER AC1	Blister	10.8 to 30 V=	6.5 V	500 mA	

4.81 DESKTOP CHARGERS AND CRADLES

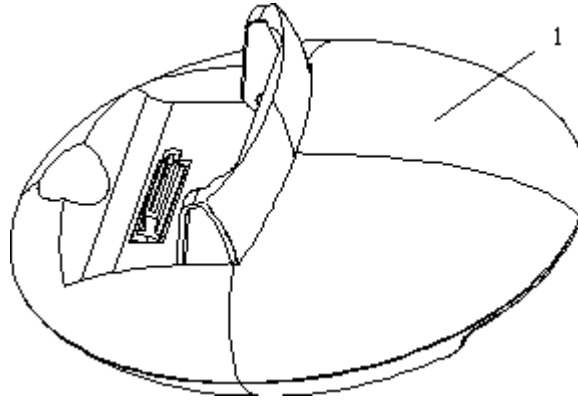

4.81.1 Description

This charger could charge a mobile, while acting as holder the handset.

4.81.2 Characteristics

Item	Designation	Nature
1	SIMPLE DESKTOP CRADLE	Simple support recess

4.82 CAR CRADLE

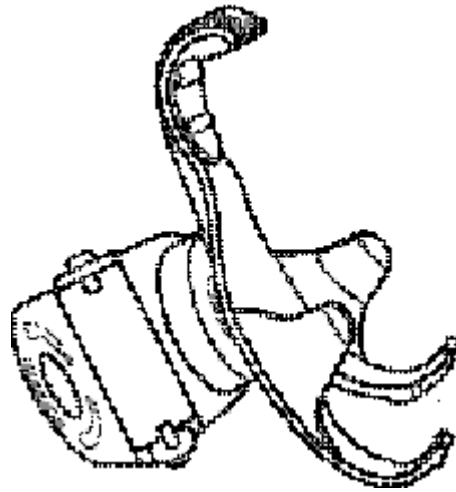

4.82.1 Description

Car cradle compatible with AC1 or antenna adapter.

4.82.2 Characteristics

Item	Packaging	Comments
CAR CRADLE KIT mechanical	BLISTER	Mechanical craddle

4.83 FULL DUPLEX CAR HANDSFREE KIT

6.4.1. Description

Rapido Kit : "compact" kit on cigar lighter,
 Kit K3 : "confort" kit for integration in car with phone equipment.

6.4.2. Characteristics

Item	Packaging	Comments
Rapido kit	Box	No antenna.

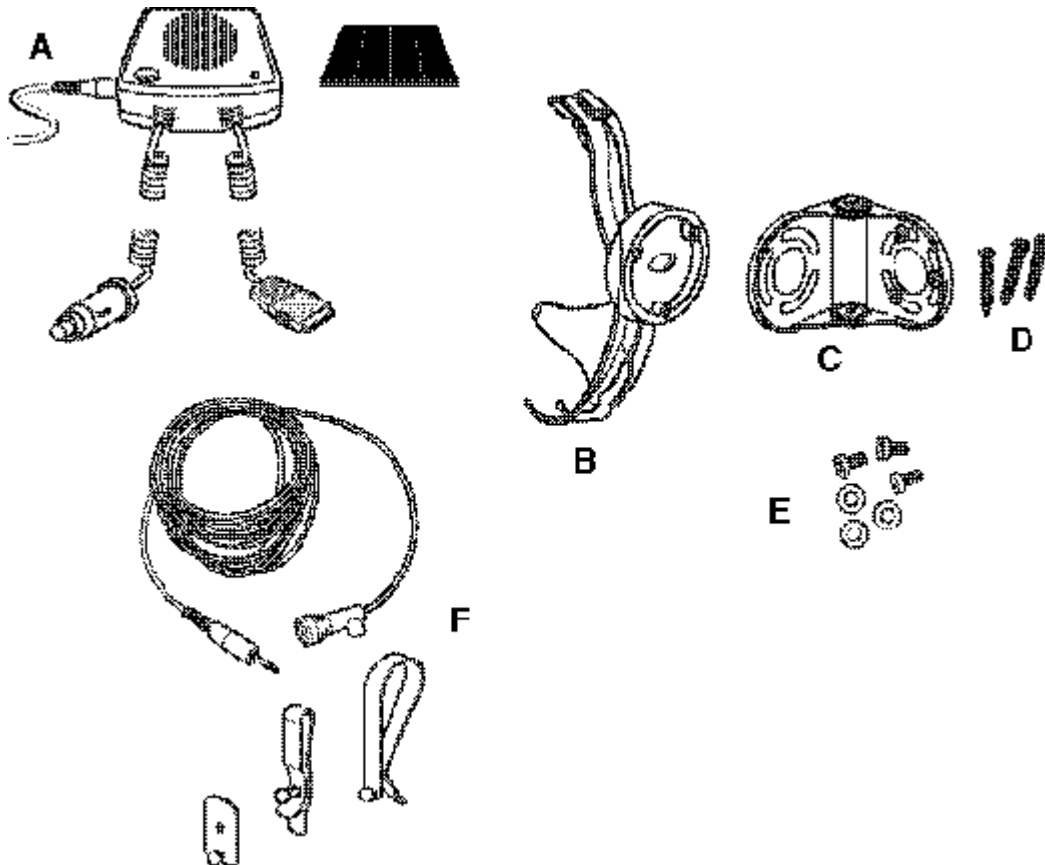

A : Connecting case and loudspeaker.

B : Cradle.

C, D et E : Support kit.

F : Microphone.

Item	Packaging	Comments
KIT K3	Box	No antenna. Requires car installation 900/1800 MHz dual band

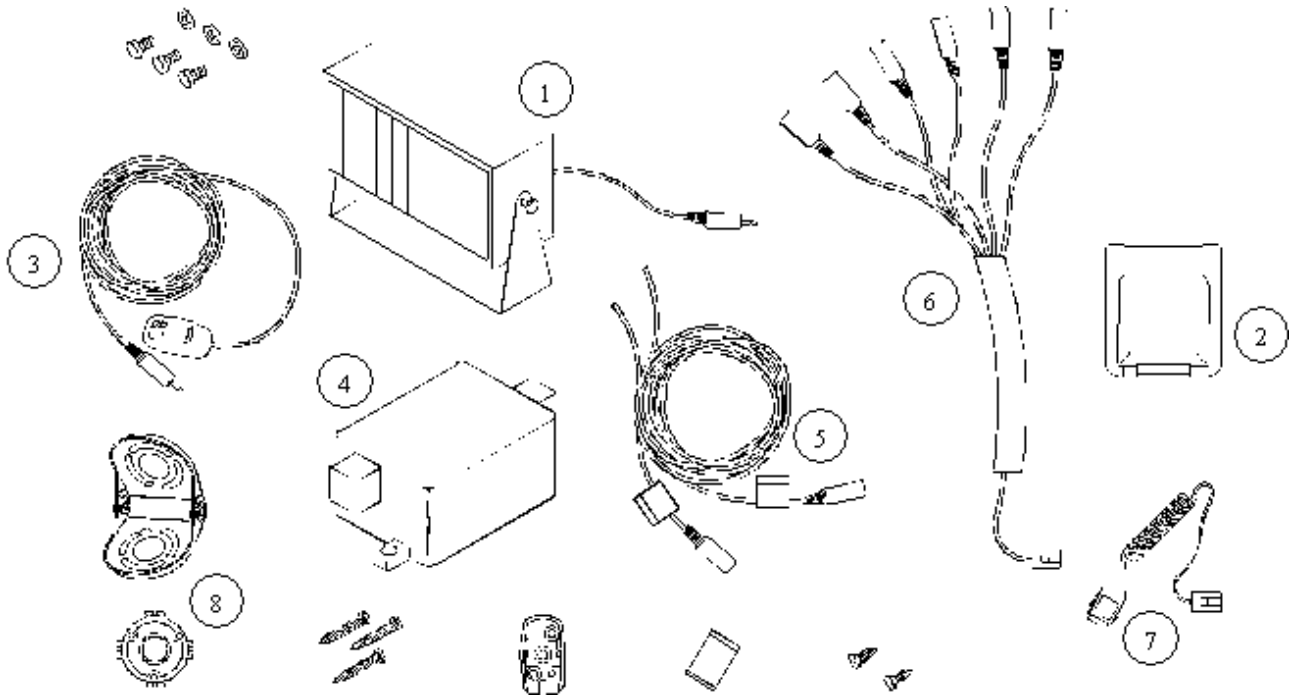

- 1 : Loudspeaker.
- 2 : Cradle.
- 3 : Microphone.
- 4 : Connecting case.
- 5 : Power supply cable.
- 6 : Cable : microphone, loudspeaker, car ⇔ connecting case.
- 7 : Cable : mobile ⇔ connecting case.
- 8 : Support kit.

4.5 PEDESTRIAN HANDSFREE KIT

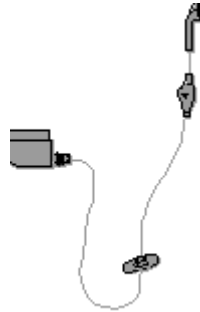

4.5.1 Description

Ear support with microphone on the cable for handsfree conversation.

4.5.2 Characteristics

Item	Dimensions	Loudspeaker impedance	Microphone
PEDESTRIAN HANDSFREE KIT	Length: 1.25 m Dist. micro/loudspeaker: 25 cm	150 Ω 119 dB SPL	2,2 kΩ -42 dB SPL

4.6 DATA CABLES

4.6.1 Description

Data cables are used for transferring data through standard equipment.

4.6.2 Characteristics

Item	Packaging	Target mobile	Mobile link to	Signals
DATA CABLE	Blister	Range 900/3000/myX- 3/myX-5	PC	Standard V28 3V<Us<-3V Fmax = 115kbauds

CHAPTER 7 - TECHNICAL INFORMATION BULLETIN

4.7 PURPOSE

The purpose of the Technical Information Bulletin (TIB) is to complete the maintenance operations described in this document. They give to the repair centers the complementary technical informations and the corrective procedures to be applied to maintain the product following it's evolution.

4.8 APPLICATION

The Technical Information Bulletin (TIB) are reference and must be applied by the repair centers.

The Technical Information Bulletin (TIB) will be sent only to the concerned repair centers. The Technical Data Bulletin will not be received by the repair centers with a reference number in sequence.

The follow up of the Technical Information Bulletin (TIB) and the action being to be performed are under the responsibility of the repair centers.

CHAPTER 5 - ILLUSTRATED PART CATALOG

8.1 myX-3 spare parts

ASSEMBLY	QTY	DESIGNATION
5	1	Glass
10	1	Front cover
15	1	Elastomer keyboard
20	1	Rear cover
25	1	Assembly plate
30	1	Metal dome
35	1	Light guide keypad
40	6	RLX 1,8-6 screw
45	1	Black & white display
50	1	Display support
55	1	Display clamp
60	1	Plate
65	1	Microphone
70	1	SIM locker
75	1	Vibrate
80	1	Battery connector
85	1	Loudspeaker with housing

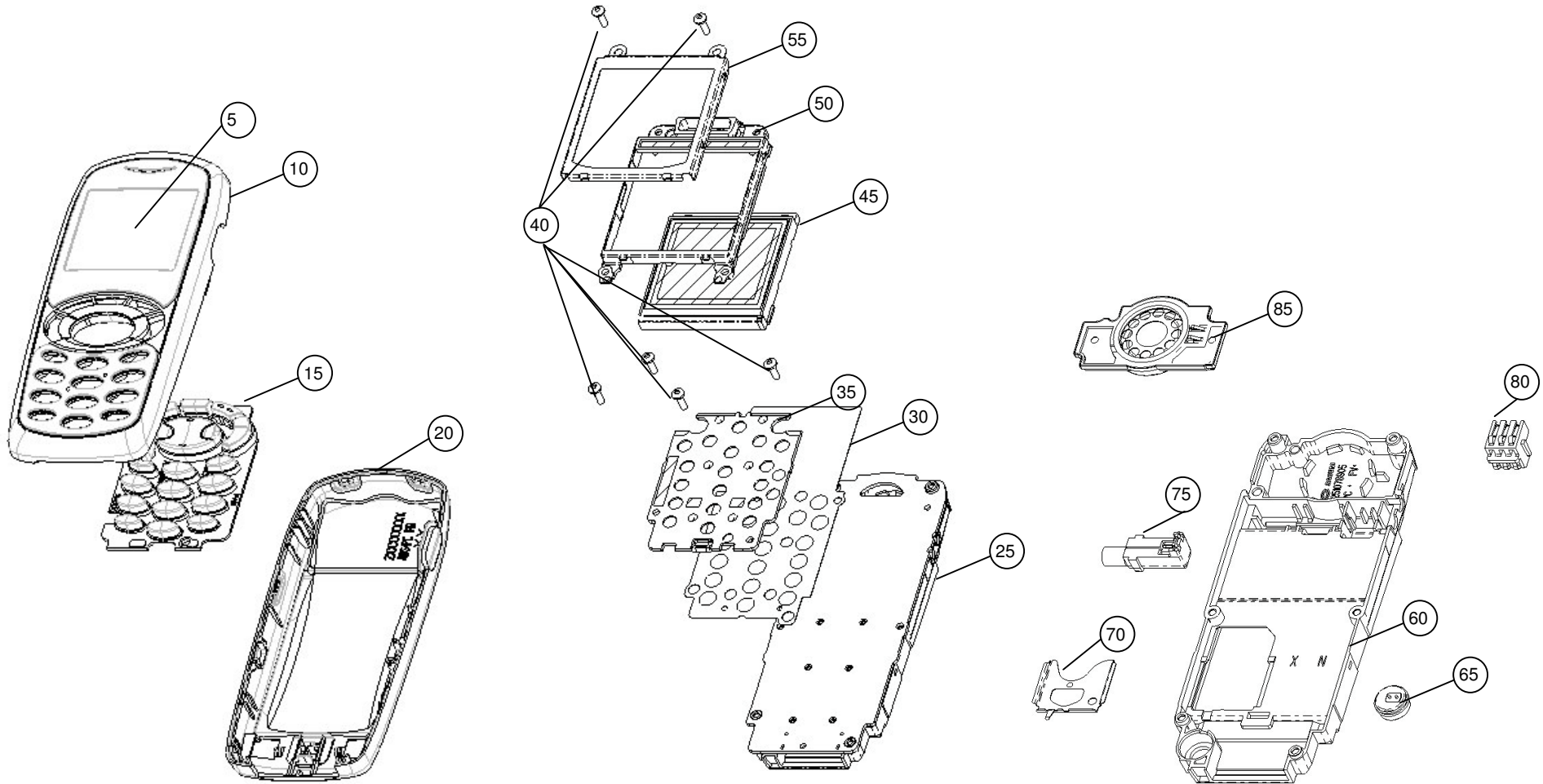

5.1 myX-5 spare parts

ASSEMBLY	QTY	DESIGNATION
5	1	Glass
10	1	Front cover
15	1	Elastomer keyboard
20	1	Rear cover
25	1	Assembly plate
30	1	Metal dome
35	1	Light guide keypad
40	6	RLX 1,8-6 screw
45	1	Colour display
50	1	Display support
55	1	Display clamp
60	1	Plate
65	1	Microphone
70	1	SIM locker
75	1	Vibrate
80	1	Battery connector
85	1	Loudspeaker with housing

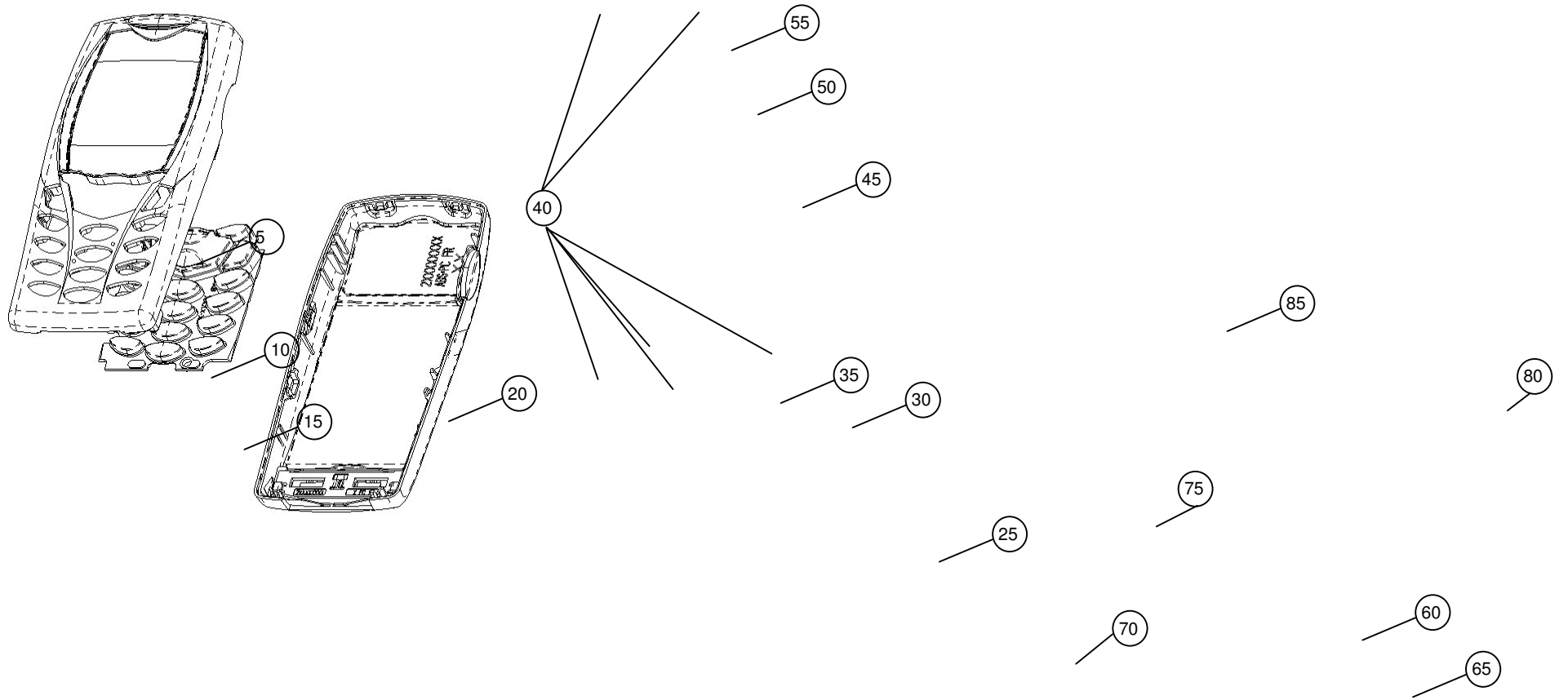

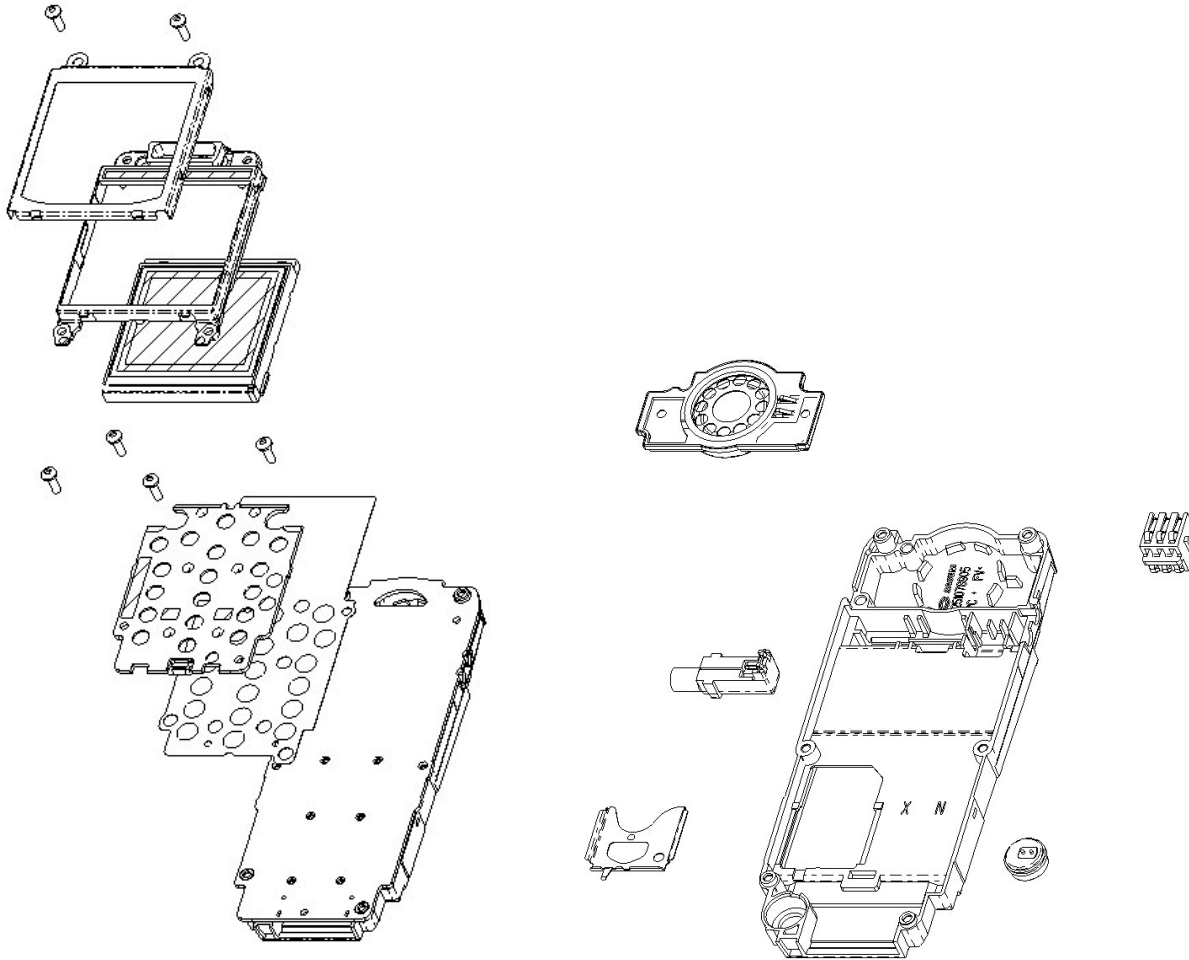

APPENDIX 1 - COMPOSITION TABLE

5.2 PURPOSE

This chapter contains the SAGEM codes of articles mentioned throughout the Site Technical Documentation.

5.3 LIST OF ARTICLES

BATTERIES	
Designation	Référence
Flat Li-Ion 720 mAh	18 778 323-2

4.5 V 400 mA MAINS MODULES	
Designation	Reference
Charger EC	18 678 723-6
Charger UK	18 678 741-8
Charger US	18 678 305-6
Charger AUS	18 678 572-7

TEST TOOLS	
Designation	Reference
Secured downloading kit	23 810 395-5
Mains charger test kit	23 810 480 - 8
myX-3 & myX-5 Metal dome jig	25 122 627-5
myX-3 & myX-5 radio interface	25 115 691-5
myX-5 ammeter interface	25 115 295-9
MyX-3 ammeter interface	Not defined

12 V / 24 V CHARGERS	
Designation	Reference
Cigar-lighter charger AC1	23 810 045 - 9

DESKTOP CHARGERS	
Designation	Reference
Desktop charger	23 812 376 - 7

FULL DUPLEX CAR HANDSFREE KIT	
Designation	Reference
Kit K3	23 811 416 - 4
Rapido Kit	23 811 861 - 7
Simple car support	23 812 339 - 5

PEDESTRIAN HANDSFREE KIT	
Designation	Reference
Pedestrian handsfree kit	23 810 082 - 1